

OPERATION and MAINTENANCE

10-K VARIABLE SPEED DRIVE LATHE

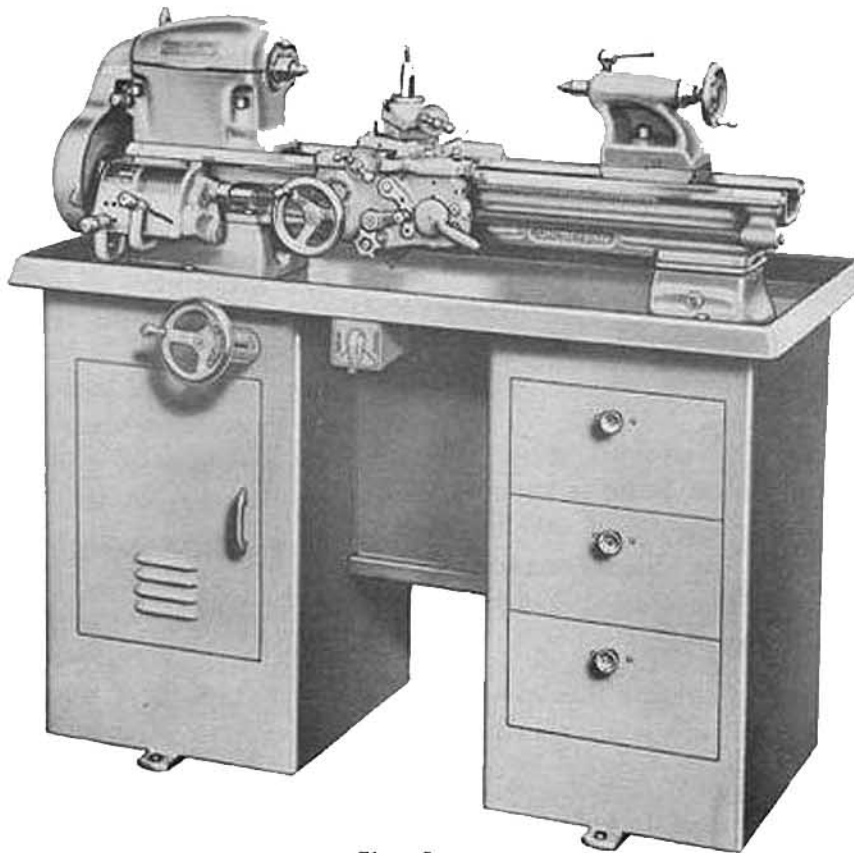

Fig. 1

This new infinitely variable speed drive makes it possible to change spindle speed by simply turning the speed dial while the machine is running. Necessary spindle speeds are immediately available for the various turning, boring, and finishing operations to be performed. An infinite number of spindle speeds are available between 325 to 1800 r.p.m. in direct drive and 65 to 360 r.p.m. in back gear drive.

The motor and drive unit is fully enclosed in the metal cabinet under the headstock to give protection from dust, dirt, and chips.

This operation and maintenance bulletin is for users of the South Bend 10-K Variable Speed lathe to give them the benefit of factory developed recommendations for getting the best work and longest possible trouble-free service from their machines.

This operation and maintenance bulletin should be used in conjunction with the "How to Run a Lathe" book, the current catalog "South Bend Machine Tools" for selecting tools to be used with the lathe, and service parts pages to identify accessories and replacement parts.

SOUTH BEND LATHE

South Bend, Indiana, U.S.A. 46623



..... Amsted
INDUSTRIES

SPECIFICATIONS

Swing over bed	10"	Collet capacity	5/8"
Swing over cross slide	6 1/4"	Spindle centers	No. 2 Morse taper
Spindle speed (approximate) ..	65 to 1800 r.p.m.	Small face plate diameter	5 1/8"
Thread cutting range, 48 pitches	4 to 224	Tool post take	3/8" x 13/16" tool holder
Power cross-feeds, 480004" to .0255"	Tailstock spindle travel	2 1/8"
Cross slide travel	5 7/8 tool room 5 5/8"	Tailstock set over	5/8"
Hole through spindle	27/32"	Size of motor	3/4 H.P.

OPERATION

1. Be sure the headstock cone cover and end gear guard is closed. Shift the belt release lever in back position. The belt release lever is located in the upper left side of the headstock cabinet leg.

2. Turn on lathe.

3. Turn speed dial to the desired speed. **Do not turn the speed dial unless lathe is running.** Changing speed when machine is off will force the unit out of adjustment. The speed ranges are from 325 to 1800 r.p.m. in direct drive and 65 to 360 r.p.m. in back gear drive.

4. It is recommended to operate the variable speed drive through its full range of speeds at least once daily.

For best belt life, do not start up lathe from its highest speed. To avoid this, simply turn dial down a little after finishing on high speed just before shut-down.

NOTE: An automatic safety interlock makes it impossible to open the end gear guard or headstock cover until the belt tension lever is placed in release (forward) position.

LUBRICATION

The variable speed drive pulley should be lubricated every 200 hours of operation. Use a good grade of ball bearing grease. Grease only a few shots, for both ends of this pulley shaft have grease seals. Over greasing may blow out the seals. Any excess grease getting on the pulleys will cause excessive belt slippage.

Periodically, oil the screw and slide bars of the variable speed drive unit.

For lubrication of other components of the variable speed lathe, see lubrication chart, No. 6514.

MAINTENANCE (Belts)

With normal wear it may be necessary to tighten the V-belts. To tighten: (a) Loosen motor mount screws, (b) Move motor down, (c) Retighten mount screws. Run lathe and recheck belts. Re-adjust if necessary.

To remove old V-belts just turn off pulleys by hand. When installing new belts loosen motor first and adjust belts as outlined above.

It is important that all pulleys as shafts be in proper alignment. A quick check is to (a) Set the drive at the middle of its speed range, (b) At this setting the movable pulleys should be operating in the middle of their shaft, (c) Using a straight edge against the motor pulley and the driven pulley, check to make sure that the belts are running straight from the pulleys. When the drive is properly aligned, the adjustable pulleys should occasionally bump the retaining washers at the extreme settings but not continuously rub either of the washers.

The unit has been aligned at the factory but should be rechecked any time the motor is moved.

To remove old flat belts, just cut off.

When installing new flat belt, these following steps may be taken to allow enough belt slack to fasten clamps for gluing. See parts page form 1935. (a) Remove cotter pin, washers, and pin (Items 34, 78, 61) from the end of turn buckle (Item 39) (b) Pull cradle assembly as far forward as possible and block to hold this position.

SPINDLE SPEEDS

We do not recommend changing the speed adjustment to exceed the high speed or decrease the low speed.

If the variable speed control is forced out of adjustment, it may be readjusted by following instructions outlined below. In these instructions the spindle speed may be checked by a tachometer or if tachometer is not available an approximate speed can be set by measuring dimensions "C" and "A" in Figure 2.

1. Crank the handwheel to high speed until the pulley opening at "A" is $1\frac{3}{8}$ " (See Fig. 2) or until spindle speed is 1800 r.p.m. in direct drive.

2. Loosen the set screw of stop collar "B" and slide against the variable control and retighten.

3. Crank the handwheel to low speed until the pulley opening at "C" is $1\frac{3}{8}$ " (See Fig. 2) or until spindle speed is 325 r.p.m. in direct drive.

4. Loosen the set screw of the stop collar "D" and slide the collar against the variable control and tighten.

5. To synchronize pointer on speed indicator with the drive unit (a) Loosen set screw "E", (See Fig. 3) (b) Hold bottom shaft steady and turn handwheel until pointer agrees with low speed limit, (c) Tighten set screw "E".

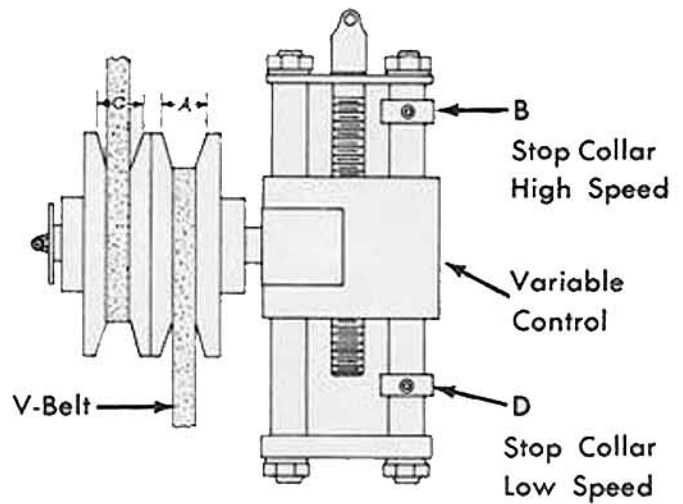

Fig. 2

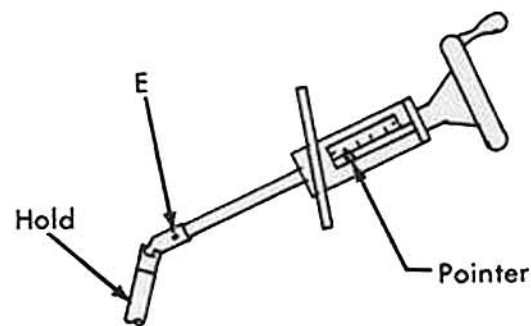

Fig. 3