

IMPORTANT

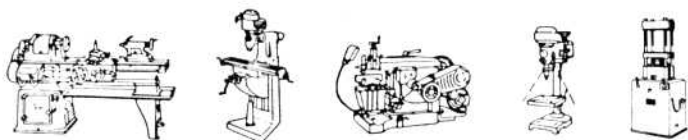

South Bend Machine Tools are designed and manufactured to assure you the greatest measure of long life performance. There remains, however the important factor of getting prompt service when replacement parts are required as a result of natural wear or accidental damage. This parts list was prepared for your convenience to determine quickly the part needed.

PARTS AND ASSEMBLIES. Frequently replacement parts are ordered that appear to be individual parts but in reality the particular part ordered is attached to other parts by press fit, hand scraping, tapered pins or by some other mechanical means which can only be properly done in our factory, and are part of an assembly. The part numbers with prefixes "*" and "AS" identify assemblies and the parts included in these assemblies are indicated by the item numbers appearing in parenthesis after the part name. Such parts are not sent out individually, but as assemblies.

SERIAL NUMBER, LATHE, VERT. MILL, SHAPER, MECH. PRESS, HYD. PRESS & MODEL NUMBER DRILL PRESS. This number must always appear on your order for replacement parts or attachments to assure prompt shipment of the part or attachment ordered. This number is an index as to the size, type and model of your machine, also date the machine was built. Location of these numbers illustrated at right.

CODE NUMBER. This number should also appear on your order of replacement part. This number is an index to the specific design of part that went into the unit assembly. We are continually making improvements on all South Bend Machine Tools. We may change the dimension or the appearance of a certain part, yet it is still interchangeable with the old part. You will always receive the benefit of the improved design on orders for replacement parts whenever interchangeability makes this possible. Location of this number (illustrated below) is shown on the repair parts sheet.

Therefore, when ordering we must have the following information:

1. Serial or Model No. of Machine.
2. Unit code number.
3. Part number & name of part required.
4. Quantity.

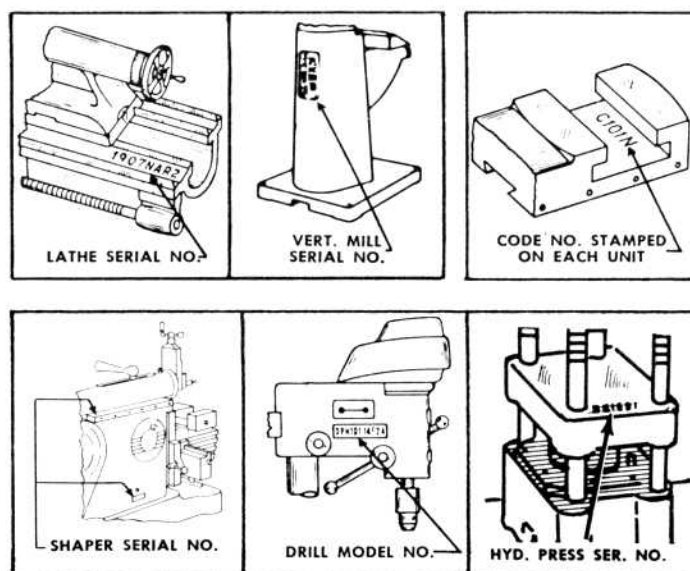

INDEX

SECTION 1

- 9" & 10K Lathes.
- 9" & 10K Toolroom Attachments.
- 9", 10K, 10" & 13" H.L. Bed Turrets.
- 9", 10K & 10" H.L. Double Tool Slides.

SECTION 2

- 10", 13", 14 1/2", 16" & 16-24" Lathes.
- 10", 13", 14 1/2", 16" & 16-24" Toolroom Attachments.
- 13" & 2H Turnstile Turrets.
- 13", 16" & 2H Double Tool Slides.
- Coolant Pump.

SECTION 3

- Lathe, Vertical Mill, Shaper, Drill Press & Pedestal Grinder Accessories.

SECTION 4

- Precision Drill Press
- Economy Drill Press

SECTION 5

- Shaper

SECTION 6

- Pedestal Grinder

SECTION 7

- Vertical Milling Machine
- 90° Milling Head

SECTION 8

- 17" Geared Head Lathe