

HOW TO USE THREAD DIAL

FOR ALL EVEN THREADS CLOSE LEAD SCREW HALF NUT ON ANY LINE ON THE DIAL. FOR ALL ODD THREADS CLOSE LEAD SCREW HALF NUT ON ANY NUMBERED LINE.

FOR ALL THREADS INVOLVING $\frac{1}{2}$ THREAD, SUCH AS $1\frac{1}{2}$, CLOSE LEAD SCREW HALF NUT ON ANY $\frac{1}{2}$ REVOLUTION OF THE DIAL.

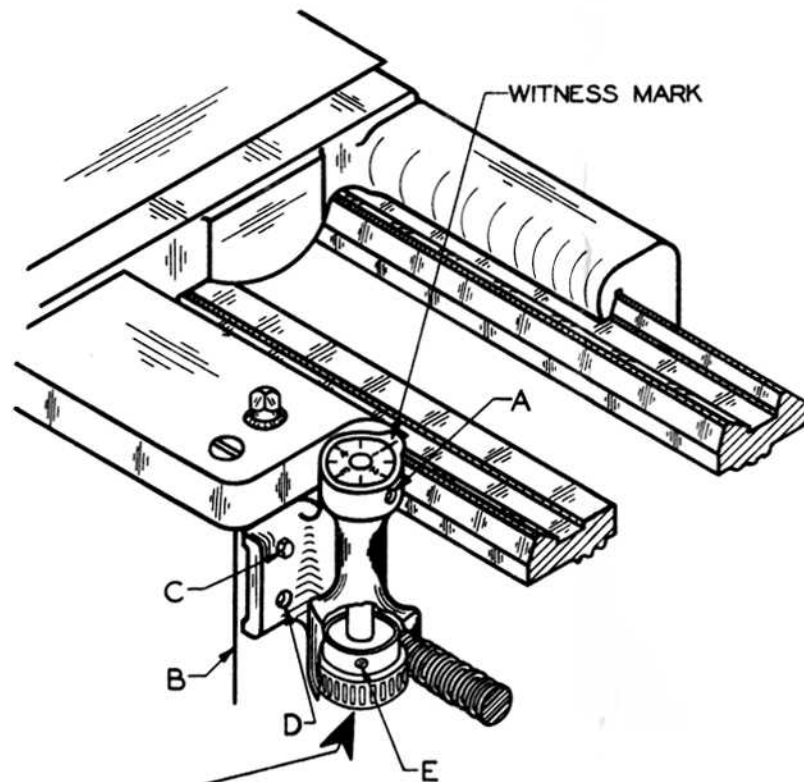

FOR 13" LATHE INVERT THIS GEAR

HOW TO ADJUST DIAL MARKS TO COINCIDE WITH WITNESS MARK

INSERT HEX. WRENCH IN HOLE "A" AND LOOSEN SET SCREW ENOUGH TO ALLOW THE SHAFT TO TURN. LEAVE THE HEX. WRENCH IN THE SLOT TO PREVENT DIAL FROM TURNING DURING THE NEXT OPERATION.

MESH THE THREAD DIAL WITH THE LEAD SCREW. CLOSE THE LEAD SCREW HALF NUT AND RUN THE LATHE UNTIL THE CARRIAGE TRAVELS AN INCH OR TWO TOWARD THE HEADSTOCK.

WITNESS MARK AND DIAL MARK MUST COINCIDE, THEN TIGHTEN SET SCREW SECURELY AND REMOVE HEX. WRENCH.

HOW TO INSTALL THE THREAD DIAL ON OLDER MODEL LATHES

CLAMP THE LEAD SCREW HALF NUT OVER THE THREADS OF THE LEAD SCREW, THEN CLAMP OR HOLD THE THREAD DIAL FIRMLY AGAINST THE RIGHT HAND SIDE OF THE LATHE APRON, MARKED "B", BEING SURE THAT THE WORM GEAR MESHES PROPERLY WITH THE LEAD SCREW.

WITH A SCRIBER OR A PUNCH, MARK THROUGH HOLE "C" ON APRON. REMOVE THE THREAD DIAL, THEN DRILL AND TAP THE HOLE. REPLACE THE THREAD DIAL ON THE SIDE OF THE APRON. MESH THE WORM GEAR WITH LEAD SCREW PROPERLY, THEN FASTEN IT SECURELY THROUGH THE HOLE JUST DRILLED AND TAPPED.

THE HOLE "D" IN THE THREAD DIAL FRAME IS LARGE ENOUGH TO CLEAR THE $\frac{3}{16}$ PIN, WHEN THE THREAD DIAL IS SWUNG OUT OF MESH. HOWEVER THE EDGE OF THE HOLE SHOULD REST AGAINST THE PIN WHEN THE THREAD DIAL IS IN OPERATION.

THE WORM GEAR SHOULD MESH WITH THE LEAD SCREW WITH NO BINDING AND NOT TOO MUCH BACK LASH.

NOTE :

FOR USE ON A 13" LATHE THE WORM GEAR ON THE THREAD DIAL INDICATOR MUST BE INVERTED. THEN TIGHTEN THE SET SCREW "E"

				UNIT.			
				10 TO 16" LATHE THREAD DIAL			
SHEET NO.				NO. SHEETS			
SCALE							
SOUTH BEND LATHE				SOUTH BEND, IND., U.S.A.			
3-15-47	A	NOTE ADDED	PEM.	DRAWN BY	C'KD. BY	TRACED BY	C'KD. BY
				MORGAN		MORGAN	J.W.
DATE	LET.	WAS	DR. NOTICE	1735	3-27-46	4-1-46	4-10-46