

MODEL NUMBER OF SHAPER AND UNIT CODE NUMBER MUST ACCOMPANY ORDER.

See List on Reverse Side

SOUTH BEND LATHE, INC. 425 E. Madison St., South Bend 22, Indiana, U.S.A.

Printed in U.S.A.

7" SHAPER TOOL SLIDE, VISE, AND CONTROL

ITEM	PART NO.	DESCRIPTION	PRICE EACH
1	CE2650NK	WRENCH	\$.85
1A	PT233NK1	TOOL POST SCREW	.90
2	PT5049S1	TOOL POST RING	1.00
3	PT250NK3	TOOL POST	4.30
4	PT5048S1	ORDER ITEM No. 7	...
5	PT5050S1	SWIVEL SCREW	.75
6	168x618	TAPER PIN	.15
7	*PA15047S2	CLAPPER BOX (4-6)	13.10
8	PT5054S1	LOCK SCREW	1.05
8A	161x17	WASHER	.05
9	*AS5012S1	TOOL SLIDE (16-17-19)	11.05
10	*AS5095S1	GRADUATED COLLAR (14-15)	1.25
11	PT295NR1	CRANK RETAINING NUT	.10
12	160x17	STRAIGHT PIN	.05
13	AS276R1	BALL CRANK	3.45
14	PT1076NR1	BINDER SHOE	.05
15	122x103	SET SCREW	.05
16	122x444	SET SCREW	.05
17	PT5052S1	LOCK SCREW	.75
18	PT5043S1	TOOL HEAD SCREW	3.10
19	PT5051S1	TOOL SLIDE GIB	.50
20	PT5045S1	CLAMP BOLT	1.20
21	PT5046S1	CLAMP SHOE	.50
22	PT5011S1	TOOL HEAD HOLDER	6.10
23	PT4965S1	PUSH BUTTON SWITCH	3.60
24	PT4995S1	PUSH BUTTON SWITCH	7.50
25	PT5112S1	TOOL TRAY	1.95
26	PT4076DP1	LAMP 115 V.	.21
27	PT5111S1	SWITCH BOX	4.75
27A	AS5111S1	SWITCH BOX ASSEMBLY (WHEN ORDERING THIS UNIT YOU MUST SPECIFY CODE NUM- BER STAMPED ON BOX.)	PRICE ON REQUEST
28	PT5113S1	SWITCH BOX COVER	2.10
29	*AS5119S2	WORK TABLE LIGHT (26)	11.50
30	PT4155S1	VICE JAW	1.05
31	PT4151S1	VICE JAW FRAME	6.10
32	114x20	CAP SCREW	.35
33	PT4154S1	VICE JAW GIB	.75
34	114x10	CAP SCREW	.30
35	155x16	BALL VALVE OILER	.20
36	PT4150S1	VICE BODY	12.40
37	PT4158S1	SCREW WASHER	.05
38	*AS4153S4	VICE JAW SCREW (37-41-42-56)	4.00
38A	PT4161S1	SCREW HANDLE	1.35
38B	PT406NT1	BAKELITE BALL	.70
39	160x17	PIN	.05
40	*AS5110S1	HOLD DOWN BOLT (39)	1.15
41	138x29	HEX JAM NUT	.10
42	PT4156S1	THRUST WASHER	.45
43	160x52	STRAIGHT PIN	.05
44	*AS4152S1	GRADUATED VISE BASE (43)	3.95
45	PT4160S1	KEY	.10
46	114x8	CAP SCREW	.30
47	161x30	FINISHED WASHER	.05
48	136x31	HEX. FULL NUT	.55
49	PT4063DP1	TOGGLE SWITCH	1.00
50	250x10	6 WIRE CABLE	1.10 FT.
51	AS4086DP1	THERMAL OVERLOAD RELAY AND BASE	11.10
52		POWER RELAY (SPECIFY POWER CHARACTERISTICS)	PRICE ON REQUEST
53	PT4085DP1	TRANSFORMER	11.00
54	PT4083S1	CONTROL BOX AND COVER	4.85
26A	PT4077DP1	LAMP-230 V.	.27
55	SE7300	ANGLE CONNECTOR	.45
56	160x25	PIN	.05

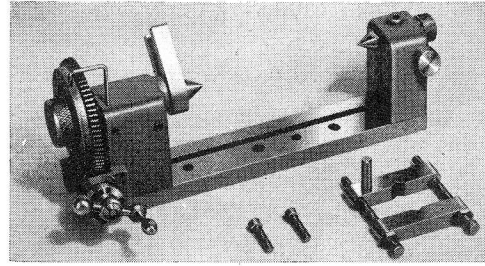

PATENT APPLIED FOR

Indexing Centers

This is an indispensable device for cutting splines or flutes in shafts, laying out work, accurate cross drilling, gear cutting, milling or shaping hexagons, squares, etc. Base has bolt holes for clamping on table of drill press, milling machine or shaper. Takes work between centers up to 5" in diameter, 5 3/16" long. Revolving center has large dial graduated 360°. Center is turned by worm gearing having graduated collar and ball crank. Each graduation indicates a center movement of 3 minutes. One complete revolution of the ball crank turns the center 5°. Worm gear can be disengaged for quick positioning of indexing center. Clamping device is provided for locking center in any position. Base has two bolt holes for clamping to machine table. Price includes two clamping bolts.

CE9635. Indexing Centers. PRICE \$69.75

Indexing Table

You will find this rotary indexing table a great convenience for mounting small work on the milling machine, drill press, or shaper. Used for accurately spacing bolt holes, indexing clutch teeth, machining square, hexagonal or octagonal shapes, milling circular grooves or T-slots, etc. Table is 4 1/2" in diameter and has three T-slots for clamping work. Edge of table is graduated 360°. Table is turned by worm gearing having graduated collar and ball crank. Each graduation indicates a table movement of 3 minutes. One complete revolution of the ball crank turns the table 5 degrees. Clamping device is provided for locking table in any position. Top of table is precision ground. Base has two bolt holes for clamping to machine table. Price includes eight clamping bolts with nuts and washers.

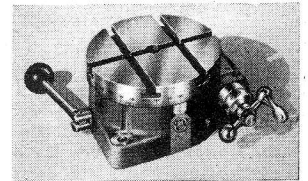

PATENT APPLIED FOR

CE9144. Indexing Table. PRICE \$56.00

Universal Table

Both upper and lower slides have graduated swivels and may be turned through full 360°. Slides can be used without graduated swivels to reduce height if desired. They can be positioned at any angle with each other and may be turned individually or together. Each slide has feed screw with micrometer collar reading in thousandths of an inch. Dovetails are equipped with full length gibs for take-up. The precision ground work surface is 4" x 8 7/8" and maximum travel is 4" for either slide. Table has four slots for clamping work. Clamp bolts fit snugly into round slots in such a way that there is little danger of breaking out or otherwise damaging the slots. Supplied with base for use on drill press, milling machines, etc., also with a specially designed base for mounting on the South Bend 7" Shaper. Slides and bases may be purchased separately if desired.

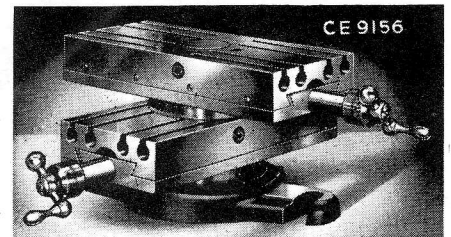

PATENT APPLIED FOR

CE9150. Universal Table complete with base for South Bend 7" Shaper, two slides, two graduated swivels, and eight clamp bolts with nuts. Shipping weight 37 lbs. PRICE \$107.00

Angle Plate

A heavy cast iron angle plate for clamping work on shaper, drill press, milling machine, face plate of lathe, etc. Size 4 1/2" x 3" x 2".

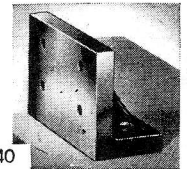

CE9640. Ship wt. 4 lbs. PRICE \$11.40

PRICES ARE F.O.B. SOUTH BEND, INDIANA. (SUBJECT TO CHANGE WITHOUT NOTICE)

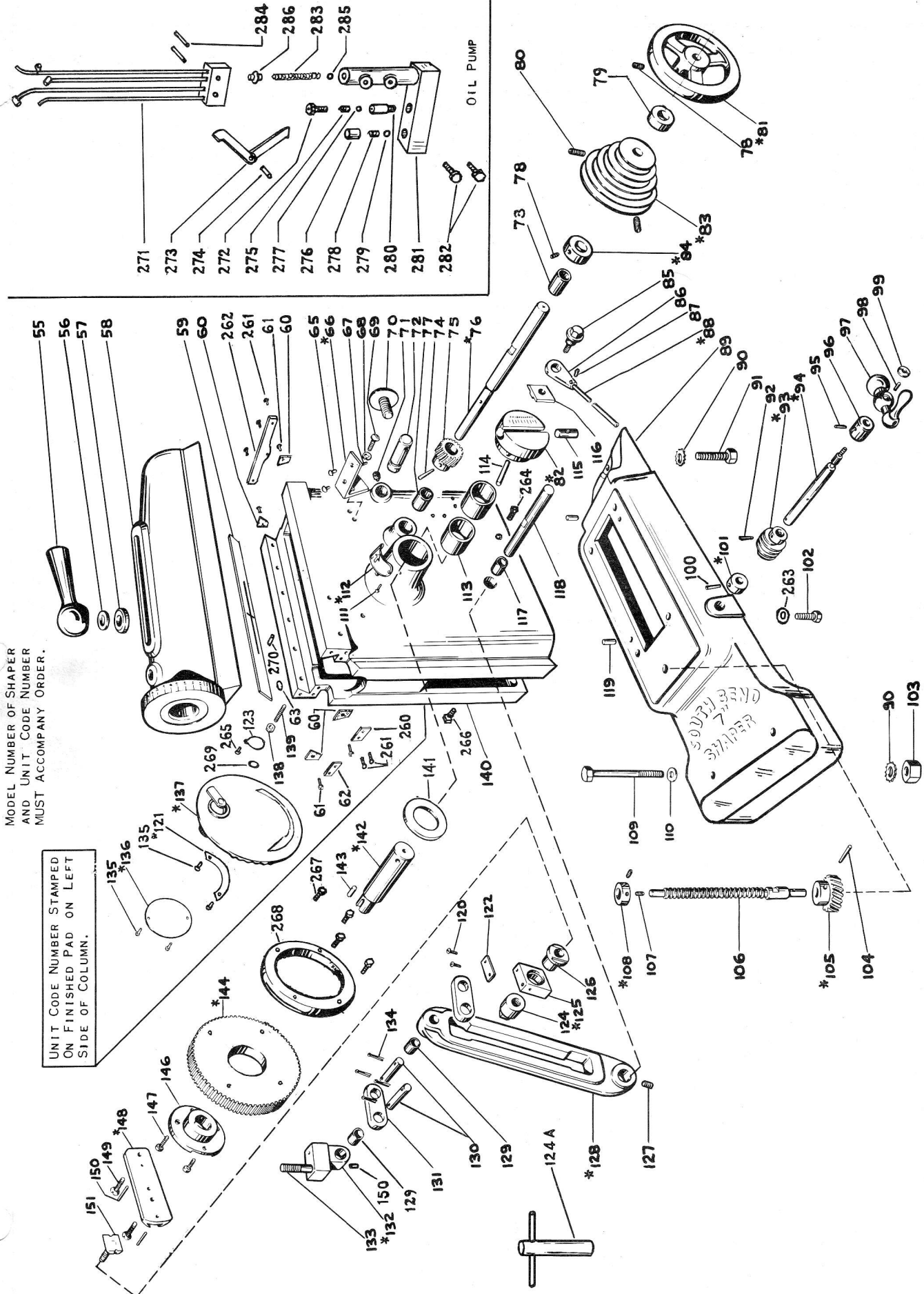

MODEL NUMBER OF SHAPER AND UNIT CODE NUMBER MUST ACCOMPANY ORDER.

UNIT CODE NUMBER STAMPED ON FINISHED PAD ON LEFT SIDE OF COLUMN.

See List on Reverse Side

7" SHAPER RAM, COLUMN, AND BASE

ITEM	PART NO.	DESCRIPTION	PRICE EACH	ITEM	PART NO.	DESCRIPTION	PRICE EACH
55	PT5019S1	RAM BLOCK HANDLE	\$ 3.60	125	*AS5042S1	ROCKER ARM SHOE (120-122)	\$ 4.10
56	PT5109S1	SPRING WASHER	.40	126	PT5031S1	SHOE LOCK BUSHING	1.15
57	PT5018S1	RAM BLOCK WASHER	.40	127	118x108	SET SCREW	.15
58	PT5002S2	RAM	PRICE ON REQUEST	128	*AS5003S1	ROCKER ARM (127)	30.30
59	PT5007S3	RAM GIB	1.55	129	PT5030S1	RAM BLOCK BUSHING	.70
60	PT4892S1	CHIP SCRAPER	.70	130	PT5023S1	ROCKER ARM SHAFT (SHORT)	.90
61	132x1101	PHILLIPS SCREW	.05	131	PT5022S1	ROCKER ARM LINK	.90
62	PT4957S1	LEFT FRONT OIL DRAIN	.70	132	*AS5021S2	RAM BLOCK (129-133-150)	4.00
63	PT4898-1	PLUG	.30	133	PT5020S2	ORDER ITEM No. 132	...
64				134	170x310	COTTER PIN	.05
65	PT387NK1	RUBBER BUMPER	.05	135	130x103	DRIVE SCREW	.05
66	*AS5099S1	GUARD BRACKET (67-68-69)	1.15	136	*AS3303	INSIGNIA PLATE (135)	.60
67	160x20	STRAIGHT PIN	.05	137	PA5004S2	COVER PLATE (135-136-121)	7.75
68	180x300	LOCK WASHER	.05	138	138x18	HEX NUT	.05
69	101x608	ROUND HEAD SCREW	.05	139	PT2980-1	SET SCREW	.40
70	PT4991S1	CAM	1.40	140	PT5001S7	COLUMN	PRICE ON REQUEST
71	121x104	SET SCREW	.15	141	PT4895S1	BULL GEAR SPACER	.85
72	PT5092S1	PIVOT STUD	1.15	142	*AS5013S1	BULL GEAR SHANK (143)	2.05
73	PT5028S2	DRIVE SHAFT BUSHING(LONG)	1.60	143	160x74	PIN	.05
74	168x107	TAPER PIN	.05	144	PT5006S5	BULL GEAR	19.90
75	PT5034S1	PINION GEAR	2.85	145			
76	*PA5009S2	DRIVE SHAFT (74-75)	8.90	146	PT5008S2	BULL GEAR HUB	4.75
77	PT5029S1	DRIVE SHAFT BUSHING (SHORT)	1.25	147	114x12	CAP SCREW	.30
78	120x108	SET SCREW	.20	148	*AS5014S1	STROKE ADJ. PLATE (149-150-151)	6.80
79	PT4963S1	COLLAR	.70	149	103x614	MACHINE SCREW	.05
80	120x8	SET SCREW	.20	150	160x19	STRAIGHT PIN	.05
81	*AS5005S1	HAND WHEEL (78)	7.90	151	PT5038S1	STROKE ADJ. STUD	1.60
82	*AS5078S2	TABLE FEED ECCENTRIC (114)	4.20	260	PT4956S1	RIGHT FRONT OIL DRAIN	.75
83	*AS5010S1	PULLEY (80)	7.25	261	144x1204	SCREW	.05
84	*AS5040S2	DRIVE PULLEY COLLAR (78)	.90	262	PT4958S1	REAR OIL DRAIN	1.20
85	PT5077S2	ECCENTRIC LOCK SCREW	.90	263	161x16	WASHER	.05
86	PT5075S1	ORDER ITEM No. 88	...	264	152x62	PIPE PLUG	.30
87	160x19	PIN	.05	265	101x306	SCREW	.05
88	*AS5079S1	FEED ROD (86-87)	3.30	266	PT1511-1	PIPE PLUG	.30
89	PT5000S4	BASE	60.00	267	114x12	CAP SCREW	.30
90	182x304	LOCK WASHER	.05	268	PT4961S1	OIL PUMP CAM	2.85
91	112x424	HEX BOLT	.15	269	PT4946-1	PLUG	.30
92	168x107	TAPER PIN	.05	270	PT4897S1	OIL TUBE CONNECTOR	.25
93	*AS5100S1	WORM (92)	2.55	271	AS4955S2	JUNCTION BOX ASSEMBLY	5.80
94	*AS5056S1	ELEVATING CRANK SHAFT (95-96-97-98-99)	6.45	272	PT4952S1	RELIEF VALVE STEM	.45
95	160x27	STRAIGHT PIN	.05	273	PT4960S2	OIL PUMP LEVER	1.00
96	PT5067S1	CRANKSHAFT COLLAR	.50	274	160x87	PIN	.05
97	AS276R1	C.F. BALL CRANK	3.45	275	162x55	SPRING	.20
98	160x17	PIN	.05	276	PT3090H1	OIL PUMP PLUNGER	1.55
99	PT295NR1	CRANK RETAINING NUT	.10	277	172x12	STEEL BALL	.05
100	168x107	TAPER PIN	.05	278	162x49	SPRING	.25
101	*AS5071S1	COLLAR(100)	.50	279	172x14	STEEL BALL	.05
102	112x214	CAP SCREW	.05	280	PT4951S1	RELIEF VALVE BODY	.75
103	138x31	HEX NUT	.10	281	PT4950S1	OIL PUMP	5.35
104	168x411	TAPER PIN	.10	282	103x208	SCREW	.05
105	*AS5101S1	WORM GEAR (104)	8.10	283	162x56	SPRING	.25
106	PT5057S1	ELEVATING SCREW	5.85	284	PT4894S1	FLOW ADJ. VALVE	.45
107	120x5	SET SCREW	.15	285	172x12	STEEL BALL	.05
108	*AS5066S1	ELEVATING SCREW COLLAR (107)	1.65	286	PT4953S1	FLANGED CONNECTOR	.70
109	112x460	HEX. BOLT	.30				
110	161x26	WASHER	.05				
111	130x103	METALLIC DRIVE SCREW	.05				
112	*AS5102S1	STROKE ADJ. PLATE (111)	.70				
113	PT5015S2	BULL GEAR SHANK BUSHING	1.50				
114	168x618	TAPER PIN	.15				
115	PT5041S1	ECCENTRIC LOCK SCREW NUT	.50				
116	PT5096S1	TABLE FEED POINTER	1.55				
117	PT5024S1	ROCKER ARM SHAFT BUSHING	1.25				
118	PT5037S1	ROCKER ARM SHAFT (LONG)	1.00				
119	153x2	LOCATING PINS	.30				
120	101x6	MACH. SCREW	.05				
121	*AS4890S1	OIL SPEC. CHART (135)	1.45				
122	PT4893S1	ROCKER ARM SHOE OIL TRAY	.65				
123	PT2531RT1	OIL HOLE COVER	.25				
124	PT5036S1	STROKE ADJ. STUD NUT	1.55				
124A	CE2750	TEE WRENCH	2.15				

PRICES ARE F.O.B. SOUTH BEND, INDIANA. (SUBJECT TO CHANGE WITHOUT NOTICE)

SOUTH BEND LATHE, INC. 425 E. Madison St., South Bend 22, Indiana, U.S.A.

Printed in U.S.A.

MODEL NUMBER OF SHAPER
AND UNIT CODE NUMBER
MUST ACCOMPANY ORDER.

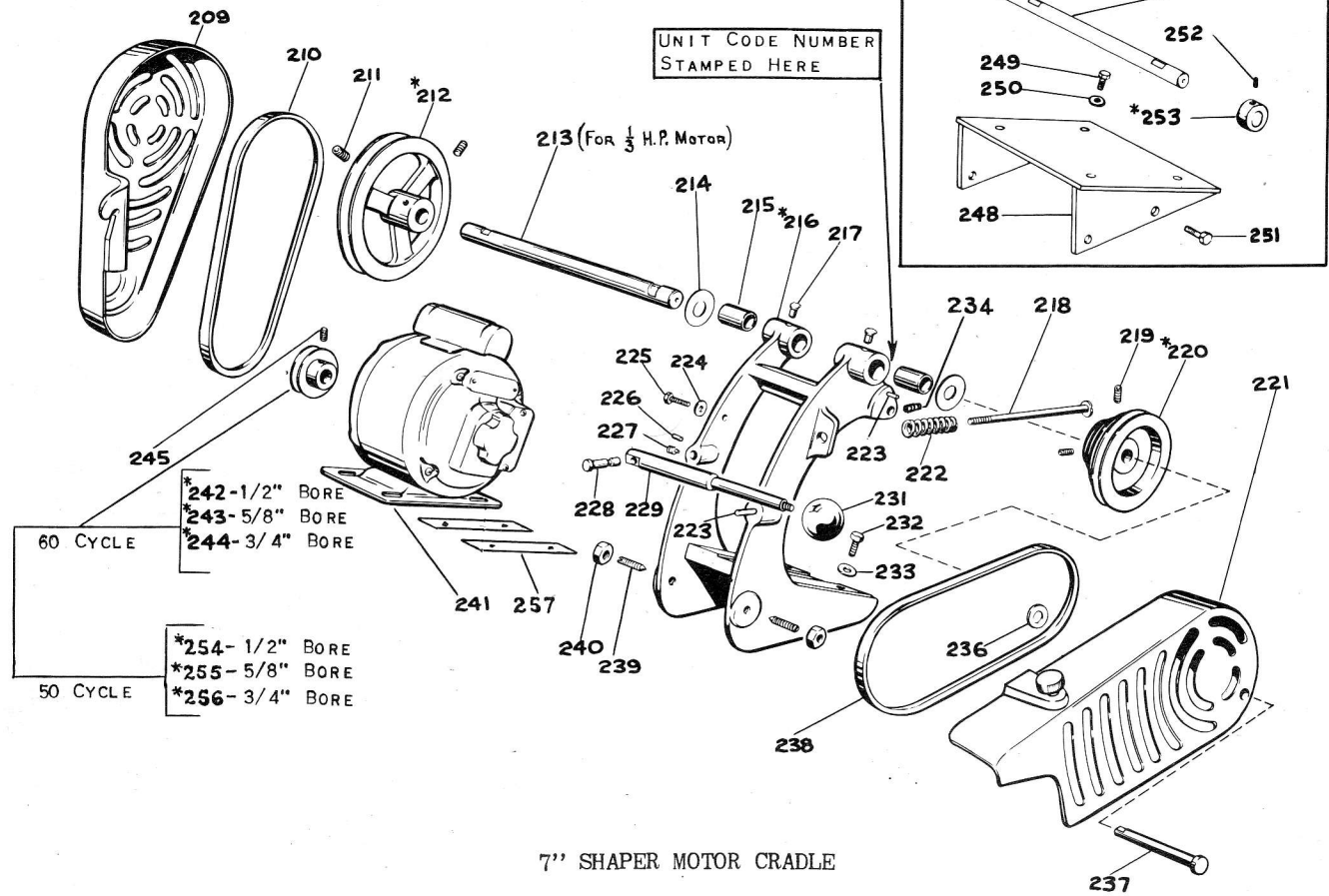

7" SHAPER MOTOR CRADLE

ITEM	PART NO.	DESCRIPTION	PRICE EACH	ITEM	PART NO.	DESCRIPTION	PRICE EACH
209	PT5087S1	MOTOR PULLEY GUARD	\$ 11.50	235
210	CE4L 280	'V' BELT	1.26	236	PT4985S1	WASHER	\$.05
211	120x106	SET SCREW	.20	237	PT5098S3	GUARD STUD	1.00
212	*AS5088S1	COUNTERSHAFT PULLEY (211)	7.55	238	CE4L 290	'V' BELT	1.28
213	PT5089S2	COUNTERSHAFT, 1/3 H.P.	2.30	239	PT704DP1	SET SCREW	.30
214	PT5108S1	COUNTERSHAFT WASHER	.05	240	138x27	HEX. NUT	.05
215	PT4997S1	BUSHING	1.25	241	SHAPER ELECTRIC MOTOR	PRICE ON REQUEST
216	*AS5086S3	MOTOR CRADLE (217-215-223-226)	41.90	242	*AS5400S1	MOTOR PULLEY (245)	2.10
217	155x20	GITS OILER	.25	243	*AS5401S1	MOTOR PULLEY (245)	2.10
218	PT4990S1	CRADLE TENSION BOLT	1.05	244	*AS5402S1	MOTOR PULLEY (245)	2.10
219	120x108	SET SCREW	.20	245	120x105	SET SCREW	.20
220	*AS5010S1	DRIVE PULLEY (219)	7.25	246	PT4983S2	COUNTERSHAFT, 1/2 H.P.	2.60
221	PA5097S2	DRIVE PULLEY GUARD	14.50	247	160x236	PIN	.05
222	PT4988S1	CRADLE TENSION SPRING	.40	248	PA4993S1	MOTOR BASE ADAPTER, 1/2 H.P.	18.50
223	160x90	STRAIGHT PIN	.05	249	112x108	CAP SCREW	.05
224	161x12	WASHER	.05	250	161x12	WASHER	.05
225	112x116	CAP SCREW	.05	251	112x110	CAP SCREW	.05
226	PT1803	STRAIGHT PIN	.05	252	120x5	SCREW	.15
227	120x5	SET SCREW	.15	253	*AS4982S1	COLLAR (252)	.95
228	PT4987S1	PIN	.45	254	*AS4979S1	MOTOR PULLEY (245)	2.50
229	PT4989S2	CRADLE ADJUSTING LEVER	1.55	255	*AS4980S1	MOTOR PULLEY (245)	2.50
230	*AS4992S2	BRACKET (247)	3.65	256	*AS4981S1	MOTOR PULLEY (245)	2.50
231	PT406K&FH1	BAKELITE BALL	.70	257	PT4999S1	MOTOR SHIM	.50
232	112x112	CAP SCREW	.05				
233	161x12	WASHER	.05				
234	121x104	SET SCREW	.15				

PRICES ARE F.O.B. SOUTH BEND, INDIANA. (SUBJECT TO CHANGE WITHOUT NOTICE)

SOUTH BEND LATHE, INC. 425 E. Madison St., South Bend 22, Indiana, U.S.A.

Printed in U.S.A.

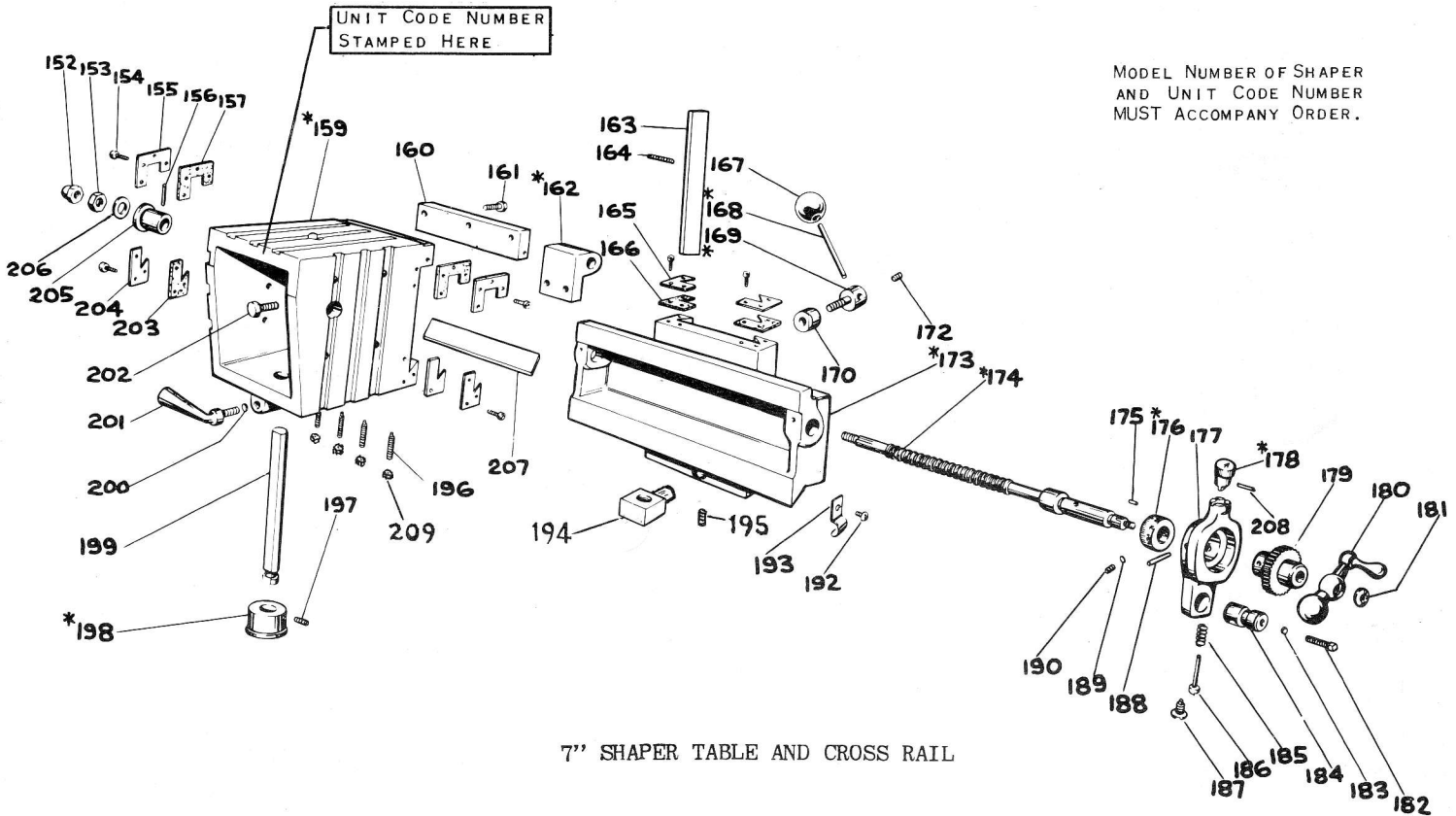

7" SHAPER TABLE AND CROSS RAIL

ITEM	PART NO.	DESCRIPTION	PRICE EACH	ITEM	PART NO.	DESCRIPTION	PRICE EACH
152	PT4066DP1	ACORN NUT	\$.40	183	PT1082FH1	BRASS SHOE	\$.05
153	139x27	HEX. JAM NUT	.05	184	PT5074S1	ROCKER ARM PIVOT	.75
154	132x1103	PHILLIPS SCREW	.05	185	PT5105S1	FEED PAWL SPRING	.25
155	PT4966S1	Sq. C.R. FELT RETAINER	.25	186	PT5080S1	FEED PAWL	.45
156	160x16	STRAIGHT PIN	.05	187	PT4998S1	ROCKER ARM PIVOT SCREW	.25
157	PT4967S1	Sq. C.R. FELT WIPER	.30	188	PT1809	STRAIGHT PIN	.10
158				189	PT1076NR1	SHOE	.05
159	*AS5085S1	TABLE (154-155-157-160-161-196-203-204-207-209)	50.30	190	122x102	SET SCREW	.05
160	PT5070S1	TOP GUIDE GIB	2.00	191
161	111x14	CAP SCREW	.20	192	101x304	MACHINE SCREW	.15
162	*AS5058S2	C. F. SCREW NUT (202)	3.95	193	PT3096H1	OIL TUBE CLAMP	.50
163	PT5068S2	CROSS RAIL GIB	.90	194	PT5069S2	ELEVATING SCREW NUT	1.75
164	121x10 12	SET SCREW	.25	195	120x6	SET SCREW	.15
165	PT4968S1	COLUMN FELT RETAINER	.25	196	121x10 16	SET SCREW	.25
166	PT4969S1	COLUMN FELT WIPER	.10	197	PT4972S1	SET SCREW	.75
167	PT406NT1	BAKELITE BALL	.70	198	*AS5060S3	TABLE SUPPORT BRACKET(197)	2.40
168	*AS5064S1	CROSS RAIL LOCK HANDLE(167)	1.00	199	PT5059S2	TABLE SUPPORT SHANK	1.20
169	*AS5072S1	CROSS RAIL LOCK BOLT (172)	1.00	200	PT1084H1	BRASS SHOE	.10
170	PT5065S1	CROSS RAIL LOCK WEDGE	.50	201	PT5061S1	BINDING LEVER	.75
172	120x903	SET SCREW	.20	202	112x116	CAP SCREW	.05
173	*AS5084S3	CROSS RAIL (163-164-165-166)	39.65	203	PT4971S1	C.R. FELT WIPER	.30
174	*AS5055S3	CROSS FEED SCREW (175-176-177-178-179-180-181-185-186-187-188-189-190-208)	30.30	204	PT4970S1	C.R. FELT RETAINER	.25
175	160x17	STRAIGHT PIN	.05	205	PT5073S2	BUSHING C. F. THRUST	1.20
176	*AS5063S1	CROSS FEED GRAD. COLLAR (189-190)	1.45	206	PT5026S2	SPRING WASHER	.35
177	PT5082S2	FEED PAWL LEVER	4.45	207	PT5062S1	TABLE GIB	.65
178	*AS5083S1	PAWL LEVER KNOB(185-186-208)	1.60	208	160x260	STRAIGHT PIN	.05
179	PT5076S1	ROCKER ARM RATCHET WHEEL	2.65	209	138x18	NUT	.05
180	AS276R1	C.F. BALL CRANK	3.45				
181	PT295NR1	CRANK RETAINING NUT	.10				
182	118x16	SET SCREW	.15				

See Reverse Side

PRICES ARE F.O.B. SOUTH BEND, INDIANA. (SUBJECT TO CHANGE WITHOUT NOTICE)