

**9" & 10-K APRON
Model A & B**

Unit Code Number
Stamped Here

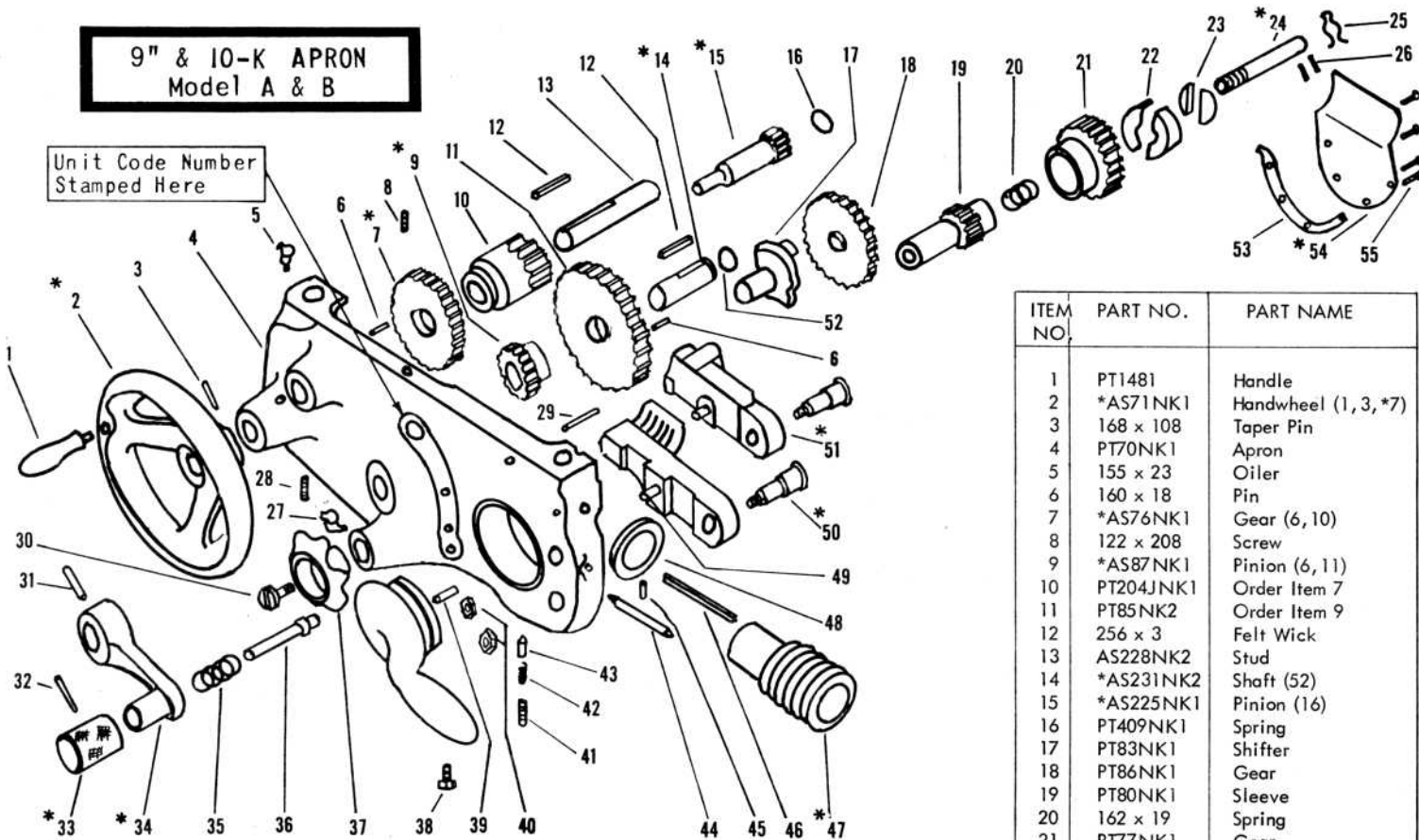

SERIAL NUMBER OF LATHE AND UNIT
CODE NUMBER **MUST** ACCOMPANY ORDER

Unit Code Number
Stamped Here

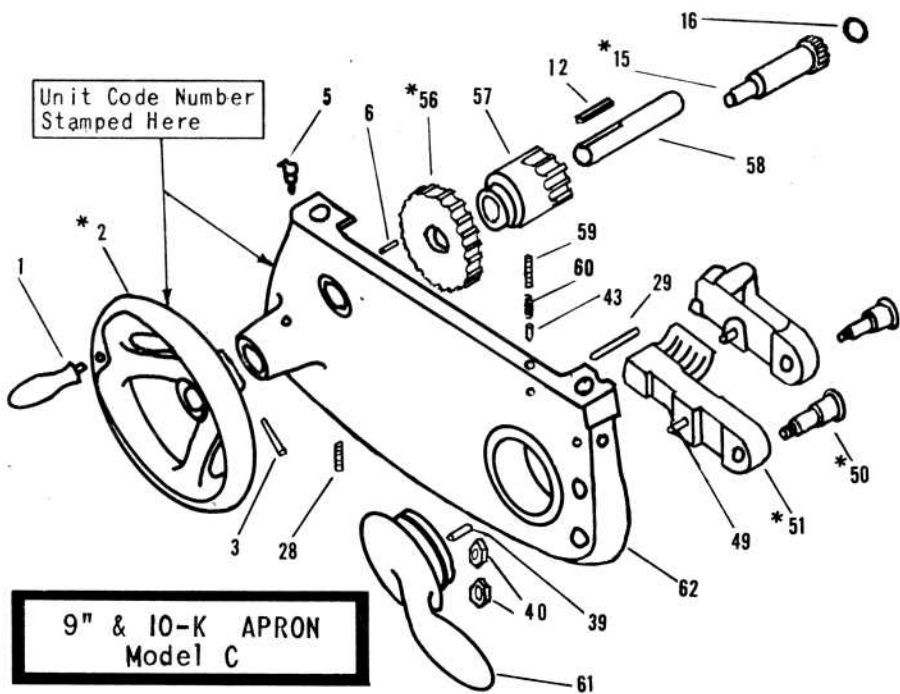

**9" & 10-K APRON
Model C**

* AVAILABLE ONLY AS SUB-
ASSEMBLY. PARTS INCLUDED
ARE INDICATED BY THE ITEM
NUMBERS APPEARING IN PAR-
ENTHESIS AFTER PART NAME.

ITEM NO	PART NO.	PART NAME
1	PT1481	Handle
2	*AS71NK1	Handwheel (1,3,*7)
3	168 x 108	Taper Pin
4	PT70NK1	Apron
5	155 x 23	Oiler
6	160 x 18	Pin
7	*AS76NK1	Gear (6,10)
8	122 x 208	Screw
9	*AS87NK1	Pinion (6,11)
10	PT204JNK1	Order Item 7
11	PT85NK2	Order Item 9
12	256 x 3	Felt Wick
13	AS228NK2	Stud
14	*AS231NK2	Shaft (52)
15	*AS225NK1	Pinion (16)
16	PT409NK1	Spring
17	PT83NK1	Shifter
18	PT86NK1	Gear
19	PT80NK1	Sleeve
20	162 x 19	Spring
21	PT77NK1	Gear
22	PT352NK1	Shoes (Pair)
23	PT353NK1	Expanders (Pair)
24	*AS223NK2	Screw (26,30)
25	PT349NK1	Spring
26	160 x 22	Pin
27	PT2677NR1	Oiler
28	120 x 108	Screw
29	PT2854NK1	Oil Tube
30	PT355NF1	Screw
31	168 x 210	Taper Pin
32	160 x 10	Pin
33	*AS88NK2	Knob (32,35,36)
34	*AS84NK1	Lever (17,31,*33)
35	162 x 35	Spring
36	PT89NK1	Order Item 33
37	PT82NK1	Knob
38	PT1511	Pipe Plug
39	160 x 76	Pin
40	137 x 25	Nut
41	122 x 604	Screw
42	162 x 5	Spring
43	PT351NK1	Pin
44	PT97NK2	Plunger
45	160 x 19	Pin
46	PT690NK1	Key
47	*AS203NK1	Worm (45,46,48)
48	PT208NK1	Collar
49	PT172NK1	Pin
50	*AS350NK1	Screw (40)
51	*AS72NK1	Half Nut (49)
52	PT357NK1	Spring
53	PT412NK1	Gasket
54	*AS227NK1	Trough (53,55)
55	101 x 104	Screw
56	*AS76JNK1	Gear (6,57)
57	PT204JNK1	Order Item 56
58	AS228JNK1	Stud
59	122 x 606	Screw
60	162 x 34	Spring
61	AS74JNK1	Cam
62	PT70JNK1	Apron

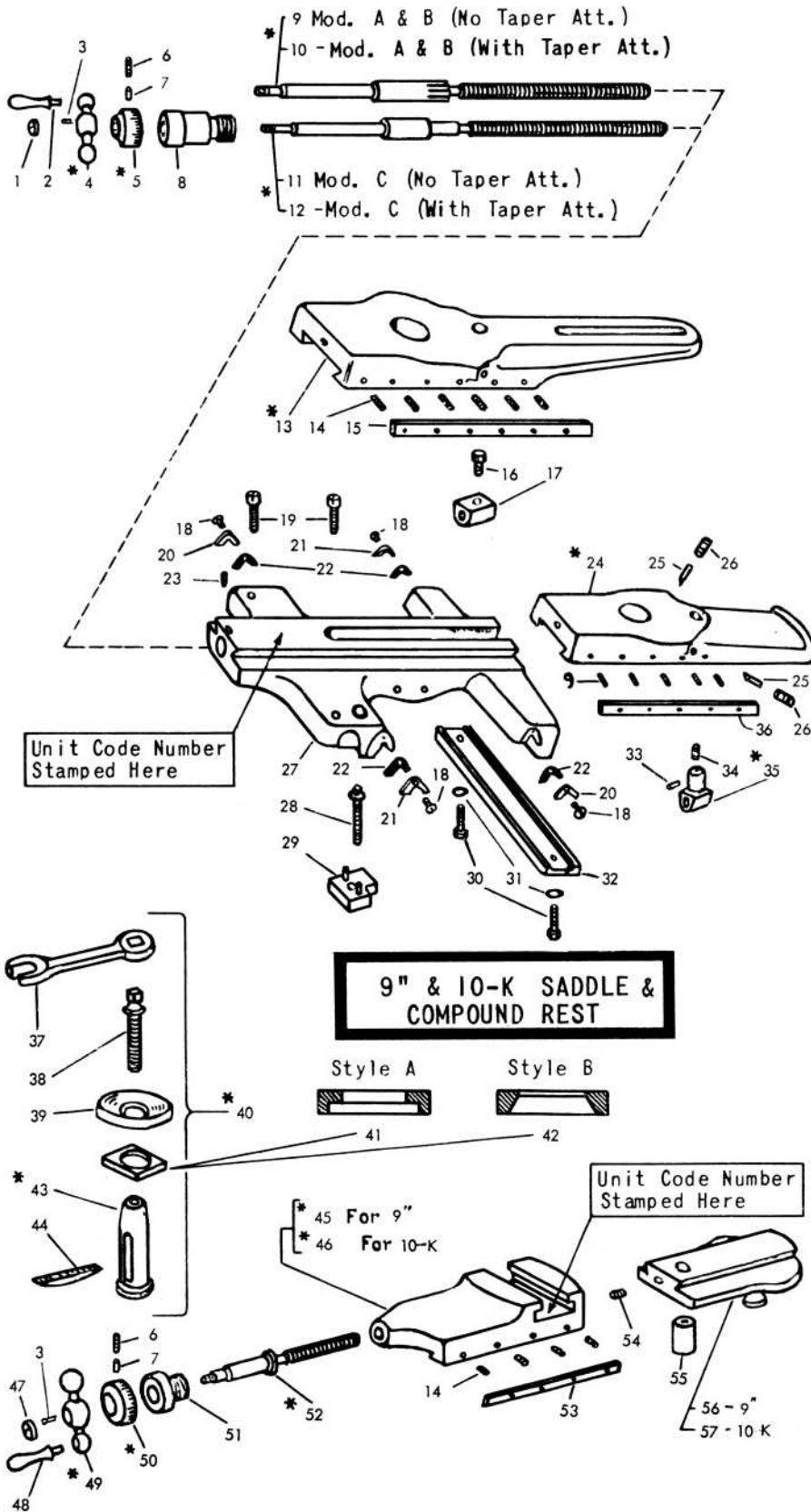

ITEM NO	PART NO.	PART NAME
1	PT295R1	Nut
2	PT1480	Handle
3	160 x 17	Straight Pin
4	*AS276NK1	Ball Crank (2)
5	*AS64NK1	Collar (6,7)
6	122 x 103	Screw
7	PT1076NR1	Binder Shoe
8	PT63NK1	Bushing
9	*AS224NK2	Cross Feed Scr. (1, *4, *5, 8, *35)
10	*ATA224NK2	T.A.C.F. Screw (1, *4, *5, 8, 16, 17)
11	*AS224JNK2	C. F. Screw (1, *4, *5, 8, *35)
12	*ATA224JNK2	T.A.C.F. Screw (1, *4, *5, 8, 16, 17)
13	*AS485NK1	T. A. Base (14, 15, 25, 26)
14	122 x 444	Screw
15	PT874NK1	Gib
16	PT66NK1	Screw
17	PT486NK1	Cr. Feed Nut
18	107 x 6	Screw
19	PT244NK1	Saddle Screw
20	PT58NK1	Retainer - R
21	PT57NK1	Retainer - L
22	PT59NK1	Felt Wiper
23	122 x 102	Screw
24	*AS92NK2	Base (14, 25, 26, 36)
25	PT211NK1	Shoe
26	121 x 212	Screw
27	AS60NK2	Saddle
28	PT210NK2	Lock Screw
29	AS62NK2	Lock
30	112 x 114	Screw
31	PT3400	Washer
32	PT61NK1	Gib
33	PT358NK1	Pin
34	PT359NK1	Lock Screw
35	*A665NK1	C.F. Nut (33, 34)
36	PT221NK1	Gib
37	CE2650NK	Wrench
38	PT233NK1	T. P. Screw
39	PT251NK1	Ring
40	*CE2450NK	Tool Post Ass'y.
41	PT209NK1	Block
42	PT209NK2	Block
43	*AS250NK3	Tool Post (41 or 40)
44	PT252NK2	Wedge
45	*AS90N1	C.R. Top (*52, 14, 53, 56)
46	*AS90K1	C.R. Top (*52, 14, 53, 57)
47	PT295NR1	Nut
48	PT1480	Handle
49	*AS277NR1	Crank (48)
50	*AS110NK1	Collar (6,7)
51	PT94NK1	Bushing
52	*AS230NK2	Screw (37, *49, 50, 51, 55)
53	PT257NK1	Gib
54	122 x 508	Screw
55	PT95NK1	C.R. Nut
56	PT91N1	Swivel
57	PT91K1	Swivel

*Available only as sub-assembly. Parts included are indicated by the item numbers appearing in parenthesis after part name.

Prices Net. F.O.B. South Bend, Ind. (Subject to change without notice)