

Oiling Chart

for South Bend Underneath Belt Motor Drive Lathes

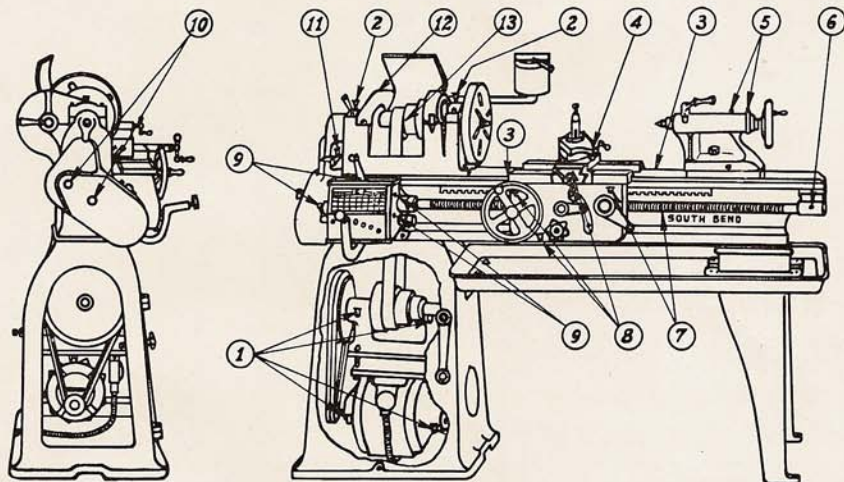

- | | |
|---|---|
| 1—Countershaft Bearings..... | Fill with oil once a week. |
| 2—Headstock Spindle Bearings..... | Fill oil cups every hour the first 100 hours, twice a day thereafter. |
| 3—Carriage "V" Ways and Dovetails.. | Keep well oiled and wipe frequently. |
| 4—Compound Rest Screw and Cross Feed Screw..... | Remove two screws in compound rest top and one screw in cross slide to oil. Oil once a day. |
| 5—Tailstock Screw..... | Fill both oil cups once a day. Place a drop of oil on center each time work is put between centers. |
| 6—Lead Screw Bearings..... | Fill the oil cup once a day. |
| 7—Lead Screw and Half Nuts..... | Oil every hour when in use. |
| 8—Apron Bearings..... | Fill all oil cups once a day. |
| 9—Gear Box Bearings..... | Fill all oil cups once a day. |
| 10—Primary Gears..... | Fill all oil holes once a day. |
| 11—Reverse Lever..... | Oil the two studs and fill oiler above handle once a day. |
| 12—Back Gears..... | Remove oil hole plug and oil reservoir once a day. |
| 13—Spindle Cone Pulley..... | Remove small screw in cone pulley and fill oil reservoir twice a day first week. Once a day thereafter. |

SOUTH BEND LATHE WORKS - - SOUTH BEND, INDIANA, U. S. A.