

Naval Education and  
Training Command

NAVEDTRA 12204-A  
September 1993  
0502-LP-477-5600

Training Manual  
(TRAMAN)



---

# Machinery Repairman

**DISTRIBUTION STATEMENT A: Approved for public release; distribution is unlimited.**

Nonfederal government personnel wanting a copy of this document  
must use the purchasing instructions on the inside cover.

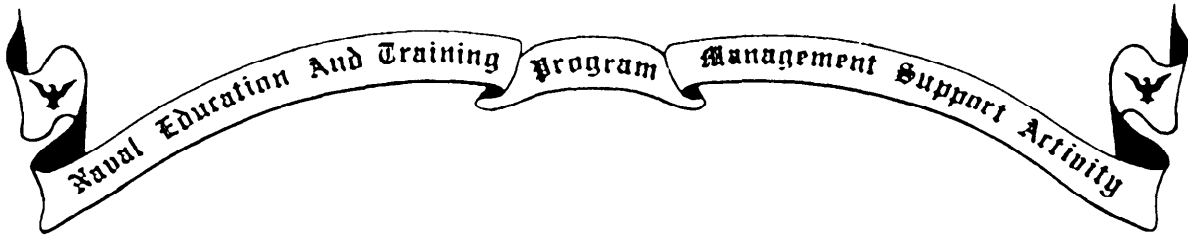


0502LP4775600

Although the words “he,” “him,” and “his” are used sparingly in this manual to enhance communication, they are not intended to be gender driven nor to affront or discriminate against anyone reading this text.

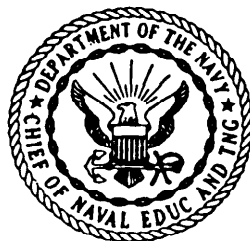
**DISTRIBUTION STATEMENT A: Approved for public release; distribution is unlimited.**

**Nonfederal government personnel wanting a copy of this document must write to Superintendent of Documents, Government Printing Office, Washington, DC 20402 OR Commanding Officer, Naval Publications and Forms Directorate, Navy Aviation Supply Office, 5801 Tabor Avenue, Philadelphia, PA 19120-5099, Attention: Cash Sales, for price and availability.**



# MACHINERY REPAIRMAN

NAVEDTRA 12204-A



*1993 Edition Prepared by  
MRC S Wayne T. Drew*



COMMANDING OFFICER  
NETPDTC  
6490 SAUFLEY FIELD RD  
PENSACOLA, FL 32509-5237

ERRATA #1

18 April 2000

Specific Instructions and Errata for the  
TRAMAN

MACHINERY REPAIRMAN, NAVEDTRA 12204-A

1. No attempt has been made to issue corrections for errors in typing, punctuation, etc.

2. Make the following changes to the Machinery Repairman text:

<u>Page</u>	<u>Column</u>	<u>Paragraph</u>	<u>Change</u>
2-2	1	3rd complete paragraph	Change paragraph to read as follows: "If a dimension is given as 3.000 inches, the . . . is $\pm 0.005$ inch; or if the dimension . . . is $\pm 0.010$ inch." vice "If a dimension is given as 3.000 inches., the . . . is $\pm 0.0005$ inch; or if the dimension . . . is $\pm 0.005$ inch."
5-6	1	1	Change line six to read "blotter may be no more than 0.025 inch thick and a" vice "blotter may be no more than 0.0025 inch thick and a."
7-12	1	last line	Change formula to read as follows:  $\frac{40}{N} = \frac{40}{8} = 5 \text{ turns}$
11-8	2	Figure 11-10	Change top "X AXIS" in figure to read "Z AXIS."
12-3	2	Figure 12-4	Change figure caption to read as follows: "Powder feed unit." vice "Power feed unit."
13-4	2	Number 6	Change number 6. to read as follows: "6. Face, center drill, and drill the end of the shaft. The diameter of the hole should be about 1/4 of the diameter of the shaft; the depth of the hole should be at 5/8 inch per inch of shaft diameter minus 1/8 inch."
13-4	2	Number 8	Change number 8, line 2 to read as follows: "The stub should be 1/8 inch larger in diameter and 3/8."

3. Wherever you see "Blueprint Reading and Sketching, NAVEDTRA 10077-F1," in the text, change it to read "Blueprint Reading and Sketching, NAVEDTRA 12014."

4. Wherever you see "Navy Occupational Safety and Health (NAVOSH) Program Manual for Forces Afloat, OPNAV 51.000.19B," in the text, change it to read "Navy Occupational Safety and Health (NAVOSH) Program Manual for Forces Afloat, OPNAV 51.000.19."



# PREFACE

This Training Manual (TRAMAN) and Nonresident Training Course (NRTC) form a self-study package to teach the theoretical knowledge and mental skills needed by a Machinery Repairman. This package may be combined with on-the-job training to provide the necessary elements of practical experience and observation of techniques demonstrated by more senior Machinery Repairmen.

Completion of the NRTC is the usual way to satisfy the requirement to complete the TRAMAN. Learning objectives are included at the beginning of each chapter of the TRAMAN. Assignments in the NRTC have supporting questions to help the student learn the materials in the TRAMAN.

## SCOPE OF REVISION

This training manual contains the following major revisions: Chapter 5 has new material on grinding hand tools and sharpening twist drills, and on the selection and use of carbide tooling. Chapter 11 has new material on computer numerical control machines. Chapter 15 has new material on heat treating. Information on obsolete equipment such as the horizontal turret lathe has been deleted.

1993 Edition

**Stock Ordering No.  
0502-LP-477-5600**

Published by  
NAVAL EDUCATION AND TRAINING PROGRAM  
MANAGEMENT SUPPORT ACTIVITY

UNITED STATES  
GOVERNMENT PRINTING OFFICE  
WASHINGTON, D.C.: 1993

# **THE UNITED STATES NAVY**

## **GUARDIAN OF OUR COUNTRY**

The United States Navy is responsible for maintaining control of the sea and is a ready force on watch at home and overseas, capable of strong action to preserve the peace or of instant offensive action to win in war.

It is upon the maintenance of this control that our country's glorious future depends; the United States Navy exists to make it so.

## **WE SERVE WITH HONOR**

Tradition, valor, and victory are the Navy's heritage from the past. To these may be added dedication, discipline, and vigilance as the watchwords of the present and the future.

At home or on distant stations as we serve with pride, confident in the respect of our country, our shipmates, and our families.

Our responsibilities sober us; our adversities strengthen us.

Service to God and Country is our special privilege. We serve with hona.

## **THE FUTURE OF THE NAVY**

The Navy will always employ new weapons, new techniques, and greater power to protect and defend the United States on the sea, under the sea, and in the air.

Now and in the future, control of the sea gives the United States her greatest advantage for the maintenance of peace and for victory in war.

Mobility, surprise, dispersal, and offensive power are the keynotes of the new Navy. The roots of the Navy lie in a strong belief in the future, in continued dedication to our tasks, and in reflection on our heritage from the past.

Never have our opportunities and our responsibilities been greater.

# CONTENTS

CHAPTER	PAGE
1. Toolrooms and Tools . . . . .	1-1
2. Layout and Benchwork . . . . .	2-1
3. Metals and plastics . . . . .	3-1
4. Power Saws and Drilling Machines . . . . .	4-1
5. Offhand Grinding of Tools and Selection of Carbide Tools . . . . .	5-1
6. Engine Lathes . . . . .	6-1
7. Milling Machines and Milling Operations . . . . .	7-1
8. Vertical Turret Lathe and Horizontal Boring Mill . . . . .	8-1
9. Shapers, Planers, and Engravers . . . . .	9-1
10. Precision Grinding Machines . . . . .	10-1
11. Computer Numerical Control Machines . . . . .	11-1
12. Metal Buildup . . . . .	12-1
13. Repair Work. . . . .	13-1
14. Gears and Gear Cutting . . . . .	14-1
15. Metallurgy and Heat Treating . . . . .	15-1
APPENDIX	
I. Glossary . . . . .	AI-1
II. Tabular Information of Benefit to a Machinery Repairman . . . . .	AII-1
III. Formulas for Spur Gearing . . . . .	AIII-1
IV Derivation Formulas for Diametral Pitch System . . . . .	AIV-1
V. References Used To Develop The TRAMAN . . . . .	AV-1
INDEX . . . . .	INDEX-1



# CHAPTER 1

## TOOLROOMS AND TOOLS

### CHAPTER LEARNING OBJECTIVES

*Upon completing this chapter, you should be able to do the following:*

- *Describe toolroom organization.*
- *Explain how to inspect tools for damage.*
- *State the process used to issue tools.*
- *Describe the use of measuring tools in shop manufacture.*
- *Describe the procedure used to check the accuracy of measuring instruments.*

Before we discuss toolrooms and tools, we'll give you an overview of the Machinery Repairman (MR) rating.

The official description of the scope of the MR rating is to "perform organizational and intermediate maintenance on assigned equipment and in support of other ships, requiring the skillful use of lathes, milling machines, boring mills, grinders, power hacksaws, drill presses, and other machine tools; portable machinery; and handtools and measuring instruments found in a machine shop." That is a very general statement not meant to define completely the types of skills and supporting knowledge that an MR is expected to have in the different paygrades.

The job of restoring machinery to good working order, ranging from the fabrication of a simple pin or bushing to the complete rebuilding of an intricate gear system, requires skill of the highest order at each task level. Often, in the absence of dimensional drawings or other design information, an MR must depend upon ingenuity and know-how to successfully fabricate a repair part.

One of the important characteristics you will gain from becoming a well-trained and skilled MR is versatility. As you gain knowledge and skill in the operation of the many different types of machines found in Navy machine shops, you will realize that even though a particular machine is used mostly for

certain types of jobs, it may be capable of accepting many others. Your imagination will probably be your limiting factor; and if you keep your eyes, ears, and mind open, you will discover that there are many things going on around you that can broaden your base of knowledge. You will find pleasure and pride in developing new and more efficient ways to do something that has become so routine everyone else simply accepts the procedure currently being used as the only one that will work.

The skill acquired by an MR in the Navy is easily translated into several skills found in the machine shops of private industry. In fact, you'd be surprised at the depth and range of your knowledge and skill compared to your civilian counterpart, based on a somewhat equal length of experience. The machinist trade in private industry breaks job descriptions into many different titles and skill levels.

The beginning skill level and one in which you will surely become qualified is machine tool operator, a job often done by semiskilled workers. The primary requirement of the job is to observe the operation, disengage the machine in case of problems, and possibly maintain manual control over certain functions. Workers who do these jobs usually have the ability to operate a limited number of different types of machines.

Another job description found in private industry is layout man. The requirement of this job is to lay out work that is to be machined by someone else. An understanding of the operation and capabilities of the different machines is required, as well as the ability to read blueprints. As you progress in your training in the MR rating you will become proficient in interpreting blueprints and in planning the required machining operations. You will find that laying out intricate parts is not so difficult with this knowledge.

A third job description is set-up man, a job that requires considerable knowledge and skill, all within what you can expect to gain as a MR. A set-up man is responsible for placing each machine accessory and cutting tool in the exact position required to permit accurate production of work by a machine tool operator.

An all-around machinist in private industry is the job for which the average MR would qualify as far as knowledge and skill are concerned. This person is able to operate all machines in the shop and manufacture parts from blueprints. Some MRs will advance their knowledge and skills throughout their Navy career to the point that they can move into a job as a tool and die maker with little trouble. They also acquire a thorough knowledge of engineering data related to design limitations, shop math, and metallurgy. There are many other related fields in which an experienced MR could perform—instrument maker, research and development machinist, toolroom operator, quality assurance inspector and, of course, the supervisory jobs such as foreman or superintendent.

The obvious key to holding down a position of higher skill, responsibility, and pay is the same both in the Navy and in private industry. You must work hard, take advantage of the skills and knowledge of those around you, and take pride in what you do regardless of how unimportant it may seem to you. You have a great opportunity ahead of you as an MR in the Navy; a chance to make your future more secure than it might have been.

Your proficiency as an MR is greatly influenced by your knowledge of tools and your skills in using them. You will need to become familiar with the correct use and care of the many powered and nonpowered handtools, measuring instruments, and gauges you will use in your job.

This training manual will provide information on the tools and instruments used primarily by an MR. You can find additional information on tools used by the many different naval ratings in *USE and CARE of HAND TOOLS and MEASURING TOOLS*, NAVEDTRA 12085.

## **TOOLROOM SAFETY**

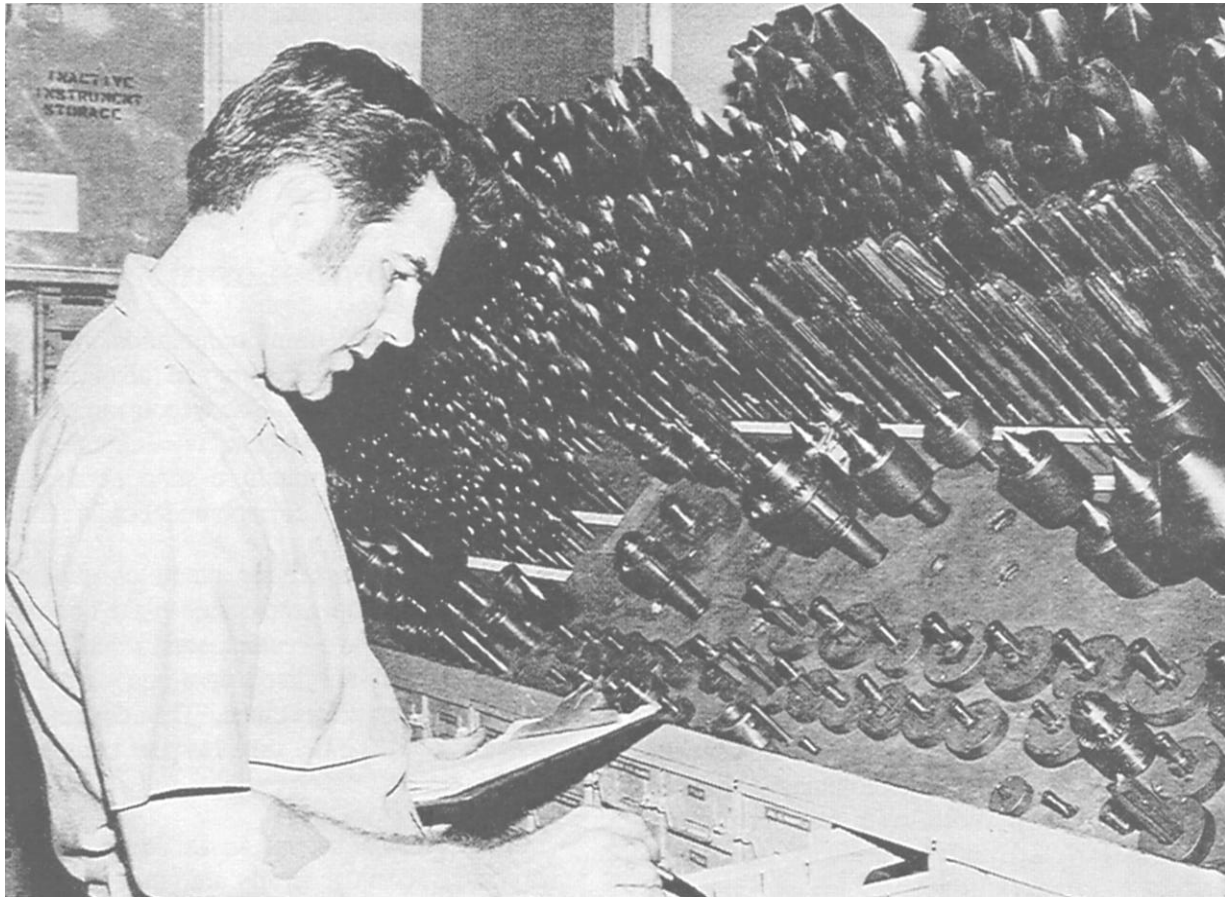
The toolroom is relatively small, and a large quantity of different tools are stored there. It can become very dangerous if all items are not kept stored in their proper places. At sea the toolroom can be especially hazardous if you don't secure all drawers, bins, pegboards, and other storage facilities. Fire hazards are sometimes overlooked in the toolroom. When you consider the flammable liquids and wiping rags stored in or issued from the toolroom, you realize there is a real danger present.

As a toolroom keeper, you play a very important part in creating a safe working environment. Several of your jobs are directly connected to the good working order and safe use of tools in the shop. If you issue an improperly ground twist drill to someone who does not have the experience to recognize the defect, the chances of the person being injured if the drill "digs in" or throws the workpiece out of the drill press would be very real. A wrench that has been sprung or worn oversize can become a real "knucklebuster" to any unsuspecting user. An outside micrometer out of calibration can cause trouble when someone is trying to press fit two parts together using a hydraulic press. The list of potential disasters that you can prevent is endless. The important thing to remember is that you as a toolroom keeper contribute more to the mission of the Navy than first meets the eye. If you are ever in doubt concerning toolroom safety, consult your supervisor or *Navy Occupational Safety and Health (NAVOSH) Program Manual for Forces Afloat*, OPNAVINST 5100.19B.

## **TOOLROOM ORGANIZATION**

You may be given responsibility for the operation of the tool crib or tool-issuing room. Make sure that the necessary tools are available and in good condition and that an adequate supply of consumable items (oil, wiping rags, bolts, nuts, and screws) is available.

It's easy to operate and maintain a toolroom if the correct procedures and methods are used to set up the



28.333.1

Figure 1-1.—Method of tool storage.

system. Some of the basic considerations are (1) the issue and custody of tools; (2) replacement of broken, worn, or lost tools; and (3) proper storage and maintenance of tools.

Shipboard toolrooms are limited in size by the design of the ship. Therefore, the space must be used as efficiently as possible. Since the number of tools required aboard ship is extensive, toolrooms usually tend to be overcrowded. Certain peculiarities in shipboard toolrooms also require consideration. For example, the motion of the ship at sea requires that tools be made secure to prevent movement. The moisture in the air requires that the tools be protected from corrosion.

It's difficult to change permanent bins, shelves, and drawers in the toolroom. However, you can reorganize existing storage spaces by dividing larger bins and relocating tools to provide better use of space.

Hammers, wrenches, and other tools that do not have cutting edges are normally stored in bins. They also may be segregated by size or other designation. Tools with cutting edges require more space to prevent damage to the cutting edges. These tools are stored on shelves lined with wood or felt, on pegboards, or on hanging racks. Pegboards are especially adaptable for tools such as milling cutters. Make provisions to keep these tools from falling off the boards when the ship is rolling. Store precision tools (micrometers, dial indicators, and so forth) in felt-lined wooden boxes in a cabinet to reduce the effects of vibration. This arrangement allows a quick daily inventory. It also prevents the instruments from being damaged by contact with other tools. Use rotating bins to store large supplies of small parts, such as nuts and bolts. Rotating bins provide rapid selection from a wide range of sizes. Figures 1-1,

1-2, and 1-3 show some of the common methods of tool storage.

Place frequently used tools near the issuing door so they are readily available. Place seldom used tools in out of the way areas such as on top of bins or in spaces that cannot be used efficiently because of size and shape. Place heavy tools in spaces or areas where a minimum of lifting is required.

Mark all storage areas such as bins, drawers, and lockers clearly to help locate tools. Make these markings permanent- either stencil them with paint or mark them with stamped metal tags.

### TOOL INSPECTION

If you are the toolroom keeper, you'll be responsible for the condition of all the tools and equipment in the toolroom. This is a very important job. Inspect all tools as they are returned to determine if they need repairs or adjustment. NEVER issue damaged tools since they may harm shop equipment or personnel. Set aside a space for damaged tools to prevent issue of these tools until they have been repaired. Send any dull cutting tools to the grind shop for regrinding. Properly dispose of any cutting tools that can't be reground.

Wipe clean all returned tools and give their metal surfaces a light coat of oil. Check all precision tools upon issue and return to determine if they are

accurate. Keep all spaces clean and free of dust to prevent foreign matter from getting into the working parts of tools. Plan to spend a portion of each day reconditioning damaged tools. This keeps the tools available for issue and prevents an accumulation of damaged tools.

### CONTROL OF TOOLS

There are two common methods of tool issue control: the tool check system and the mimeographed form or tool chit system. Some toolrooms may use a combination of these systems. For example, you may use tool checks for machine shop personnel, and mimeographed forms for personnel outside the shop.

Tool checks are either metal or plastic disks stamped with numbers that identify the borrower. In this system the borrower presents a check for each tool, and the disk is placed on a peg near the space from which the tool was taken. The advantage of this system is that very little time is spent completing the process.

If the tools are loaned to all departments in the ship, printed forms generally are used. The form has a space to list the tools, the borrower's name, the division or department, and the date. This system allows anyone in the ship's crew to borrow tools, and it keeps the toolroom keeper informed as to who has the tools and how long they have been out.

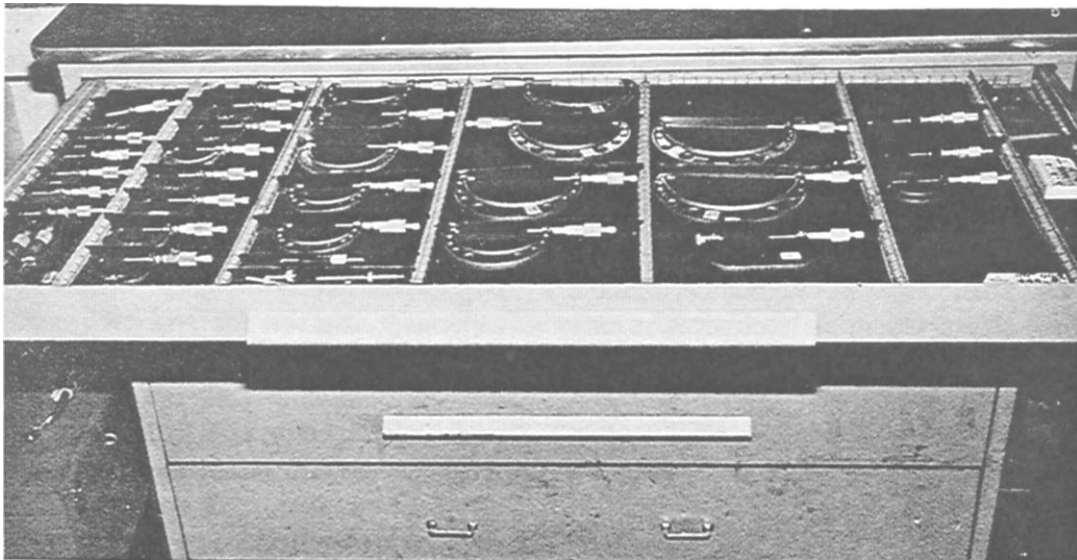
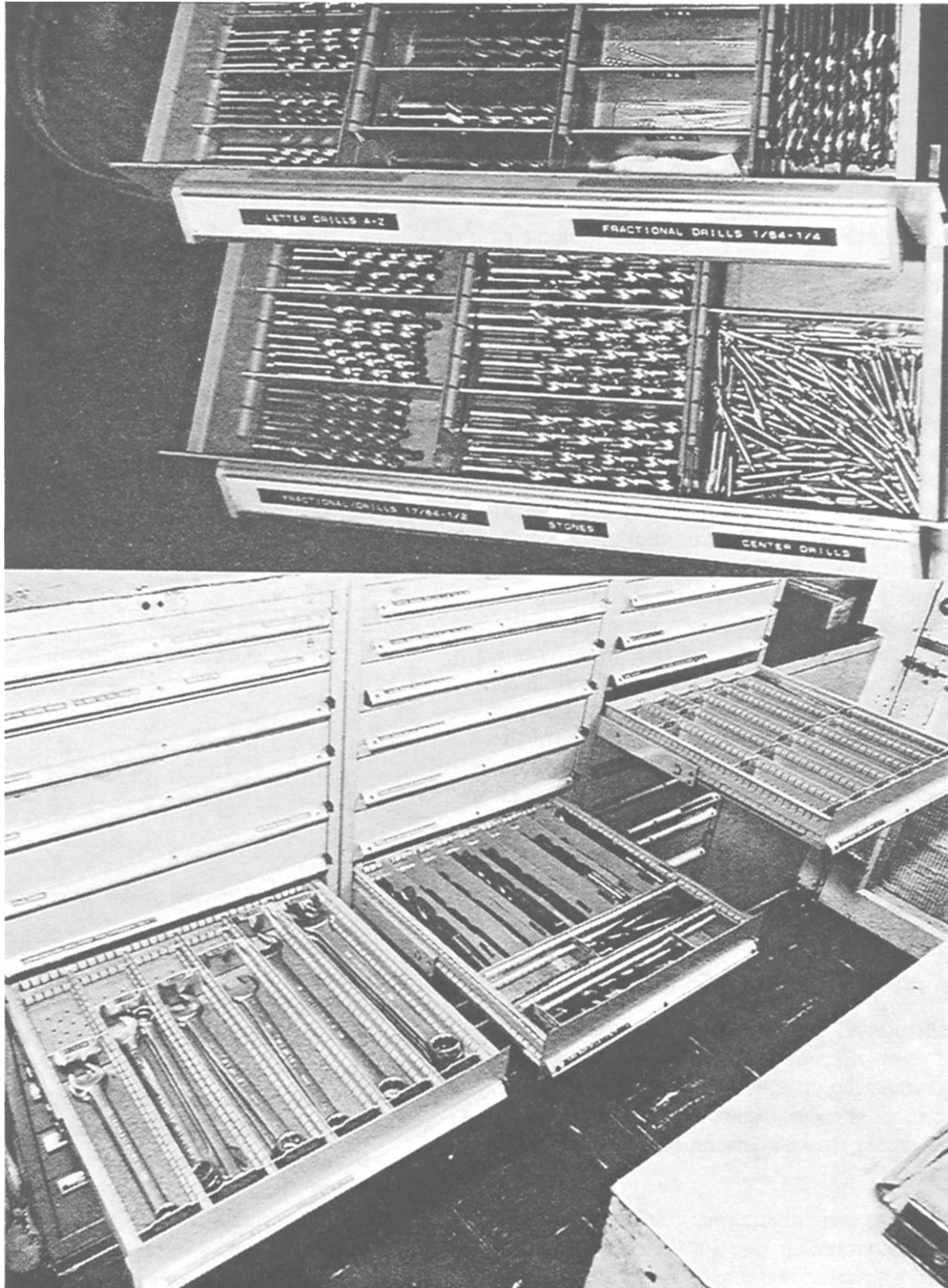


Figure 1-2.—Method of tool storage.

28.334



28.335

Figure 1-3.—Method of tool storage.

You must know the location of tools and equipment out on loan, how long tools have been out, and the amount of equipment and consumable supplies you have on hand. To know this, you'll have to make periodic inventories. The inventory consists of a count of all tools, by type, in the toolroom and those out on loan. Inventories help you decide whether more strict control of equipment is needed and if you need to procure more tools and equipment.

Some selected items, called controlled equipment, will require an increased level of management and control due to their high cost, vulnerability to pilferage, or importance to the ship's mission. The number of tools and instruments in this category is generally small. However, it is important that you be aware of controlled equipment items. You can get detailed information about the designation of controlled equipment from the supply department of your activity. When these tools are received from the supply department, your department head will be required to sign a custody card for each item, indicating a definite responsibility for management of the item. The department head will then require signed custody cards from personnel assigned to the division or shop where the item will be stored and used. As a toolroom keeper, you may control the issue of these tools and ensure their good condition. If these special tools are lost or broken beyond repair, you cannot replace them until the correct survey procedures have been completed. Conduct formal inventories of these items periodically as directed by your division officer or department head.

## MEASURING INSTRUMENTS

Practically all shop jobs require measuring or gauging. You will most likely measure or gauge flat or round stock; the outside diameters of rods, shafts, or bolts; slots, grooves, and other openings; thread pitch and angle; spaces between surfaces; or angles and circles.

For some of these operations, you'll have a choice of which instrument to use, but in other instances you'll need a specific instrument. For example, when precision is not important, a simple rule or tape will be suitable. In other instances, when precision is important, you'll need a micrometer.

The term gauge, as used in this chapter identifies any device that can be used to determine the size or shape of an object. There is no significant difference between gauges and measuring instruments. They are

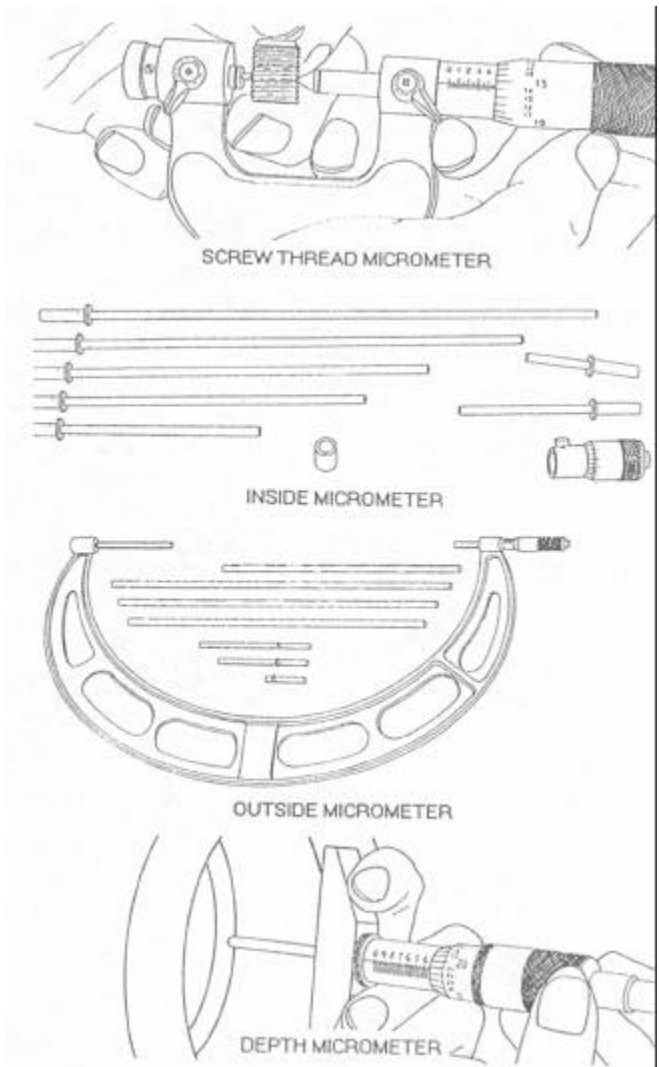


Figure 1-4.—Common types of micrometers.

both used to compare the size or shape of an object against a scale or fixed dimension. However, there is a distinction between measuring and gauging that is easily explained by an example. Suppose you are turning work on a lathe and want to know the diameter of the work. Take a micrometer, or perhaps an outside caliper, adjust its opening to the exact diameter of the workpiece, and determine that dimension numerically. On the other hand, if you want to turn a piece of work down to a certain size without frequently taking time to measure it, set the caliper at a reading slightly greater than the final dimension; then, at intervals during turning operations, gauge, or "size," the workpiece with the locked instrument. After you have reduced the workpiece dimension to the dimension set on the instrument, you will, of course, need to measure the work as you finish it to the exact dimension.

## ADJUSTABLE GAUGES

You can adjust adjustable gauges by moving the scale or by moving the gauging surface to the dimensions of the object being measured or gauged. For example, on a dial indicator, you can adjust the face to align the indicating hand with the zero point on the dial. On verniers, however, you move the measuring surface to the dimensions of the object being measured.

### Micrometers

Micrometers are probably the most used precision measuring instruments in a machine shop. There are many different types, each designed to measure surfaces for various applications and configurations of workpieces. The degree of accuracy also varies, with the most common graduations ranging from one-thousandth (0.001) of an inch to one ten-thousandth (0.0001) of an inch. You'll find information on the procedure used to interpret the readings on micrometers in *USE and CARE of HAND TOOLS and MEASURING TOOLS*, NAVEDTRA 12085. We have provided brief descriptions of the more common types of micrometers in the following paragraphs.

**OUTSIDE MICROMETER.**—Outside micrometers (figs. 1-4 and 1-5), are used to measure the thickness or the outside diameter of parts. They are available in sizes ranging from 1 inch to about 96 inches in steps of 1 inch. The larger sizes normally come as a set with interchangeable anvils that provide a range of several inches. The anvils have an adjusting nut and a locking nut to allow you to set the micrometer with a micrometer standard. Regardless of the degree of accuracy designed into the micrometer, the skill applied by each individual is the primary factor in determining accuracy and reliability in measurements. Training and practice will make you proficient in using this tool.

**INSIDE MICROMETER.**—An inside micrometer (fig. 1-4) is used to measure inside diameters or between parallel surfaces. They are available in sizes ranging from 0.200 inch to over 100 inches. The individual interchangeable extension rods that may be assembled to the micrometer head vary in size by 1 inch. A small sleeve or bushing, which is 0.500 inch long, is used with these rods in most inside micrometer sets to provide the complete range of sizes. It's slightly more difficult to use the inside micrometer than the outside micrometer—there is more chance that you won't get the same "feel" or measurement each time you check the same surface.

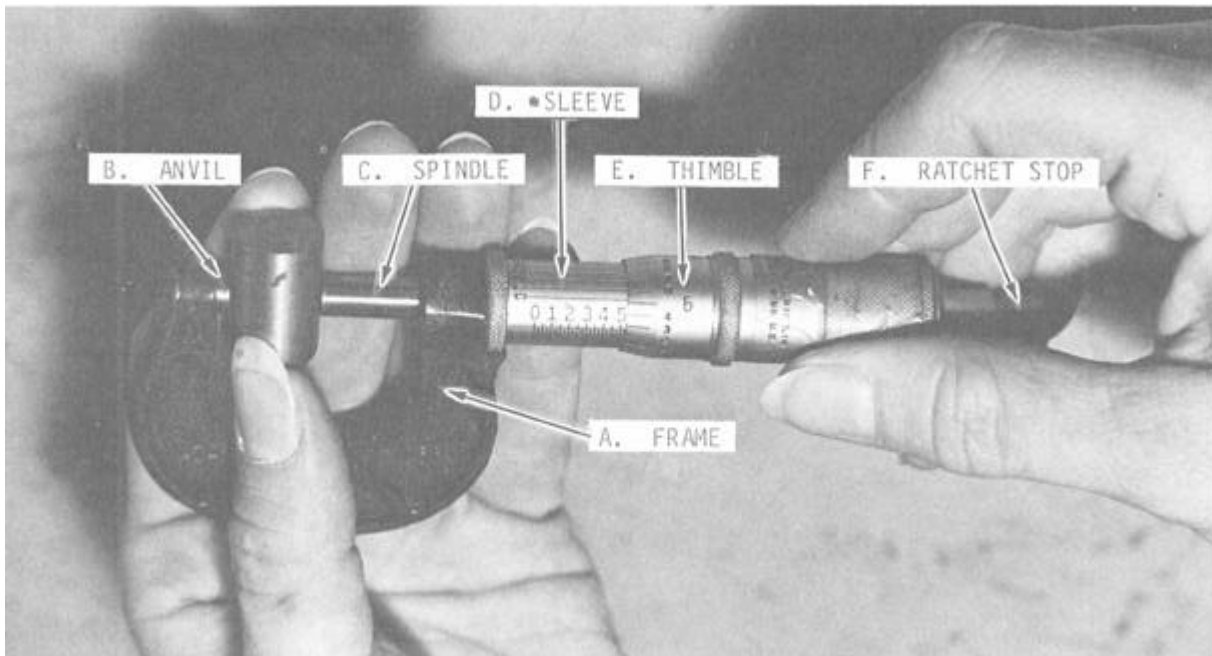


Figure 1-5.—Nomenclature of an outside micrometer caliper.

28.321

The correct way to measure an inside diameter is to hold the micrometer in place with one hand as you feel for the maximum possible setting of the micrometer by rocking the extension rod from left to right and in and out of the hole. Adjust the micrometer to a slightly larger measurement after each series of rocking movements until you can no longer rock the rod from left to right. At that point, you should feel a very slight drag on the in and out movement. There are no specific guidelines on the number of positions within a hole that should be measured. If you are checking for taper, take measurements as far apart as possible within the hole. If you are checking for roundness or concentricity of a hole, take several measurements at different angular positions in the same area of the hole. You may take the reading directly from the inside micrometer head, or you may use an outside micrometer to measure the inside micrometer.

**DEPTH MICROMETER.**—A depth micrometer (fig. 1-4) is used to measure the depth of holes, slots, counterbores, and recesses, and the distance from a surface to some recessed part. This type of micrometer is read exactly opposite from the method used to read an outside micrometer. The zero is located toward the closed end of the thimble. The measurement is read in reverse and increases in amount (depth) as the thimble moves toward the base of the instrument. The extension rods come either round or flat (blade-like) to permit measuring a narrow, deep recess or grooves.

**THREAD MICROMETER.**—The thread micrometer (fig. 1-4) is used to measure the depth of threads that have an included angle of  $60^\circ$ . The measurement obtained represents the pitch diameter of the thread. They are available in sizes that measure pitch diameters up to 2 inches. Each micrometer has a given range of number of threads per inch that can be measured correctly. You'll find additional information on this micrometer in chapter 6.

**BALL MICROMETER.**—This type of micrometer (not shown) has a rounded anvil and a flat spindle. It's used to check the wall thickness of cylinders, sleeves, rings, and other parts that have a hole bored in a piece of material. The rounded anvil is placed inside the hole and the spindle is brought into contact with the outside diameter. Ball attachments that fit over the anvil of regular outside micrometers are also available. When using the attachments, you must compensate for the diameter of the ball as you read the micrometer.

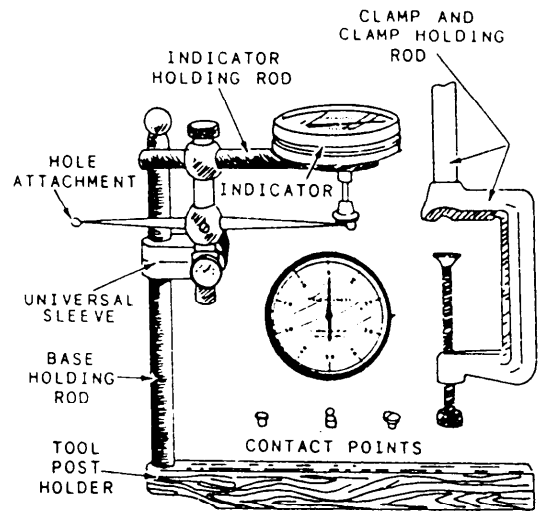


Figure 1-6.—Universal dial indicator.

**BLADE MICROMETER.**—A blade micrometer (not shown) has an anvil and a spindle that are thin and flat. The spindle does not rotate. This micrometer is especially useful in measuring the depth of narrow grooves, such as an O-ring seat on an outside diameter.

**GROOVE MICROMETER.**—A groove micrometer (not shown) looks like an inside micrometer with two flat disks. The distance between the disks increases as you turn the micrometer. It is used to measure the width of grooves or recesses on either the outside or the inside diameter. The width of an internal O-ring groove is an excellent example of a groove micrometer measurement.

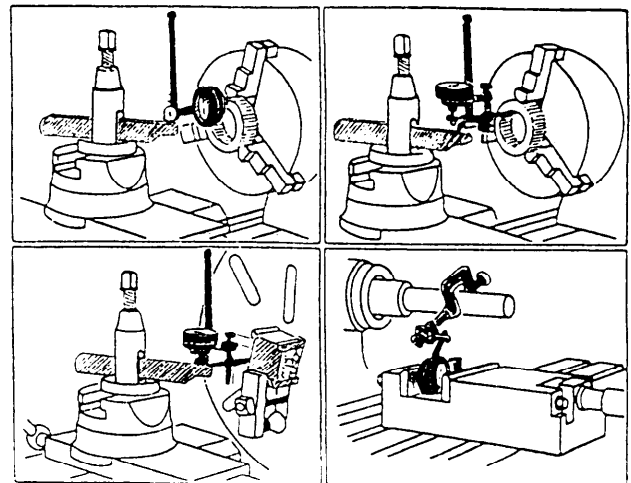


Figure 1-7.—Applications of a dial indicator.



## Dial Indicator

MRs use dial indicators to set up work in machines and to check the alignment of machinery. You'll need a lot of practice to become proficient in the use of this instrument. You should use it as often as possible to help you do more accurate work.

Dial indicator sets (fig. 1-6) usually have several components that permit a wide variation of uses. For example, the contact points allow use on different types of surfaces, the universal sleeve permits flexibility of setup, the clamp and holding rods permit setting the indicator to the work, the hole attachment indicates variation or run out of inside surfaces of holes, and the tool post holder can be used in lathe setups. Figure 1-7 shows some practical applications of dial indicators.

Dial indicators come in different degrees of accuracy. Some will give readings to one ten-thousandth (0.0001) of an inch, while others will

indicate to only one five-thousandth (0.005) of an inch. Dial indicators also differ in the total range or amount they will indicate. If a dial indicator has a total of one hundred-thousandth (0.100) of an inch in graduations on its face and has a total range of two hundred-thousandths (0.200) of an inch, the needle will only make two revolutions before it begins to exceed its limit and jams up. The degree of accuracy and range of a dial indicator is usually shown on its face. Before you use a dial indicator, carefully depress the contact point and release it slowly; rotate the movable dial face so the dial needle is on zero. Depress and release the contact point again and check to make sure the dial pointer returns to zero; if it does not, have the dial indicator checked for accuracy.

## Vernier Caliper

You can use a vernier caliper (fig. 1-8) to measure both inside and outside dimensions. Position the

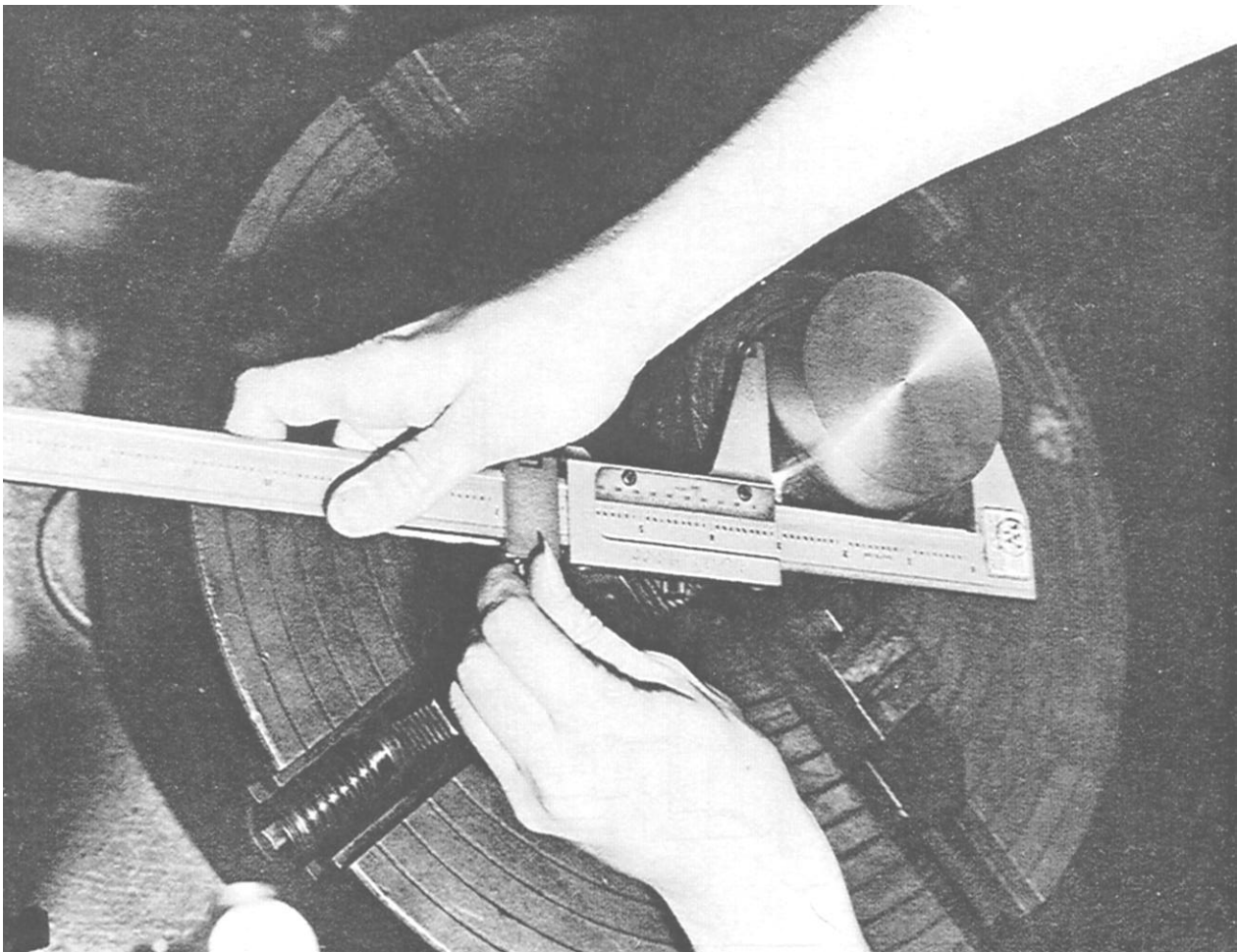


Figure 1-8.—Vernier caliper.

28.314

appropriate sides of the jaws on the surface to be measured and read the caliper from the side marked inside or outside as required. There is a difference in the zero marks on the two sides that is equal to the thickness of the tips of the two jaws, so be sure to read the correct side. Vernier calipers are available in sizes ranging from 6 inches to 6 feet and are graduated in increments of thousandths (0.001) of an inch. The scales on vernier calipers made by different manufacturers may vary slightly in length or number of divisions; however, they are read basically the same way. See *USE and CARE of HAND TOOLS and MEASURING TOOLS*, NAVEDTRA 12085, for instructions on how to interpret the readings.

### Vernier Height Gauge

A vernier height gauge (fig. 1-9) is used to lay out work for machining operations or to check the

dimensions on surfaces that have been machined. Attachments for the gauge include the offset scribe shown attached to the gauge in figure 1-9. The offset scribe lets you measure from the surface plate with readings taken directly from the scale without the need for calculations. As you can see in figure 1-9, if you were using a straight scribe, you would have to calculate the actual height by taking into account the distance between the surface plate and the zero mark. Some models have a slot in the base for the scribe to move down to the surface and a scale that permits direct reading. Another attachment is a rod that permits depth readings. Small dial indicators that connect to the scribe permit extremely close work when you check or lay out work. Read a vernier height gauge the same way you read a vernier caliper.

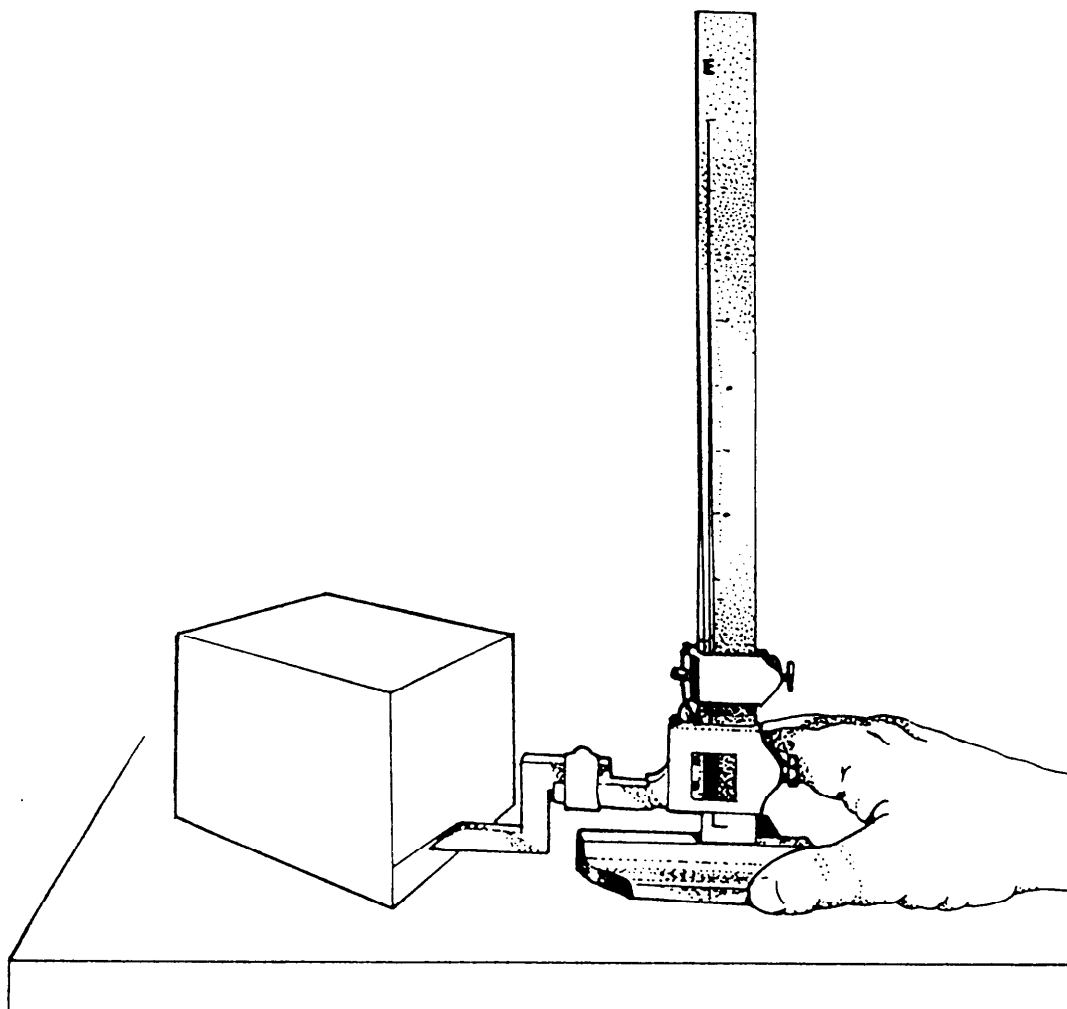
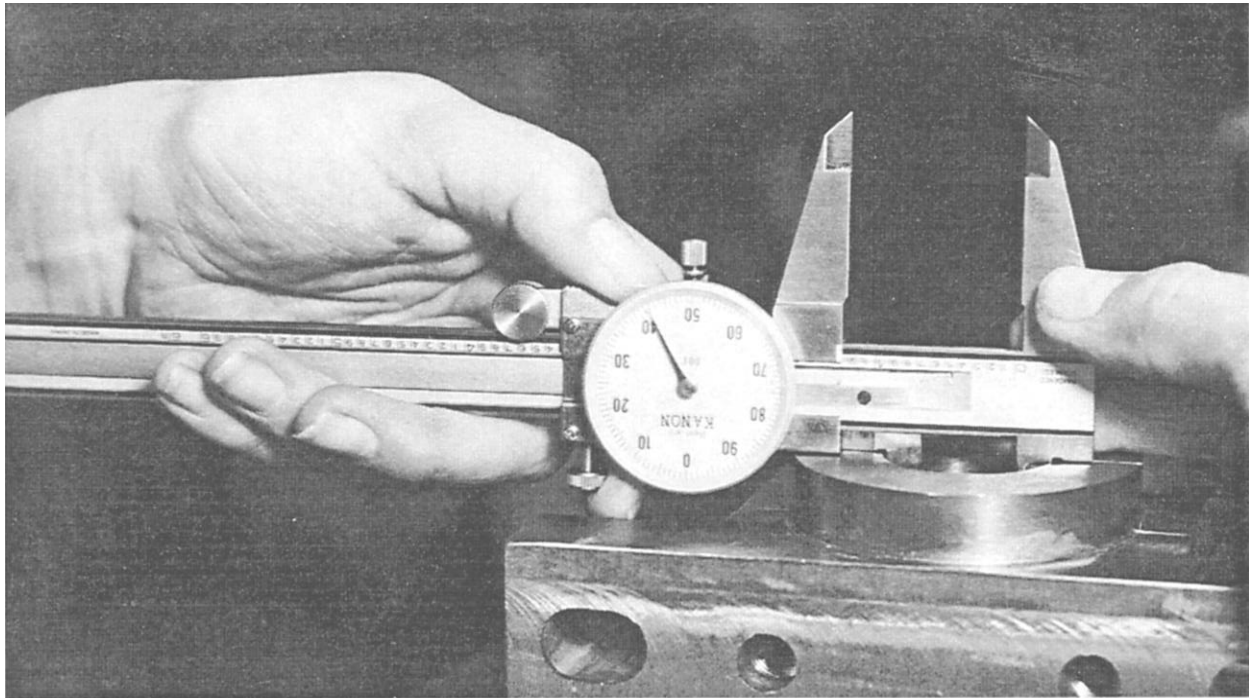


Figure 1-9.—Vernier height gauge.

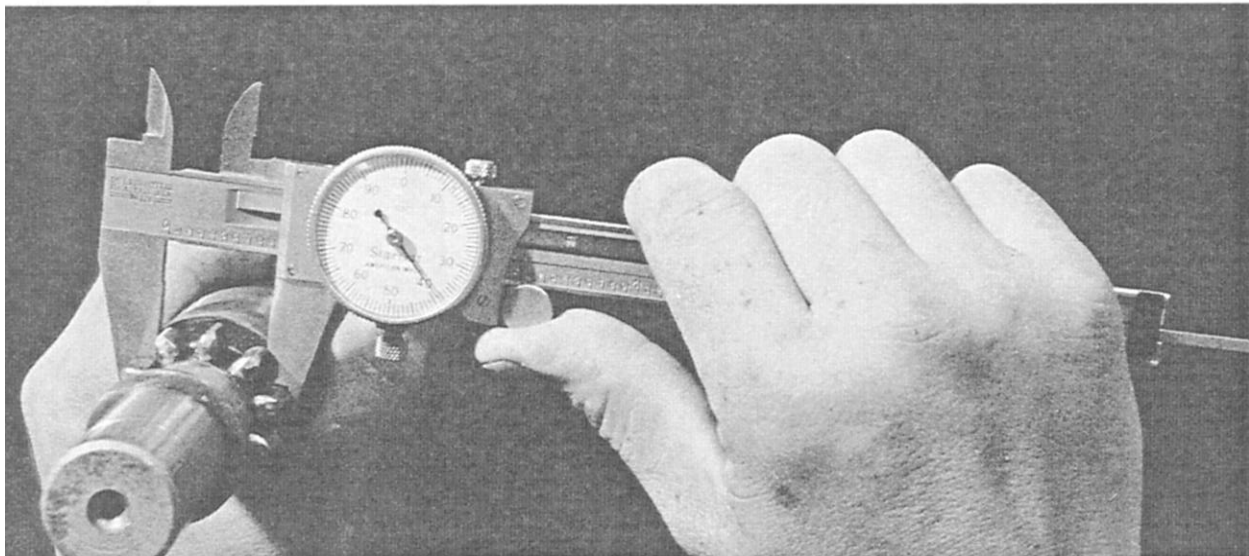
## Dial Vernier Caliper

A dial vernier caliper (fig. 1-10) looks much like a standard vernier caliper and is also graduated in one-thousandths (0.001) of an inch. The main

difference is that instead of a double scale, as on the vernier caliper, the dial vernier has the inches marked only along the main body of the caliper and a dial that indicates thousandths (0.001) of an inch. The range of the dial vernier caliper is usually 6 inches.



A. MEASURING THE INSIDE



B. MEASURING THE OUTSIDE

Figure 1-10.—Dial vernier caliper.

28.315

## Dial Bore Gauge

The dial bore gauge is one of the most accurate tools used to measure a cylindrical bore or check a bore for out-of-roundness or taper, (fig. 1-11). It does not give a direct measurement; it gives you the amount of deviation from a preset size or the amount of deviation from one part of the bore to another. A master ring gauge is used to preset the gauge. A dial bore gauge has two stationary spring-loaded points and an adjustable point to permit a variation in range. These three points are evenly spaced to allow accurate centering of the tool in the bore. A fourth point, the tip of the dial indicator, is located between the two stationary points. By simply rocking the tool in the bore, you can observe the amount of variation on the dial. Most models are accurate to within one ten-thousandth (0.0001) of an inch.

## Internal Groove Gauge

The internal groove gauge (not shown) may be used to measure the depth of an O-ring groove or other recesses inside a bore. This tool lets you measure a deeper recess and one located farther back in the bore than you could with an inside caliper. As with the dial bore gauge, you must set this tool with gauge blocks, a vernier caliper, or an outside micrometer. The reading taken from the dial indicator on the groove gauge represents the difference between the desired recess or groove depth and the measured depth.

## Universal Vernier Bevel Protractor

The universal vernier bevel protractor (fig. 1-12) is used to lay out or measure angles on work to very close tolerances. The vernier scale on the tool permits measuring an angle to within  $1/12^\circ$  (5 minutes) and can be used completely through  $360^\circ$ . Interpreting the reading on the protractor is similar to the method used on the vernier caliper.

## Universal Bevel

The universal bevel (fig. 1-13) has an offset in the blade. The offset makes it useful for bevel gear work and to check angles on lathe workpieces that cannot be reached with an ordinary bevel. Set and check the universal bevel with the protractor, or another suitable angle-measuring device, to get the angle you need.

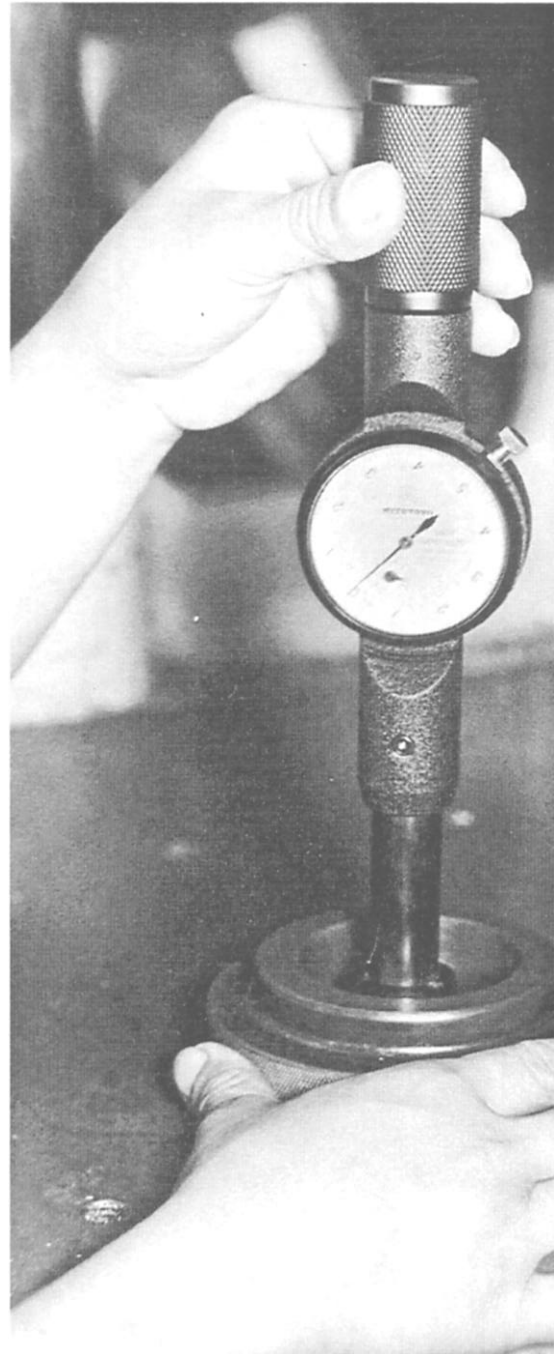


Figure 1-11.—Dial bore gauge.

28.316

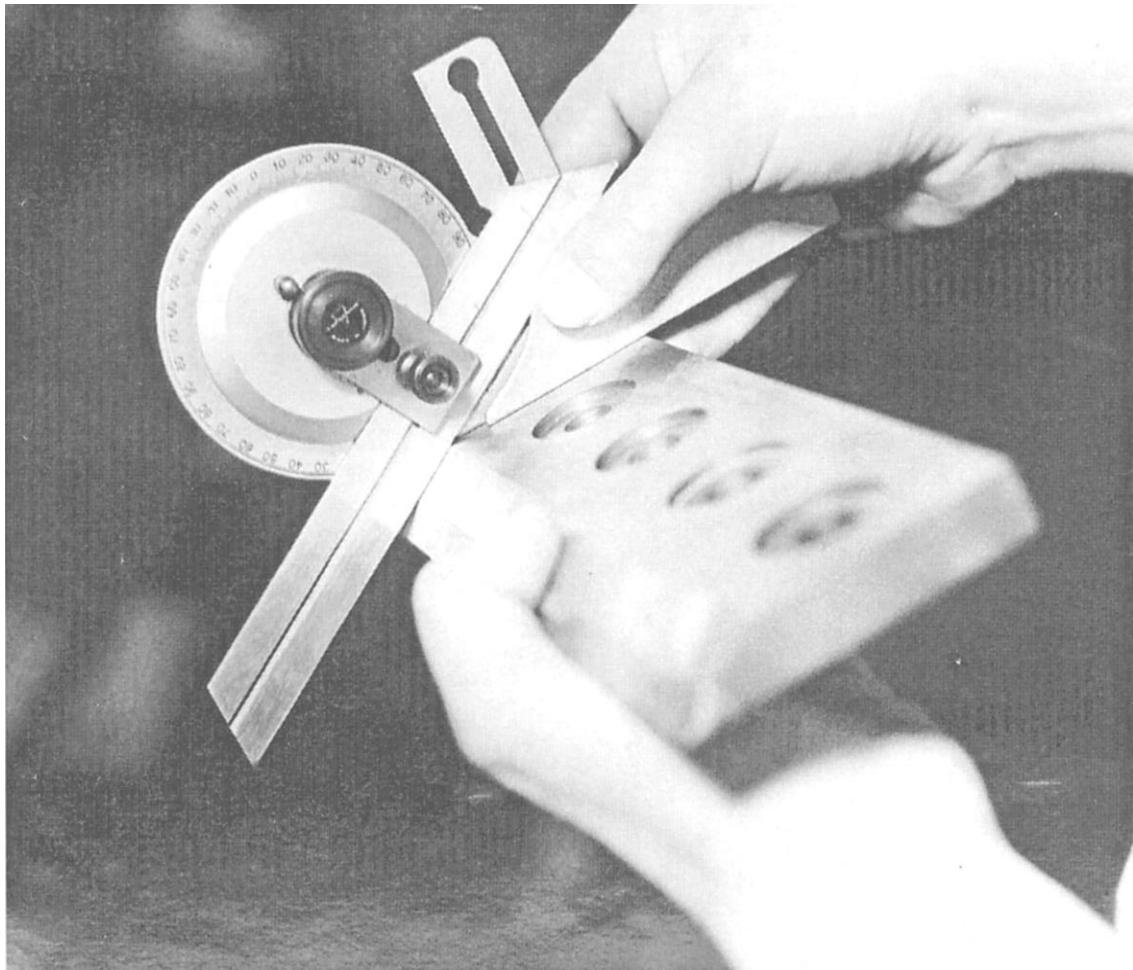


Figure 1-12.—Universal vernier bevel protractor.

28.317

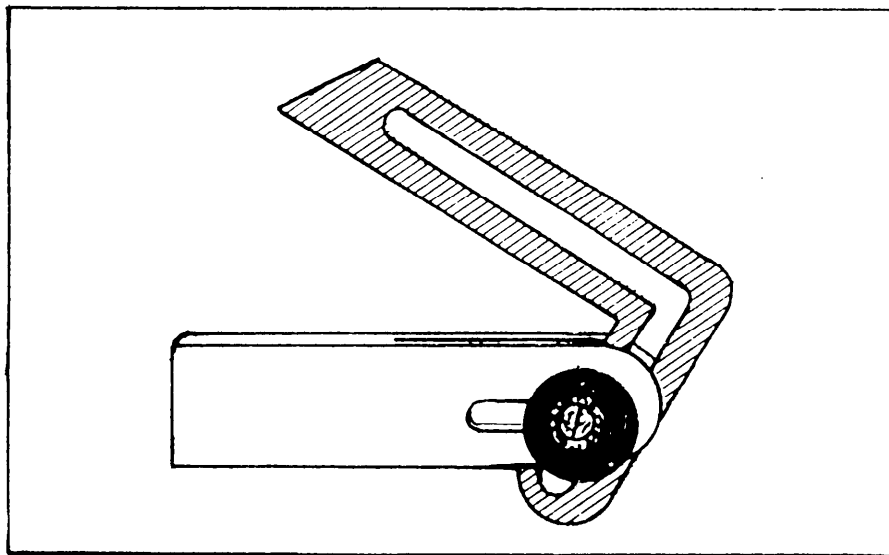
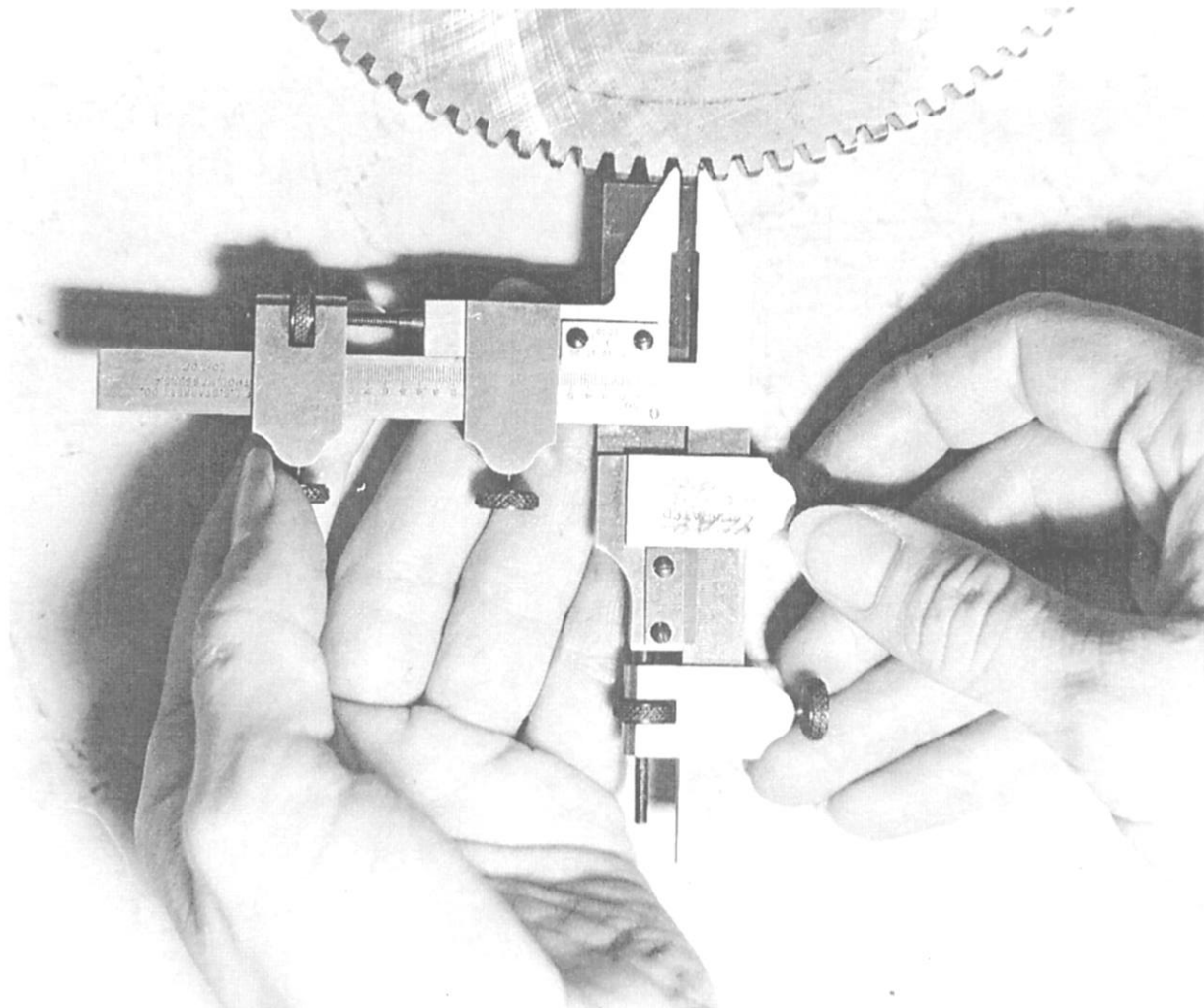


Figure 1-13.—Universal bevel.



28.318

Figure 1-14.—Gear tooth vernier.

### Gear Tooth Vernier

Use a gear tooth vernier (fig. 1-14) to measure the thickness of a gear tooth on the pitch circle and the distance from the top of the tooth to the pitch chord, at the same time. Read the vernier scale on this tool in the same way as other verniers, but note that graduations on the main scale are 0.020 inch apart instead of 0.025 inch.

### Cutter Clearance Gauge

The cutter clearance gauge (fig. 1-15) is one of the simplest to use. You can gauge clearance on all styles of plain milling cutters that have more than 8 teeth and a diameter range from 1/2 inch to 8 inches. To gauge a tooth with this instrument, bring the surfaces of the “V” into contact with the cutter and lower the gauge blade to the tooth to be gauged.

Rotate the cutter sufficiently to bring the tooth face into contact with the gauge blade. If the angle of clearance on the tooth is correct, it will correspond with the angle of the gauge blade. Cutter clearance gauges that have an adjustable gauge blade to check clearance angles of 0° to 30° are also available.

### Adjustable Parallel

The adjustable parallel in figure 1-16 consists of two wedges connected on their inclined surfaces by a sliding dovetail. An adjustable parallel can be locked at any height between its maximum and minimum limits. This instrument, constructed to about the same accuracy of dimensions as parallel blocks, is very useful to level and position setups in a milling machine or in a shaper vise. You should normally use an outside micrometer to set the adjustable parallel for height.

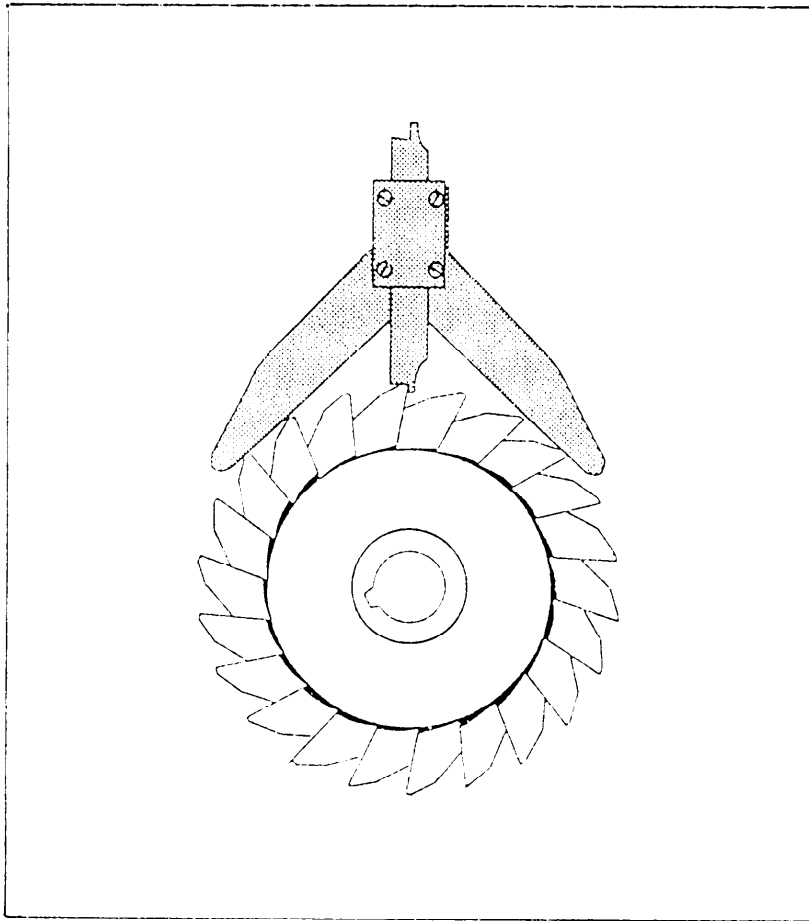


Figure 1-15.—Cutter clearance gauge.

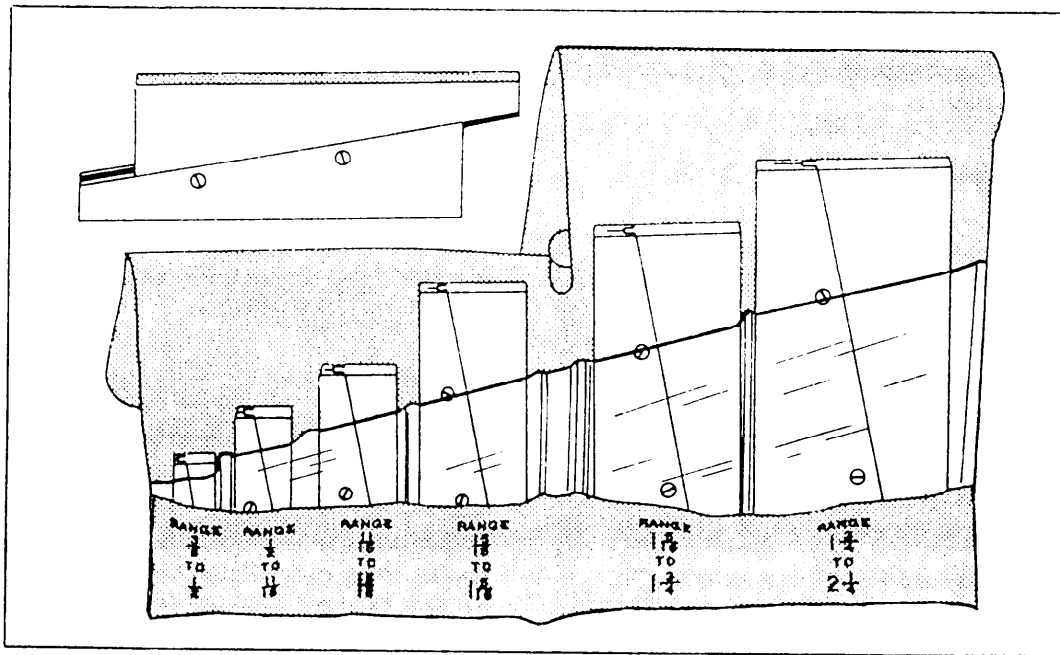


Figure 1-16.—Adjustable parallel.

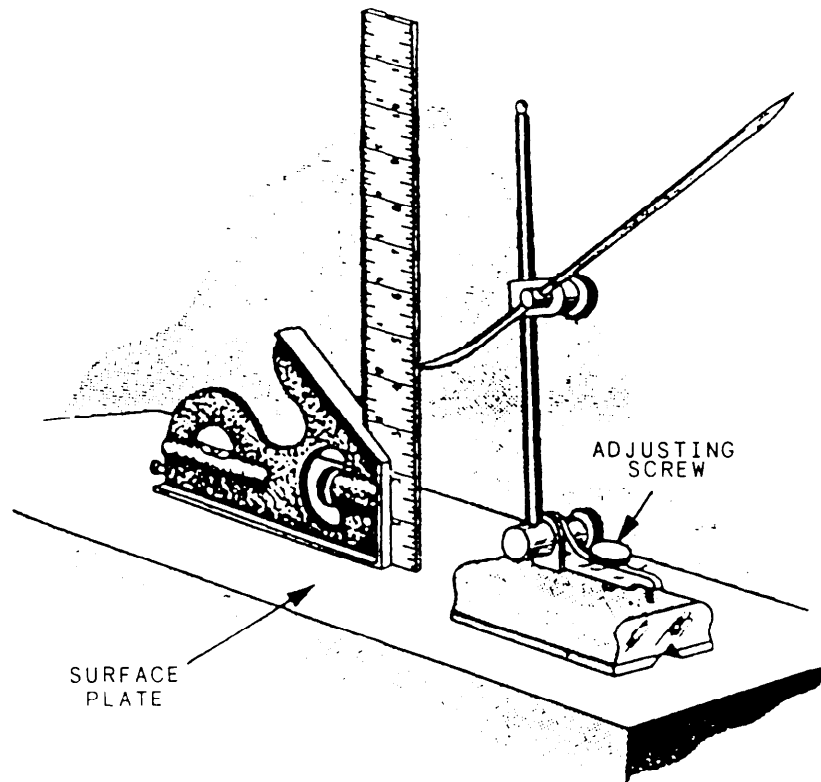


Figure 1-17.—Setting a dimension on a surface gauge.

## Surface Gauge

A surface gauge (fig. 1-17) is useful in gauging or measuring operations. It is used primarily in layout and alignment work and it is used with a scribe to transfer dimensions and layout lines. In some cases a dial indicator is used with the surface gauge to check trueness or alignment.

## FIXED GAUGES

Fixed gauges cannot be adjusted. Generally, they can be divided into two categories, graduated and nongraduated. The accuracy of your work, when you use fixed gauges, will depend on your ability to compare between the work and the gauge. For example, a skilled machinist can take a dimension accurately to within 0.005 of an inch or less using a common rule. Experience will increase your ability to take accurate measurements.

## Graduated Gauges

Graduated gauges are direct reading gauges that have scales inscribed on them, enabling you to take a reading while using the gauge. The gauges in this group are rules, scales, thread gauges, center gauges, feeler gauges, and radius gauges.

**RULES.**—The steel rule with holder set (fig. 1-18, view A) is convenient for measuring recesses. It has a long tubular handle with a split chuck for holding the ruled blade. The chuck can be adjusted by a knurled nut at the top of the holder, allowing the rule to be set at various angles. The set has rules ranging from 1/4 to 1 inch in length.

The angle rule (fig. 1-18, view B) is useful in measuring small work mounted between centers on a lathe. The long side of the rule (ungraduated) is placed even with one shoulder of the work. The graduated angle side of the rule can then be positioned easily over the work.

Another useful device is the keyseat rule (fig. 1-18, view C). It has a straightedge and a 6-inch machinist's-type rule arranged to form a right angle square. This rule and straightedge combination, when applied to the surface of a cylindrical workpiece, makes an excellent guide for drawing or scribing layout lines parallel to the axis of the work. This device is very convenient when making keyseat layouts on shafts.

You must take care of your rules if you expect them to give accurate measurements. Do not allow them to become battered, covered with rust, or



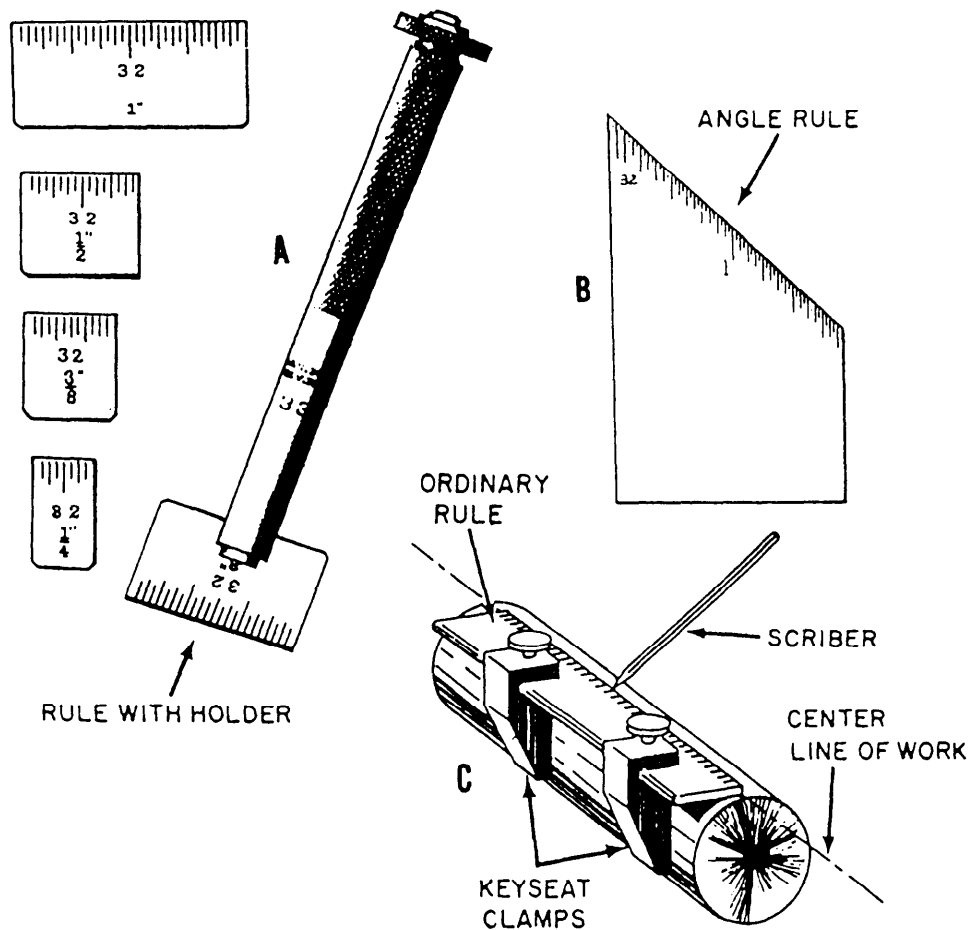


Figure 1-18.—Special rules for shop use.

otherwise damaged so that the markings cannot be read easily. Never use rules for scrapers. Once rules lose their sharp edges and square corners, their accuracy is decreased.

**SCALES.**—A scale is similar in appearance to a rule, since its surface is graduated into regular spaces. The graduations on a scale, however, differ from those on a rule because they are either larger or smaller than the measurements indicated. For example, a half-size scale is graduated so that 1 inch on the scale is equivalent to an actual measurement of 2 inches; a 12-inch long scale of this type is equivalent to 24 inches. A scale, therefore, gives proportional measurements instead of the actual measurements obtained with a rule. Like rules, scales are made of wood, plastic, or metal, and they generally range from 6 to 24 inches.

**ACME THREAD TOOL GAUGE.**—The thread gauge (fig. 1-19) is used to both grind the tool used to machine Acme threads and to set the tool up in the lathe. The sides of the Acme thread have an included

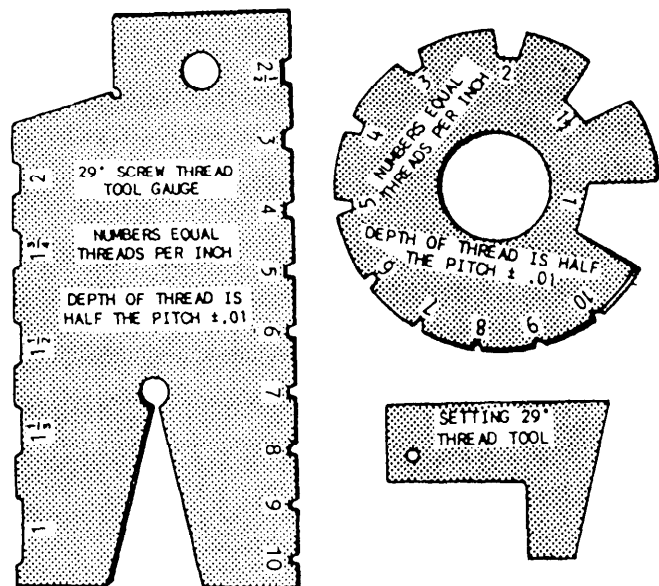


Figure 1-19.—Acme thread gauges.

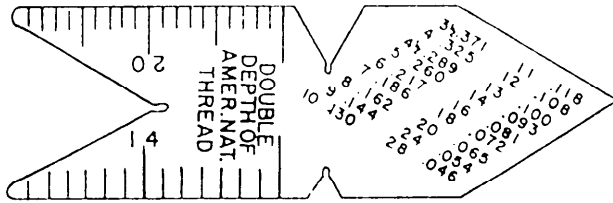


Figure 1-20.—Center gauge.

angle of  $29^\circ$  ( $14\frac{1}{2}^\circ$  to each side), and this is the angle made into the gauge. The width of the flat on the point of the tool varies according to the number of threads per inch. The gauge provides different slots for you to use as a guide when you grind the tool. It's easy to set up the tool in the lathe. First, make sure that the tool is centered on the work as far as height is concerned. Then, with the gauge edge laid parallel to the centerline of the work, adjust the side of your tool until it fits the angle on the gauge very closely.

**CENTER GAUGE.**—Use the center gauge (fig. 1-20) like the Acme thread gauge. Each notch and the point of the gauge has an included angle of  $60^\circ$ . Use the gauge primarily to check and to set the angle of the V-sharp and other  $60^\circ$  standard threading tools. You may also use it to check the lathe centers. The edges are graduated into  $1/4$ ,  $1/24$ ,  $1/32$ , and  $1/64$  inch for ease in determining the pitch of threads on screws.

**FEELER GAUGE.**—Use a feeler (thickness) gauge (fig. 1-21) to determine distances between two closely mating surfaces. When you use a combination of blades to get a desired gauge thickness, try to place the thinner blades between the heavier ones to protect the thinner blades and to prevent their kinking. Do not force blades into openings that are too small; the blades may bend and kink. To get the feel of using a

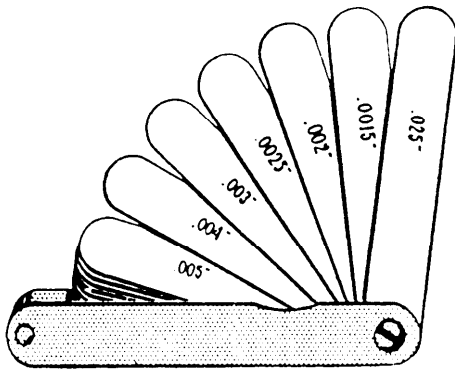


Figure 1-21.—Feeler (thickness) gauge.

feeler gauge, practice with it on openings of known dimensions.

**RADIUS GAUGE.**—The radius gauge (fig. 1-22) is often underrated in its usefulness to the machinist. Whenever possible, the design of most parts includes a radius located at the shoulder formed when a change is made in the diameter. This gives the part an added margin of strength at that particular place. When a square shoulder is machined in a place where a radius should have been, the possibility that the part will fail by bending or cracking is increased. The blades of most radius gauges have both concave (inside curve) and convex (outside curve) radii in the common sizes.

### Nongraduated Gauges

Nongraduated gauges are used primarily as standards, or to determine the accuracy of form or shape. They include the straightedge, machinist square, sine bar, parallel blocks, gauge blocks, ring and plug gauges, and thread-measuring wires. We'll explain the use of these gauges in the following paragraphs.

**STRAIGHTEDGES.**—Straightedges look very much like rules, except they are not graduated. They are used primarily to check surfaces for straightness; however, they can also be used as guides to help draw or scribe straight lines. Two types of straightedges are shown in figure 1-23. View A shows a straightedge made of steel that is hardened on the edges to prevent wear; it is the one you will probably use most often. The straightedge shown in view B has a knife edge and is used for work requiring extreme accuracy.

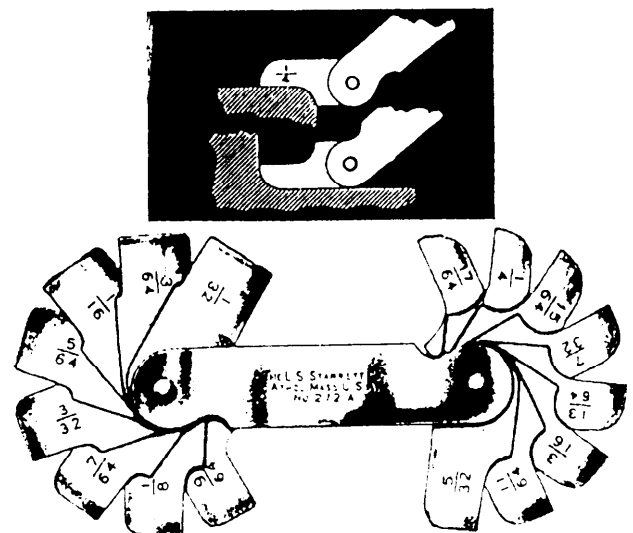


Figure 1-22.—Radius gauges.

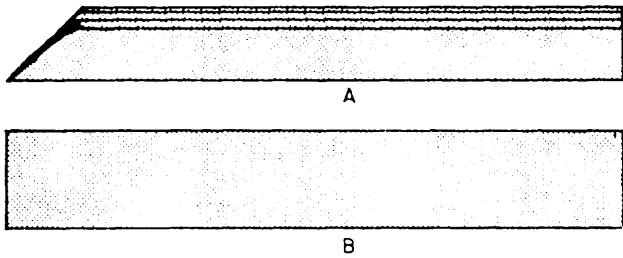


Figure 1-23.—Straightedge.

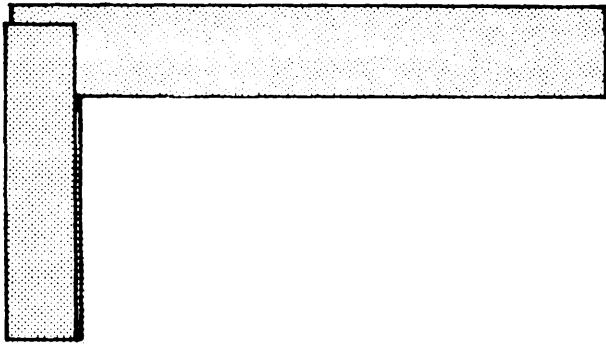


Figure 1-24.—Machinist's square.

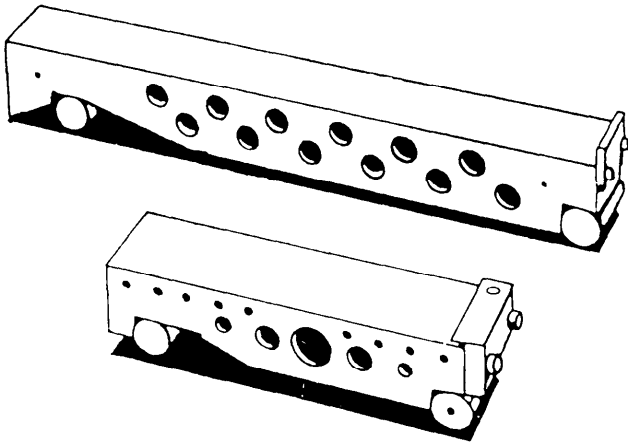


Figure 1-25.—Sine bars.

Always keep a straightedge in a box when it is not in use. Some straightedges are marked with two arrows, one near each end, which indicate balance points. When a box is not provided, place resting pads on a flat surface in a storage area where no damage to the straightedge will occur from other tools. Then, place the straightedge so the two balance points sit on the resting pads.

**MACHINIST'S SQUARE.**—The most common type of machinist's square has a hardened steel blade securely attached to a beam. The steel blade is NOT graduated. (See fig. 1-24.) This instrument is very useful in checking right angles and in setting up work on shapers, milling machines, and drilling machines. The size of machinist's squares ranges from 1 1/2 to 36 inches in blade length. You should take the same care of machinist's squares, in storage and use, as you do with a micrometer.

**SINE BAR.**—A sine bar (fig. 1-25) is a precision tool used to establish angles that require extremely close accuracy. When used in conjunction with a surface plate and gauge blocks, angles are accurate to 1 minute ( $1/60^\circ$ ). The sine bar is used to measure angles on work and to lay out an angle on work to be machined, or work may be mounted directly to the sine bar for machining. The cylindrical rolls and the parallel bar, which make up the sine bar, are all precision ground and accurately positioned to permit such close measurements. Be sure to repair any scratches, nicks, or other damage before you use the sine bar, and take care in using and storing the sine bar. Instructions on using the sine bar are included in chapter 2.

**PARALLEL BLOCKS.**—Parallel blocks (fig. 1-26) are hardened, ground steel bars that are used to lay out work or set up work for machining. The surfaces of the parallel block are all either parallel or perpendicular, as appropriate, and can be used to position work in a variety of setups with

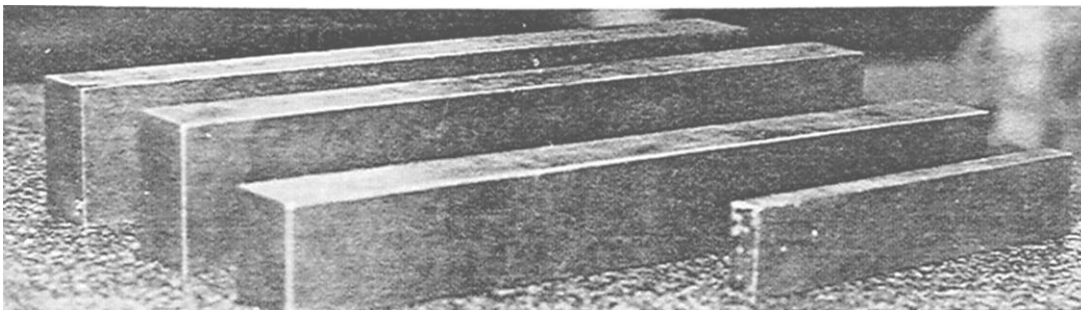


Figure 1-26.—Parallel blocks.

accuracy. They generally come in matched pairs and in standard fractional dimensions. Use care in storing and handling them to prevent damage. If it becomes necessary to grind the parallel blocks, be sure to change the size stamped on the ends of the blocks.

**GAUGE BLOCKS.**—Gauge blocks (not shown) are used as master gauges to set and check other gauges and instruments. Their accuracy is from two-millionths (0.000002) of an inch to eight-millionths (0.000008) of an inch, depending on the grade of the set. To visualize this minute amount, consider that the average thickness of a human hair divided 1,500 times equals 0.000002 inch. This degree of accuracy applies to the thickness of the gauge block, the parallelism of the sides, and the flatness of the surfaces. To attain this accuracy, a fine grade of hardenable alloy steel is ground and then lapped. The gauge blocks are so smooth and flat that when they are “wrung” or placed one atop the other you cannot separate them by pulling straight out. A set of gauge blocks has enough different size blocks that you can establish any measurement within the accuracy and range of the set. As you might expect, anything so accurate requires exceptional care to prevent damage and to ensure continued accuracy. A dust-free temperature-controlled atmosphere is preferred. After use, wipe each block clean of all marks and fingerprints, and coat it with a thin layer of white petrolatum to prevent rust.

**RING AND PLUG GAUGES.**—A ring gauge (fig. 1-27, views C and D) is a cylindrically-shaped disk that has a precisely ground bore. Ring gauges are used to check machined diameters by sliding the gauge over the surface. Straight, tapered, and threaded diameters can be checked by using the appropriate gauge. The ring gauge is also used to set other measuring instruments to the basic dimension required for their operation. Normally, ring gauges are available with a GO and a NOT GO size that represents the tolerance allowed for the particular size or job.

A plug gauge (fig. 1-27, views A and B) is used for the same types of jobs as a ring gauge. However, it is a solid shaft-shaped bar that has a precisely ground diameter used to check inside diameters or bores.

**THREAD MEASURING WIRES.**—These wires provide the most accurate method of measuring the fit or pitch diameter of threads, without going into the expensive and sophisticated optical and comparator equipment. The wires are accurately sized,

depending on the number of threads per inch. When they are laid over the threads in a position that allows an outside micrometer to measure the distance between them, the pitch diameter of the threads can be determined. Sets are available that contain all the more common sizes. Detailed information on computing and using the wire method for measuring is covered in chapter 6.

## CARE AND MAINTENANCE OF MEASURING INSTRUMENTS

The proper care and maintenance of precision instruments is very important to a conscientious MR. To help you maintain your instruments in the most accurate and reliable condition possible, the Navy has established a calibration program. It provides calibration technicians with the required standards and procedures, and a schedule of how often an instrument must be calibrated to be reliable. When an instrument is calibrated, a sticker is affixed to it showing the date the calibration was done and the date the next calibration is due. Whenever possible, you should use the Navy calibration program to verify the accuracy of your instruments. Some repair jobs, due to their sensitive nature, demand the reliability provided by the program. Information concerning the procedures that you can use in the shop to check the accuracy of an instrument is contained in the following paragraphs.

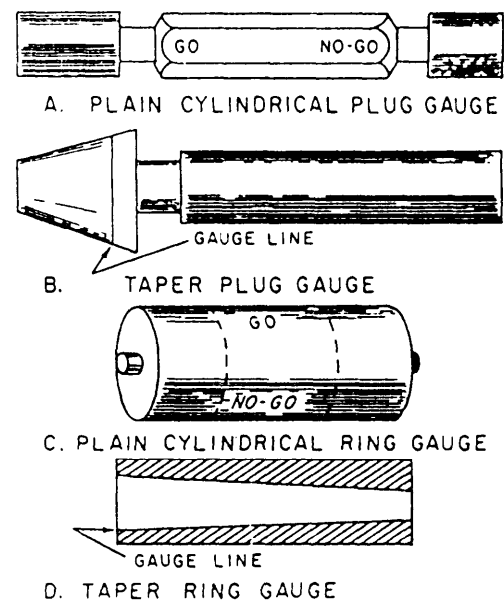


Figure 1-27.—Ring gauges and plug gauges.

## MICROMETERS

The micrometer is one of the most used, and often one of the most abused, precision measuring instruments in the shop. Careful observation of the do's and don'ts in the following list will enable you to take proper care of the micrometer you use:

- Always stop the work before taking a measurement. Do NOT measure moving parts because the micrometer may get caught in the rotating work and be severely damaged.

- Always open a micrometer by holding the frame with one hand and turning the knurled sleeve with the other hand. Never open a micrometer by twirling the frame, because such practice will put unnecessary strain on the instrument and cause excessive wear of the threads.

- Apply only moderate force to the knurled thimble when you take a measurement. Always use the friction slip ratchet if there is one on the instrument. Too much pressure on the knurled sleeve will not only result in an inaccurate reading, but may also cause the frame to spring, forcing the measuring surfaces out of line.

- When a micrometer is not in actual use, place it where it is not likely to be dropped. Dropping a micrometer can cause the frame to spring; if dropped, the instrument should be checked for accuracy before any further readings are taken.

- Before a micrometer is returned to stowage, back the spindle away from the anvil, wipe all exterior surfaces with a clean, soft cloth, and coat the surfaces with a light oil. Do not reset the measuring surfaces to close contact because the protecting film of oil in these surfaces will be squeezed out.

- A micrometer caliper should be checked for zero setting (and adjusted when necessary) as a matter of routine to ensure that reliable readings are being obtained. To do this, proceed as follows:

1. Wipe the measuring faces, making sure that they are perfectly clean, and then bring the spindle into contact with the anvil. Use the same moderate force that you ordinarily use when taking a measurement. The reading should be zero; if it is not, the micrometer needs further checking.

2. If the reading is more than zero, examine the edges of the measuring faces for burrs. Should burrs be present, remove them with a small slip of

oilstone; clean the measuring surfaces again, and then recheck the micrometer for zero setting.

3. If the reading is less than zero, or if you do not obtain a zero reading after making the correction described in step 2, you will need to adjust the spindle-thimble relationship. The method for setting zero differs considerably between makes of micrometers. Some makes have a thimble cap that locks the thimble to the spindle; some have a special rotatable sleeve on the barrel that can be unlocked; and some have an adjustable anvil.

- To make adjustments to micrometers follow these steps:

1. To adjust the THIMBLE-CAP TYPE, back the spindle away from the anvil, release the thimble cap with the small spanner wrench provided for that purpose, and bring the spindle into contact with the anvil. Hold the spindle firmly with one hand and rotate the thimble to zero with the other; after zero relation has been established, rotate the spindle counterclockwise to open the micrometer, and then tighten the thimble cap. After tightening the cap, check the zero setting again to be sure the thimble-spindle relation was not disturbed while the cap was being tightened.

2. To adjust the ROTATABLE SLEEVE TYPE, unlock the barrel sleeve with the small spanner wrench provided for that purpose, bring the spindle into contact with the anvil, and rotate the sleeve into alignment with the zero mark on the thimble. After completing the alignment, back the spindle away from the anvil, and retighten the barrel sleeve locking nut. Recheck for zero setting, to be sure you did not disturb the thimble-sleeve relationship while tightening the lock nut.

3. To set zero on the ADJUSTABLE ANVIL TYPE, bring the thimble to zero reading, lock the spindle if a spindle lock is provided, and loosen the anvil lock screw. After you have loosened the lock screw, bring the anvil into contact with the spindle, making sure the thimble is still set on zero. Tighten the anvil setscrew lock nut slightly, unlock the spindle, and back the spindle away from the anvil; then lock the anvil setscrew firmly. After locking the setscrew, check the micrometer for zero setting to make sure you did not move the anvil out of position while you tightened the setscrew.

1 The zero check and methods of adjustment of course apply directly to micrometers that will measure to zero; the PROCEDURE FOR LARGER

MICROMETERS is essentially the same except that a standard must be placed between the anvil and the spindle to get a zero measuring reference. For example, a 2-inch micrometer is furnished with a 1-inch standard. To check for zero setting, place the standard between the spindle and the anvil and measure the standard. If zero is not indicated, the micrometer needs adjusting.

- Inside micrometers can be checked for zero setting and adjusted in about the same way as a micrometer caliper; the main difference in the method of testing is that an accurate micrometer caliper is required for transferring readings to and from the standard when an inside micrometer is being checked.

- Micrometers of all types should be disassembled periodically for cleaning and lubrication of internal parts. When this is done, each part should be cleaned in noncorrosive solvent, completely dried, and then given a lubricating coat of watchmaker's oil or a similar light oil.

## VERNIER GAUGES

Vernier gauges also require careful handling and proper maintenance if they are to remain accurate. The following instructions apply to vernier gauges in general:

- Always loosen a gauge into position. Forcing, besides causing an inaccurate reading, is likely to force the arms out of alignment.

- When taking a measurement, use only gentle pressure on the fine adjustment screw. Heavy pressure will force the two scales out of parallel.

- Before putting a vernier gauge away, wipe it clean and give it a light coating of oil. (Perspiration from hands will cause the instrument to corrode rapidly.)

## Dials

Dial indicators and other instruments that have a mechanically operated dial as part of their measurement features are easily damaged by misuse and lack of proper maintenance. The following instructions apply to dials in general:

- As previously mentioned, be sure the dial you have selected to use has the range capability required. When a dial is extended beyond its design limit, some lever, small gear, or rack must give to the pressure. The dial will be rendered useless if this happens.

- Never leave a dial in contact with any surface that is being subjected to a shock (such as hammering a part when dialing it in) or an erratic and uncontrolled movement that could cause the dial to be overtraveled.

- Protect the dial when it is not being used. Provide a storage area where the dial will not receive accidental blows and where dust, oil, and chips will not contact it.

- When a dial becomes sticky or sluggish in operating, it may be either damaged or dirty. You may find that the pointer is rubbing the dial crystal or that it is bent and rubbing the dial face. Never oil a sluggish dial. Oil will compound the problems. Use a suitable cleaning solvent to remove all dirt and residue.

## CHAPTER 2

# LAYOUT AND BENCHWORK

### CHAPTER LEARNING OBJECTIVES

*Upon completing this chapter, you should be able to do the following:*

- *Describe the process used to extract data from blueprints.*
- *Describe the procedures used to draft working drawings for parts manufacture and alteration.*
- *Explain surface characteristics of metal.*
- *Explain how to determine surface finish quality.*
- *Explain layout work.*
- *Explain the procedure used to lay out valve flange bolt holes.*
- *State the process used to hand scrape and blue parts and surfaces for flatness and fit.*
- *Explain filing operation.*
- *Explain the setup and operation of pressure.*
- *Explain the setup and operation of oxyacetylene equipment.*
- *Explain the use of helicoils.*

As an MR, you will repair or help repair many types of equipment used on ships. You will make replacement parts, disassemble and assemble equipment, make layouts of parts to be machined, and do precision work to fit mating parts of equipment. This is known as benchwork and it includes practically all repair work other than actual machining.

This chapter contains information that you need to make effective repairs. *Read Blueprint Reading and Sketching*, NAVEDTRA 10077-F1, for additional information on working drawings. Other sources of information that you should study for details on specific equipment include the *Naval Ships' Technical Manual*, the manufacturers technical manuals, and the training manuals for the equipment you are working on.

As with any shop equipment you must observe all posted safety precautions. Review your equipment operators manual for safety precautions and any chapters of *Navy Occupational Safety and Health (NAVOSH) Program Manual for Forces Afloat (OPNAV) Instruction 5100.19B* that pertain to the equipment.

### LIMITS OF ACCURACY

You must work within the limits of accuracy specified on the drawing. A clear understanding of TOLERANCE and ALLOWANCE will help you to avoid small, but potentially dangerous, errors. These terms may seem closely related, but each has a very precise meaning and application. We'll point out the

meanings of these terms and the importance of observing the distinction between them.

## TOLERANCE

In most instances it's impractical and unnecessary to work to the absolute or exact basic dimension. The designer calculates, in addition to the basic dimensions, an allowable variation. The amount of variation, or limit of error permissible, is indicated on the drawing as plus or minus (+) a given amount, such as  $\pm 0.005$  or  $\pm 1/64$ . The difference between the allowable minimum and the allowance maximum dimension is tolerance. For example, in figure 2-1:

Basic dimension = 4

Long limit =  $4 \frac{1}{64}$

Short limit =  $3 \frac{63}{64}$

Tolerance =  $1/32$

When tolerances are not actually specified on a drawing, you can make fairly concrete assumptions concerning the accuracy expected, by using the following principles. For dimensions that end in a fraction of an inch, such as  $1/8$ ,  $1/16$ ,  $1/32$ ,  $1/64$ , the expected accuracy is  $\pm 1/64$  inch. When the dimension is given in decimal form, the following applies:

If a dimension is given as 3.000 inches, the accuracy expected is  $\pm 0.0005$  inch; or if the dimension is given as 3.00 inches, the accuracy expected is  $\pm 0.005$  inch. The  $+0.0005$  is called in shop terms, "plus or minus five ten-thousandths of an inch." The  $\pm 0.005$  is called "plus or minus five thousandths of an inch."

## ALLOWANCE

Allowance is an intentional difference planned in dimensions of mating parts to provide the desired fit. A CLEARANCE ALLOWANCE permits movement between mating parts when they are assembled. For example, when a hole with a 0.250-inch diameter is fitted with a shaft that has a 0.245-inch diameter, the clearance allowance is 0.005 inch. An INTERFERENCE ALLOWANCE is the opposite of a clearance allowance. The difference in dimensions in this case provides a tight fit. You would need force to assemble parts that have an interference allowance. If a shaft with a 0.251-inch diameter is fitted into the hole identified in the preceding example, the difference between the dimensions will give an

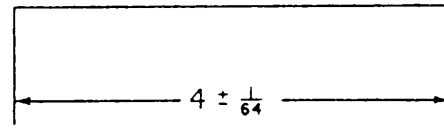


Figure 2-1.—Basic dimension and tolerance.

interference allowance of 0.001 inch. As the shaft is larger than the hole, force is necessary to assemble the parts.

What is the relationship between tolerance and allowance? When you manufacture mating parts, you must control the tolerance of each part so the parts will have the proper allowance when they are assembled. Here's an example. A hole 0.250 inch in diameter with a tolerance of 0.005 inch ( $\pm 0.0025$ ) is prescribed for a job. The shaft to be fitted in the hole is to have a clearance allowance of 0.001 inch. You must finish the hole within the limits and determine the required size of the shaft exactly before you can make the shaft. If you finish the hole to the upper limit of the basic dimension (0.2525 inch), you would machine the shaft to 0.2515 inch or 0.001 inch smaller than the hole. If the dimension of the shaft was given with the same tolerance as the hole there would be no control over the allowance between the parts. As much as 0.005-inch allowance (either clearance or interference) could result.

To retain the required allowance and still permit some tolerance in the dimensions of the mating parts, the tolerance is limited to one direction on each part. This single direction (unilateral) tolerance stems from the basic hole system. If a clearance allowance is required between mating parts, the hole may be larger but not smaller than the basic dimension; the part that fits into the opening may be smaller but not larger than the basic dimension. Thus, shafts and other parts that fit into a mating opening have a minus tolerance only, while the openings have a plus tolerance only. If an interference allowance between the mating parts is required, the situation is reversed; the opening can be smaller but not larger than the basic dimension, while the shaft can be larger but not smaller than the basic dimension. Therefore, you can expect to see a tolerance such as  $+0.005$ ,  $-0$ , or  $+0$ ,  $-0.005$ , but with the required value not necessarily 0.005. You can get a better understanding of a clearance allowance, or an interference allowance, if you make a rough sketch of the piece and add dimensions to the sketch where they apply.



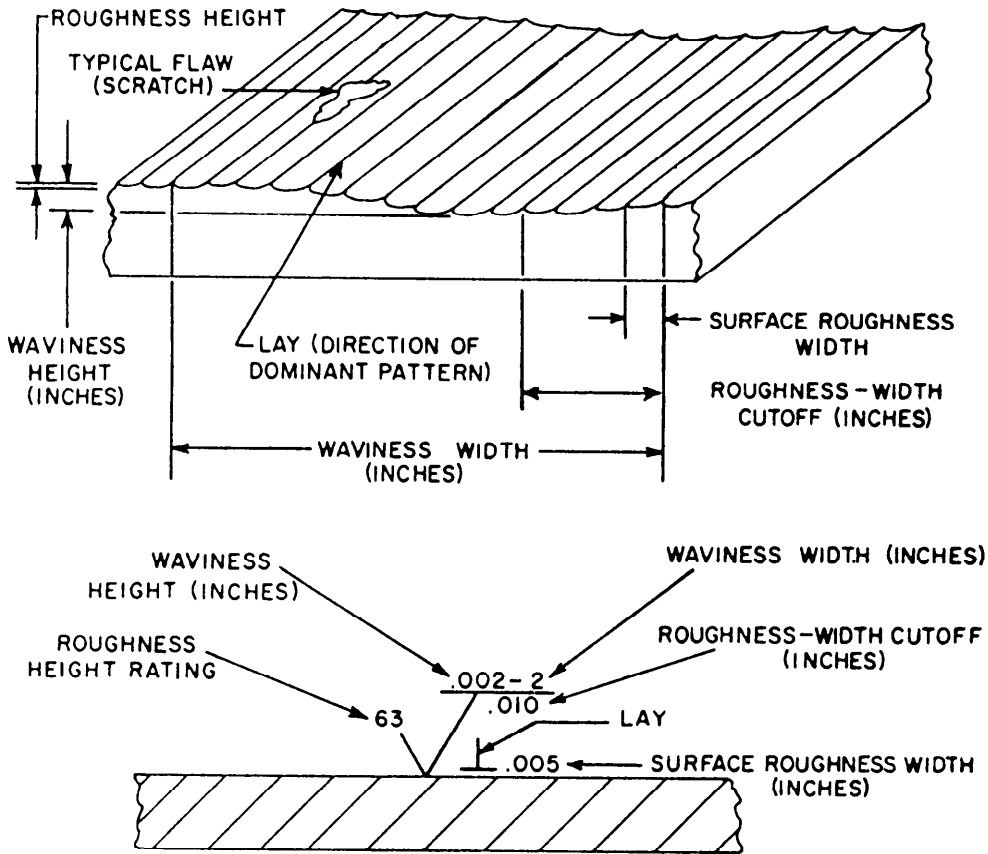


Figure 2-2.—Relation of symbols to surface characteristics.

## SURFACE CHARACTERISTICS OF METAL

While you must control the finished dimensions of a part, you also must consider the degree of smoothness, or surface roughness. Both are very important in the efficiency and life of a machine part.

A finished surface may appear to be perfectly flat; but, when you examine it with surface finish measuring instruments, you will find it is formed of irregular waves. On top of these waves are other smaller waves that we'll call peaks and valleys. You'll measure these peaks and valleys to determine the surface roughness measurements of height and width. Measure the larger waves to give the waviness height and width measurements. Figure 2-2 illustrates the general location of the various areas for surface finish measurements and the relation of the symbols to the surface characteristics.

Surface roughness is the measurement of the finely spaced surface irregularities; their height, width, direction, and shape establish the predominant surface pattern. The irregularities are caused by the cutting or abrading action of the machine tools that have been used to obtain the surface. The basic

roughness symbol that you'll find on the drawing is a check mark. This symbol is supplemented with a horizontal extension line above it when requirements such as waviness width or contact area must be specified in the symbol. A drawing that shows only the basic symbol indicates that the surface finish requirements are detailed in the NOTES block. The roughness height rating is placed at the top of the short leg of the check (view A, fig. 2-3). If only one

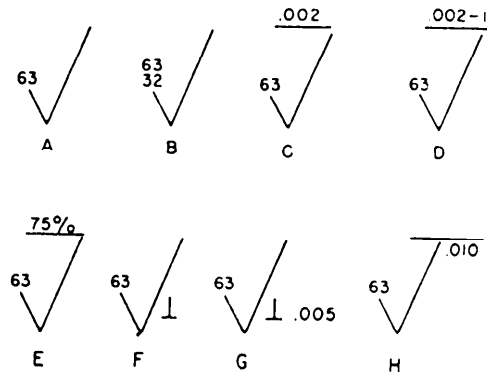


Figure 2-3.—Symbols used to indicate surface roughness, waviness, and lay.


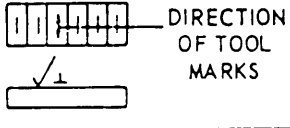

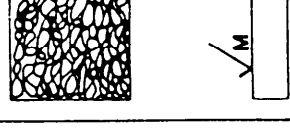

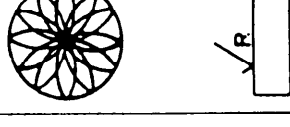
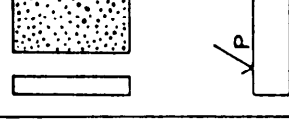
number is shown for roughness height, it is the maximum permissible roughness height rating; if two are shown, the top number is the maximum (view B, fig. 2-3). A point to remember is that the smaller the number in the roughness height rating, the smoother the surface.

Waviness height values are shown directly above the extension line at the top of the long leg of the basic check (view C, fig. 2-3). Waviness width values are placed to the right of the waviness height values (view D, fig. 2-3). Where minimum requirements for contact or bearing surfaces must be shown, the percentage is placed at the top of the long leg of the

basic check (view E, fig. 2-3). The NOTES block of the drawing will show any further surface finish requirements, such as waviness width or height.

Lay is the direction of the predominant surface pattern produced by the tool marks. The symbol indicating lay is placed to the right and slightly above the point of the surface roughness symbol, as shown in view F of figure 2-3. (Fig. 2-4 shows the seven symbols that indicate the direction of lay.)

The roughness width value is shown to the right of and parallel to the lay symbol. The roughness width cutoff is placed immediately below the extension line and to the right of the long leg of the

LAY SYMBOL	DESIGNATION	EXAMPLE
	LAY PARALLEL TO THE BOUNDARY LINE REPRESENTING THE SURFACE TO WHICH THE SYMBOL APPLIES.	
⊥	LAY PERPENDICULAR TO THE BOUNDARY LINE REPRESENTING THE SURFACE TO WHICH THE SYMBOL APPLIES.	
X	LAY ANGULAR IN BOTH DIRECTIONS TO BOUNDARY LINE REPRESENTING THE SURFACE TO WHICH SYMBOL APPLIES.	
M	LAY MULTIDIRECTIONAL	
C	LAY APPROXIMATELY CIRCULAR RELATIVE TO THE CENTER OF THE SURFACE TO WHICH THE SYMBOL APPLIES.	
R	LAY APPROXIMATELY RADIAL RELATIVE TO THE CENTER OF THE SURFACE TO WHICH THE SYMBOL APPLIES.	
P <sup>3</sup>	LAY PARTICULATE, NON-DIRECTIONAL, OR PROTUBERANT	

<sup>3</sup> The "P" symbol is not currently shown in ISO Standards. American National Standards Committee B46 (Surface Texture) has proposed its inclusion in ISO 1302—"Methods of Indicating surface texture on drawings."

Figure 2-4.—Symbols indicating the direction of lay.

MACHINE OPERATION	ROUGHNESS HEIGHT (MICROINCHES)										
	2000	1000	500	250	125	63	32	16	8	4	2
FLAME CUTTING		█									
SAWING		█	█	█	█	█					
PLANING		█	█	█	█	█					
DRILLING				█	█	█					
MILLING				█	█	█	█				
BROACHING					█	█	█				
REAMING					█	█	█				
BORING, TURNING				█	█	█	█	█			
ROLLER BURNISHING								█	█		
GRINDING							█	█	█	█	
HONING							█	█	█	█	█
POLISHING								█	█	█	█
LAPPING								█	█	█	█
SAND CASTING		█									

Figure 2-5.—Roughness height values for machine operations.

basic check mark. These symbols for roughness width are shown in view G and H of figure 2-3.

Figure 2-5 shows a sampling of some roughness height values that can be obtained by the different machine operations.

### READING SURFACE FINISH QUALITY

A surface finish is seldom flat. We said earlier that close examination with surface finish measuring instruments shows the surface to be formed of irregular waves. On top of the waves are other smaller irregularities known as peaks and valleys. We will now discuss several ways to evaluate surface finish.

### VISUAL INSPECTION

There are occasions when visual comparison with the naked eye will show that one surface is rougher than the other. This is possible only in cases of widely differing surfaces. You also can use visual inspection to detect large cracks in metal.

You can make a visual comparison with illuminated magnifiers (fig. 2-6).

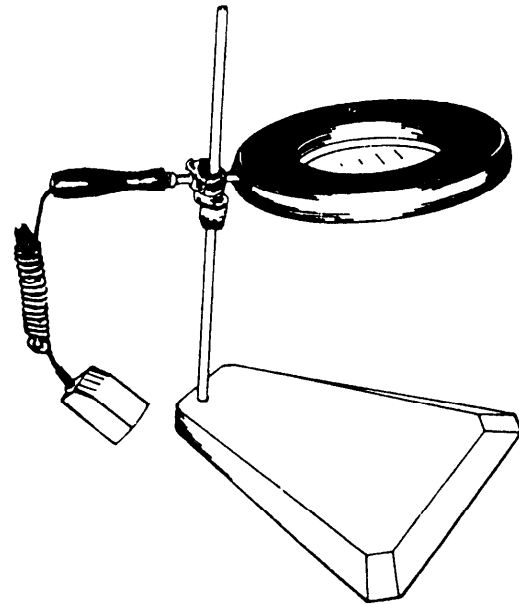


Figure 2-6.—Magnifier with illuminator for surface inspection.

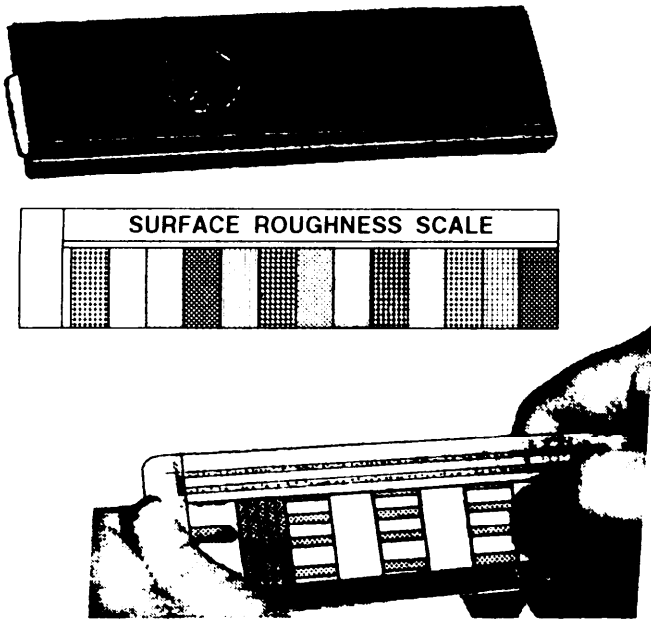


Figure 2-7.—Master roughness scales.

## TOUCH COMPARISON

Move a fingernail along the surface of the job and make a mental note of the amount of resistance and the depth of irregularities. Then, move your fingernail across a series of master roughness scales that have numbers corresponding to their measurement in microinches (fig. 2-7). The machine finish must compare satisfactorily with the correct master.

## INTERFERENCE MICROSCOPE INSPECTION

This inspection requires you to use a microscope with an optical flat plate and a monochromatic light (fig. 2-8). The microscope allows you to see the height of the surface irregularity in light reflected between the microscope objective and surface of the work. The interference fringes indicate the intersection of the wave fronts reflected between the work and the front surface of the microscope objective. The distance between the fringes represents 11 microinches (11 millionths of an inch). The interference microscope is used primarily in laboratories, but you should be aware of it in case you encounter it during your career.

## PROFILOMETER

The profilometer (fig. 2-9) is the instrument most commonly used to find the degree of surface

roughness. It uses the tracer method and actually measures the differences in the depth of the surface irregularity.

The two main units of the profilometer are the tracer and the amplimeter. Tracers are made in several designs to measure a variety of shapes. The tracer has a stylus with a very small radius at its tip. As the tracer is moved across the surface being measured, the stylus follows the contours of the irregularities left by the machining operation. The up and down movements of the tracer stylus are converted into a small fluctuating voltage. The voltage is fed into the amplimeter where it is amplified to actuate the microinches meter on the front panel (fig. 2-10). The meter shows the variations in the average roughness height in microinches.

A motor-driven unit, the motorace (fig. 2-9), provides mechanical movement of the tracer and its stylus when manual operation is not practical.

You don't need technical knowledge or special skill to operate instruments that are used to check for surface roughness. You can set up the instrument on a bench or cabinet beside the production machine and

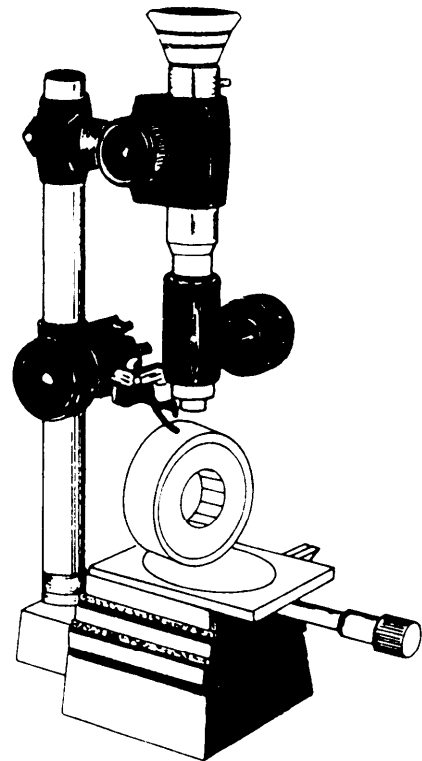


Figure 2-8.—The interference (surface-finish) microscope.

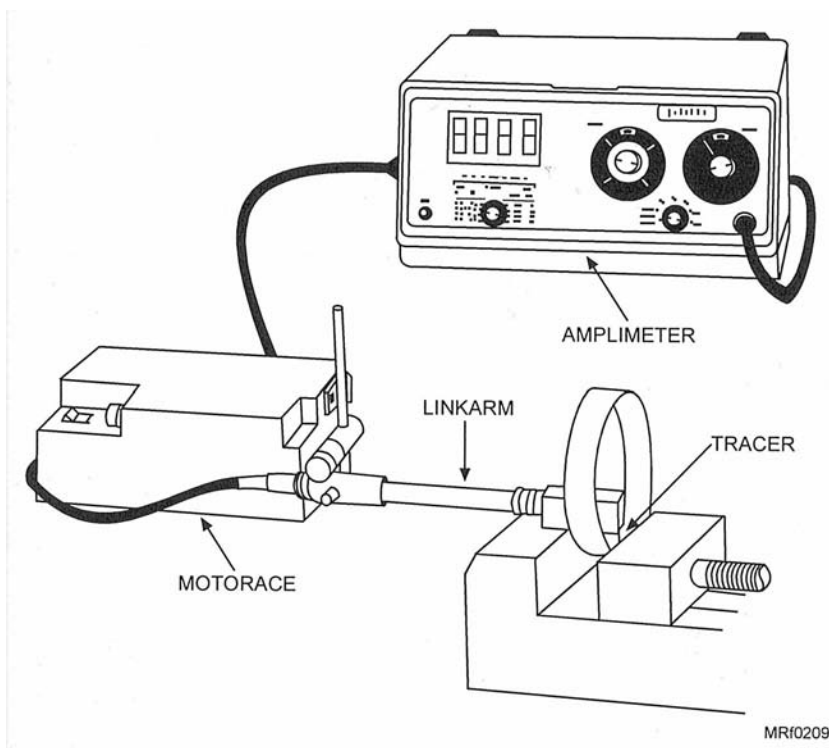


Figure 2-9.—The profilometer measuring the surface roughness of an internal diameter.

Deleted—No permission granted for electronic copy.

Figure 2-10.—The profilometer amplifier control panel.

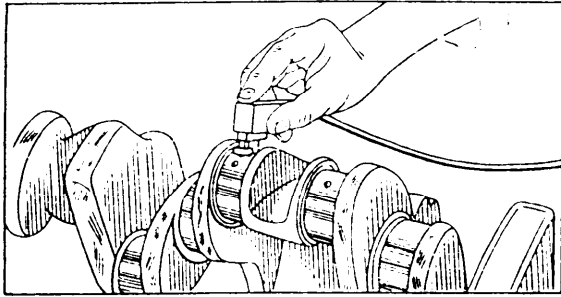


Figure 2-11.—Checking surface finish on the machine.

check the workpiece manually while it is in the machine (fig. 2-11).

## SURFACE ANALYZER

The surface analyzer (fig. 2-12) is a practical shop instrument designed for the accurate measurement of surface finish roughness. Like the profilometer, it measures the irregularities of the surface finish and records them in microinches. This is done by a tracer stylus, which registers the rise and fall of the peaks and valleys on the finished surfaces. These variations are amplified and indicated on the electrical meter, calibrated to read in microinches.

## LAYOUT METHODS

*Layout* is the term used to describe the marking of metal surfaces to provide an outline for machining. A layout is comparable to a single view (end, top, or side) of a part that is sketched directly on the workpiece. The degree of difficulty depends on the intricacies of the part to be laid out and the number of operations required to make the part. A flange layout, for example, is relatively simple as the entire layout can be made on one surface of the blank flange. However, an intricate casting may require layout lines on more than one surface. This requires careful study and concentration to make sure the layout will have the same relationships as those shown on the drawing (or sample) that you are using.

When a part must be laid out on two or more surfaces, you may need to lay out one surface and machine it to size before using further layout lines. This prevents removal of layout lines on one surface while you are machining another.

The process of computing and transferring dimensions will help you become familiar with the

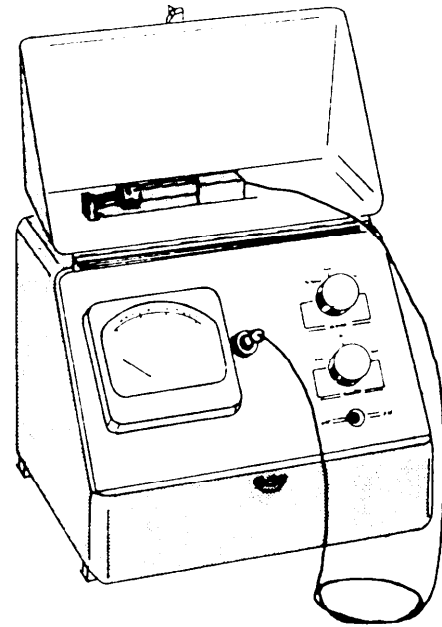


Figure 2-12.—Surface analyzer.

relationship of the surfaces. That understanding will help you plan the sequence of machining operations.

Mechanical drawing and layout are closely related subjects; knowledge of one will help you understand the other. You also must know general mathematics, trigonometry, and geometry, and how to select and use tools for jobs related to layout and mechanical drawing. Study *Mathematics*, Volume I, NAVEDTRA 10069-D1; *Mathematics*, Volume 2-A, NAVEDTRA 10062; *Use and Care of Hand Tools and Measuring Tools*, NAVEDTRA 12085, and *Blueprint Reading and Sketching*, NAVEDTRA 10077-F7, for additional information.

The following information applies to practically all layouts. Layout lines are formed by using a reference edge or point on the stock or by using the surface plate as a base. Study carefully the section on geometric construction. It will help you make layouts when you can't use a reference edge of the stock or a surface plate mounting of the stock.

## LINES SQUARE OR PARALLEL TO EDGES

When scribing layout lines on sheet metal, hold the scratch awl, or scribe, as shown in figure 2-13. Lean it toward the direction in which it will be moved and away from the straightedge. This will help you scribe a smooth line that will follow the edge of the

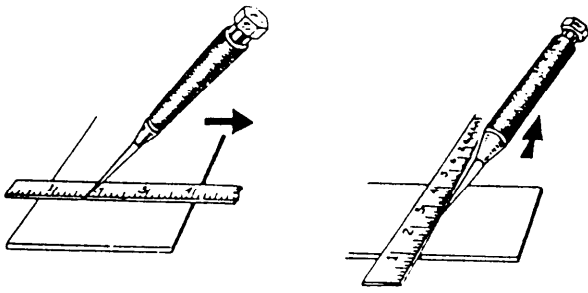


Figure 2-13.—Using a scribe.

straightedge, template, or pattern at its point of contact with the surface of the metal.

To scribe a line on stock with a combination square, place the squaring head on the edge of the stock, as shown in figure 2-14. Draw the line along either edge of the blade. The line will be square with the edge of the stock against which the squaring head is held; that is, the angle between the line and the edge will be  $90^\circ$ .

To draw lines parallel to an edge using a combination square, extend the blade from the squaring head the required distance, such as the 2-inch setting shown in figure 2-15. Secure the blade at this position. Scribe a line parallel to the edge of the stock by holding the scratch awl, or scribe, at the end of the blade as you move the square along the edge. All lines so scribed, with different blade settings, will be parallel to the edge of the stock and parallel to each other.

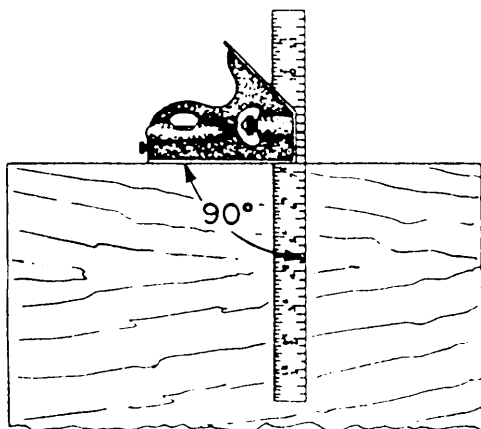


Figure 2-14.—Using the combination square.

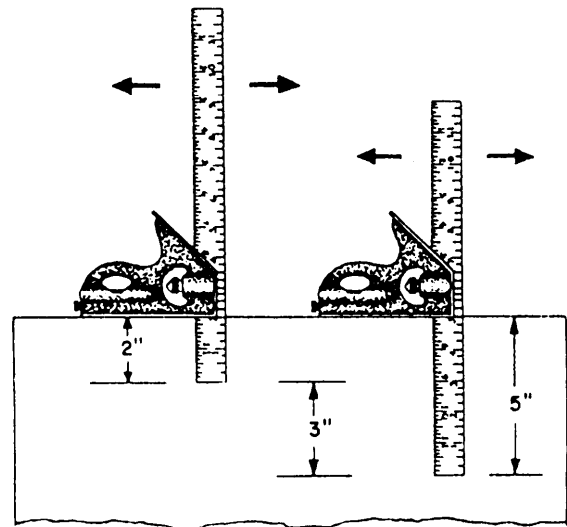


Figure 2-15.—Laying out parallel lines with a combination square.

To scribe a line parallel to an edge with a hermaphrodite caliper, hold the caliper, as shown in figure 2-16, so the curved leg maintains contact with the edge while the other leg scribes the line. Hold the caliper so the line will be scribed at the desired distance from the edge of the stock.

## FORMING ANGULAR LINES

To lay out a 45-degree angle on stock with a combination square, place the squaring head on the

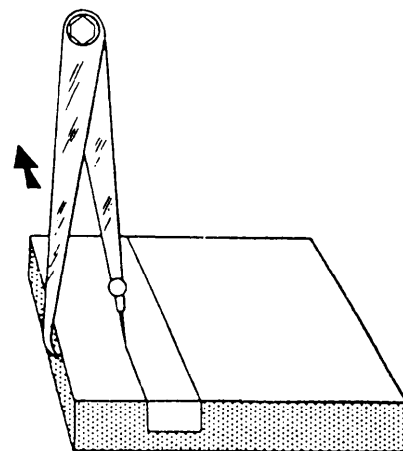


Figure 2-16.—Laying out a parallel line with a hermaphrodite caliper.

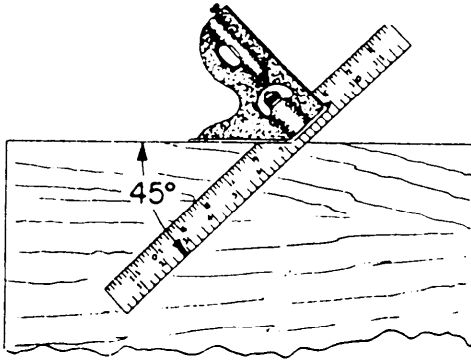


Figure 2-17.—Laying out a 45-degree angle.

edge of the stock, as shown in figure 2-17. Draw the line along either edge of the blade. The line will form a 45-degree angle with the edge of the stock against which the squaring head is held.

To draw angular lines with the protractor head of a combination square, loosen the adjusting screw and rotate the blade so the desired angle lines up with the index mark on the body of the protractor head. The setting shown in figure 2-18 is 60°. Tighten the screw to hold the setting.

Hold the body of the protractor head in contact with the true edge of the work with the blade resting on the surface. Scribe the lines along the edge of the blade on the surface of the work. The angle set on the scale determines the angle laid out on the work. All

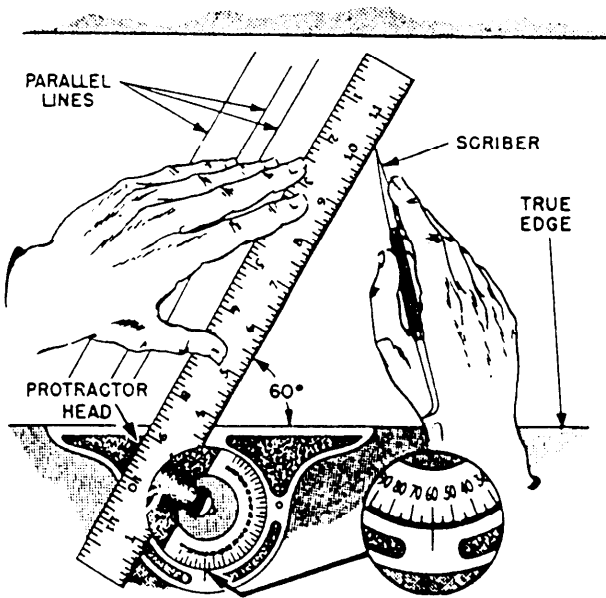


Figure 2-18.—Laying out angular lines.

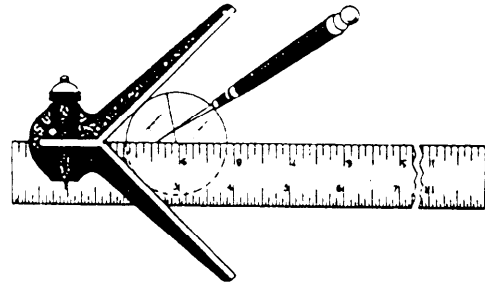


Figure 2-19.—Locating the center of round stock.

lines drawn with the same setting, and from the same true edge of the work, will be parallel lines.

Use the center head and rule, as illustrated in figure 2-19, to locate the center of round stock. To find the center of square and rectangular shapes, scribe straight lines from opposite corners of the workpiece. The intersection of the lines locates the center.

### LAYING OUT CIRCLES AND IRREGULAR LINES

Circles or segments of circles are laid out from a center point. To ensure accuracy, prick-punch the center point to keep the point of the dividers from slipping out of position.

To lay out a circle with a divider, take the setting of the desired radius from the rule, as shown in figure 2-20. Note that the 3-inch setting is being taken AWAY from the end of the rule. This reduces the chance of error as each point of the dividers can be

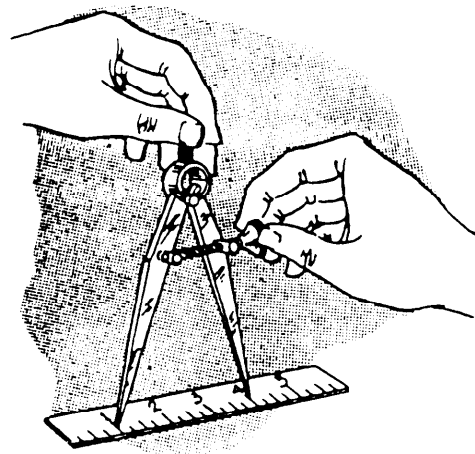


Figure 2-20.—Setting a divider to a dimension.



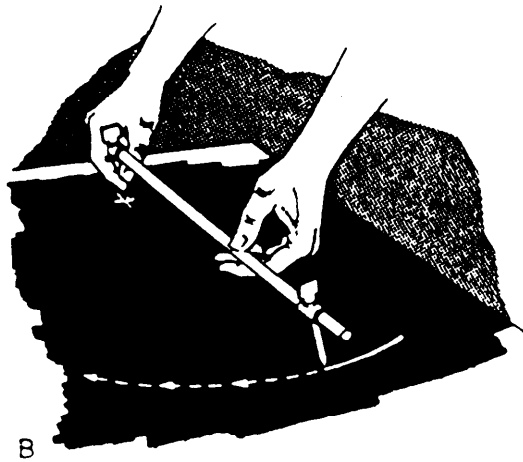
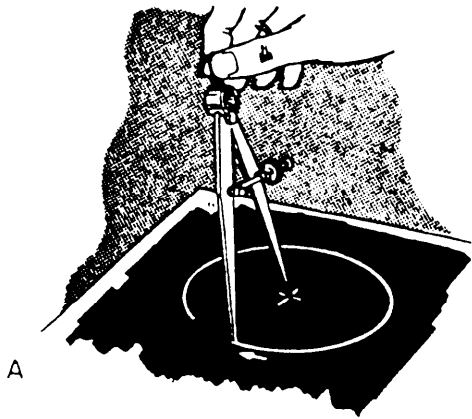


Figure 2-21.—Laying out circles.

set on a graduation. Place one leg of the divider at the center of the proposed circle. Then, lean the tool in the direction it will be rotated and rotate it by rolling the knurled handle between your thumb and index finger (view A of fig. 2-21).

When setting trammel points, shown in view B of figure 2-21, follow the same directions as for a divider. You may need a steel tape to set the trammel points.

To lay out a circle with trammel points, hold one point at the center and lean the tool in the direction you plan to move the other point. Then, swing the arc, or circle, as shown in view B of figure 2-21.

To transfer a distance measurement with trammel points, hold one point as you would to lay out a circle. Then, swing a small arc with the other point opened to the desired distance.

Scribing an irregular line to a surface is a skill used to fit a piece of stock to a curved surface, as shown in figure 2-22. In view A you see the complete

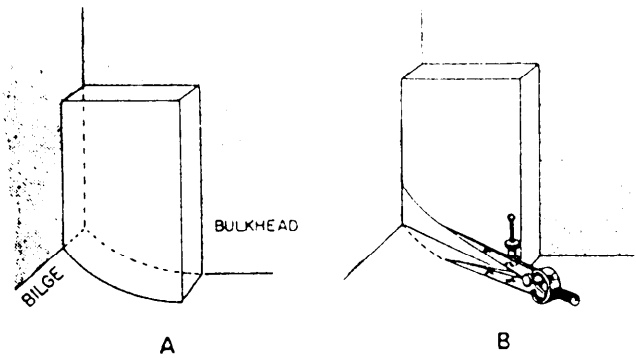


Figure 2-22.—Laying out an irregular line from a surface.

fit. In view B the divider has scribed a line from left to right. When scribing horizontal lines, keep the legs of the divider plumb (one above the other). When scribing vertical lines, keep the legs level. To scribe a line to an irregular surface, set the divider so one leg will follow the irregular surface and the other leg will scribe a line on the material that is being fitted to the irregular surface. (See view B of fig. 2-22.)

## USING THE SURFACE PLATE

Use the surface plate with such tools as parallels, squares, V-blocks, surface gauges, angle plates, and sine bars to make layout lines. Use angle plates similar to the one shown in figure 2-23 to mount work at an angle on the surface plate. To set the angle of the angle plate, use a protractor and rule of the combination square set or use a vernier protractor.

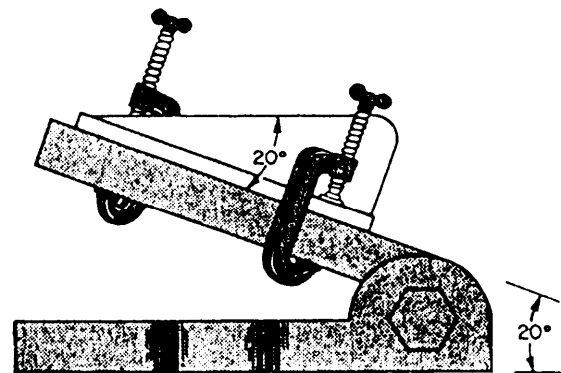


Figure 2-23.—Angle plate.

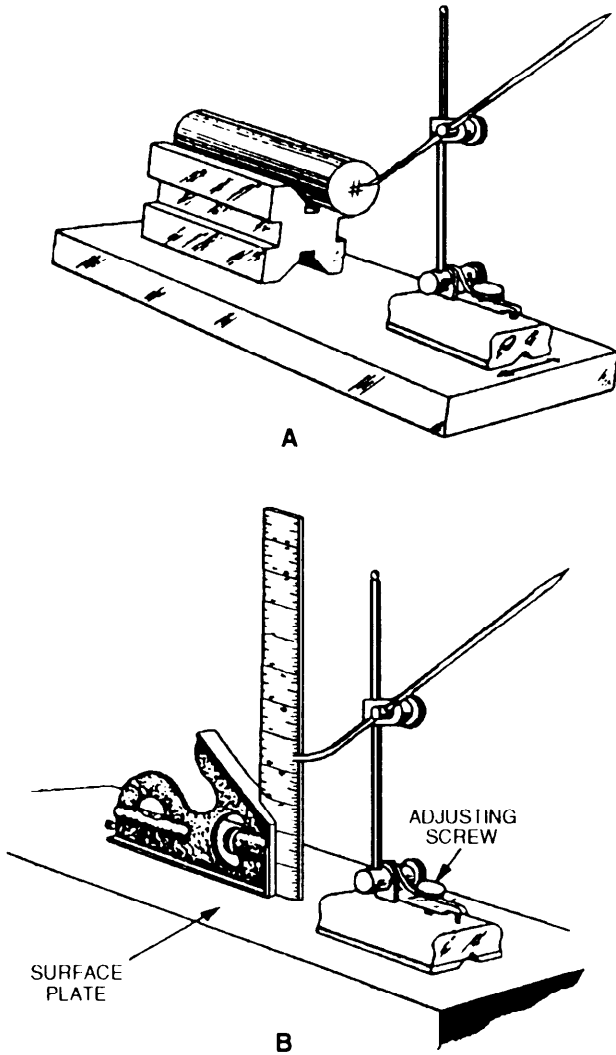


Figure 2-24.—Setting and using a surface gauge.

View A of figure 2-24 shows a surface gauge V-block combination used to lay out a piece of stock. To set a surface gauge for height, first clean the top of the surface plate and the bottom of the surface gauge.

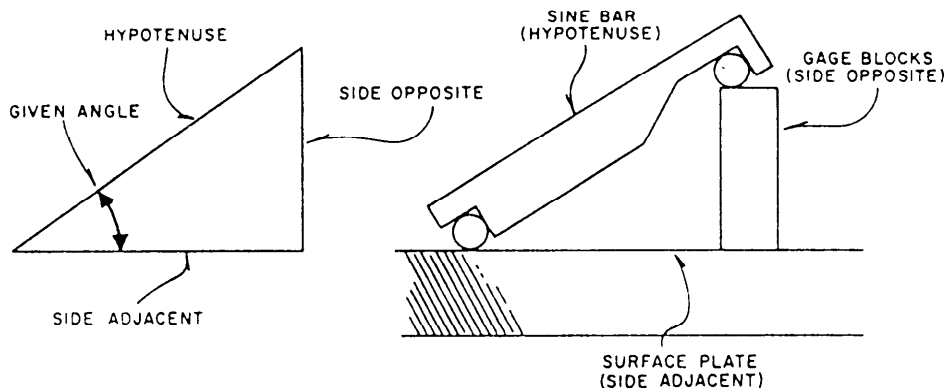


Figure 2-25.—Setup of the sine bar.

Then, place the squaring head of a combination square, as shown in view B. Secure the scale so the end is in contact with the surface of the plate. Move the surface gauge into position.

### USING THE SINE BAR

A sine bar is a precisely machined tool steel bar used with two steel cylinders. In the type shown in figure 2-25, the cylinders establish a precise distance of either 5 inches or 10 inches from the center of one to the center of the other, depending upon the model used. The bar itself has accurately machined parallel sides, and the axes of the two cylinders are parallel to the adjacent sides of the bar within a close tolerance. Equally close tolerances control the cylinder roundness and freedom from taper. The slots or holes in the bar are for convenience in clamping workpieces to the bar. Although the illustrated bars are typical, there is a wide variety of specialized shapes, widths, and thicknesses.

The sine bar itself is very easy to set up and use. You do need a basic knowledge of trigonometry to understand how it works. When a sine bar is set up, it always forms a right triangle. A right triangle has one 90-degree angle. The base of the triangle, formed by the sine bar, is the surface plate, as shown in figure 2-25. The side opposite is made up of the gauge blocks that raise one end of the sine bar. The hypotenuse is always formed by the sine bar, as shown in figure 2-25. The height of the gauge block setting may be found in two ways. The first method is to multiply the sine of the angle needed by the length of the sine bar. The sine of the angle may be found in any table of natural trigonometric functions. For example, if you had to set a 10-inch sine bar to check a  $30^{\circ}5'$  angle on a part, you would first go to a table of

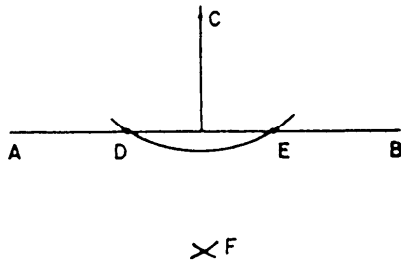


Figure 2-26.—Layout of a perpendicular from a point to a line.

natural trigonometric functions and find the sine of  $30^{\circ}5'$ . Then, multiply the sine value by 10 inches ( $0.50126 \times 10 = 5.0126$ ) to find the height of the gauge blocks. The second method is to use a table of sine bar constants. These tables give the height setting for any given angle (to the nearest minute) for a 5-inch sine bar. Tables are not normally available for 10-inch bars because it is easy to use the sine of the angle and move the decimal point one place to the right.

Although sine bars appear to be rugged, you should give them the same care as gauge blocks. Since they are used with other tools or parts that are heavy, they are subject to rough usage. Remove or repair scratches, nicks, and burrs. Keep them clean from abrasive dirt and sweat and other corrosive agents. Make regular inspections to locate defects before they affect the accuracy of the bar. When you store sine bars for extended periods, clean all bare metal surfaces and then cover them with a light film of oil. Place a cover over the sine bar to prevent accidental damage and to discourage corrosion.

## GEOMETRIC CONSTRUCTION OF LAYOUT LINES

Sometimes you will need to scribe a layout that cannot be made with conventional layout methods. For example, you cannot readily make straight and angular layout lines on sheet metal with irregular edges by using a combination square set. Neither can you mount sheet metal on angle plates in a manner that permits scribing angular lines. Geometric construction is the answer to this problem.

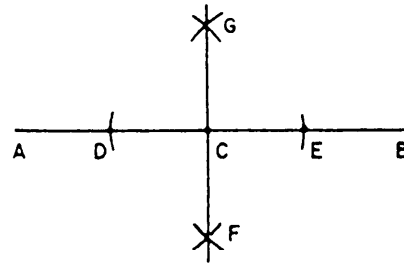


Figure 2-27.—Layout of a perpendicular from a point on a line.

Use a divider to lay out a perpendicular FROM a point TO a line, as shown in figure 2-26. Lightly prick-punch point C, then swing any arc from C that will intersect line AB. Prick-punch intersections D and E, as in the figure. With D and E as centers, scribe two arcs that intersect at a point such as F. Place a straightedge on points C and F. The line drawn along this straightedge from point C to line AB will be perpendicular ( $90^{\circ}$ ) to line AB.

Use a divider to lay out a perpendicular FROM a point ON a line, as shown in figure 2-27. Lightly prick-punch point C on line AB. Then, set the divider to any distance to scribe arcs that intersect AB at D and E with C as the center. Punch C and E lightly. With D and E as centers and with the setting of the divider increased somewhat, scribe arcs that cross at points such as F and G. The line drawn through F and G will pass through point C and be perpendicular to line AB.

To lay out parallel lines with a divider, set the divider to the selected dimension. Then, referring to figure 2-28, from any points (prick-punched) such as C and D on line AB, swing arcs EF and GH. Then, draw line IJ tangent to these two arcs and it will be parallel to line AB and at the selected distance from it.

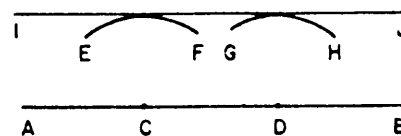


Figure 2-28.—Layout of a parallel line.

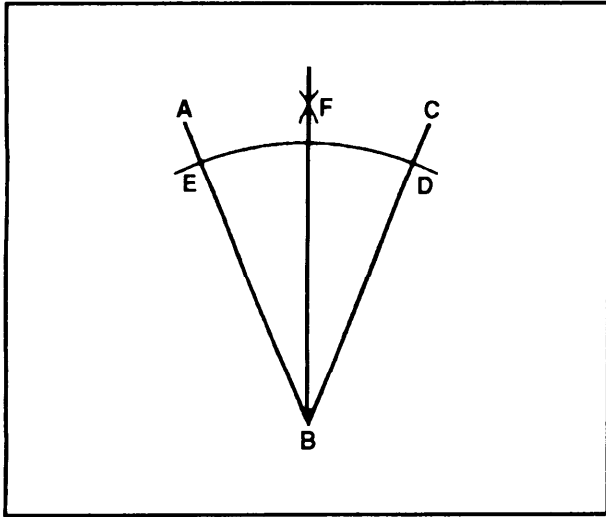


Figure 2-29.—Bisecting an angle.

To bisect an angle, let's assume angle ABC (fig. 2-29) is given. With B as a center, draw an arc cutting the sides of the angle at D and E. With D and E as centers, and with a radius greater than half of arc DE, draw arcs intersecting at F. Then, draw a line from B through point F to bisect angle ABC.

### LAYING OUT VALVE FLANGE BOLT HOLES

Before describing the procedure used to make valve flange layouts, we need to clarify the terminology used in the description. Figure 2-30 shows a valve flange with the bolt holes marked on the bolt circle. The straight-line distance between the centers of two adjacent holes is called the **PITCH CHORD**. The bolt hole circle itself is called the **PITCH CIRCLE**. The vertical line across the face of the flange is the **VERTICAL BISECTOR**, and the horizontal line across the face of the flange is the **HORIZONTAL BISECTOR**.

The bolt holes center on the pitch circle and are equal in distance. The pitch chord between any two adjacent holes is exactly the same as the pitch chord between any other two adjacent holes. Note that the two top holes and the two bottom holes straddle the vertical bisector; the vertical bisector cuts the pitch chord for each pair exactly in half. This is the standard method used to place the holes for a 6-hole flange. In the 4-, 8-, or 12-hole flange, the bolt holes straddle both the vertical and horizontal bisectors. This system of hole placement permits a valve to be

installed in a true vertical or horizontal position. This assumes that the pipe flange holes are also in the standard location on the pitch circle. Before you do a valve flange layout job, find out whether the holes are to be placed in the standard position. If you are working on a "per sample" job, follow the layout of the sample.

Assuming you are sure of the size and number of holes and the radius of the pitch circle, use the following procedure to set up the layout for straight globe or gate valve flanges.

1. Fit a fine grain wood plug into the opening in each flange. (See fig. 2-30.) The plug should fit snugly and be flush with the face of the flange.

2. Apply layout dye to the flange faces, or, if dye is not available, rub chalk on the flange faces to make the drawn lines clearly visible.

3. Locate the center of each flange with a surface gauge, or use a center head and rule combination if the flange diameter is relatively small. (See view A, fig. 2-24 and fig. 2-19.) After you locate the exact center point on each flange, mark the center with a sharp prick-punch.

4. Use dividers to scribe the pitch or bolt circle. Check to see that the pitch circle and the outside edge of the flange are concentric.

5. Draw the vertical bisector. This line must pass through the center point of the flange and must be visually located directly in line with the axis of the valve stem (see fig. 2-30).

6. Draw the horizontal bisector. This line also must pass through the center point of the flange and must be laid out at a right angle to the vertical bisector. (See fig. 2-30 and fig. 2-27.)

Up to this point, the layout is the same for all flanges regardless of the number of holes. Beyond this point, however, the layout differs with the number of holes. The layout for a 6-hole flange is the simplest one and we'll describe it first.

### Six-Hole Flange

Set your dividers exactly to the dimension of the pitch circle radius. Place one leg of the dividers on the point where the horizontal bisector crosses the pitch circle on the right-hand side of the flange. (Point 1 in view A of figure 2-3 1.) Draw a small arc across the pitch circle at points 2 and 6. Next, place one leg of the dividers at the intersection of the pitch

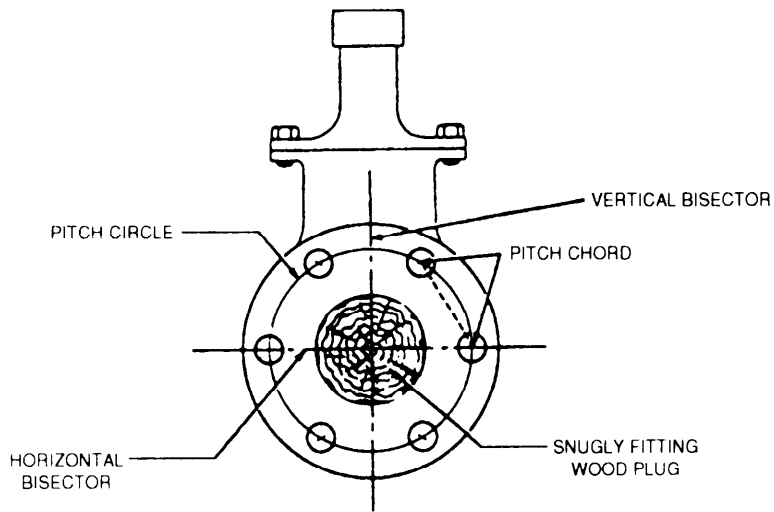


Figure 2-30.—Flange layout terminology.

circle and the horizontal bisector on the left-hand side of the flange point 4. Draw a small arc across the pitch circle line at points 3 and 5. These points (1 to 6) are the centers for the holes. Check the accuracy of the pitch chords. To do this, leave the dividers set exactly as you had them set to draw the arcs. Starting from the located center of any hole, step around the

circle with the dividers. Each pitch chord must be equal to the setting of the dividers. If it is not, you have an error in hole mark placement that you must correct before you center punch the marks for the holes. After you are sure the layout is accurate, center punch the hole marks and draw a circle of appropriate size around each center-punched mark and

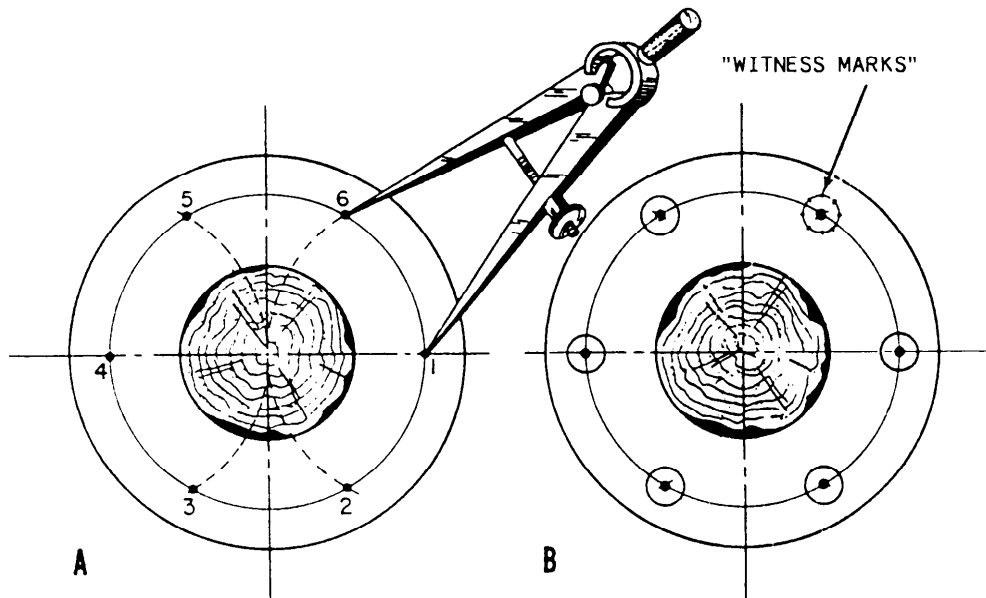


Figure 2-31.—Development of a 6-hole flange.

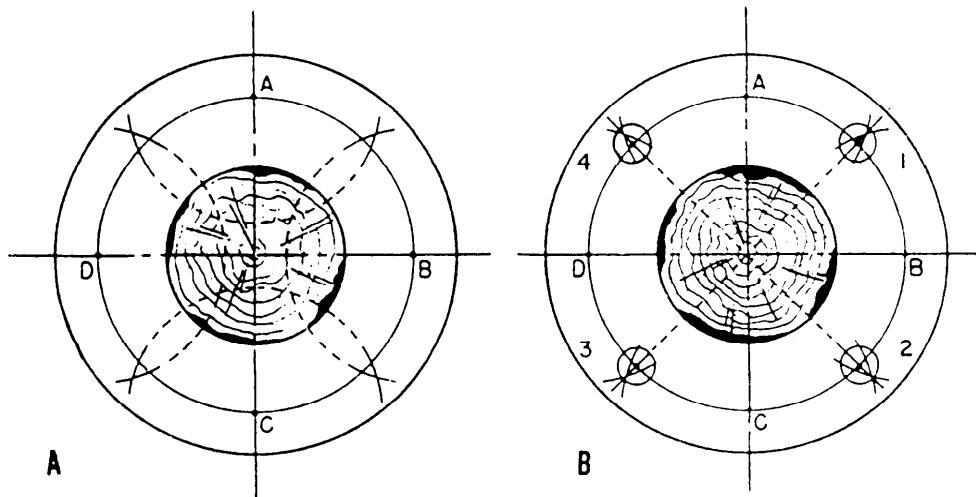


Figure 2-32.—Four-hole flange development.

prick-punch “witness marks” around the circumference, as shown in view B of figure 2-31. These witness marks will be cut exactly in half by the drill to verify a correctly located hole.

### Four-Hole Flange

Figure 2-32 shows the development for a 4-hole flange layout. Set your dividers for slightly more than half the distance of arc AB. Scribe an intersecting arc across the pitch circle line from points A, B, C, and D, as shown in view A of figure 2-32. Next, draw a short radial line through the point of intersection of each pair of arcs as shown in view B. The points where these lines cross the pitch circle (1, 2, 3, and 4) are the centers for the holes. To check the layout for

accuracy, set your divider for the pitch between any two adjacent holes and step around the pitch circle. If the holes are not evenly spaced, find your error and correct it. When the layout is correct, follow the center-punching and witness-marking procedures described for the 6-hole flange layout.

### Eight-Hole Flange

Figure 2-33 shows the development of an 8-hole flange. First locate point E by the same method described to locate point 1 in the 4-hole layout. Then, divide arc AE in half by the same method. The midpoint of arc AE is the location for the center of the hole (1). (Set view A of fig. 3-33.) Next, set your dividers for distance A (1), and draw an arc across the

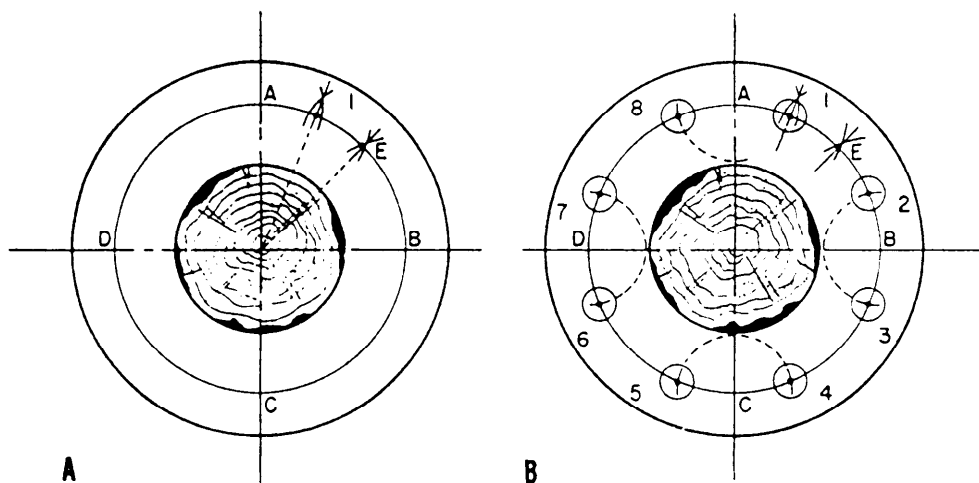


Figure 2-33.—Eight-hole flange development.

pitch circle line from A at point 8; from B at points 2 and 3; from C at 4 and 5; and from D at 6 and 7. (See view B of fig. 2-33.) Now, set your calipers for distance AE and gauge the pitch chord for accuracy. Then, finish the layout as described in the preceding paragraphs.

### Mathematical Determination of Pitch Chord Length

In addition to the geometric solutions given in the preceding paragraphs, you can determine the spacing of valve flange bolt hole centers by simple multiplication, if you know a constant value for the desired number of bolt holes. The diameter of the pitch circle multiplied by the constant equals the length of the pitch chord. The constants for specified numbers of holes are given in table 2-1.

Here is an example of the use of the table. Suppose a flange is to have 9 bolt holes laid out on a pitch circle with a diameter of 10 inches. From the table, select the constant for a 9-hole flange. The pitch diameter (10 inches) multiplied by the appropriate constant (.342) equals the length of the pitch chord (3.420 inches). Set a pair of dividers to measure 3.420 inches, from point to point, and step off around the circumference of the pitch circle to locate the centers of the flange bolt holes. Note, however, that the actual placement of the holes in relation to the vertical and horizontal bisectors is determined separately. (This is of no concern if the layout is for an unattached pipe flange rather than for a valve flange.)

### SCRAPING AND BLUING

Scraping produces a surface that is more accurate in fit and smoother in finish than a machined surface. It is a skill that requires a great deal of practice before you become proficient at it. You need patience, sharp tools, and a light "feel" to scrape a surface until the fit is smooth and uniform.

Some of the tools you will use for scraping will be similar to files without the serrated edges. They are available either straight or with various radii or curves used to scrape an internal surface at selected points. Other scraper tools may look like a paint scraper, possibly with a carbide tip attached. You may find that a scraper you make from material in your shop will be best for the job at hand.

When you scrape a flat surface, you'll need a surface plate and nondrying Prussian blue. Lightly

Table 2-1.—Constants for Locating Centers of Flange Bolt Holes

No. bolt holes	Constant
3 - - - - -	0.866
4 - - - - -	.7071
5 - - - - -	.5879
6 - - - - -	.5
7 - - - - -	.4338
8 - - - - -	.3827
9 - - - - -	.342
10 - - - - -	.309
11 - - - - -	.2817
12 - - - - -	.2588
13 - - - - -	.2394
14 - - - - -	.2225
15 - - - - -	.2079
16 - - - - -	.195
17 - - - - -	.184
18 - - - - -	.1736
19 - - - - -	.1645
20 - - - - -	.1564

coat the surface plate with blue and move the workpiece over this surface. The blue will stick to the high spots on the workpiece, revealing the areas to be scraped. (See fig. 2-34.) Scrape the areas of the workpiece surface that are blue and check again. Continue this process until the blue coloring shows on the entire surface of the workpiece. To reduce frictional "drag" between mating finished scraped surfaces, rotate the solid surfaces so you make each series of scraper cuts at an angle of 90° to the preceding series. This gives the finished scraped surface a crosshatched or basket weave appearance.

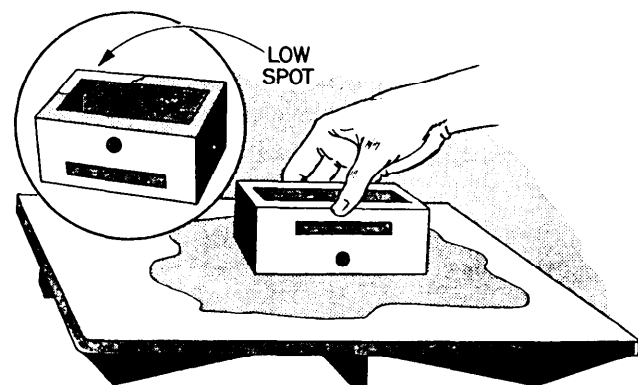
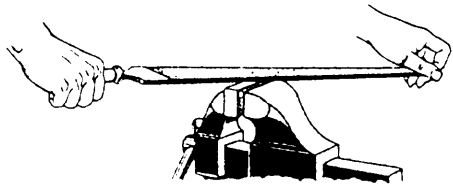
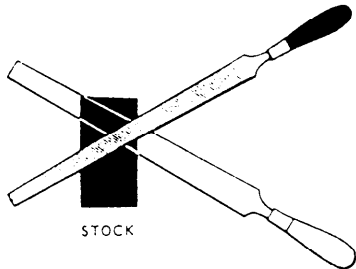


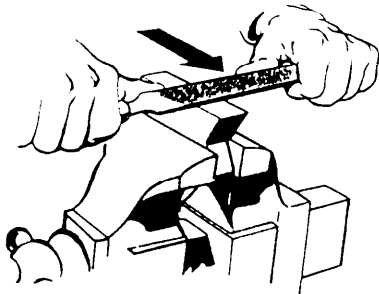
Figure 2-34.—Checking a surface.



A. CROSSFILING A PIECE OF MILD STEEL



B. ALTERNATING POSITIONS WHEN FILING



C. DRAWFILING A SMALL PART

Figure 2-35.—Filing.

The crosshatched method helps you see where you have scraped the part.

## FILING

A file is nearly indispensable when you work with metal. You may be crossfiling, drawfiling, precision filing, or using a file card. Let's examine these operations.

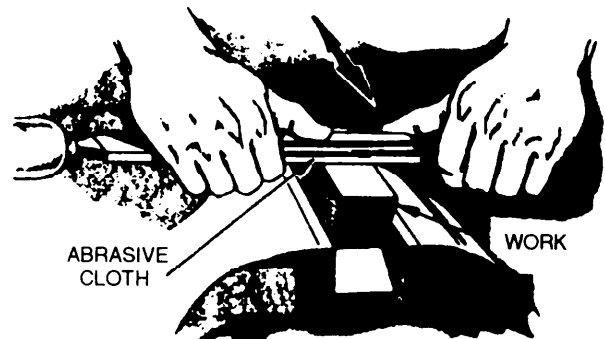
### CROSSFILING

Figure 2-35, view A shows a piece of mild steel being crossfiled. This means that the file is being moved across the surface of the work in a crosswise direction. Keep your feet spread apart to steady

yourself as you file with slow, full-length, steady strokes. The file cuts as you push it. Ease up on the return stroke to keep from dulling the teeth. View B of figure 2-35 shows the alternate positions of the file when an exceptionally flat surface is required. Using either position first, file across the entire length of the stock. Then, using the other position, file across the entire length of the stock again. Because the teeth of the file pass over the surface of the stock from two directions, the high spots and low spots will be visible after filing in both positions. Continue filing first in one direction and then the other until the surface has been filed flat. Test the flatness with a straightedge, or where precision is required, with Prussian blue and a surface plate.

## DRAWFILING

Drawfiling produces a finer surface finish than crossfiling. Small parts, as shown in view C of figure 2-35, are best held in a vise. Hold the file as shown in the figure. Notice that the arrow indicates that the cutting stroke is away from you when the handle is held in the right hand. If the handle is held in the left hand, the cutting stroke will be toward you. Lift the file away from the surface of the work on the return stroke. When drawfiling no longer improves the surface texture, wrap a piece of abrasive cloth around the file and polish the surface, as shown in figure 2-36.



D. POLISHING METAL WITH ABRASIVE CLOTH WRAPPED AROUND A FILE

Figure 2-36.—Polishing.



## USING THE FILE CARD AND BRUSH

As you file, the teeth of the file may become clogged with metal filings and scratch your work. This is known as PINNING. You can prevent pinning by keeping the file teeth clean. Rubbing chalk between the teeth will help prevent pinning, but the best method is to clean the file often with a file card and brush. This tool (fig. 2-37) has fine wire bristles on one side and a stiff brush on the other side. Use the file card with a pulling motion, holding it parallel to the rows of teeth. Then, use the brush to remove any loose filings.

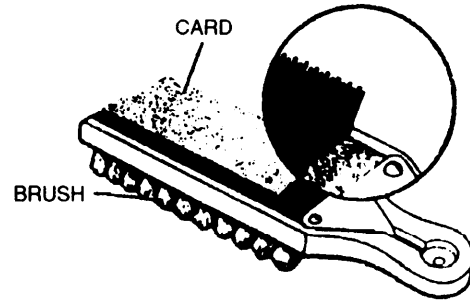


Figure 2-37.—File card with brush.

## HYDRAULIC AND ARBOR PRESSES

Hydraulic and arbor presses are used in many Navy machine shops. They are used to force broaches through parts, assemble and disassemble equipment with force-fitted parts, and many other shop projects.

Arbor presses are usually bench mounted with a gear and rack arrangement. Use them for light pressing jobs, such as to press arbors or mandrels into a part or to force a small broach through a part.

Hydraulic presses can be either vertical or horizontal, although the vertical design is probably more common and versatile. A hydraulic press can generate pressure ranging from about 10 to 100 tons in most Navy machine shops. The pressure can be exerted by either a manually operated pump or an electrohydraulic pump.

Regardless of the type of press equipment you use, be sure to operate it correctly. The only way you can determine the amount of pressure a hydraulic press exerts is by watching the pressure gauge. A part being pressed can reach the breaking point without any visible indication that too much pressure is being applied. When using the press, you must consider the interference allowance between mating parts; corrosion and marred edges; and overlooked fastening devices, such as pins, setscrews, and retainer rings.

Observe the following safety precautions when you use presses:

- Always wear safety glasses and a face shield.
- Make sure the work is adequately supported.

- Place the ram in contact with the work by hand, so the work is positioned accurately in alignment with the ram.

- Use a piece of brass or other material (slightly softer than the workpiece) between the face of the ram and the work to prevent mutilation of the surface of the workpiece.

- Watch the pressure gauge when you use a hydraulic press. You cannot determine the pressure exerted by “feel.” If you begin to apply excessive pressure, release the pressure and double check the work to find the cause.

- When pressing parts together, if possible, use a lubricant between the mating parts to prevent seizing.

Most handbooks for machinists have information concerning the pressure required to force fit two mating parts together. The distance the parts must be pressed directly affects the required pressure, and increased interference allowance requires greater pressure. As a guideline you can use to force-fit a cylindrical shaft, the maximum pressure, in tons, should not exceed 7 to 10 times the shaft’s diameter in inches.

As an example of operating a press, we’ll explain how to broach a keyway. Broaching is a machining process that cuts or shears the material by forcing a broach through the part in a single stroke. A broach is a tapered, hardened bar, into which teeth have been cut. The teeth are small at the beginning of the tool and get progressively larger toward the end of the tool. The last several teeth will usually be the correct size of the desired shape. Broaches are available to cut round, square, triangular, and hexagonal holes as well as internal splines and gears and keyways. A

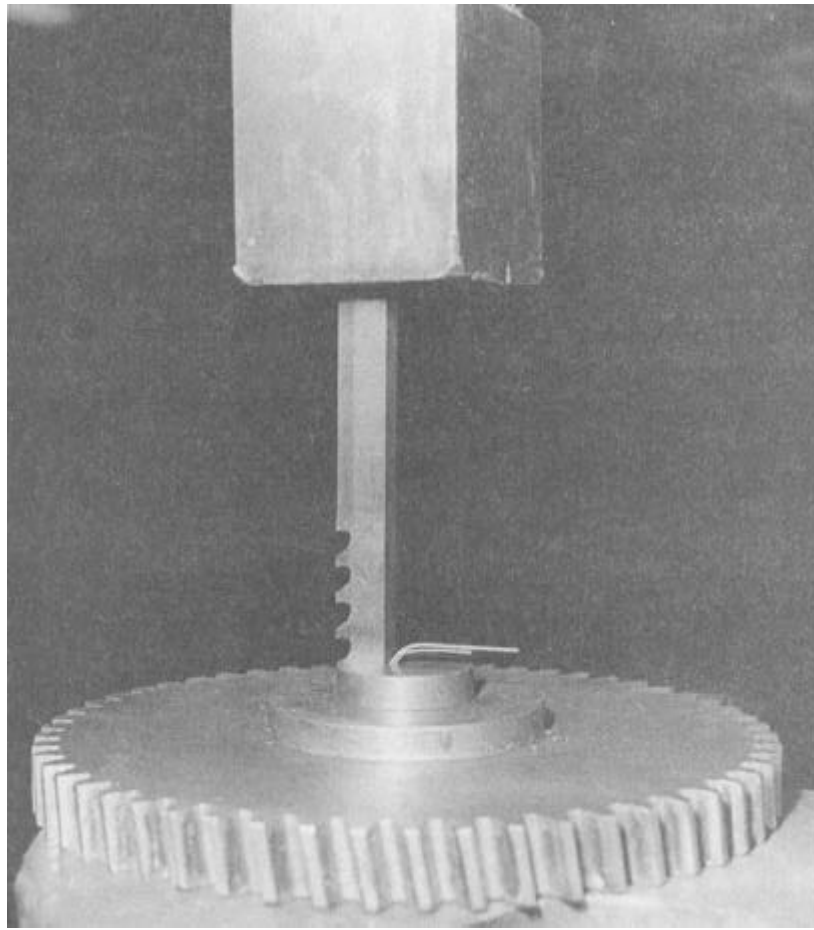


Figure 2-38.—Broaching a keyway on a gear.

28.33

keyway broach requires a bushing that will fit snugly in the hole of the part and has a rectangular slot in it to slide the broach through. Shims of different thicknesses are placed behind the broach to adjust the depth of the keyway cut (fig. 2-38).

A broach is a relatively expensive cutting tool and is easily rendered useless if it is not used and handled properly. Like all other cutting tools, store it so no cutting edge is in contact with any object that could chip or dull it. Preparation of the part to be broached is as important as the broaching operation itself. Make the size of the hole so the beginning pilot section enters freely but does not allow the broach to fall freely past the first cutting edge or tooth. If the hole to be broached has flat sides opposite each other, you need only to measure across them and allow for some error from drilling. The broach will sometimes have the drill size printed on it. Be sure the area

around the hole to be broached is perpendicular on both the entry and exit sides.

You will need a considerable amount of pressure to broach, so be sure the setup is rigid and all safety precautions are strictly observed. Use a slow, even pressure to push the broach through the part. That will produce the most accurate and most safe results with the least damage to the broach. Do not bring the broach back up through the hole, push it on through and catch it with a soft cushion of some type. Use a lubricant to broach most metals. They help to cool the tool, wash away chips, and prevent particles from galling or sticking to the teeth.

### SCREW THREAD INSERTS

A screw thread insert (called inserts for the remainder of this section) is a helically wound coil designed to screw into an internally threaded hole and

receive a standard-sized externally threaded fastener (fig. 2-39). An insert can be used to repair a threaded hole when the threads have been corroded or stripped away. It also increases thread strength when the base metal of the part is aluminum, zinc, or other soft materials. Before using inserts for a repair job, carefully evaluate the feasibility of using this method. When you have no specific guidance, ask your supervisor and refer to your Type Commander Quality Assurance Manual.

Inserts come in sizes up to 1 1/2-inch in diameter in both American National and Unified, and both coarse and fine thread series. The overall length of an insert is based on a fractional multiple of its major diameter. A 1/2-inch insert is available in lengths of 1/2 inch, 3/4 inch, 1 inch, and so on. Inserts are normally made from stainless steel. However, phosphor bronze and nickel alloy inserts are available by special order.

Several tools are used to install and remove inserts. They are essential if the job is to be done correctly. The most important tool is the tap used to thread the hole that the insert will be screwed into. These taps are oversized by specific amounts according to the size of the insert. The oversize tap should provide a class 2B or 3B when the insert is installed. As an example of the amount of oversize involved, a tap required for a 1/2 - 13 UNC insert has a maximum major diameter of 0.604 inch. Because of the increase in the size of the hole required, be sure there is enough material around the hole on the part to provide strength. A rule of thumb is that the minimum amount of material around the hole should equal the thread size of the insert, measured from the center of the hole. Using this rule, a 1/2 - 13 UNC insert will

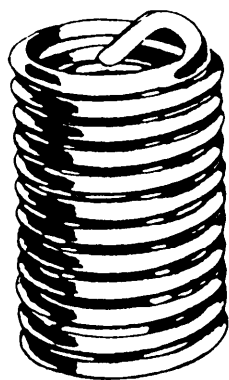


Figure 2-39.—Screw thread insert.

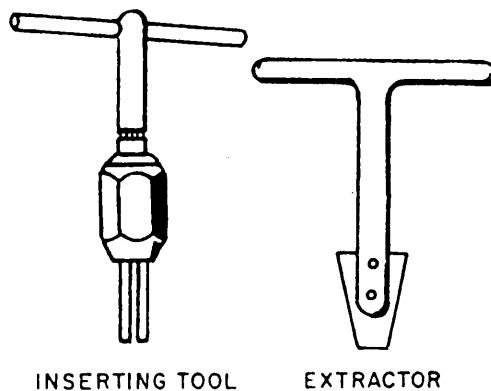


Figure 2-40.—Screw thread insert tools.

require a 1/2-inch distance from the center of the hole to the nearest edge of the part. The tap drill size for each of the taps is marked on the shank of the tap. The diameter of this drill will sometimes vary according to the material being tapped.

The next tool you will use is an inserting tool (fig. 2-40). There are several styles designed for a specific range of insert sizes. Within each of these styles are tools for each size of insert. All of the inserting tools have similar operating characteristics. Either slip the insert over or screw it onto the shank of the tool until the tang (the horizontal strip of metal shown at the top of the insert in figure 2-39) solidly engages the shoulder or recess on the end of the tool. Then, install the insert by turning the tool until the correct depth is reached. Remove the tool by reversing the direction of rotation.

After you have the insert properly installed, break off the tang. This prevents interference with the fastener that will be screwed into the hole. A tang break-off tool is available for all insert sizes of 1/2 inch and below. The tang has a slight notch ground into it that will give way and break when struck with the force of the punch-type, tang break-off tool. On insert sizes more than 1/2 inch, use a long-nosed pair of pliers to move the tang back and forth until it breaks off.

When you must remove a previously installed insert, use an extracting tool (fig. 2-40). There are several different sized tools that cover a given range of insert sizes; be sure you select the right one. Insert the tool into the hole so the blade contacts the top coil of the insert approximately 90° from the beginning of the insert coil. Then, lightly hit the tool to cause the blade to cut into the coil. Turn the tool counter-clockwise until the insert is clear.

The steps involved in repairing a damaged threaded hole with a screw thread insert are as follows:

1. Determine the original threaded hole size. Select the correct standard-sized screw thread insert with the length that best fits the application. Be sure the metal from which the insert is made is recommended for the particular application.

2. Select the correct tap for the insert to be installed. Some taps come in sets of a roughing and a finishing tap.

3. Select the correct size of drill based on the information on the shank of the tap or from charts normally supplied with the insert kits. Measure the part with a rule to determine if the previously referenced minimum distance from the hole to the edge of the part exists. With all involved tools and parts secured rigidly in place, drill the hole to a minimum depth that will permit full threads to be tapped a distance equaling or exceeding the length of the insert, not counting any spot-faced or countersunk area at the top of the hole. Remove all chips from the hole.

4. Tap the hole. Use standard tapping procedures in this step. If the tapping procedure calls for both roughing and finishing taps, be sure to use both taps before you install the insert. Use lubricants to improve the quality of the threads. When you have completed the tapping, inspect the threads to make sure full threads have been cut to the required depth of the hole. Remove all chips.

5. Next, install the insert. If the hole being repaired is corroded badly, apply a small amount of preservative to the tapped threads immediately before installing the insert. Position the insert on the insert tool as required by the particular style being used. Turn the tool clockwise to install the insert. Continue to turn the tool until the insert is approximately 1/2 turn below the surface of the part. Remove the tool by turning it counterclockwise.

6. Use an approved antiseize compound when screwing the threaded bolt or stud into the insert. Avoid using similar metals such as a stainless insert and a stainless bolt to prevent galling and seizing of the threads.

## OXYACETYLENE EQUIPMENT

As an MR, you may have to use an oxyacetylene torch to heat parts to expand them enough to permit

assembly or disassembly. Do this with great care and only with proper supervision. This chapter explains the operation of the oxyacetylene torch used to heat parts only. It also covers the safety precautions you must observe when you use the torch and related equipment.

Oxyacetylene equipment (fig. 2-41) consists of a cylinder of acetylene, a cylinder of oxygen, two regulators, two lengths of hose with fittings, a welding torch with tips, and either a cutting attachment or a separate cutting torch. Accessories include a spark lighter to light the torch; an apparatus wrench to fit the various connections, regulators, cylinders, and torches; goggles with filter lenses to protect the eyes, and gloves to protect the hands. Wear flame-resistant clothing when necessary.

Acetylene ( $C_2H_2$ ) is a fuel gas made up of carbon and hydrogen. When burned with oxygen, acetylene produces a very hot flame with a temperature between  $5700^\circ$  and  $6300^\circ F$ . Acetylene gas is colorless, but has a distinct, easily recognized odor. The acetylene used on board ship is usually taken from compressed gas cylinders.

Oxygen is a colorless, tasteless, odorless gas that is slightly heavier than air. Oxygen will not burn by itself, but it will support combustion when combined with other gases. You must be extremely careful to make sure compressed oxygen does not become contaminated with hydrogen or hydrocarbon gases or liquids, unless the oxygen is controlled by such means as the mixing chamber of a torch. A highly explosive mixture will be formed if uncontrolled compressed oxygen becomes contaminated. NEVER let oxygen come in contact with oil or grease.

The gas pressure in a cylinder must be reduced to a suitable working pressure before it can be used. This is done with a regulator or reducing valve. Regulators are either the single-stage or the double-stage type. Single-stage regulators reduce the pressure of the gas in one step; two-stage regulators do the same job in two steps, or stages. Two-stage regulators generally require less adjustment.

The hose used to make the connection between the torch and the regulators is strong, nonporous, and light and flexible enough to make torch movements easy. The hose is made to withstand high internal pressures. The rubber from which it is made is specially treated to remove sulfur to avoid the danger of spontaneous combustion. Hose is available in various sizes, depending upon work for which it is

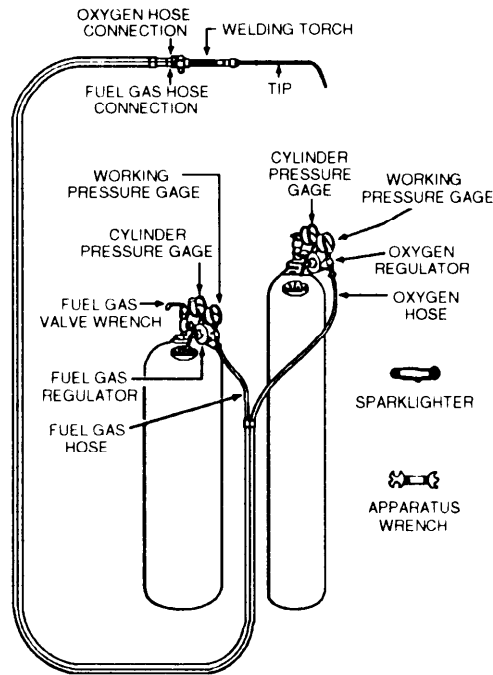


Figure 2-41.—Typical oxyacetylene cylinder bank.

intended. Hose used for light work has a 3/16- or 1/4-inch inside diameter and contains one or two plies of fabric. For heavy-duty welding and handcutting operations, hose with an inside diameter of 1/4 or 5/16 inch and three to five plies of fabric is used. Single hose comes in lengths of 12 1/2 feet to 25 feet. Some manufacturers make a double hose that conforms to the same general specifications. The hoses used for acetylene and oxygen have the same grade, but they differ in color and have different types of threads on the hose fittings. The oxygen hose is GREEN and the acetylene hose is RED. The oxygen hose has right-hand threads and the acetylene hose has left-hand threads to prevent switching hoses during connection.

The oxyacetylene torch is used to mix oxygen and acetylene gas in the proper proportions and to control the volume of these gases burned at the torch tip. Torches have two needle valves, one to adjust the flow of oxygen and the other to adjust the flow of acetylene. In addition, they have a handle (body), two tubes (one for oxygen and one for acetylene), a mixing head, and a tip. Torch tips are made from a special copper alloy that dissipates heat (less than 60 percent copper). They are available in different sizes to handle a wide range of plate thicknesses.

Torch tips and mixers made by different manufacturers differ in design. Some makes of torches have an individual mixing head or mixer for each size of tip. Other makes have only one mixer for several tip sizes. Tips come in various types. Some are one-piece, hard copper tips. Others are two-piece tips that include an extension tube to make connection between the tip and the mixing head. When used with an extension tube, removable tips are made of hard copper, brass, or bronze. Tip sizes are designated by numbers, and each manufacturer has its own arrangement for classifying them. Tips have different hole diameters.

No matter what type or size of tip you select, you must keep the tip clean. Quite often the orifice becomes clogged. When this happens, the flame will not burn properly. Inspect the tip before you use it. If the passage is obstructed, you can clear it with wire tip cleaners of the proper diameter or with soft copper wire. Do not clean tips with machinist's drills or other sharp instruments.

Each different type of torch and tip size requires a specific working pressure to operate properly and safely. You can set pressures by adjusting the regulator gauges to the settings listed on charts provided by the manufacturer.

## SETTING UP OXYACETYLENE EQUIPMENT

Take the following steps to set up oxyacetylene equipment:

1. Secure the cylinders so they cannot be upset. Remove the protective caps.

2. Crack (open) the cylinder valves slightly to blow out any dirt that may be in the valves. Close the valves and wipe the connections with a clean cloth.

3. Connect the acetylene pressure regulator to the acetylene cylinder and the oxygen pressure regulator to the oxygen cylinder. Using the appropriate wrench provided with the equipment, tighten the connecting nuts.

4. Connect the red hose to the acetylene regulator and the green hose to the oxygen regulator. Tighten the connecting nuts enough to prevent leakage.

5. Turn the regulator screws out until you feel little or no resistance, and then open the cylinder valves slowly. Then, open the acetylene valve 1/4 to 1/2 turn. This will allow an adequate flow of acetylene and will allow the valve to be turned off quickly in an emergency. (NEVER open the acetylene cylinder valve more than 1 1/2 turns.) Open the oxygen cylinder valve all the way to eliminate leakage around the stem. (Oxygen valves are double seated or have diaphragms to prevent leakage when open.) Read the high-pressure gauge to check the pressure of each cylinder.

6. Blow out the oxygen hose by turning the regulator screw in and then back out again. If you need to blow out the acetylene hose, do it ONLY in a well-ventilated place that is free from sparks, flames, or other possible sources of ignition.

7. Connect the hoses to the torch. Connect the red acetylene hose to the connection gland that has the needle valve marked AC or ACET. Connect the green oxygen hose to the connection gland that has the needle valve marked OX. Test all hose connections for leaks by turning both regulator screws IN, while the needle valves are closed. Then, turn the regulator screws OUT, and drain the hose by opening the needle valves.

8. Adjust the tip. Screw the tip into the mixing head and screw the mixing head onto the torch body. Tighten the mixing head/tip assembly by hand and

adjust the tip to the proper angle. Secure this assembly with the wrench provided with the torch.

9. Adjust the working pressures. Adjust the acetylene pressure by turning the acetylene gauge screw to the right. Adjust the acetylene regulator to the required working pressure for the particular tip size. (Acetylene pressure should NEVER exceed 15 psig.)

10. Light and adjust the flame. Open the acetylene needle valve on the torch and light the acetylene with a spark lighter. Keep your hand out of the way. Adjust the acetylene valve until the flame just leaves the tip face. Open and adjust the oxygen valve until you get the proper neutral flame. Notice that the pure acetylene flame that just leaves the tip face is drawn back to the tip face when the oxygen is turned on.

## ADJUSTING THE FLAME

A pure acetylene flame is long and bushy and has a yellowish color. It is burned by the oxygen in the air that is not sufficient to burn the acetylene completely. Therefore, the flame is smoky, producing a soot of fine, unburned carbon. The pure acetylene flame is unsuitable for use. When the oxygen valve is opened, the mixed gases burn in contact with the tip face. The flame changes to a bluish-white color and forms a bright inner cone surrounded by an outer flame envelope. The inner cone develops the high temperature required.

The type of flame commonly used to heat parts is a neutral flame. The neutral flame is produced by burning 1 part of oxygen with 1 part of acetylene. The bottled oxygen, together with the oxygen in the air, produces complete combustion of the acetylene. The luminous white cone is well-defined and there is no greenish tinge of acetylene at its tip, nor is there an excess of oxygen. A neutral flame is obtained by gradually opening the oxygen valve to shorten the acetylene flame until a clearly defined inner luminous cone is visible. This is the correct flame to use for many metals. The temperature at the tip of the inner cone is about 5900°F, while at the extreme end of the outer cone it is only about 2300°F. This gives you a chance to exercise some temperature control by moving the torch closer to or farther from the work.

## EXTINGUISHING THE FLAME

To extinguish the oxyacetylene flame and to secure equipment after completing a job, or when work is to be interrupted temporarily, you should take the following steps:

1. Close the acetylene needle valve first; this extinguishes the flame and prevents flashback. (Flashback is discussed later.) Then, close the oxygen needle valve.
2. Close both the oxygen and acetylene cylinder valves. Leave the oxygen and acetylene regulators open temporarily.
3. Open the acetylene needle valve on the torch and allow gas in the hose to escape for 5 to 15 seconds. Do NOT allow gas to escape into a small or closed compartment. Close the acetylene needle valve.
4. Open the oxygen needle valve on the torch. Allow gas in the hose to escape for 5 to 15 seconds. Close the valve.
5. Close both oxygen and acetylene cylinder regulators by backing out the adjusting screws until they are loose.

Follow this procedure whenever your work will be interrupted for an indefinite period. If you stop work for only a few minutes, you don't need to secure the cylinder valves and drain the hoses. However, if you stop for an indefinite time, follow the entire extinguishing and securing procedure. For overnight work stoppage in areas other than the shop, it is a good idea to remove the pressure regulators and the torch from the system. Double check the cylinder valves to make sure they are closed securely.

## SAFETY: OXYACETYLENE EQUIPMENT

When you are heating with oxyacetylene equipment, you must observe certain safety precautions to protect personnel and equipment from injury by fire or explosion. The precautions that follow apply specifically to oxyacetylene work.

- Use only approved apparatus that has been examined and tested for safety.
- When you use cylinders, keep them far enough away from the actual heating area so they will not be reached by the flame or sparks from the object being heated.

- NEVER interchange hoses, regulators, or other apparatus intended for oxygen with those intended for acetylene.
- Keep valves closed on empty cylinders.
- Do NOT stand in front of cylinder valves while opening them.
- When a special wrench is required to open a cylinder valve, leave the wrench in position on the valve stem while you use the cylinder so the valve can be closed rapidly in an emergency.
- Always open cylinder valves slowly. (Do NOT open the acetylene cylinder valve more than 1 1/2 turns.)
- Close the cylinder valves before moving the cylinders.
- NEVER try to force unmatching or crossed threads on valve outlets, hose couplings, or torch valve inlets. These threads are right-handed for oxygen and left-handed for acetylene. The threads on acetylene cylinder valve outlets are right-handed, but have a pitch that is different from the pitch of the threads on the oxygen cylinder valve outlets. If the threads do not match, the connections are mixed.
- Always use the correct tip or nozzle and the correct pressure for the particular work involved. This information should be taken from tables or worksheets supplied with the equipment.
- Do NOT allow acetylene and oxygen to accumulate in confined spaces. Such a mixture is highly explosive.
- Keep a clear space between the cylinder and the work so the cylinder valves may be reached quickly and easily if necessary.
- When lighting the torch, use friction lighters, stationary pilot flames, or some other suitable source of ignition. The use of matches may cause serious hand burns. Do NOT light a torch from hot metal. When lighting the torch, open the acetylene valve first and ignite the gas with the oxygen valve closed. Do NOT allow unburned acetylene to escape into a small or closed compartment.
- When extinguishing the torch, close the acetylene valve first and then close the oxygen valve.
- Do NOT use lubricants that contain oil or grease on oxyacetylene equipment. OIL OR

**GREASE IN THE PRESENCE OF OXYGEN UNDER PRESSURE WILL IGNITE VIOLENTLY.** Consequently, do not let oxygen come in contact with these materials in any way. Do NOT handle cylinders, valves, regulators, hose, or any other apparatus that uses oxygen under pressure with oily hands or gloves. Do NOT permit a jet of oxygen to strike an oily surface or oily clothes.

**NOTE:** A suitable lubricant for oxyacetylene equipment is glycerin.

- NEVER use acetylene from cylinders without reducing the pressure through a suitable pressure reducing regulator. Avoid acetylene working pressures in excess of 15 pounds per square inch. Oxygen cylinder pressure must likewise be reduced to a suitable low working pressure; high pressure may burst the hose.

- Stow all cylinders carefully according to prescribed procedures. Store cylinders in dry, well-ventilated, well-protected places away from heat and combustible materials. Do NOT stow oxygen cylinders in the same compartment with acetylene cylinders. Stow all cylinders in an upright position. If they are not stowed in an upright position, do not use them until they have been allowed to stand upright for at least 2 hours.

- Do not use the torch to heat material without first making certain that hot sparks or hot metal will not fall on your legs or feet, on the hose and cylinder, or on any flammable materials. Be sure a fire watch is posted as required to prevent accidental fires.

- Be sure you and anyone nearby wear flameproof protective clothing and shaded goggles to prevent serious burns to the skin or the eyes. A No. 5 or 6 shaded lens should be sufficient for your heating operations.

- Welding, heating and cutting operations generate metal fumes, smoke and carbon monoxide. Use adequate ventilation, such as a local exhaust hood, to remove fumes and smoke. When ventilation is not available, operators should wear metal fume respirators. Your Safety Officer will specify what type of respirator you need.

These precautions are by no means all the safety precautions that pertain to oxyacetylene equipment, and they only supplement those specified by the

manufacturer. Always read the manufacturer's manual, *Naval Ships' Technical Manual, Navy Occupational Safety and Health (NAVOSH) Program Manual For Forces Afloat*, (OPNAV) INSTRUCTION 5100.19B, and adhere to all precautions and procedures for the specific equipment you are going to be using.

## **BACKFIRE AND FLASHBACK**

Backfire and a flashback are two common problems encountered in using an oxyacetylene torch. Unless the system is thoroughly purged of air and all connections in the system are tight before the torch is ignited, the flame is likely to burn inside the torch instead of outside the tip. The difference between backfire and flashback is that in a backfire, there is a momentary burning back of the flame into the torch tip; in a flashback, the flame burns in or beyond the torch mixing chamber. A backfire is characterized by a loud snap or pop as the flame goes out. A flashback is usually accompanied by a hissing or squealing sound. At the same time, the flame at the tip becomes smoky and sharp-pointed. When a flashback occurs, immediately shut off the torch oxygen valve, then close the acetylene valve.

A flashback indicates that something is radically wrong either with the torch or with the manner of handling it. A backfire is less serious. Usually the flame can be relighted without difficulty. If backfiring continues whenever the torch is relighted, check for an overheated tip, gas working pressures greater than that recommended for the tip size being used, a loose tip, or dirt on the torch tip seat. These same difficulties may be the cause of a flashback, except that the difficulty is present to a greater degree. For example, the torch head may be distorted or cracked.

In most instances, backfires and flashbacks result from carelessness. To avoid these difficulties, always make certain (1) all connections in the system are clean and tight, (2) torch valves are closed (not open or merely loosely closed) when the equipment is stowed, (3) the oxygen and acetylene working pressures used are those recommended for the torch, and (4) you have purged the system of air before using it. Purging the system of air is especially necessary when the hose and torch have been newly connected or when a new cylinder is put into the system.



## CHAPTER 3

# METALS AND PLASTICS

### CHAPTER LEARNING OBJECTIVES

*Upon completing this chapter, you should be able to do the following:*

- *Explain the methods used to select metals for various applications.*
- *Explain the methods used to select plastics for various applications.*

An MR repairs broken parts and manufactures replacements according to samples and blueprints. To choose the metals and plastics best suited for that purpose, you must know the physical and mechanical properties of materials. You also must know how to identify materials that are not clearly marked. For instance, stainless steel and nickel-copper are quite similar in appearance, but they are completely different in their mechanical properties and cannot be used interchangeably. Some of the properties of materials that an MR must know are presented in this chapter.

As with any shop equipment you must observe all posted safety precautions. Review your equipment operators manual for safety precautions and any chapters of *Navy Occupational Safety and Health (NAVOSH) Program Manual for Forces Afloat*, OPNAV Instruction 5100.19B, that pertain to the equipment you will be operating.

Many alloy metals are toxic, and can be potentially carcinogenic. The dust or fumes given off by these alloys could be inhaled and cause serious health problems. Respiratory protection may be required when machining, sanding or melting alloy metals.

### METALS

There are hundreds of metals and alloys that you may machine in a machine shop. You need not understand all metals and alloys, but you must have a working knowledge of them and know the common terms associated with them.

### PROPERTIES OF METAL

The physical properties of a metal determine its behavior under stress, heat, and exposure to chemically active substances. In practical application, the behavior of a metal under these conditions determines its mechanical properties; indentation and rusting. The mechanical properties of a metal are important considerations in selecting material for a specific job.

#### Stress

Stress in a metal is its internal resistance to a change in shape when an external load or force is applied to it. There are three different forms of stress. Tensile stress pulls a metal apart. Compression stress squeezes the metal. Shear stress is forces from opposite directions that work to separate the metal. When a piece of metal is bent, both tensile and compression stresses are applied. The side of the metal where the force is applied undergoes tensile stress as the metal is stretched, while the opposite side is squeezed under compression stress. When a metal is subjected to torque, such as a pump shaft driven by an electric motor, all three forms of stress are applied to some degree.

#### Strain

Strain is the deformation or change in shape of a metal when a stress or load is applied. When the load is removed, the metal is no longer under a strain. The type of deformation will be similar to the form of stress applied.

## **Strength**

Strength is the property of a metal that enables it to resist strain (deformation) when a stress (load) is applied. Strength may be expressed by several different terms. The most common term is *tensile strength*, or the maximum force required to pull metal apart. To find tensile strength, divide the force required to pull the metal apart by the area in square inches of a prepared specimen.

Another term used to describe the strength of a metal is *yield strength*, which you will determine during the test for tensile strength. Yield strength is established when the metal specimen begins to stretch while pressure is gradually applied. There is often a relationship between the tensile strength and the hardness of metals. As the hardness of a metal is increased, the tensile strength is also increased, and vice versa. Charts provide these values for the more commonly used metals.

## **Plasticity**

Plasticity is the ability of a metal to withstand extensive permanent deformation without breaking or rupturing. Modeling clay is an example of a highly plastic material, since it can be deformed extensively and permanently without rupturing. Metals with high plasticity will produce long, continuous chips when machined on a lathe.

## **Elasticity**

Elasticity is the ability of a metal to return to its original size and shape after an applied force has been removed. The action of spring steel is an example of applying this property.

## **Ductility**

Ductility is the ability of a metal to be permanently deformed when it is bent or stretched into wire form without breaking. To find the ductility of a metal, apply the tensile strength test and measure the percentage of increased length. Copper is an example of a very ductile metal.

## **Malleability**

Malleability is the ability of a metal to be permanently deformed by a compression stress produced by hammering, stamping, or rolling the

metal into thin sheets. Lead is a highly malleable metal.

## **Brittleness**

Brittleness is the tendency of a metal to break or crack when it has not been deformed. Generally, the harder a metal, the more brittle it is, and vice versa. Pot metal and cast iron are examples of brittle metals.

## **Toughness**

Toughness is the ability of a metal to withstand shock, to endure stress, and to deform without breaking. A tough metal is not easily separated or cut and can be bent first in one direction and then in the opposite without fracturing.

## **Hardness**

Hardness of a metal is generally defined as its ability to resist indentation, abrasion or wear, and cutting. The degree of hardness of many metals may be either increased or decreased by one or more heat-treatment processes. In most cases, as the hardness of a steel is decreased, its toughness is increased.

## **Hardenability**

Hardenability is a measure of the depth (from the metal's surface toward its center) to which a metal can be hardened by heat treatment. A metal that achieves a shallow depth of hardness and retains a relatively soft and tough core has low hardenability. The hardenability of some metals changes by adding certain alloys during manufacturing.

## **Fatigue**

Fatigue is the action that takes place in a metal after repeated stress. When you break a sample in a tensile machine, you need to apply a definite load to cause that fracture. However, the same material will fail under a much smaller load if you apply and remove the load many times. Fatigue may cause a shaft to break after months of use even though the load has not been changed.

## **Corrosion Resistance**

Corrosion resistance is the ability of a metal to withstand surface attack by the atmosphere, fluids, moisture, and acids. Some metals can be made less

susceptible to corrosive agents by either coating or alloying them with other metals that are corrosion resistant.

### **Heat Resistance**

Heat resistance is the property of a steel or alloy that permits it to retain its properties at high temperatures. Examples are tungsten steel, which can cut other metals even when red hot, and chromium molybdenum steel, which is used for piping and valves in high temperature, high-pressure steam systems.

### **Weldability**

Weldability refers to the relative ease with which a metal can be welded. Weldability depends on many different factors. The basic factor is the chemical composition or the elements that were added during the metal's manufacture. A steel with a low carbon content will be much easier to weld than one with a high carbon content. You can weld a low alloy steel that has low hardenability easier than one with a high hardenability. You also must consider the welding procedure, such as gas or arc welding. Charts provide guidelines concerning the weldability of a metal and the recommended welding procedure. Always make weldability an integral part of planning a job that requires welding.

### **Machinability**

Machinability is the relative ease with which a metal can be machined. Several factors affect the machinability of metal. They are different alloying elements, the method used by the manufacturer to form the metal bar (physical condition), any heat treatment that has changed the hardness, whether you use a high-speed steel or carbide cutting tool, and whether you use a cutting fluid. We'll discuss some of these factors later in this chapter.

## **TYPES OF METALS**

Metals are divided into two general types—ferrous and nonferrous. Ferrous metals are those whose major element is iron. Iron is the basis for all steels. Nonferrous metals are those whose major element is not iron, but they may contain a small amount of iron as an impurity.

## **Ferrous Metals**

Iron ore, the basis of all ferrous metals, is converted to metal (pig iron) in a blast furnace. Alloying elements can be added later to the pig iron to obtain a wide variety of metals with different characteristics. The characteristics of metal can be further changed and improved by heat treatment and by hot or cold working.

**PIG IRON.**—The product of the blast furnace is called pig iron. Pig iron is composed of approximately 93 percent iron, 3 to 5 percent carbon, and varying amounts of impurities. It is seldom used directly as an industrial manufacturing material, but it is the basic ingredient in cast iron, wrought iron, and steel.

**CAST IRON.**—Cast iron is produced by resmelting a charge of pig iron and scrap iron in a furnace and removing some of the impurities from the molten metal by using various fluxing agents. There are many grades of cast iron, based on strength and hardness. The quality depends upon the extent of refining, the amount of scrap iron used, and the method of casting and cooling the molten metal when it is drawn from the furnace. The higher the proportion of scrap iron, the lower the grade of cast iron. Cast iron has some degree of corrosion resistance and great compressive strength, but it is brittle and has a comparatively low tensile strength. It has limited use in marine service.

**WROUGHT IRON.**—Wrought iron is a highly refined pure iron that contains uniformly distributed particles of slag. It is considerably softer than cast iron and has a fibrous internal structure. Like cast iron, it is fairly resistant to corrosion and fatigue. Wrought iron, is used extensively for low-pressure pipes, rivets, and nails.

**PLAIN-CARBON STEEL.**—Pig iron is converted into steel by a process that separates and removes impurities from the molten iron by use of various catalytic agents and extremely high temperatures. During the refining process, practically all the carbon originally present in the pig iron is burned out. In the final stages when higher carbon alloys are needed, measured amounts of carbon are added to the relatively pure liquid iron to produce carbon steel of a desired grade. The amount of carbon added controls the mechanical properties of the finished steel. After the steel has been drawn from the furnace and allowed to solidify, it may be sent either to the stockpile or to shaping mills for rolling

and forming into plates, billets, bars, or structural shapes.

Plain steels that have small additions of sulfur (and sometimes phosphorous) are called free-cutting steels. These steels have good machining characteristics and are used in applications similar to carbon steels. The addition of sulfur and phosphorous limits their ability to be formed hot. We will now discuss a few of the plain carbon steels.

**Low-carbon steel.**—Low-carbon steel (0.05 to 0.30 percent carbon), usually called mild steel, can be easily cut and bent and does not have great tensile strength. Steels with less than 0.15 percent carbon are usually more difficult to machine than those with a higher carbon content.

**Medium-carbon steel.**—Medium-carbon steel (0.30 to 0.60 percent carbon) is considerably stronger than low-carbon steel. Heat-treated machinery parts are made of this steel.

**High-carbon steel.**—High-carbon steel (0.60 to 1.50 percent carbon) is used for many machine parts, handtools, and cutting tools and is usually called carbon tool steel. Do not use cutting tools of high-carbon steel when the cutting temperature will exceed 400°F.

**ALLOY STEELS.**—The steels discussed so far are true alloys of iron and carbon. When other elements are added to iron during the refining process, the resulting metal is called alloy steel. There are many types, classes, and grades of alloy steel.

Alloy steels usually contain several different alloying elements, and each contributes a different characteristic to the metal. Alloying elements can change the machinability, hardenability, weldability, corrosion resistance, and surface appearance of the metal. If you know how each of the alloying elements affects a metal, you'll more readily select the best metal for a given application. In the following paragraphs, we'll discuss a few of the more common alloy steels and the effects of certain alloying elements upon the mechanical properties of steel.

**Chromium.**—Chromium is added to steel to increase hardenability, corrosion resistance, toughness, and wear resistance. The most common uses of chromium are in corrosion-resistant steel (commonly called stainless steel) and high-speed cutting tools. Stainless steel is often used to manufacture parts that are used in acids and salt water.

It is also used in parts such as ball bearings, shafts, and valve stems that are subject to high pressure and high temperature.

**Vanadium.**—Vanadium is added in small quantities to steel to increase tensile strength, toughness, and wear resistance. It is most often combined with chromium. It is used for crankshafts, axles, piston rods, springs, and other parts where high strength and fatigue resistance are required. Greater amounts of vanadium are added to high-speed steel cutting tools to prevent tempering of their cutting edges during high temperatures.

**Nickel.**—Nickel is added to steel to increase corrosion resistance, strength, toughness, and wear resistance. Nickel is used in small amounts in the steel used to armor plate a ship because it resists cracking when penetrated. Greater amounts of nickel are added to chromium to produce a metal that withstands severe working conditions. Crankshafts, rear axles, and other parts subject to repeated shock are made from nickel chrome steel.

**Molybdenum.**—Molybdenum is added to steel to increase toughness, hardenability, shock resistance, and resistance to softening at high temperatures. Molybdenum steel is used for transmission gears, heavy-duty shafts, and springs. Carbon molybdenum (CMo) and chrome molybdenum (CrMo) are two alloy steels with molybdenum added that are widely used in high-temperature piping systems in Navy ships. Relatively large amounts of molybdenum are used in some of the cutting tools used in the machine shop.

**Tungsten.**—Tungsten is used primarily in high-speed steel or cemented-carbide cutting tools. It gives the cutting tools their hard, wear-resistant and heat-resistant characteristics. Tungsten can be air-hardened. It allows tools to be hardened without using oil or water to cool the tool after heating.

## Nonferrous Metals

Copper, nickel, lead, zinc, tin, and aluminum are included among the nonferrous metals. These metals and their alloys are used in large amounts in the construction and maintenance of Navy ships.

**COPPER ALLOYS.**—Copper has a variety of uses. You will see it aboard ship in the form of wire, rod, bar, sheet, plate, and pipe. As a conductor of both heat and electricity, copper ranks next to silver and has a high resistance to saltwater corrosion.

Copper becomes hard when worked but can be softened easily if you heat it cherry red and then cool it. Its strength, however, decreases rapidly at temperatures above 400°F.

Pure copper is normally used in molded or shaped forms when machining is not required. Copper for normal shipboard use generally is alloyed with an element that provides good machinability.

**Brass.**—Brass is an alloy of copper and zinc. Complex brasses contain additional alloying agents, such as aluminum, lead, iron, manganese, or phosphorus. Naval brass is a true brass containing about 60 percent copper, 39 percent zinc, and 1 percent tin added for corrosion resistance. It is used for propeller shafts, valve stems, and marine hardware.

Brass used by the Navy is classified as either leaded or unleaded, meaning that small amounts of lead may or may not be used in the copper-zinc mixture. Lead improves the machinability of brass.

**Bronze.**—Bronze is primarily an alloy of copper and tin, although several other alloying elements are added to produce special bronze alloys. Aluminum, nickel, phosphorous, silicon, and manganese are the most widely used alloying metals.

**Gunmetal.**—Gunmetal, a copper-tin alloy, contains approximately 86-89 percent copper, 7 1/2-9 percent tin, 3-5 percent zinc, 0.3 percent lead, 0.15 percent iron, 0.05 percent phosphorous, and 1 percent nickel. As you can see by the rather complex analysis of this bronze alloy, the term *copper-tin* is used only to designate the major alloying elements. Gunmetal bronze is used for bearings, bushings, pump bodies, valves, impellers, and gears.

**Aluminum Bronze.**—Aluminum bronze is actually a copper-aluminum alloy that does not contain any tin. It is made of 86 percent copper, 8 1/2-9 percent aluminum, 2 1/2-4 percent iron, and 1 percent of miscellaneous alloys. It is used for valve seats and stems, bearings, gears, propellers, and marine hardware.

**Copper-Nickel.**—Copper-nickel alloy is used extensively aboard ship because of its high resistance to saltwater corrosion. It is used in piping and tubing. In sheet form it is used to construct small storage tanks and hot water reservoirs. Copper-nickel alloy may contain either 70 percent copper and 30 percent nickel or 90 percent copper and 10 percent nickel. It

has the general working characteristics of copper but must be worked cold.

These and the many other copper alloys commonly used by the Navy have certain physical and mechanical properties (imparted by the various alloying elements) that cause one alloy to be more effective than another for a given application. Remember this if you go to the metal storage rack and select a bronze-looking metal without regard to the specific type. The part you make may fail prematurely in spite of the skill and attention to detail that you use to machine it.

**NICKEL ALLOYS.**—Nickel is a hard, malleable, and ductile metal. It is resistant to corrosion and therefore often is used as a coating on other metals. Combined with other metals, it makes a tough strong alloy.

**Nickel-Copper.**—Nickel-copper alloys are stronger and harder than either nickel or copper. They have high resistance to corrosion and are strong enough to be substituted for steel when corrosion resistance is of primary importance. Probably the best known nickel-copper alloy is Monel. It contains approximately 65 percent nickel, 30 percent copper, and small percentages of iron, manganese, silicon, and cobalt. Monel is used for pump shafts and internal parts, valve seats and stems, and many other applications requiring both strength and corrosion resistance.

**K-Monel.**—K-Monel is essentially the same as Monel except it contains about 3 percent aluminum and is harder and stronger than other grades of Monel. K-Monel stock is very difficult to machine. You can improve the metal's machinability considerably by annealing it immediately before machining. K-Monel is used for the shaft sleeves on many pumps because of its resistance to the heating and rubbing action of the packing.

There are several other nickel alloys that you may find in Navy equipment. Inconel; Inconel-X; and H, S, R, and KR Monel are a few of the more common alloys.

**ALUMINUM ALLOYS.**—Aluminum is being used more and more in ship construction because of light weight, easy workability, and good appearance. Pure aluminum is soft and not very strong. When alloying elements such as magnesium, copper, nickel, and silicon are added, however, a much stronger metal is produced.

Each of the aluminum alloys has properties developed specifically for a certain type of application. The hard aluminum alloys are easier to machine than the soft alloys and often are equal to low-carbon steel in strength.

**ZINC ALLOYS.**—Zinc is a comparatively soft, yet somewhat brittle, metal. Its tensile strength is only slightly greater than that of aluminum. Because of its resistance to corrosion, zinc is used as a protective coating for less corrosion-resistant metals, principally iron and steel.

Pure zinc has a strong anodic potential. It is used to protect the hulls of steel ships against electrolysis between dissimilar metals caused by electric currents set up by salt water. Zinc plates bolted on the hull, especially near the propellers, decompose quite rapidly, but greatly reduce localized pitting of the hull steel.

**TIN ALLOYS.**—Pure tin is seldom used except as a coating for food containers and sheet steel and in some electroplating applications. Several different grades of tin solder are made by adding either lead or antimony. One of the Navy's main uses of tin is to make bearing babbitt. About 5 percent copper and 10 percent antimony are added to 85 percent tin to make this alloy. Various grades of babbitt are used in bearings. Each grade may have additional alloying elements to give the babbitt the properties required.

**LEAD ALLOYS.**—Lead is probably the heaviest metal with which you will work. A cubic foot of it weighs approximately 700 pounds. It has a grayish color and is amazingly pliable. It is obtainable in sheets and pigs. The sheets normally are wound around a rod, and pieces can be cut off quite easily. One of the most common uses of lead is as an alloying element in soft solder.

## DESIGNATIONS AND MARKINGS OF METALS

You must understand the standard designations of metals and the systems of marking metals used by the Navy and industry so you can select the proper material for a specific job. There are several different numbering systems currently in use by different trade associations, societies, and producers of metals and alloys. You may find several different designations that refer to a metal with the same chemical composition, or several identical designations that refer to metals with different chemical compositions. The Society of Automotive Engineers, Inc. (SAE),

publishes *Unified Numbering System for Metals and Alloys*. It provides a clear and easily understood cross reference from the designation of one numbering system to other systems where a similar metal is involved. Some of the numbering systems that you may need to identify are as following:

Aluminum Association (AA)

American Iron and Steel Institute (AISI)

Society of Automotive Engineers (SAE)

Aerospace Materials Specifications (AMS)

American National Standards Institute (ANSI)

American Society of Mechanical Engineers (ASME)

American Society for Testing and Materials (ASTM)

Copper Development Association (CDA)

Military Specification (MIL-S-XXXX, MIL-N-XXXX)

Federal Specification (QQ-N-XX, QQ-S-XXX)

The Unified Numbering System lists all the different designations for a metal and assigns one number that identifies the metal. This system covers only the composition of the metal and not its condition, quality, or form. Use of the Unified Numbering System by the various metal producers is voluntary, and it could be some time before its use is widespread. Another useful publication is NAVSEA 0900-LP-038-8010, *Ship Metallic Material Comparison and Use Guide*.

The two major systems used for iron and steel are the Society of Automotive Engineers (SAE) and the American Iron and Steel Institute (AISI). The Aluminum Association method is used for aluminum and is discussed later in this chapter. Other nonferrous metals are designated by the percentage and types of elements in their composition. The Navy uses these methods to mark metals so they can be identified readily.

### Ferrous Metal Designations

You should be familiar with the SAE and AISI systems of steel classifications. These systems, which are in common use, have a four- or five-digit number to indicate the composition of the steel. The major difference between them is that the AISI system normally uses a letter before the numbers to show the

process used to make the steel, and the SAE system does not. The letters are *B*—acid Bessemer carbon steel; *C*—basic open-hearth or basic electric-furnace carbon steel; and *E*—electric-furnace alloy steel.

The first digit normally indicates the basic type of steel. Table 3-1 shows the SAE numbers with their corresponding alloying elements.

The second digit normally indicates a series within the group. The term *series* usually refers to the percentage of the major alloying element. Sometimes the second digit gives the actual percentage of the chief alloying element; in other cases, the second digit may indicate the relative position of the series in a group without reference to the actual percentage.

The third, fourth, and fifth digits indicate the average carbon content of the steel. If the carbon content is less than 1.00 you will have only four digits. The carbon content is expressed in points; for example: 2 points = 0.02 percent, 20 points = 0.20 percent, and 100 points = 1.00 percent. To make the various steels fit into this classification, it is sometimes necessary to vary the system slightly. However, you can easily understand such variations if you understand the system. Let's look at a few examples. Check them against the number in table 3-1.

(1) SAE 1035: The first digit is 1, so this is a carbon steel. The second digit, 0, shows there is no other important alloying element, so this is a PLAIN carbon steel. The next two digits, 35, show that the AVERAGE carbon content is 0.35 percent. There are also small amounts of other elements such as manganese, phosphorus, and sulfur.

(2) SAE 1146: This is a resulfurized carbon steel (often called free cutting steel). The first digit indicates a carbon steel. The second digit shows an average manganese content of 1.00 percent. The last two digits show an average carbon content of 0.46 percent. The amount of sulfur added to this steel ranges from 0.08 to 0.13 percent. Manganese and sulfur in this quantity make this series of steel one of the most easily machined steels available.

(3) SAE 4017: The first digit, 4, indicates that this is a molybdenum steel. The second digit, 0, indicates there is no other equally important alloying element, so this is a plain molybdenum steel. The last two digits, 17, show that the average carbon content is 0.17 percent.

**Table 3-1.—SAE Numbers with Their Corresponding Alloying Elements**

Type of Steel	SAE Number
Carbon Steels	1xxx
Plain carbon	10xx
Free cutting (screw lock)	11xx
High manganese	13xx
Nickel Steels	2xxx
3.50% nickel	23xx
5.00% nickel	25xx
Nickel-Chromium Steel	3xxx
1.25% nickel, 0.60% chromium	31xx
3.50% nickel, 1.50% chromium	33xx
Molybdenum Steels (0.25% molybdenum)	4xxx
1.0% chromium	41xx
0.5% chromium, 1.8% nickel	43xx
2% nickel	46xx
3.5% nickel	48xx
Chromium Steels	5xxx
Low chrome	51xx
Medium chrome	52xx
Chromium-Vanadium Steels	6xxx
Nickel-Chromium-Molybdenum (low amounts)	8xxx
Silicon-Manganese	92xx

Other series within the molybdenum steel group are identified by the second digit. If the second digit is 1, the steel is chromium-molybdenum steel; if the second digit is 3, the steel is a nickel-chromium-molybdenum steel; if the second digit is 6, the steel is a nickel-molybdenum steel. In such cases, the second digit does not indicate the actual percentage of the alloying elements, other than molybdenum.

(4) SAE 51100: This number identifies a chromium steel (first digit) with approximately 1.00 percent chromium (second digit) and an average carbon content of 1.00 percent (last three digits). The actual chromium content of SAE 51100 steels may vary from 0.95 to 1.10 percent.

(5) SAE 52100: This number identifies a chromium steel (first digit) of a higher alloy series (second digit) than the SAE 51100 steel just described. Note, however, that in this case the second digit, 2, merely identifies the series but does NOT show the percentage of chromium. A 52100 steel will actually have from 1.30 to 1.60 percent chromium

with an average carbon content of 1.00 percent (last three digits).

Navy blueprints and the drawings of equipment furnished in the manufacturers' technical manuals usually specify materials by federal or military specification numbers. For example, the coupling on a particular oil burner is identified as cast steel, class B, MIL-S-15083. This particular cast steel does not have a designation under any other metal identification systems because there are no chemically similar castings. On the other hand, a valve stem designated MIL-S-862, class 410 (a chromium stainless steel) may be cross referenced to several other systems. Some of the chemically similar designations for MIL-S-862, class 410 are as follows:

SAE = J405 (51410)

Federal Spec. = QQ-S-763(410)

AISI = 410

ASTM = A176(410)

ASM = 5504

ASME = SA194

*Unified Numbering System for Metals and Alloys* is a very useful book to use when cross referencing numbers.

**Table 3-2.—Aluminum and Aluminum Alloy Classifications**

Alloy	Percent of Aluminum	Numbers
Aluminum	99.00 percent pure	1xxx
Copper		2xxx
Manganese		3xxx
Silicon		4xxx
Magnesium		5xxx
Magnesium and Silicon		6xxx
Zinc		7xxx
Other		8xxx
Unused		9xxx

## Nonferrous Metal Designations

Nonferrous metals are generally grouped according to their alloying elements. Examples of these groups are brass, bronze, copper-nickel, and nickel-copper. Specific designations of an alloy are described by the amounts and chemical symbols of the alloying elements. For example, a copper-nickel alloy might be described as copper-nickel, 70 Cu-30 Ni. The 70 Cu represents the percentage of copper, and the 30 Ni represents the percentage of nickel.

The following list contains common alloying elements and their symbols:

- Aluminum . . . . . Al
- Carbon . . . . . C
- Chromium . . . . . Cr
- Cobalt . . . . . Co
- Copper . . . . . Cu
- Iron. . . . . Fe
- Lead . . . . . Pb
- Manganese . . . . . Mn
- Molybdenum . . . . . Mo
- Nickel . . . . . Ni
- Phosphorus . . . . . P
- Silicon . . . . . Si
- Sulphur . . . . . S
- Tin . . . . . Sn
- Titanium . . . . . Ti
- Tungsten . . . . . W
- Vanadium . . . . . V
- Zinc . . . . . Zn

In addition to the designations previously described, a trade name (such as Monel or Inconel) is sometimes used to designate certain alloys.

The Aluminum Association uses a four-digit designation system similar to the SAE/AISI system described for steels. The numerals assigned, with their meaning for the first digits of this system, are listed in table 3-2.

The first digit identifies the major alloying element, and the second digit indicates alloy



modifications or impurity limits. The last two digits identify the particular alloy or indicate the aluminum purity.

In the 1xxx group for 99.00 percent minimum aluminum, the last two digits show the minimum aluminum percentage to the right of the decimal point. The second digit shows modifications in impurity limits. If the second digit in the designation is zero, there is no special control on individual impurities. If the second digit is 1 through 9, it shows some special control of one or more individual impurities. As an example, 1030 indicates a 99.30 percent minimum aluminum without special control on individual impurities. Designations 1130, 1230, 1330, and so on, indicate the same purity with special control of one or more individual impurities.

Designations 2 through 8 are aluminum alloys. In the 2xxx through 8xxx alloy groups, the second digit indicates any alloy modification. The last two of the four digits identify the different alloys in the group.

In addition to the four-digit alloy designation, a letter or letter/number is included as a temper designation. This designation follows the four-digit alloy number and is separated from it by a dash. As an example, 2024-T6 is an aluminum-copper alloy solution. The T6 designation shows the metal is heat treated, then artificially aged; T6 is the temper designation. The following list contains the aluminum alloy temper designations and their meanings:

- F Fabricated
- O Annealed recrystallized (wrought only)
- H Strain hardened (wrought only)
  - H1, plus one or more digits, strain hardened only
  - H2, plus one or more digits, strain hardened, then partially annealed
  - H3, plus one or more digits, strain hardened, then stabilized
- W Solution heat treated, unstable temper
- T Treated to produce stable tempers other than F, O, or H
  - T2 Annealed (cast only)
  - T3 Solution heat treated, then cold worked
  - T4 Solution heat treated and naturally aged to a substantially stable condition

- T5 Artificially aged only
- T6 Solution heat treated, then artificially aged
- T7 Solution heat treated, then stabilized
- T8 Solution heat treated, cold worked, then artificially aged
- T9 Solution heat treated, artificially aged, then cold worked
- T10 Artificially aged, then cold worked

Note that some temper designations apply only to wrought products and others to cast products; but most apply to both. A second digit may appear to the right of the mechanical treatment. This second digit indicates the degree of hardening; 2 is 1/4 hard, 4 is 1/2 hard, 6 is 3/4 hard, and 8 is full hard. For example, the alloy 5456-H32 is an aluminum/magnesium alloy, strain hardened, then stabilized, and 1/4 hard.

### Standard Marking of Metals

Metals used by the Navy are usually marked by the producer with the continuous identification marking system. We'll explain the system in the following paragraphs. Do not depend only on the markings to be sure you are using the correct metal. Often, the markings will be worn off or cut off and you are left with a piece of metal you are not sure about. Additional systems, such as separate storage areas or racks for different types of metal or etching on the metal with an electric etcher could save you time later.

The continuous identification marking system, which is described in Federal Standards, is a means for positive identification of metal products even after some portions have been used. In this system, the markings are actually "printed" on the metal with a heavy ink that is almost like a paint, and they appear at intervals of not more than 3 feet. So, if you cut off a piece of bar stock, the remaining portions will still carry the proper identification. Some metals, such as small tubing, coils of wire, and small bar stock cannot be marked readily by this method. On these items, tags with the marking information are fastened to the metal.

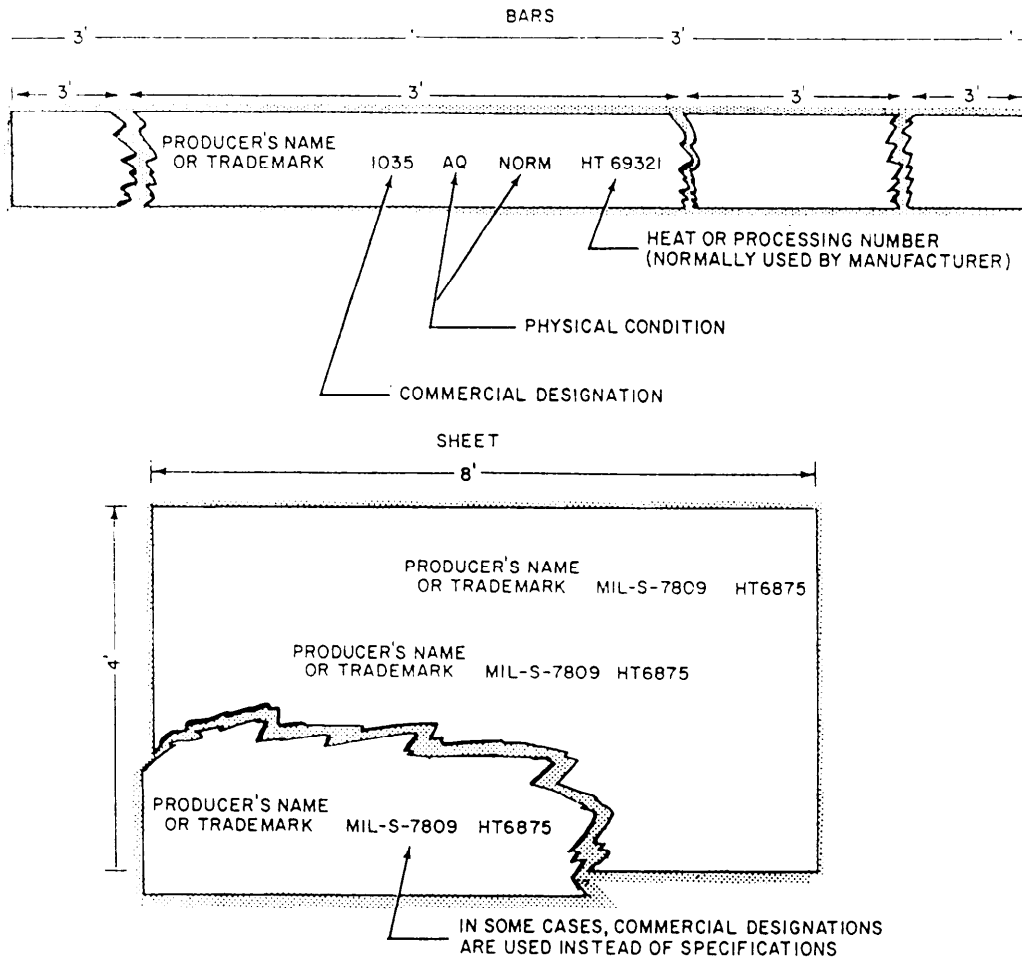


Figure 3-1.—Examples of continuous identification marking.

The manufacturer is required to make these markings on materials before delivery. The marking intervals for various shapes and forms are specified in the Federal Standard previously mentioned. Figure 3-1 shows the normal spacing and layout.

For metal products, the continuous identification marking must include (1) the producer's name or registered trademark and (2) the commercial designation of the material. In nonferrous metals the government specification for the material is often used. The producer's name or trademark shown is that of the producer who does the final processing or finishing before the material is marketed. The commercial designation includes the following information:

1. A material designation, such as an SAE number, an AISI number, or an ASTM (American Society of Testing Materials) specification
2. A "physical condition" and quality designation—that is, the designation of temper or other physical condition approved by a nationally

recognized technical society or industrial association, such as the American Iron and Steel Institute

Some of the physical conditions and quality designations for various metal products are as follows:

- CR . . . . . cold rolled
- CD . . . . . cold drawn
- HR . . . . . hot rolled
- AQ . . . . . aircraft quality
- CQ . . . . . commercial quality
- 1/4H . . . . . quarter hard
- 1/2H . . . . . half hard
- H . . . . . hard
- HTQ . . . . . high tensile quality
- AR . . . . . as rolled
- HT . . . . . heat treated
- G . . . . . ground

## IDENTIFICATION OF METALS

The various base metals, such as iron, copper, lead, zinc, and aluminum have certain identifying characteristics, such as surface appearance and weight. This helps persons who work with or handle these materials to distinguish one from another. There are, however, a number of related alloys that resemble each other and their base metal so closely that they defy accurate identification by simple means. You may have to send these metals to a shipyard for analysis.

There are other means of rapid identification of metals. These methods, however, do not provide positive identification and should not be used in critical situations where a specific metal is required. Some of the methods that we'll discuss here are magnet tests, chip tests, file tests, acid reaction tests, and spark tests. The latter two are most commonly used by the Navy and we'll discuss them in more detail. Table 3-3 contains information related to surface appearance, magnetic reaction, lathe chip test,

and file test. When you perform these tests, you should compare the unknown metal with a known sample of some metal. You also will need good lighting, a strong permanent magnet, and access to a lathe. A word of caution: when you perform these tests, **DO NOT** be satisfied with the results of only one test. Use as many tests as possible so you can increase the chances of an accurate identification.

### Spark Test

Spark testing is the identification of a metal by observing the color, size, and shape of the spark stream given off when you hold the metal against a grinding wheel. This method of identification is adequate for most machine shop purposes. When you must know the exact composition of a metal, make a chemical analysis. You need a lot of experience before you can identify metals by a spark test. To gain this experience, you'll need to practice by comparing the spark stream of unknown specimens

Table 3-3.—Rapid Identification of Metals

Metal	Surface Appearance or markings	Reaction to a Magnet	Lathe Chip test	Color of freshly filed surface
White cast iron	Dull gray	Strong	Short, crumbly chips	Silvery white
Gray cast iron	Dull gray	Strong	Short, crumbly chips	Light silvery gray
Aluminum	Light gray to white dull or brilliant	None	Easily cut, smooth long chips	White
Brass	Yellow to green or brown	None	Smooth long chips slightly brittle	Reddish yellow to yellowish white
Bronze	Red to brown	None	Short crumbly chips	Reddish yellow to yellowish white
Copper	Smooth; red brown to green (oxides)	None	Smooth long pliable chips	Bright copper color
Copper-nickel	Smooth; gray to yellow or yellowish green	None	Smooth, continuous chips	Bright silvery white
Lead	White to gray; smooth, velvety	None	Cut by knife, any shape chip	White
Nickel	Dark gray; smooth; sometimes green (oxides)	Medium	Cuts easily, smooth continuous chip	Bright silvery white
Nickel-copper	Dark gray, smooth	Very slight	Continuous chip; tough to cut	Light gray
Plain carbon steel	Dark gray; may be rusty	Strong	Varies depending upon carbon content	Bright silvery gray
Stainless steel (18-8) (25-20) "Note 1 below"	Dark gray; dull to brilliant; usually clean	None (faint if severely cold worked)	Varies depending upon heat treatment	Bright silvery gray
Zinc	Whitish blue, may be mottled	None	Easily cut; long stringy chips	White

1. Stainless steels that have less than 26 percent alloying elements react to magnet.

with that of known specimens. Many shops maintain specimens of known composition for this purpose.

Proper lighting conditions are essential for good spark testing. You should perform the test in an area where there is enough light, but no harsh or glaring light. You may find that many shops have a spark test cabinet. Generally, these cabinets consist of a box with a dark, painted interior, mounted on top of a workbench. A bench grinder is mounted inside the cabinet. Test specimens of known composition are stored in shelves at the end of the cabinet. Where possible, the testing area should be away from heavy drafts of air. Drafts can change the tail of the spark stream and may result in improper identification. Generally speaking, a suitable grinding wheel for spark testing is an 8-inch wheel of 30 to 60 grains turning at 3,600 rpm. This provides a surface speed of 7,537 feet per minute.

The speed of the grinding wheel and the pressure you exert on the samples greatly affect the spark test. The faster the speed of the wheel, the larger and longer the spark stream. The pressure of the piece against the wheel has a similar effect: the more pressure you apply to the test piece, the larger and longer the spark stream. Hold the test piece lightly but firmly against the wheel with just enough pressure to prevent the piece from bouncing. Remember, you must apply the same amount of pressure to the test specimen as to the sample you are testing.

Be sure to keep the wheel clean at all times. A wheel loaded with particles of metal will give off a spark stream of the type of metal in the wheel mixed with the spark stream of the metal being tested. This can confuse you and prevent you from properly identifying the metal. Dress the wheel before you begin spark testing and before each new test of a different metal.

To do a spark test, hold a sample of the material against a grinding wheel. The sparks given off, or the lack of sparks, help you identify the metal. Look for the length of the spark stream, its color, and the type of sparks.

Figure 3-2 shows the four fundamental spark forms. View A shows shafts, buds, breaks, and arrows. The arrow or spearhead is characteristic of molybdenum, a metallic element of the chromium group that resembles iron and is used to form steel-like alloys with carbon. The swelling, or buds, in the spark line indicate nickel with molybdenum. View B shows shafts and sprigs, or sparklers, that

indicate a high carbon content. View C shows shafts, forks, and sprigs that indicate a medium carbon content. View D shows shafts and forks that indicate a low carbon content.

The greater the amount of carbon in a steel, the greater the intensity of bursting in the spark stream. To understand the cause of the bursts, remember that while the spark is glowing, the carbon in the particle contacts oxygen in the air and is burned to carbon dioxide ( $\text{CO}_2$ ). The  $\text{CO}_2$  in the gaseous state increases in volume and builds up pressure that is relieved by explosions of the particles. If you examine the small steel particles under a microscope when they are cold, you'll see they are hollow spheres with one end completely blown away.

Steels with the same carbon content but different alloying elements are not always easily identified because alloying elements affect the carrier lines, the bursts, or the forms of characteristic bursts in the spark picture. The effect of the alloying element may retard or accelerate the carbon spark or make the carrier line lighter or darker in color. Molybdenum, for example, appears as a detached, orange-colored, spearhead on the end of the carrier line. Nickel seems to suppress the effect of the carbon burst. But, the

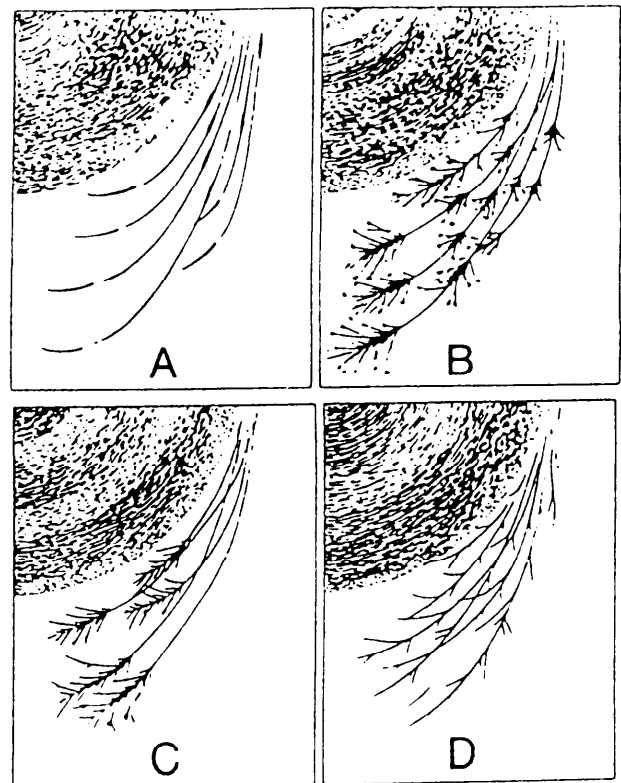


Figure 3-2.—Fundamental spark forms.

nickel spark can be identified by tiny blocks of brilliant white light. Silicon suppresses the carbon burst even more than nickel. When silicon is present, the carrier line usually ends abruptly in a flash of white light.

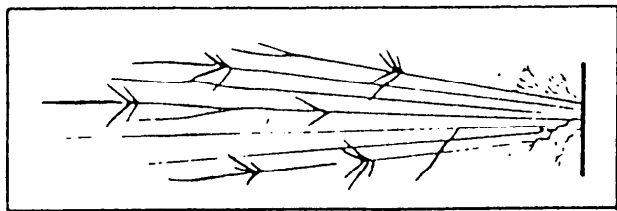
To make the spark test, hold the piece of metal on the wheel so you throw the spark stream about 12 inches at a right angle to your line of vision. You'll need to spend a little time to learn at just what pressure you must hold the sample to get a stream of this length without reducing the speed of the grinder. Don't press too hard because the pressure will increase the temperature of the spark stream and the burst. It also will give the appearance of a higher carbon content than that of the metal being tested.

After practicing, select a couple of samples of metal with widely varying characteristics; for example, low-carbon steel and high-carbon steel. Hold first one and then the other against the wheel. Always touch the same portion of the wheel with each

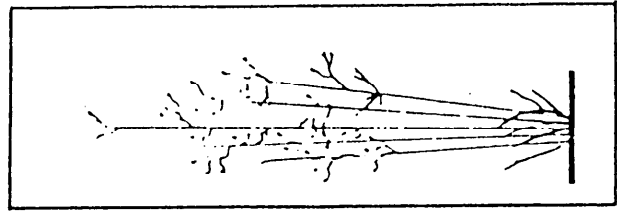
piece. With your eyes focused at a point about one-third the distance from the tail end of the stream of sparks, watch only those sparks that cross your line of vision. You'll find that after a little while you will form a mental image of an individual spark. After you can fix the spark image in mind, you are ready to examine the whole spark picture.

In the sample of low-carbon steel, notice that the spark stream is long (about 70 inches) and the volume is moderately large. The few sparklers that may occur are forked. In the sample of high-carbon steel, the stream is shorter (about 55 inches) and large in volume. The sparklers are small and repeating, and some of the shafts may be forked.

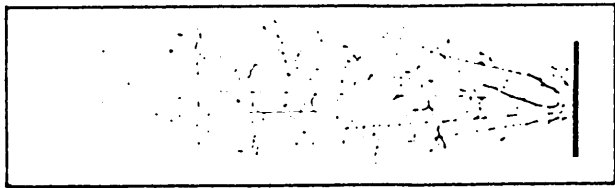
White cast iron produces a spark stream about 20 inches long (see fig. 3-3). The volume of sparks is small with many small, repeating sparklers. The color of the spark stream close to the wheel is red, while the outer end of the stream is straw-colored.



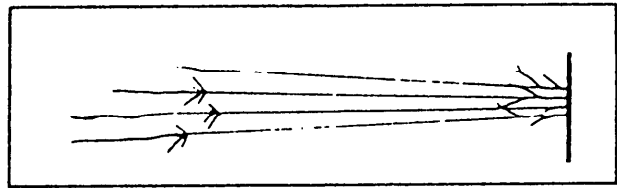
LOW CARBON AND CAST STEEL



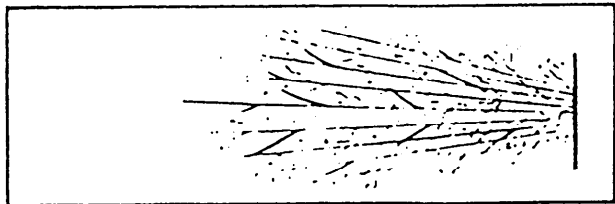
MALLEABLE IRON



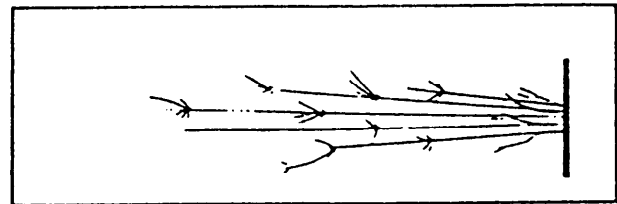
GRAY CAST IRON



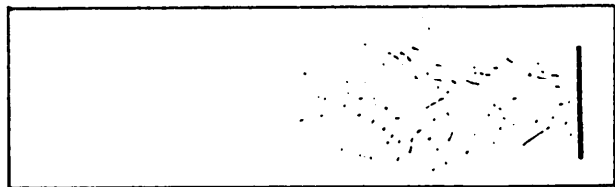
WROUGHT IRON



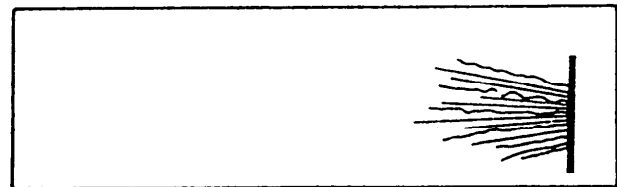
HIGH CARBON STEEL



STAINLESS STEEL



WHITE CAST IRON



NICKEL

Figure 3-3.—Spark pictures formed by common metals.

Gray cast iron produces a spark stream about 25 inches long. It is small in volume with fewer sparklers than white cast iron. The sparklers are small and repeating. Part of the stream near the grinding wheel is red, and the outer end of the stream is straw-colored.

The malleable iron spark test will produce a spark stream about 30 inches long. It is of moderate volume with many small, repeating sparklers toward the end of the stream. The entire stream is straw-colored.

The wrought iron spark test produces a spark stream about 65 inches long. It has a large volume with few sparklers. The sparklers show up toward the end of the stream and are forked. The stream next to the grinding wheel is straw-colored, while the outer end of the stream is a bright red.

Stainless steel produces a spark stream about 50 inches long, of moderate volume, and with few sparklers. The sparklers are forked. The stream next to the wheel is straw-colored, and white at the end.

Nickel produces a spark stream only about 10 inches long. It is small in volume and orange in color. The sparks form wavy streaks with no sparklers.

Monel forms a spark stream almost identical to that of nickel and must be identified by other means. Copper, brass, bronze, and lead form no sparks on the grinding wheel, but you can identify them by other means, such as color, appearance, and chip tests.

You'll find the spark tests easy and convenient. They require no special equipment and are adaptable to most any situation. Here again, experience is the best teacher.

### **Acid Test**

When you need to identify metal quickly, the nitric acid test is the most common and easiest test used in the Navy today, but you can use it only in noncritical situations. It requires no special training in chemistry. It is most helpful in distinguishing between stainless steel, Monel, copper-nickel, and carbon steels. Whenever you perform an acid test, be sure to observe all safety precautions.

To perform the nitric acid test, place one or two drops of concentrated (full strength) nitric acid on a metal surface that has been cleaned by grinding or filing. Observe the resulting reaction (if any) for about 2 minutes. Then, add three or four drops of water, one drop at a time, and continue observing the reaction. If there is no reaction at all, the test material

may be one of the stainless steels. A reaction that produces a brown-colored liquid indicates a plain carbon steel. A reaction that produces a brown to black color indicates a gray cast iron or one of the alloy steels with its principal element either chromium, molybdenum, or vanadium. Nickel steel reacts to the acid test by forming a brown to greenish-black liquid. A steel containing tungsten reacts slowly to form a brown-colored liquid with a yellow sediment.

You get a different result when you do an acid test on nonferrous metals and alloys. As the material dissolves you'll see shades of green and blue instead of the brown-black colors that usually appear on ferrous metals. Except on nickel and Monel, the reaction is vigorous. Nickel's reaction to nitric acid proceeds slowly and develops a pale green color. On Monel the reaction takes place at about the same rate as on ferrous metals, but the characteristic color of the liquid is greenish-blue. Brass reacts vigorously, and the test material changes to a green color. Tin bronze, aluminum bronze, and copper all react vigorously and the liquid changes to a blue-green color. Aluminum and magnesium alloys, lead, lead-silver, and lead-tin alloys are soluble in nitric acid, but the blue or green color is lacking.

It's easy to see that you'll need good visual skill to identify the many different reactions of metals to nitric acid. Acid test kits are available containing several different solutions to identify the different metals. Some of the kits can identify between the different series of stainless steel (300, 400 series). They also can quickly identify low-alloy steels, nickel steels, and various bronze alloys. All large repair shops and shore repair facilities have a NON DESTRUCTIVE TEST (NDT) laboratory. The personnel assigned to them will help you to identify various metals in more critical situations, or when you need a greater accuracy on a repair job.

### **PLASTICS**

Plastic materials are increasingly being used aboard ship. In some respects, they tend to surpass structural metals. Plastic is shock resistant, not susceptible to saltwater corrosion, and in casting, lends itself to mass production and uniformity of end product.

## CHARACTERISTICS

Plastics are formed from organic materials, generally with some form of carbon as their basic element. Plastics are synthetic materials, but they are not necessarily inferior to natural material. On the contrary, they have been designed to perform particular functions that no natural material can perform. Plastics come in a variety of colors, shapes, and forms. Some are as tough, but not as hard, as steel; some are as pliable as rubber; some are more transparent than glass; and some are lighter than aluminum.

Plastic materials fall into two major divisions—**THERMOSETTINGS** and **THERMOPLASTICS**. It's necessary to know which one you are using if you are going to perform any kind of shopwork on plastics.

Thermosettings are tough, brittle, and heat hardened. When placed in a flame, they will not burn readily, if at all. Thermosettings are so hard that they resist the penetration of a knife blade; any such attempt will dull the blade. If the plastic is immersed in hot water and allowed to remain, it will neither absorb moisture nor soften.

Thermoplastics, on the other hand, become soft and pliable, or even melt when they are exposed to heat. When cooled, they retain the shape they took under the application of heat. Some thermoplastics will even absorb a small amount of moisture, if they are placed in hot water. A knife blade will cut easily into thermoplastics.

When you test a plastic by inserting it into a fire, be careful, because thermoplastics will burst into sudden intense flame and give off obnoxious gases. If you use the fire test, be sure to hold the plastic piece well away from you.

## MAJOR GROUPS

You don't need to know the exact chemical composition of the many plastics in existence. But, it will help if you have a general idea of the composition of the plastics you are most likely to use. Table 3-4 provides information on some groups of plastics that a machinery repairman may use.

Laminated plastics are made by dipping, spraying, or brushing flat sheets or continuous rolls of paper, fabric, or wood veneer with resins, and then pressing several layers together to get hard, rigid, structural material. The number of layers that will be

pressed into one sheet depends upon the thickness wanted. The end care of the product dictates the choice of paper, canvas, wood veneer, or glass fabric. Paper-based material is thin and quite brittle and it breaks if it's bent sharply, but canvas-based material is difficult to break. As layers are added to paper-based material, it gains in strength, but it's never as tough and strong in a laminated part as layers of glass fabric or canvas.

Laminated materials are widely used aboard ship. For example, laminated gears are used on internal-combustion engines, usually as timing or idler gears; on laundry equipment; and on certain pumps. In comparison with metal gears, plastic gears are quieter in operation, pick up less heat when friction is generated, and wear longer.

Plastics are identified by several commercial designations, by trade names, and by military and federal specifications. There is such a large number of types, grades, and classes of plastics within each major group that you cannot rely only on the recognition of a trade. Use the appropriate federal supply catalog to cross reference the military (MIL-P-XXXX) or federal (FED-L-P-XXXX) designations to the correct procuring data for the Federal Supply System.

## MACHINING OPERATIONS

Since machining operations on plastics call for you to cut parts from sheet or rod stock, use various metal-cutting saws; remove stock from parts by rotating tools as in a drill press or a milling machine; cut moving parts with stationary tools, as on a lathe; and do finishing operations.

### Sawing

You can use several types of saws—bandsaw, jigsaw, circular saw—to cut blanks from plastic stock. Watch the saw speed carefully. Since the plastic will not carry away most of the heat generated, there is always danger that the tool will overheat to the point that it will burn the work.

### Drilling

In drilling plastics, back the drill out frequently to remove the chips and cool the tool. A liberal application of coolant will help keep the drill cool. To get a smooth, clean hole, use paraffin wax on the drill.

Table 3-4.—Major Groups of Plastic

Plastic Trade Names in ( )	Advantages and Examples of Uses	Disadvantages
<b>THERMOPLASTICS</b>		
Acrylic (Lucite, Plexiglass)	Formability; good impact strength; good aging and weathering resistance; high transparency, shatter-resistance, rigidity. Used for lenses, dials, etc.	Softening point of 170° to 220° F; low scratch resistance.
Cellulose nitrate (Celluloid)	Ease of fabrication; relatively high impact strength and toughness; good dimensional stability and resilience; low moisture absorption. Used for tool handles, mallet heads, clock dials, etc.	Extreme flammability; poor electrical insulating properties; harder with age; low heat distortion point.
Polyamide (Nylon)	High resistance to distortion under load at temperatures up to 300° F; high tensile strength, excellent impact strength at normal temperatures; does not become brittle at temperatures as low as minus 70° F; excellent resistance to gasoline and oil; low coefficient of friction on metals. Used for synthetic textiles, special types of bearings, etc.	Absorption of water; large coefficient of expansion; relatively high cost; weathering resistance poor.
Polyethylene (Polythene)	Inert to many solvents and corrosive chemicals; flexible and tough over wide temperature range, remains so at temperatures as low as minus 100° F; unusually low moisture absorption and permeability; high electrical resistance; dimensionally stable at normal temperatures; ease of molding; low cost. Used for wire and cable insulation, and acid resistant clothing.	Low tensile, compressive, flexural strength; very high elongation at normal temperatures; subject to spontaneous cracking when stored in contact with alcohols, toluene, and silicone grease, etc.; softens at temperatures above 200° F; poor abrasion and cut resistance; cannot be bonded unless given special surface treatment.



Table 3-4.—Major Groups of Plastic—Continued

Plastic Trade Names in ( )	Advantages and Examples of Uses	Disadvantages
Polytetrafluoroethylene (Teflon)	<p style="text-align: center;"><b>THERMOPLASTICS</b></p> <p>Extreme chemical inertness; high heat resistance; nonadhesive; tough; low coefficient of friction. Used for preformed packing and gaskets.</p>	<p>Not easily cemented; cannot be molded by usual methods; generates toxic fumes at high temperatures; high cost.</p>
Phenolformaldehyde (Bakelite, Durez, Resinox)	<p style="text-align: center;"><b>THERMOSETTING PLASTICS</b></p> <p>Better permanence characteristics than most plastics; may be used at temperatures from 250° to 475°F; good aging resistance; good electrical insulating properties; not readily flammable, does not support combustion; inserts can be firmly embedded; strong, light; low water absorption; low thermal conductivity; good chemical resistance; economical in production of complex shapes; free from cold flow; relatively insensitive to temperature; low coefficient of thermal expansion; no change in dimensions under a load for a long time; does not soften at high temperatures or become brittle down to minus 60°F; inexpensive. Used for handles, telephone equipment, electrical insulators, etc.</p>	<p>Difficult to mold when filled for greatest impact strength, or when in sections less than 3/32-inch thick; can be expanded or contracted by unusually wet or dry atmosphere.</p>
Urea-formaldehyde (Beetle, Bakelite Urea, Plaskon)	<p>High degree of translucency and light finish; hard surface finish; outstanding electrical properties when used within temperature range of minus 70° to plus 170°F; complete resistance to organic solvents; dimensionally stable under moderate loadings and exposure conditions. Used for instrument dials, electric parts, etc.</p>	<p>Low impact strength; slight warping with age; poor water resistance.</p>

## **Lathe Operations**

Lathe operations are about the same for plastics as for metals. The difference is in the type of tool and the manner in which it contacts the work. For plastics, set the tool slightly below center. Use cutting tools with zero or slightly negative back rake.

For both thermosettings and thermoplastics, recommended cutting speeds are 200 to 500 fpm with high-speed steel tools and 500 to 1,500 fpm with carbide-tipped tools.

## **Finishing Operations**

Plastics must be finished to remove tool marks and produce a clean, smooth surface. Usually, sanding and buffing are sufficient for this purpose.

You can remove surface scratches and pits by hand sandpapering with dry sandpaper of fine grit. You also can wet-sand by hand, with water and abrasive paper of fine grade. If you need to remove a large amount of material, use sanding wheels or disks.

After you have removed the pits and scratches, buff the plastic. You can do this on a wheel made of loose muslin buffs. Use rouge buffing compounds, and deposit a layer of the compound on the outside of the buffing wheel. Renew the compound frequently.

When you buff large, flat sheets, don't use too much pressure, and don't hold the work too long in one position. When buffing small plastic parts, be careful that the wheel does not seize the piece and pull it out of your grasp.

## CHAPTER 4

# POWER SAWS AND DRILLING MACHINES

### CHAPTER LEARNING OBJECTIVES

*Upon completing this chapter, you should be able to do the following:*

- *Identify and explain the use of power saws.*
- *Identify and explain the use of drilling machines.*
- *Explain the use of twist drills.*

A machine tool is a power driven machine that holds the material and cutting tool and brings them together so the material is drilled, cut, shaved or ground. Chapter 1 covered common handtools. In this chapter we will deal primarily with power saws and drilling machines.

### POWER SAWS

Before we discuss the operation of power saws, you must realize the importance of observing safety precautions. Carelessness is one of the prime causes of accidents in the machine shop. Moving machinery is always a potential danger. When this machinery is associated with sharp cutting tools, the hazard is greatly increased. As with any shop equipment you must observe all posted safety precautions. Review your equipment operators manual for safety precautions and any chapters of *Navy Occupational Safety and Health (NAVOSH) Program Manual for Forces Afloat*, OPNAV Instruction 5100.19B, that pertain to the equipment.

### POWER HACKSAW

The power hacksaw is found in many Navy machine shops. It is used to cut bar stock, pipe, tubing, or other metal stock. The power hacksaw consists of a base, a saw frame, and a work holding device. Figure 4-1 shows a standard power hacksaw.

The base consists of a reservoir to hold the coolant, a coolant pump, the drive motor and a transmission for speed selection. Some models may have the feed mechanism attached to the base.

The saw frame consists of linkage and a circular disk with an eccentric (off center) pin designed to convert circular motion into reciprocating motion. The blade is inserted between the two blade holders and securely attached by either hardened pins or socket head screws. The inside blade holder is adjustable. This adjustable blade holder allows the correct tension to be put on the blade to ensure that it is held rigidly enough to prevent it from wandering and causing a slanted cut. The feed control

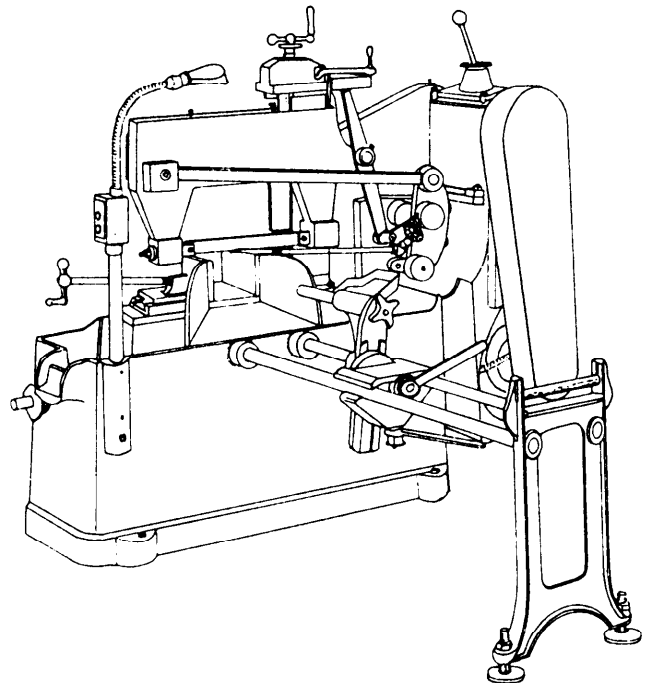


Figure 4-1.—Standard power hacksaw.

mechanism is also attached to the saw frame on many models.

The work holding device is normally a vise with one stationary jaw and one movable jaw. The movable jaw is mounted over a toothed rack to permit a rapid and easy initial adjustment close to the material to be cut. Do final tightening by turning the vise screw until the material is held securely. An adjustable stop permits pieces of the same length to be cut without measuring each piece separately. A stock support stand (available for both sides of the saw) keeps long stock from falling when being cut.

The power hacksaw illustrated can handle material up to 4 inches wide and 4 inches thick.

### Blade Selection

The blade shown in figure 4-2 is especially designed for use with the power hacksaw. It is made with a tough alloy steel back and high-speed steel teeth. This combination gives a strong blade and cutting edge suitable for high-speed sawing.

These blades differ by the pitch of the teeth (number of teeth per inch). You should select the correct pitch of teeth for a particular job according to the size and material composition of the section to be cut. Use coarse pitch teeth for wide, heavy sections to provide ample chip clearance. For thinner sections, use a blade with a pitch that keeps two or more teeth in contact with the work so that the teeth do not straddle the work. Straddling strips the teeth from the blade. In general, select blades according to the following information:

- Coarse (4 teeth per inch), for soft steel, cast iron, and bronze.
- Regular (6 to 8 teeth per inch), for annealed high carbon steel and high-speed steel.
- Medium (10 teeth per inch), for solid brass stock, iron pipe, and heavy tubing.
- Fine (14 teeth per inch), for thin tubing and sheet metals.

### Coolant

You should use a coolant for most power hacksawing operations. (Cast iron can be sawed dry.) The coolant keeps the kerf (narrow slot created by the cutting action of the blade) clear of chips so that the blade does not bind up and start cutting crooked. The

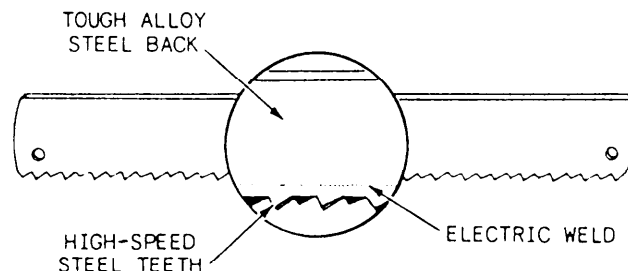


Figure 4-2.—Hacksaw blade.

coolant protects the teeth from overheating. This allows you to increase the rate of cutting beyond the speed possible without coolant. A soluble oil solution with a mixture of the oil and water will be suitable for most sawing operations. The normal mixture for soluble oil is 40 parts water to 1 part oil. You also may use a synthetic coolant.

### Feeds and Speeds

A power hacksaw will have one of three types of feed mechanisms:

- Mechanical feed, which ranges from 0.001 to 0.025 inch per stroke, depending upon the class and type of material being cut
- Hydraulic feed, which exerts a constant pressure but is designed so that the feed is automatically stopped or shortened at hard spots to decrease the pressure on the saw until the hard spot has been cut through
- Gravity feed, in which weights are placed on the saw frame and shifted to give more or less pressure of the saw blade against the material being cut

To prevent unnecessary wear on the back sides of the saw blade teeth, the saw frame and blade are automatically raised clear of the surface being cut on each return stroke. The rate of feed or the pressure exerted by the blade on the cutting stroke depends on several factors—the toughness and hardness of the material, the size, and in the case of a hollow pipe, the wall thickness. You must cut a hard, large diameter piece of stock with a slower or lighter feed rate than you would use with a soft, small diameter piece of stock. Cut pipe with thin walls with a relatively light feed rate. This prevents stripping the teeth from the saw blade or collapsing the walls of the pipe. A feed rate that is too heavy or fast will often cause the saw blade to wander, producing an angled cut.

The speed of hacksaws is stated in strokes per minute, counting only those strokes on which the blade comes in contact with the stock. You will use a gear lever to change speeds. There may be a chart attached to or near the saw, giving recommended speeds for cutting various metals. You may use the following speeds:

- Medium and low carbon steel, brass, and soft metals—136.
- Alloy steel, annealed tool steel, and cast iron—90.
- Unannealed tool steel, and stainless steel—60.

### **Saw Operation**

A power hacksaw is relatively simple to operate. There are, however, a few checks you should make to ensure good cuts. Support overhanging ends of long pieces to prevent sudden breaks at the cut before the

work is completely cut through. Block up irregular shapes so that the vise holds firmly. Check the blade to be sure it is sharp and that it is secured at the proper tension.

Place the workpiece in the clamping device, adjusting it so the cutting off mark is in line with the blade. Turn the vise lever to clamp the material in place. Be sure the material is held firmly.

See that the blade is not touching the workpiece when you start the machine. You often break blades when you don't follow this rule. Feed the blade slowly into the work, and adjust the coolant nozzle so that it directs the fluid over the saw blade.

### **CONTINUOUS FEED CUTOFF SAW**

Figure 4-3 illustrates a type of cutoff saw that is now being used in most shops throughout the Navy. There are different models of this saw, but the basic design and operating principles remain the same.

Deleted—No permission  
granted for electronic copy.

**Figure 4-3.—Continuous feed cutoff saw.**

Figure 4-4.—Control panel (DoAll saw).

### Band Selection and Installation

The bands for the continuous feed cutoff saw are nothing more than an endless hacksaw blade. With this thought in mind, you can see that all the factors that were discussed for power hacksaw blade selection can be applied to this saw. This saw is also equipped with a job selector (fig. 4-3) to help you make the proper selection. The bands come in two different forms; ready made loops of the proper length and coils of continuous lengths of 100 feet or more. You may not change the presized band, but you must cut the coils of saw bands to the proper length and then butt-welded the ends. (Butt welding is covered later in this chapter.) Once you have selected the saw band, install it following the instructions in your saws operators manual.

### Saw Operation

You will control the movement of the saw head from the control panel (fig. 4-4). Once you are ready to operate the saw follow these steps:

1. Pull the hydraulic start button (this will pressurize both the hydraulic and coolant systems).
2. Adjust the vice for work size and workstop for the desired cut-off length. Place it's band speed, feed and coolant at approximate settings.
3. Raise the head with the head control joy stick, then set the control on "hold".
4. Position the workpiece and clamp the vice.

5. Pull the "Band Start" button and turn the head control to the "saw" position to start the cut. Adjust coolant, band speed, and feed if necessary.
6. The machine stops automatically at the end of the cut.

### METAL CUTTING BANDSAWS

Metal cutting bandsaws are standard equipment in repair ships and shore repair facilities. You can use these machines for nonprecision cutting similar to power hacksaws. You can use some types for precision cutting, filing, and polishing. A bandsaw is more flexible for straight cutting than a power hacksaw in that it can cut objects of any reasonable size and of regular and irregular shapes.

Figure 4-5 illustrates a metal cutting bandsaw with a tiltable table. On the type shown, you should feed the work either manually or by power to the blade which runs in a fixed position.

The tiltable band saw is particularly suited to straight and angle cuts on large, long, or heavy pieces.

The tiltable table is convenient for contour cutting because you can quickly change the angle at which you feed work to the blade. This machine usually has special attachments and accessories to make precision inside or outside cuts of contours and disks and to miter. It has special bands to file and polish work. The saw bands, file bands, and polishing bands used on these machines are called BAND TOOLS, and the machine itself is often referred to as a BAND TOOL MACHINE. We have listed some definitions that will

Deleted—No permission granted for electronic copy.

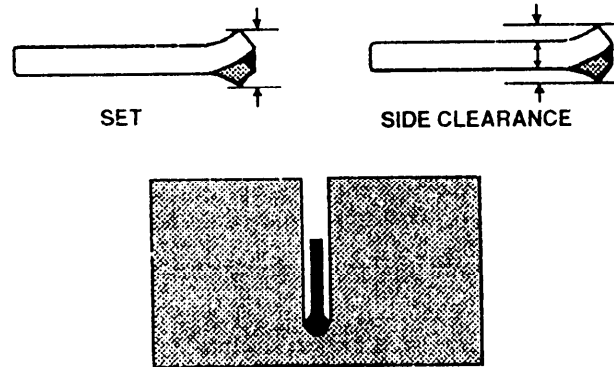


Figure 4-7.—Set and side clearance.

**SET:** The bend or spread given to the teeth to provide clearance for the body or band back when you make a cut.

**SIDE CLEARANCE:** The difference between the dimension of the band back (gauge) and the set of the teeth. Side clearance provides running room for the band back in the kerf or cut. Without side clearance, a band will bind in the kerf.

Figure 4-5.—Tiltable (contour) metal-cutting bandsaw.

help you understand band tool terminology for saws, files, and polishing bands.

### Saw Bands

A saw band has the following characteristics which are illustrated in figures 4-6 through 4-8.

**PITCH:** The number of teeth per linear inch.

**WIDTH:** The distance across the flat face of the band. The width measurement is always expressed in inches, or fractions of an inch.

**GAUGE:** The thickness of the band back. This measurement is expressed in thousandths of an inch.

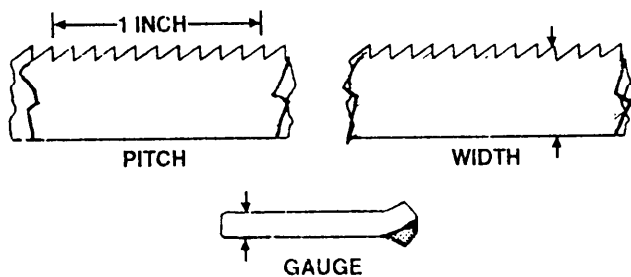


Figure 4-6.—Pitch, width, and gauge.

**SET PATTERN:** One of three distinct patterns (raker, wave, and straight) in which teeth are set. Raker set bands are generally used for solid cross section work. Wave set bands are used to cut hollow materials, such as pipe and tubing, and for other work where there is a great deal of variation in thickness. Straight set bands are not used to any great extent to cut metal.

**TEMPER:** The degree of hardness of the teeth, indicated by the letters A and B, temper A being the harder. Temper A bands are used for practically all bandsaw metal cutting work.

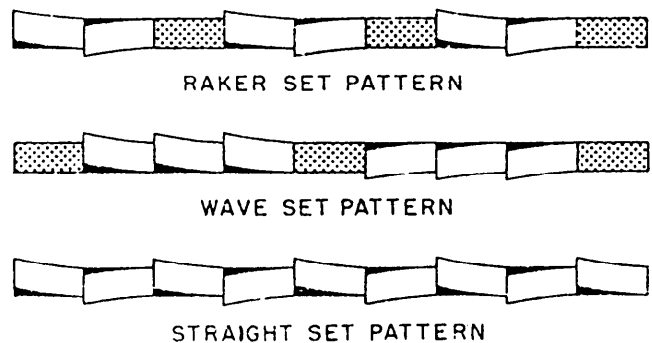


Figure 4-8.—Set pattern.

Deleted—No permission  
granted for electronic copy.

**Figure 4-9.—File band flexing principle and construction.**

### **File Bands**

A file band consists of a long steel strip that has a number of file segments mounted on it. It can be flexed around the band wheels and still present a straight line at the point of work. Figure 4-9 shows the file band flexing principle and the construction of a file band.

guide is in a fixed position under the work table, and the upper guide is attached to a vertically adjustable arm above the table which permits you to raise or lower the guide to suit the height of work. To obtain adequate support for the band and yet not interfere

### **Polishing Bands**

Abrasive coated fabric bands are used for grinding and polishing operations in a band tool machine. They are mounted in the same way as saw and file bands. Figure 4-10 shows a polishing band. Figure 4-11 shows a backup support strip being installed, before the polishing band is installed.

Deleted—No permission  
granted for electronic copy.

### **Band Tool Guides**

As an MR you will primarily use three types of band tool guides. They are saw band guides, file band guides and polishing band guides.

**SAW BAND GUIDES.**—The upper and lower guides keep the saw band in its normal track when when you apply work pressure to the saw. The lower

**Figure 4-10.—Polishing band.**



Deleted—No permission granted for electronic copy.

Deleted—No permission granted for electronic copy.

**Figure 4-13.—File band guide.**

type. Note in both types the antifriction bearing surface for the band's relatively thin back edge. This feature allows the necessary work pressure to be placed on the saw without causing serious rubbing and wear. Be sure to lubricate the bearings of the guide rollers according to the manufacturer's recommendations.

**Figure 4-11.—Installing a backup support strip for polishing band.**

with the sawing operation, place the upper guide so that it will clear the top of the workpiece by 1/8 to 3/8 of an inch. Figure 4-12 shows the two principal types of saw band guides: the insert type and the roller

**FILE BAND AND POLISHING BAND GUIDES.**—For band filing operations, replace the regular saw band guide with a flat, smooth-surface metal backup support strip, as shown in figure 4-13.

Deleted—No permission granted for electronic copy.

**Figure 4-12.—Saw band guides.**

This prevents sagging of the file band at the point of work. Use a similar support for a polishing band. This support has a graphite-impregnated fabric face that prevents undue wear on the back of the polishing band, which also is fabric.

### **Selection Of Saw Bands, Speeds And Feeds**

Saw bands are available in widths ranging from 1/16 to 1 inch; in various even-numbered pitches from 6 to 32; and in three gauges—0.025, 0.032, and 0.035 inch. The gauge of saw band that can be used in any particular machine depends on the size of the band wheels. You cannot successfully use a thick saw band on a machine that has small diameter bandwheels; therefore, only one or two gauges of blades may be available for some machines. Generally, only temper A, raker set, and wave set bands are used to cut metal.

Saw bands come in different forms for different working. Some are furnished in ready made loops of the correct length. Others come in coils of 100 feet or more from which you must cut a length and form it into a band loop by butt welding the ends together in a special machine. Later in this chapter, we will explain the process of joining the ends and installing bands.

Band tool machines have a multitude of band speeds, ranging from about 50 feet per minute to about 1500 feet per minute. Most of them are equipped with a hydraulic feed which provides three feeding pressures: low, medium, and heavy.

Success in precision sawing with's metal cutting bandsaw depends on several factors: You must select the correct saw blade or band, you must run the saw band at the correct speed, and you must feed the work to the saw at the correct rate. Many band tool machines have a job selector similar to the one shown in figure 4-14. It indicates the kind of saw band you should use, the speed at which you should operate the machine, and the power feed pressure you should use to cut various materials.

**TOOTH PITCH.**—Tooth pitch is the primary consideration in selecting a saw band for any cutting job. To cut thin materials, the pitch should be fine enough so that at least two teeth are in contact with the work; fewer than two may cause the teeth to snag and tear loose from the band. To cut thick material, you should not have too many teeth in contact with the work, because as you increase the number of teeth

in contact, you must increase the feed pressure in order to force the teeth into the material.

Excessive feed pressure puts severe strain on the band and the band guides. It also causes the band to wander sideways which results in off-line cutting.

Other points to consider in selecting a saw band of proper pitch are the composition of the material to be cut, its hardness, and its toughness.

**BAND WIDTH AND GAUGE.**—The general rule is to use the widest and thickest saw band that can do the job successfully. For example, you should use a band of maximum width and thickness (if bands of different thickness are available) when the job calls for only straight cuts. On the other hand, when a layout requires radius cuts (curved cuts), select a band that can follow the sharpest curve involved. For curved work, select the widest band that will negotiate the smallest radius required. The saw band width selection guides, shown in figure 4-15, give the radius of the sharpest curve that can be cut with a particular width saw band. Note that the job selector illustrated

Deleted—No permission granted for electronic copy.

Figure 4-14.—Job selector.

Deleted—No permission granted for electronic copy.

Figure 4-15.—Saw band width selection guides.

in figure 4-14 contains a saw band radii cutting diagram similar to the one shown in figure 4-15.

**BAND SPEEDS.**—The rate at which the saw band travels in feet per minute from wheel to wheel is the saw band velocity. Saw band velocity has considerable effect upon both the smoothness of the cut surfaces and the life of the band. The higher the band velocity, the smoother the cut; however, heat generated at the cutting point increases as band

velocity increases. We cannot cover the details of adjustment because different machines use different methods. Consult the manufacturer's technical manual for your particular machine and learn how to set up the various speeds available.

**FEEDS.**—Though manual feeding of the work to the saw is satisfactory to cut metals up to 1 inch thick, power feeding generally provides better results and will be much safer for the operator. Regardless of whether you use power or manual feed, it is important not to crowd the saw because the band will tend to bend and twist. However, feed pressure must not be so light that the teeth slip across the material instead of cutting through because this rapidly dulls the teeth. The job selector, shown in figure 4-14, shows the correct feed pressures to cut any of the materials listed on the outer ring of the dial. In the absence of a job selector, you can use table 4-1 as a guide to select feed pressures for hard, medium hard, and soft metals.

The power feed controls vary with different makes of bandsaws and even with different models of the same make; therefore, we will not describe them here. Consult the manufacturer's technical manual and study the particular machine to learn its power feed arrangement and control.

**Sizing, Splicing, And Installing Bands**

Most contour cutting type bandsaws are provided with a butt welder-grinder combination, you should use it to join saw bands that come in bulk stock coil form, and to join broken band loops. The butt welder is usually attached to the saw machine, as shown in

Table 4-1.—Feed Pressures for Hard, Medium Hard, and Soft Metal

Material	Work thickness				
	0-1/4"	1/4-1/2"	1/2-1"	1-3"	Over 3"
Tool Steel . . . . .	M	M	H	H	H
Cast iron . . . . .	M	M	M	H	H
Mild steel . . . . .	L	M	H	H	H
Nickel-copper . . . . .	L	M	H	H	H
Copper-nickel . . . . .	L	L	M	H	H
Zinc . . . . .	L	L	M	M	M
Lead . . . . .	L	L	M	M	M

\* L—light, M—medium, H—heavy.

Deleted—No permission  
granted for electronic copy.

Figure 4-16.—Butt welder-grinder unit.

figure 4-16, but it may be portable or a pedestal-mounted accessory. The butt welder also makes inside cutting possible, since the saw band loop can be parted and rejoined after having been threaded through a starting hole in the work.

The following sections describe how to determine the length of the band, how to join the ends in the butt welder, and how to install a band tool in the machine.

**BAND LENGTH.**—To determine the correct saw band length for any two-wheeled bandsaw, measure the distance from the center of one wheel to the center of the other wheel, multiply by 2, and add the circumference of one wheel.

The easiest way to determine the length of saw band for a three-wheeled machine is to take a steel tape, thread it through the machine over the wheels, and measure the distance.

Before measuring between the wheel centers, adjust the upper wheel so that it is approximately halfway between the upper and lower limits of its vertical travel. This allows you to take up any band stretch.

**BAND SPLICING.**—Figure 4-16 shows band ends being joined by using a butt welder. Use the following procedure:

1. Grind both ends of the band until they are square with the band back edge. If you do not do this carefully, the weld may not go completely across the ends of the band and, as a result, the weld will not withstand the pressure of the cutting. One easy method to ensure that the ends of the band will go together perfectly is to twist one end 180 degrees and then place the band ends on top of each other. This will provide a set of teeth and a band back edge on both sides of the stacked ends. Ensure that the band back edge and the teeth are in a straight line on both sides. Carefully touch the tips of the ends of the band to the face of the grinding wheel and lightly grind until both ends have been ground completely across. Release the ends of the band so that they assume their normal position. Lay the back edge of the band on a flat surface and bring the ends together. If you did the grinding correctly, the ends will meet perfectly.

2. Set the controls of the butt welder to the weld position and adjust the adjusting lever according to the width of band to be welded. The various models of butt welders differ in the number of controls that must be set and the method of setting them. Most models have a lever that must be placed in the weld position so that the stationary and the movable clamping jaws are separated the correct distance. Some models have a resistance setting control that is set according to the width of the band, while other models have a jaw pressure control knob that is also set according to band width. Read the manufacturer's instruction manual before welding.

3. Place the ends of the band in the jaws with the teeth of the band facing away from the welder. Push the back edge of the band firmly back toward the flat surfaces behind the clamping jaws to ensure proper alignment. Position the ends of the band so that they touch each other and are located in the center of the jaw opening. Some models of butt welders have interchangeable inserts for the clamping jaws to permit welding bands of different widths. This is done so that the teeth of the band are not damaged when the jaws are clamped tight.

4. You are now ready to weld the band. Some welders require that the weld button be fully depressed and held until the welding is complete, while other welders required only that the button be fully depressed and then quickly released. There will be a shower of sparks from the welding action. Be

sure you are wearing either safety glasses or a face shield before welding and then stand back from the welder when you push the button.

5. When the welding is complete, release the jaw clamps and remove the band from the welder. Inspect the band to be sure it is straight and welded completely across. Do not bend or flex the band at this time to test the weld. The welding process has made the weld and the area near it hard and brittle and breakage will probably occur.

6. Place the lever that controls movement of the jaws in the anneal position. This should separate the jaws again. Set the control that regulates the anneal temperature to the setting for the width of the band.

7. Place the band in the clamping jaws with the teeth toward the welder and the welded section in the center of the jaw opening. Close the jaws.

8. The band is ready to be annealed. Push and then quickly release the anneal button repeatedly until the welded area becomes a dull cherry red. (Do NOT push and hold the anneal button. This will overheat and damage the band.) After the proper temperature is reached, push the anneal button and release it with increasingly longer intervals between the push cycle to allow the band to cool slowly.

9. The metal buildup resulting from the weld must be ground off. Using the attached grinding wheel, remove the weld buildup from both sides and the back of the band until the band fits snugly into the correct slot on the saw band thickness gauge mounted on the welder. Do this grinding carefully to prevent looseness or binding between the saw guides and the band. Be careful not to grind on the teeth of the band.

10. Repeat the procedure for annealing in step 8 after grinding the blade.

11. The weld is complete. To test your weld, hold the band with both hands and form a radius in the band slightly smaller than the smallest wheel on the bandsaw by bringing your hands together. Move your hands up and down in opposite directions and observe the welded area as it rolls around the radius that you formed.

**BAND INSTALLATION.**—Insert saw band or tool guides of the correct size for the band you are going to install. Adjust the upper band wheel for a height that will allow you to easily loop the band around the wheels. Then place one end of the loop over the upper band wheel and the other end of the loop around the lower band wheel. Be sure that the

Deleted—No permission  
granted for electronic copy.

**Figure 4-17.—Upper wheel tilt adjustment.**

teeth are pointing downward on the cutting side of the band loop and that the band is properly located in the guides. Place a slight tension on the band by turning the upper wheel takeup hand wheel. Revolve the upper band wheel by hand until the band has found its tracking position. If the band does not track on the center of the crowns of the wheels, use the upper wheel tilt control to correct the band track as illustrated in figure 4-17.

When the band is tracking properly, adjust the band guide rollers or inserts so that you have a total clearance of 0.001 to 0.002 inch between the sides of the band back and the guide rollers or inserts, and a slight contact between the back edge of the band back and the backup bearings of the guides. When you have set the band guide clearance, increase the band tension. The amount of tension to put on the band depends on the width and gauge of the band. A narrow, thin band will not stand as much tension as a wider or thicker band. Too much tension will cause the saw to break; insufficient tension will cause the saw to run off the cutting line. The best way to obtain the proper tension is to start with a moderate tension; if the saw tends to run off the cutting line, increase the tension slightly.

## **Sawing Operations**

We mentioned earlier in the chapter that you can use a band tool machine to do straight, angular, contour, inside, and disk cutting. The following

Deleted—No permission  
granted for electronic copy.

**Figure 4-18.—Work jaw and feed chain adjustment.**

paragraphs contain the procedures for each of these cutting operations. But first, let us consider the general rules applicable to all sawing operations.

- Check the level of the work table and adjust the table, if necessary, to suit the angle of the cut.
- Use the proper blade and speed for each cutting operation. This ensures not only the fastest and most accurate work but also longer saw life.
- Always be sure the band guide inserts are the correct size for the width of the band and that they are properly adjusted.
- Before starting the machine, adjust the height of the upper band guide so that it will clear the work from 1/8 to 3/8 inch. The closer the guide is to the work, the greater the accuracy.
- When starting a cut, feed the work to the saw gradually. After the saw has started the kerf, increase the feed slowly to the recommended pressure. Do not make a sudden change in feed

pressure because it may cause the band to break.

- Be sure the saw band and guides are properly lubricated.
- Use lubricants and cutting coolants as recommended by the manufacturer of your machine.

**STRAIGHT CUTTING WITH POWER FEED.**—Most band saws are equipped with hydraulically actuated power feeds. When used, accidental overfeeding is eliminated which greatly extends blade life. To use the power feed:

1. Change band guides as necessary. Select and install the proper band for the job and adjust the band guides.
2. Place the workpiece on the table of the machine and center the work in the work jaw.
3. Loop the feed chain around the work jaw, the chain roller guides, and the left-right guide sprocket, as shown in figure 4-18.

Deleted—No permission granted for electronic copy.

Deleted—No permission granted for electronic copy.

**Figure 4-19.—Angular cutting.**

4. Determine the proper band speed and set the machine speed accordingly.
5. Start the machine and feed the work to the saw in the manner described in the general rules of operation given in the preceding section. Use the left-right control for guiding the work along the layout line.

**ANGULAR CUTTING.**—Make angular or bevel cuts on flat pieces the same way as straight cuts except you should tilt the table to the desired angle of the cut as shown in figure 4-19.

**CONTOUR CUTTING.**—You can do contour cutting, that is, following straight, angle, and curved layout lines, offhand or with the power feed. Use the left-right chain control, shown in figure 4-18, to guide the work along the layout line when you use power feed. A fingertip control to actuate the sprocket is located at the edge of the work table. If there are square corners in the layout, drill a hole adjacent to each corner; this will permit the use of a wider band, greater feed pressure, and faster cutting. Figure 4-20 shows the placement of corner holes on a contour cutting layout.

**INSIDE CUTTING.**—To make an inside cut, drill a starting hole slightly larger in diameter than the width of the band you are going to use. Remove the band from the machine. Shear the band, slip one end through the hole, and then splice the band. When you

**Figure 4-20.—Sharp radii cutting eliminated by drilling corner holes.**

have done that, reinstall the band and the machine is ready to make the inside cut as illustrated in figure 4-21.

**DISK CUTTING.**—You can do disk cutting offhand if you lay out the circle on the workpiece and follow the layout circle, or you can use a disk cutting attachment that automatically guides the work so that

Deleted—No permission granted for electronic copy.

**Figure 4-21.—Inside cutting.**

Deleted—No permission  
granted for electronic copy.

Deleted—No permission  
granted for electronic copy.

**Figure 4-22.—Disk-cutting attachment.**

you cut a perfect circle. Figure 4-22 shows a disk cutting attachment in use. The device consists of a radius arm, a movable pivot point, and a suitable clamp to attach the assembly to the saw guidepost. To cut a disk using this device, lay out the circle and punch a center point. Clamp the radius arm to the guidepost. Position the workpiece (fig. 4-22) so that the saw teeth are tangent to the scribed circle. Adjust the pivot point radially and vertically so that it seats in the center-punch mark; then clamp the pivot point securely. Then rotate the work around the pivot point to cut the disk.

**FILING AND POLISHING.**—In filing and polish finishing, you will manually feed and guide the work to the band. Proper installation of the guides and backup support strips is very important if you expect good results. A guide fence similar to the one shown in figure 4-23 is very helpful when you work to close tolerances. Be sure to wear goggles or an eye protection shield to file and polish, and above all, be careful of your fingers. For proper band speeds and work pressures, consult the manufacturer's technical manual for the machine you are using.

## **DRILLING MACHINES AND DRILLS**

Although drilling machines or drill presses are commonly used by untrained personnel, you cannot assume that you will operate these machines proficiently if you simply insert the proper size drill and start the machine. As a Machinery Repairman, you will be required to perform drilling operations with a great degree of accuracy. Therefore you must

**Figure 4-23.—Polish finishing.**

be well acquainted with the types of machines and the methods and techniques of operation of drill presses and drills found in Navy machine shops.

A diverse group of people with different training and experience backgrounds use the drill press. Because of that some unsafe operating practices have become routine in spite of the possibility of serious injury. The basic safety precautions for the use of a drill press are listed below:

- Always wear goggles or safety glasses, and wear ear protection when warning signs are posted.
- Keep loose clothing clear of rotating parts.
- **NEVER** attempt to hold a piece being drilled in your hand. Use a vise, hold-down bolts or other suitable clamping device.
- Check the twist drill to be sure that it is properly ground and is not damaged or bent.
- Make sure the cutting tool is held tightly in the drill press spindle.
- Use the correct feeds and speeds.
- When feeding by hand, take care that the drill does not dig in and take an uncontrolled depth of cut.
- Do not remove chips by hand. Use a brush.

The two types of drilling machines or drill presses common to the Navy machine shop are the upright



drill press and the radial drill press. These machines have similar operating characteristics but differ in that you position the drilling lead on the radial drill, and you position the workpiece on the upright drill.

### UPRIGHT DRILL PRESSES

Upright drill presses discussed in this section will be the general purpose, the heavy duty, and the sensitive drill presses. Nearly all ships have one or more of these types. They are classified primarily by the size of drill that can be used, and by the size of the work that can be set up.

#### General Purpose Drill Press (Round Column)

Shown in figure 4-24, the general purpose drill press is the most common type of machine found in Navy machine shops. The basic components of this machine are shown in the illustration.

The base has a machined surface with T-slots for heavy or bulky work.

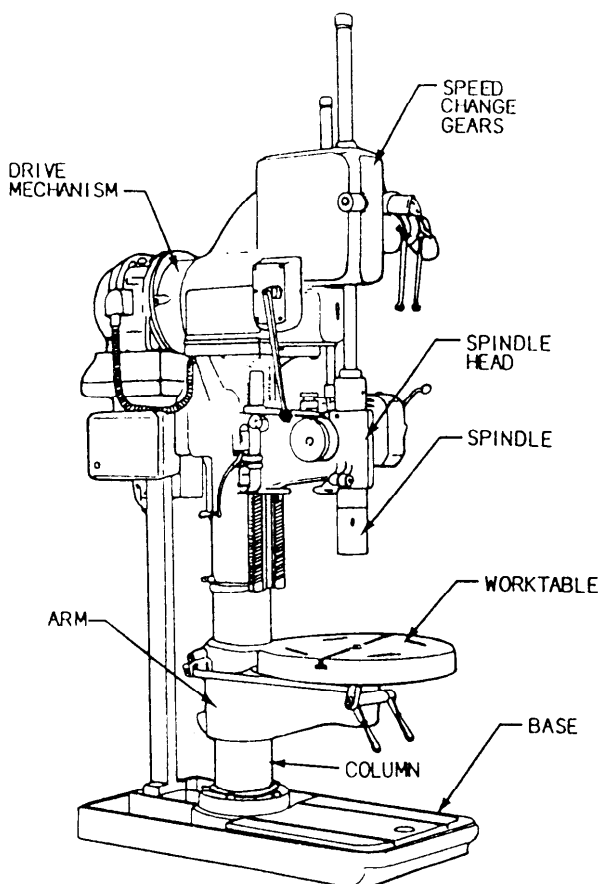


Figure 4-24.—General purpose drill press.

The column supports the work table, the drive mechanism and the spindle head.

The work table and arm can be swiveled around the column and can be moved up or down to adjust for height. In addition, the work table may be rotated 360° about its own center.

The spindle head guides and supports the spindle and can be adjusted vertically to provide maximum support near the spindle socket.

The spindle is a splined shaft with a Morse taper socket to hold the drill. The spline permits vertical movement of the spindle while it is rotating.

The drive mechanism includes the motor, speed and feed change gears, and mechanical controls.

#### Heavy Duty Drill Press (Box Columns)

The heavy duty drill press (fig. 4-25) is normally used to drill large holes. It differs from the general purpose drill press in that the work table moves only

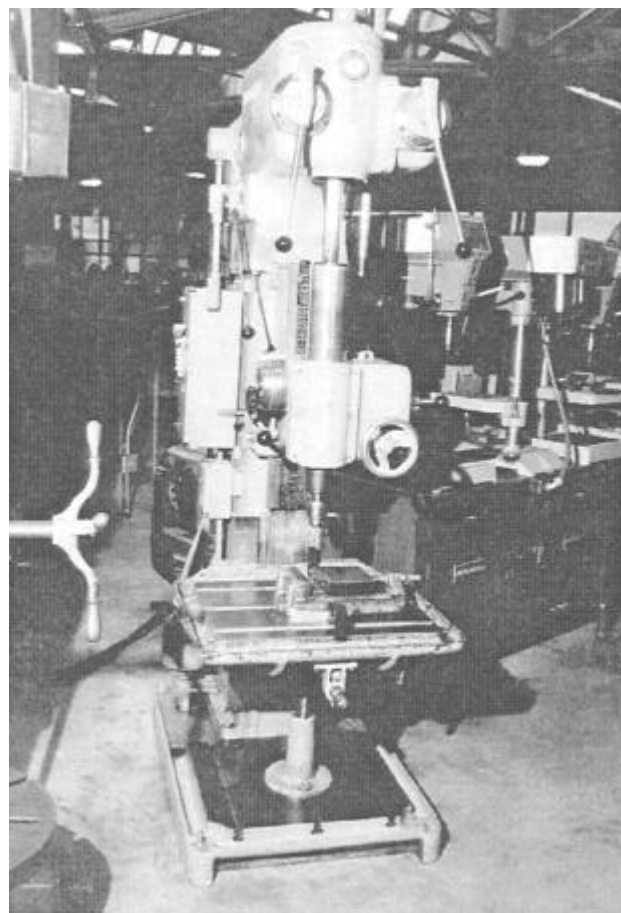


Figure 4-25.—Heavy duty drill press.

28.477

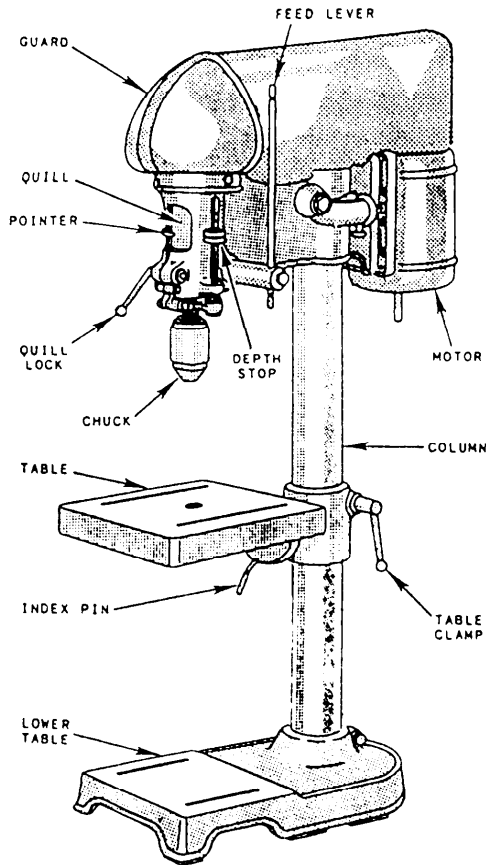


Figure 4-26.—Sensitive drill press.

vertically. The work table is firmly gibbed to vertical ways or tracks on the front of the column and is further supported by a heavy adjusting screw from the base to the bottom of the table. As the table can be moved only vertically, it is necessary to position the work for each hole.

### Sensitive Drill Press

The sensitive drill press (fig. 4-26) is used to drill small holes in work under conditions that make it necessary for the operator to “feel” what the cutting tool is doing. The tool is fed into the work by a very simple device—a lever, a pinion and shaft, and a rack that engages the pinion. These drills are nearly always belt-driven because the vibration caused by gearing would be undesirable. Sensitive drill presses are used to drill holes less than one-half inch in diameter. The high-speed range of these machines and the holding devices used make them unsuitable for heavy work.

### RADIAL DRILL PRESS

The radial drill press shown in figure 4-27, has a spindle head on an arm that can be rotated axially on

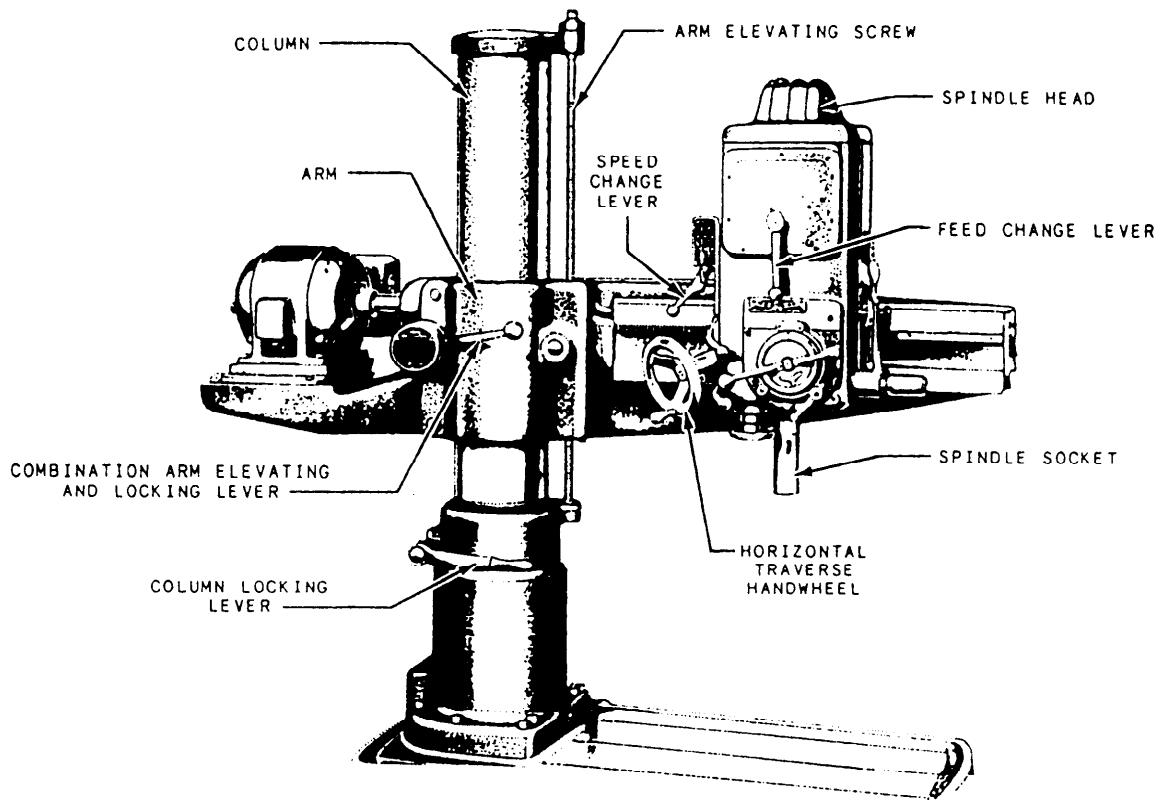


Figure 4-27.—Radial drill press.

the column. The spindle head may be traversed horizontally along the ways of the arm, and the arm may be moved vertically on the column. This machine is especially useful when the workpiece is bulky or heavy or when you need to drill many holes with one setup. The arm and spindle are designed so that the drill can be positioned easily over the layout of the workpiece.

Some operational features that are common to most radial drill presses are: (1) high- and low-speed ranges provided from either a two-speed drive motor or a low-speed drive gear; (2) a reversing mechanism to change the direction of rotation of the spindle by either a reversible motor or a reversing gear in the drive gear train; (3) automatic feed mechanisms that are driven from the spindle and feed the cutting tool at a selected rate per revolution of the spindle; (4) depth setting devices that permit the operator to preset the required depth of penetration of the cutting tool; and (5) coolant systems to provide lubrication and coolant to the cutting tool.

On other machines you can place the control levers in different positions; however, they serve the same purposes as those shown. Use the locking clamps to lock or “dog down” the table or head of a drill after it is positioned over the work. But make sure the locking action does not cause the drill or work to move slightly out of position.

## TWIST DRILL

The twist drill is the tool generally used to drill holes in metal. This drill is formed either by forging and twisting grooves in a flat strip of steel or by milling a cylindrical piece of steel.

In figure 4-28 you see the principal parts of a twist drill: the body, the shank, and the point. The portion of the land behind the margin is relieved to provide body clearance. The body clearance helps reduce friction during drilling. The lip is the cutting edge, and the area called the lip clearance is on the cone of the drill. The dead center is the sharp edge located at the tip end of the drill. It is formed by the intersection of the cone-shaped surfaces of the point and should always be in the exact center of the axis of the drill. Do not confuse the point of the drill with the dead center. The point is the entire cone-shaped surface at the cutting end of the drill. The web of the

drill is the metal column that separates the flutes. It runs the entire length of the body between the flutes and gradually increases in thickness toward the shank, giving additional rigidity to the drill.

The tang is found only on tapered-shank tools. It fits into a slot in the socket or spindle of the drill press and bears a portion of the driving strain. Its principal purpose is to make it easy to remove the drill from the socket with the aid of a drill drift. (NEVER use a file or screwdriver to do this job.)

The shank is the part of the drill that fits into the socket, spindle, or chuck of the drill press. The types of shanks that are most often found in Navy machine

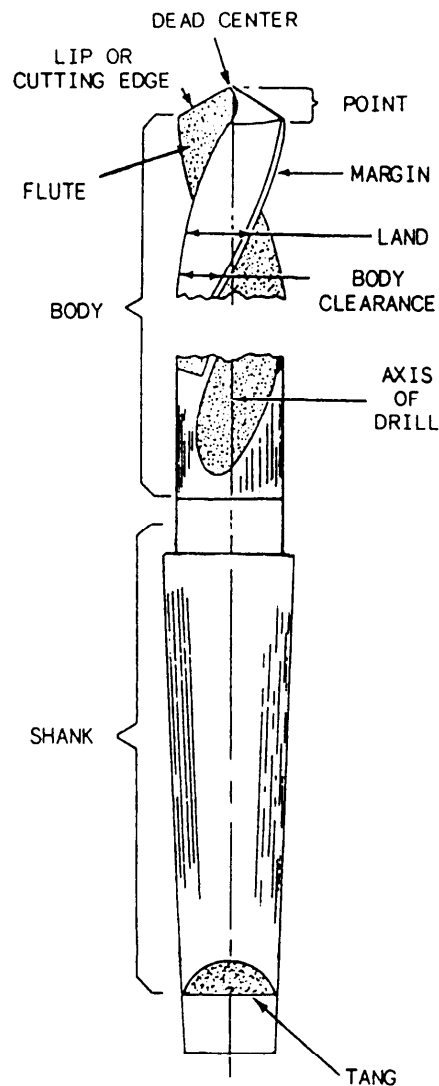


Figure 4-28.—The parts of a twist drill.

shops are the Morse taper shank, shown in figures 4-28 and 4-29A and the straight shank, shown in figures 4-29B and 4-29C.

Twist drills are made from several different materials. Drills made from high-carbon steel are available; however, their use is limited by the low cutting speed required to keep this type of drill from becoming permanently dull. Most of the twist drills that you will use are made from high-speed steel and will have two flutes (fig. 4-28).

Core drills (fig. 4-29A) have three or more flutes and are used to enlarge a cast or previously drilled hole. Core drills are more efficient and more accurate than the standard two-fluted drill. Core drills are made from high-speed steel.

A carbide-tipped drill (fig. 4-29B), is similar to a standard two-fluted drill with carbide inserts mounted along the lip or cutting edge. It is used to drill nonferrous metals, cast iron, and cast steel at high speeds. These drills are not designed for drilling steel and alloy metals.

A carbide-tipped die drill is also known as a spade drill (fig. 4-29C). It has two flutes that run parallel to the axis of the drill as opposed to the helical flutes of the standard two-fluted drill. It can be used to drill holes in hardened steel.

A standard two-fluted drill made from cobalt high-speed steel is superior in cutting efficiency and wear resistance to the high-speed steel drill. It is used at a cutting speed between the speed recommended for a high-speed steel drill and a carbide-tipped drill.

A solid carbide drill with two helical flutes is also available and can be used to drill holes in hard and abrasive metal where no sudden impact will be applied to the drill.

Drill sizes are indicated in three ways: by measurement, letter, and number. The nominal measurements range from 1/16 to 4 inches or larger, in 1/64-inch steps. The letter sizes run from "A" to "Z" (0.234 to 0.413 inch). The number sizes run from No. 80 to No. 1 (0.0135 to 0.228 inch).

Before putting a drill away, wipe it clean and then give it a light coating of oil. Do not leave drills in a place where they may be dropped or where heavy objects may fall on them. Do not place drills where they will rub against each other.

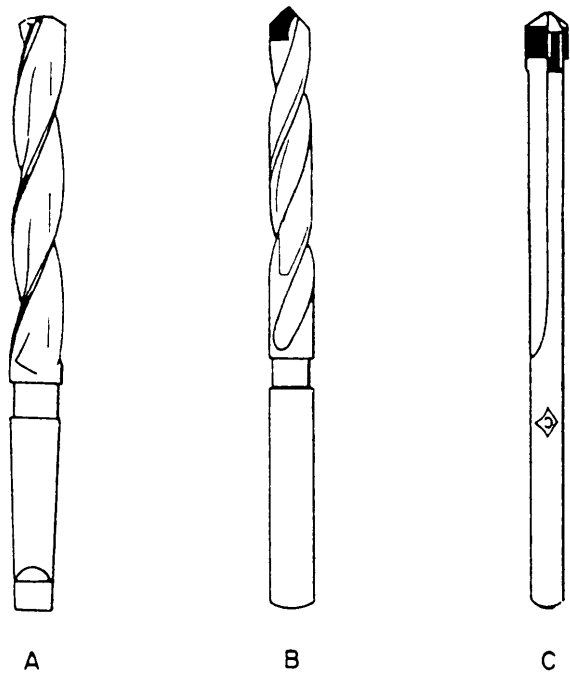


Figure 4-29.—Twist drills: A. Three-fluted core drill; B. Carbide tipped drill with two helical flutes; C. Carbide tipped die drill with two flutes parallel to the drill axis.

## DRILLING OPERATIONS

Using the drill press is one of the first skills you will learn as a Machinery Repairman. Although a drill press is simpler to operate and understand than other machine tools in the shop, the requirements for accuracy and efficiency are no less strict. To achieve skill, you must know how to set feeds and speeds, how to hold the work, and how to ensure accuracy.

### Speeds, Feeds, and Coolants

The cutting speed of a drill is expressed in feet per minute (fpm). This speed is computed by multiplying the circumference of the drill (in inches) by the revolutions per minute (rpm) of the drill. The result is then divided by 12. For example, a 1/2-inch drill turned at 100 rpm has a surface speed of 150 inches per minute. To obtain fpm, divide this figure by 12 which results in a cutting speed of approximately 12 1/2 feet per minute.

The correct cutting speed for a job depends on many factors. The main ones are: The machinability of a metal, any heat treatment process such as hardening, tempering, or normalizing, the type of drill used, the type and size of the drilling machine, the rigidity of the setup, the finish and accuracy required,

and whether or not a cutting fluid is used. The following cutting speeds are recommended for high-speed steel twist drills. Carbon steel drills should be run at one-half these speeds, while carbide may be run at two to three times these speeds. As you gain experience, you will be able to vary the speeds to suit the job you are doing.

Low carbon steel . . . . .	80-110 fpm
Medium carbon steel . . . . .	70-80 fpm
Alloy steel . . . . .	50-70 fpm
Corrosion-resistant steel (stainless) . . . . .	30-40 fpm
Brass. . . . .	200-300 fpm
Bronze . . . . .	200-300 fpm
Monel . . . . .	40-50 fpm
Aluminum . . . . .	200-300 fpm
Cast iron . . . . .	70-150 fpm

The speed of the drill press is given in rpm. Your shop will usually have tables giving the proper rpm at which to run a drill press for a particular metal or you may find them in machinists' handbooks. You can use a formula to determine the rpm required to give a specific rate of speed in fpm for a specific size drill. For example, if you wish to drill a hole 1 inch in diameter at the speed of 50 fpm, you would compute the rpm as follows:

$$\begin{aligned}
 rpm &= \frac{fpm \times 12}{\pi \times D} \\
 &= \frac{50 \times 12}{3.1415 \times 1} \\
 &= \frac{600}{3.1416} \\
 &= 190
 \end{aligned}$$

where

$fpm$  = required speed in feet per minute

$\pi$  = 3.1416

12 = constant

$D$  = diameter of drill in inches

The feed of a drill is the rate of penetration into the work for each revolution. Feed is expressed in thousandths of an inch per revolution. In general, the larger the drill, the heavier the feed you may use. Always decrease feed pressure as the drill breaks through the bottom of the work to prevent drill breakage and rough edges. The rate of feed depends on the size of the drill, the material you are drilling, and the rigidity of the setup.

Use the following feed rates, given in thousandths of an inch per revolution (ipr), as a general guide until your experience allows you to determine the most efficient feed rate for each different job.

<u>Drill Diameter</u>	<u>IPR</u>
No. 80 to 1/8 inch	0.001-0.002
1/8 inch to 1/4 inch	0.002-0.004
1/4 inch to 1/2 inch	0.004-0.007
1/2 inch to 1 inch	0.007-0.015
Greater than 1 inch	0.015-0.025

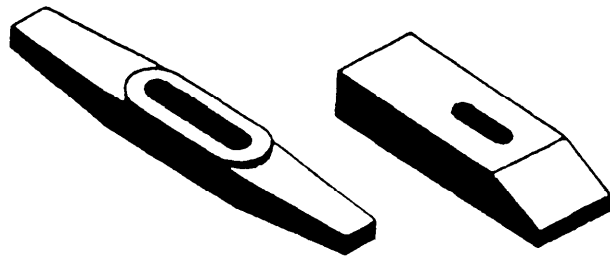
Use the lower feed rate given for each range of drill sizes for the harder materials such as tool steel, corrosion-resistant steel and alloy steel. Use the higher feed rate for brass, bronze, aluminum, and other soft metals.

It is usually necessary to use a cutting oil or coolant to drill carbon steel, alloy steel, corrosion-resistant steel and certain nonferrous metals such as Monel. For most drilling operations, you can use soluble oil or a synthetic coolant. You may drill aluminum, brass, cast iron, bronze and similarly soft metals dry unless you use a high drilling speed and feed.

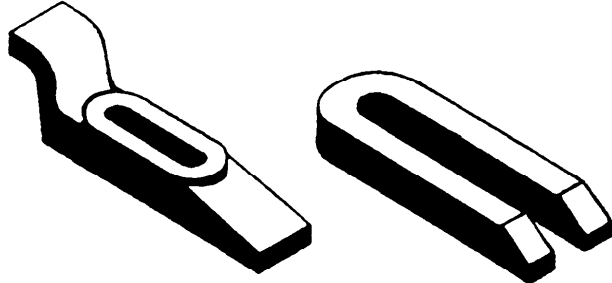
### **Holding the Work**

Before drilling, be sure your work is well clamped down. On a sensitive drill press you will probably have to use a drill vise and center the work by hand. Because the work done on this drill press is comparatively light, the weight of the vise is sufficient to hold the work in place.

The larger drill presses have slotted tables upon which you may bolt or clamp work of considerable weight. Use T-bolts, which fit into the T-slots on the table, to secure the work. You can also use various



FLAT STRAPS



GOOSENECK STRAP

U-STRAP

Figure 4-30.—Common types of clamping straps.

types of clamping straps, shown in figure 4-30. (Clamping straps are also identified as clamps or dogs.) The U-strap is the most convenient for many setups because it has a larger range of adjustment.

It is often necessary to use tools such as steel parallels, V-blocks, and angle plates to support and hold the work. Use steel parallels to elevate the work above the table so you can better see the progress of the drill. Use V-blocks to support round stock, and angle plates to support work where you will drill a hole at an angle to another surface. Figure 4-31 shows some examples of setups.

### Drilling Hints

To ensure accuracy in drilling, position the work accurately under the drill. Use the proper techniques to prevent the drill from starting off center or from moving out of alignment during the cut. Here are some hints that will help you to correctly start and complete a drilling job.

- Before setting up the machine, wipe all foreign matter from the spindle and the table. A chip in the spindle socket will cause the drill to have a wobbling effect which tends to make the hole larger than the drill. Foreign matter on the work holding device under the workpiece tilts it in relation to the spindle, causing the hole to be out of alignment.

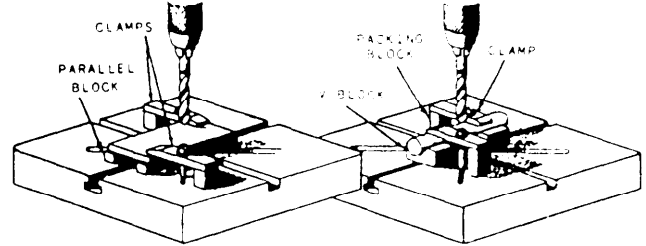
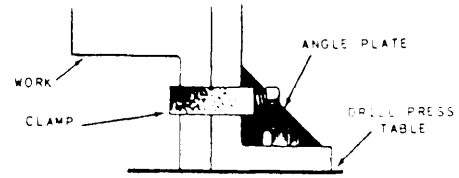


Figure 4-31.—Work mounted on the table.

- Center punch the work at the point to be drilled. Position the center-punched workpiece under the drill. Use a dead center inserted in the spindle socket to align the center-punch mark on the workpiece directly under the axis of the spindle.
- Bring the spindle with the inserted center down to the center-punch mark and hold it in place lightly while you fasten the locking clamps or dogs. This will prevent slight movement of the workpiece, table, or both when they are clamped in position.
- Insert a center drill (fig. 4-32) in the spindle and make a center hole to aid in starting the drill. This is not necessary on small drills on which the dead center of the drill is smaller than the center-punch mark. But on large drills it will prevent the drill from “walking” away from the center-punch mark. This operation is especially important to drill holes on curved surfaces.

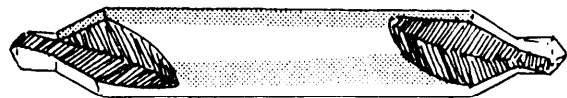


Figure 4-32.—Combined drill and countersink (center drill).

- If you use a drill smaller than the required size to make a pilot hole, it will increase accuracy by eliminating the need to do any cutting with the dead center of the finishing drill. This will decrease the pressure required to feed the finishing drill, and decrease the width of cut taken by each drill. In drilling holes over 1 inch in diameter, you may need to use more than one size of pilot drill to increase the size of the hole by steps until you reach the finished size.
- If the outer corners of the drill (margin) appear to be wearing too fast or have a burnt look, the drill is going too fast.
- If the cutting edges (lips) chip during drilling, you have ground too much lip clearance into the drill, or you are using too heavy a feed rate.
- A very small drill will break easily if the drill is not going fast enough.
- When you drill a hole that is more than three or four times the drill diameter in depth, back out the drill frequently to clear the chips from the flutes.
- If the drill becomes hot quickly, is difficult to feed, squeals when being fed and produces a rough finish in the hole, it has become dull and requires sharpening.
- If the drill has cutting edges of different angles or unequal length, the drill will cut with only one lip and will wobble in operation. This will produce an oversized hole.
- If the drill will not penetrate the work, you have ground insufficient or no lip clearance into the drill.
- The majority of drilled holes will be oversized regardless of the care you take to ensure a good setup. Generally, you can expect the oversize to average an amount equal to 0.004 inch times the drill diameter plus 0.003 inch. For example, you can expect a 1/2-inch drill to produce a hole approximately 0.505 in diameter ( $[0.004 \times 0.500] + 0.003$ ). This amount can vary up or down depending on the condition of the drilling machine and the twist drill.

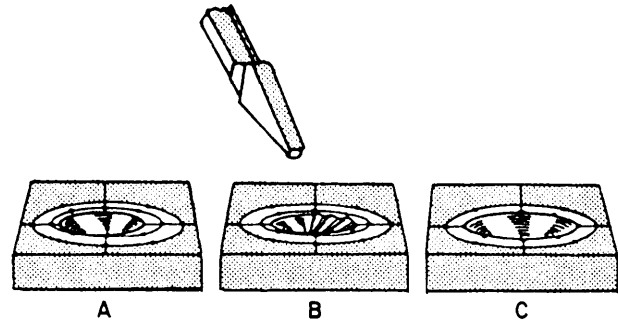


Figure 4-33.—Using a half-round chisel to guide a drill to the correct center.

### Correcting Offcenter Starts

A drill may start off center because of improper center drilling, careless starting of the drill, improper grinding of the drill point, or hard spots in the metal. To correct this condition, (See fig. 4-33.) take a half-round chisel and cut a groove on the side of the hole toward which the center is to be drawn. The depth of this groove depends upon the eccentricity (deviation from center) of the partially drilled hole with the hole to be drilled. When you have drilled out the groove, lift the drill from the work and check the hole for concentricity with the layout line. Repeat the operation until the edge of the hole and the layout line are concentric.

When you use this method to correct an off center condition, be very careful that the cutting edge or lip of the drill does not grab in the chisel groove. Generally, you should use very light feeds until you establish the new center point. (Heavy feeds cause a sudden bite in the groove which may push the work out of the holding device, or break the drill.)

### Counterboring, Countersinking, and Spotfacing

A counterbore is a drilling tool used in the drill press to enlarge portions of previously drilled holes. The purpose is to allow the heads of fastening devices to be flush with or below the surface of the workpiece. The parts of a counterbore that distinguish it from a regular drill are a pilot, which aligns the tool in the hole to be counterbored, and the cutting edge of the counterbore, which is flat so that a flat surface is left at the bottom of the cut, enabling fastening devices to seat flat against the bottom of the counterbored hole.

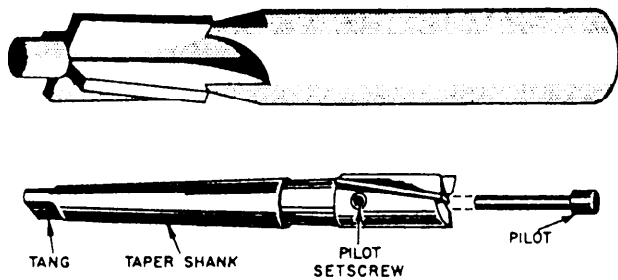


Figure 4-34.—Two types of counterbore.

Figure 4-34 shows two types of counterbores and an example of a counterbored hole. The basic difference between the counterbores illustrated is that one has a removable pilot and the other does not. You can use a counterbore with a removable pilot to counterbore a range of hole sizes by simply using the appropriate size pilot. A counterbore with a fixed pilot may be used only with holes of the same dimensions as the pilot.

Countersinks are used to seat flathead screws flush with the surface. The basic difference between countersinking and counterboring is that a countersink makes an angular sided recess, while the counterbore forms straight sides. The angular point of the countersink acts as a guide to center the tool in the hole being countersunk. Figure 4-35 shows two common types of countersinks.

Spotfacing is an operation that cleans up the surface around a hole so that a fastening device can be seated flat on the surface. This operation is commonly required on rough surfaces that have not been machined and on the circumference of concave or convex workpieces. Figure 4-36 shows an

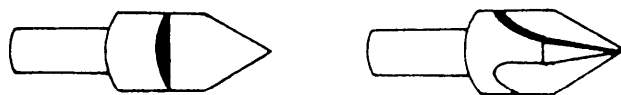


Figure 4-35.—Countersinks.

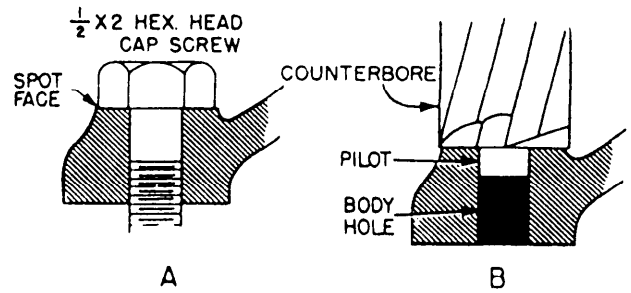


Figure 4-36.—Examples of spotfacing.

example of spotfacing and its use with fastening devices. You will usually do this with a counterbore.

## Reaming

The drill press also may be used for reaming. For example, when specifications call for close tolerances, the hole must be drilled slightly undersize and then reamed to the exact dimension. Reaming also removes burrs in a drilled hole or enlarges a previously used hole for new applications.

Machine reamers have tapered shanks that fit the drilling machine spindle. Be sure not to confuse them with hand reamers, which have straight shanks. You will ruin hand reamers if you use them in a machine.

There are many types of reamers, but the ones used most extensively are the straight-fluted, the taper pin, and the expansion types. They are illustrated in figure 4-37.

The straight-fluted reamer is made to remove small portions of metal and to cut along the edges to bring a hole to close tolerance. Each tooth has a rake angle that is comparable to that on a lathe tool.

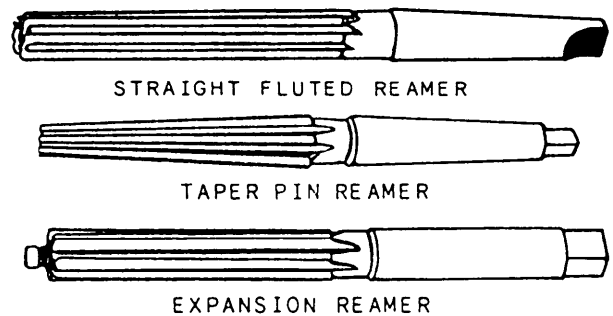


Figure 4-37.—Reamers.



The taper pin reamer has a tapered body and is used to smooth and true tapered holes and recesses. The taper pin reamer is tapered at 1/4 inch per foot.

The expansion reamer is especially useful to enlarge reamed holes by a few thousandths of an inch. It has a threaded plug in the lower end which expands the reamer to various sizes.

To ream a hole, follow the steps outlined below:

1. Drill the hole about 1/64 inch less than the reamer size.
2. Substitute the reamer in the drill press without removing the work or changing the position of the work.
3. Adjust the machine for the proper spindle speed. (Reamers should turn at about one-half the speed of the twist drill.)
4. Use a cutting oil to ream. Use just enough pressure to keep the reamer feeding into the work; excessive feed may cause the reamer to dig in and break.
5. The starting end of a reamer is slightly tapered; always run it all the way through the hole. **NEVER RUN A REAMER BACKWARD** because the edges are likely to break.

### Tapping

Special attachments allow you to cut internal screw threads with a tap driven by the drilling machine spindle. They can save considerable time when you must thread a number of identically sized holes. The attachment is equipped with a reversing device that automatically changes the direction of rotation of the tap when either the tap strikes the bottom of the hole or a slight upward pressure is applied to the spindle down-feed lever. The reversing action takes place rapidly, permitting accurate control over the depth of the threads being cut. A spiral-fluted tap should be used to tap a through hole while a standard straight-fluted plug tap can be used in a blind hole. A good cutting oil should always be used in tapping with a machine.

### DRILLING ANGULAR HOLES

An angular hole is a hole with a series of straight sides of equal length. A square (4-sided), a hexagon (6-sided), a pentagon (5-sided), and an octagon (8-sided) are examples of angular holes. You can use a broach to make an angular hole that goes all the way

through a part. However, you will need an angular drill to make a blind hole, one in which the angular hole does not go all the way through the part.

### ANGULAR DRILL EQUIPMENT

The equipment required to drill angular holes is specialized and is designed to do only this particular operation. The following paragraphs contain a brief description of the equipment. A complete description of the equipment and its use is available from the manufacturer when the equipment is ordered.

#### Chuck

The chuck (fig. 4-38A) used to drill angular holes is of an unusual design. While it holds the drill in a position parallel to the spindle of the lathe or drill press and prevents it from revolving, it allows the drill to float freely so that the flutes can follow the sides of the angular hole in the guide plate. The chuck is available with a Morse taper shank to fit most lathes and drill presses. There are several different sizes of chucks, each capable of accepting drills for a given range of hole sizes.

#### Guide Plates

The guide plate (fig. 4-38B) is the device that causes the drill to make an angular hole. The free-floating action of the chuck allows the drill to

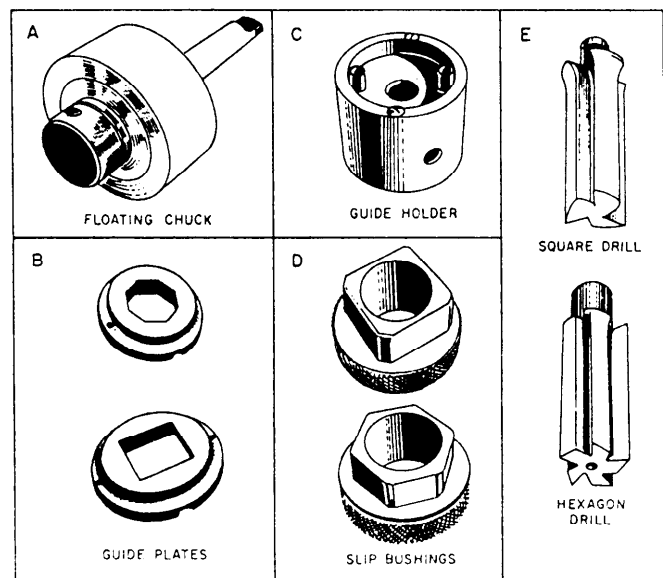


Figure 4-38.—Equipment for drilling angular holes. A. Chuck; B. Guide plate; C. Guide holder; D. Slip bushing; E. Angular drill.

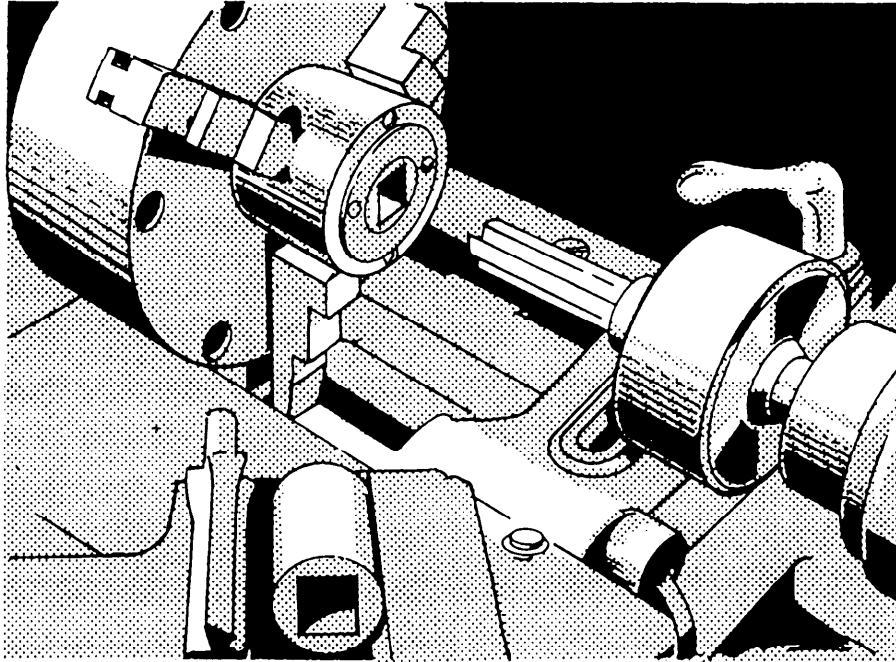


Figure 4-39.—Lathe setup for drilling an angular hole.

randomly follow the straight sides and corners of the guide plate as it is fed into the work. Attach the guide plate to a guide holder when you use a lathe and directly to the work when you use a drill press. A separate guide plate is required for each different shape and size hole.

### Guide Holder

The guide holder (fig. 4-38C), as previously stated, holds the guide plate and is placed over the outside diameter of the work and locked in place with a setscrew. Use the guide holder when you are doing the work in a lathe; it is not required for drill press operations.

### Slip Bushings

Before you drill with the angular hole drill, you must drill a normal round hole in the center of the location where the angular hole will be located. This pilot hole reduces the pressure that would otherwise be required to feed the angular drill and ensures that the angular drill will accurately follow the guide plate. In a lathe, you need only drill a hole using the tailstock since it and the chuck will automatically center the pilot hole. In a drill press, you must devise a method to help you align the pilot hole. A slip bushing will do the job quickly and accurately. The slip bushing (fig. 4-38D) fits into the guide plate. It

has a center hole which is the correct size for the pilot hole of the particular size angular hole being drilled. After you have installed the bushing, position the correct drill so that it enters the hole in the slip bushing and drill the pilot hole.

### Angular Drill

The angular drills (fig. 4-38E) are straight fluted and have one less flute or cutting lip than the number of sides in the angular hole they are designed to drill. The drills have straight shanks with flats machined on them to permit securing them in the floating chuck with setscrews. The cutting action of the drill is made by the cutting lips or edges on the front of the drill.

### OPERATION

The procedure to drill an angular hole is similar to that to drill a normal hole, differing only in the preliminary steps required in setting the job up. The feeds and speeds used to drill angular holes should be slower than those recommended to drill a round hole of the same size. Obtain specific recommendations concerning feeds and speeds from the information provided by the manufacturer. Use a coolant to keep the drill cool and help flush away the chips.

The following procedures apply when you do the work on a lathe. See figure 4-39 for an example of a lathe setup.

1. Place the work to be drilled in the lathe chuck. The work must have a cylindrical outside diameter and the intended location of the angular hole must be in the center of the work.
2. Place the guide holder over the outside diameter of the work and tighten the setscrew. If the bore in the back of the guide holder is larger than the diameter of the work, make a sleeve to adapt the two together. If the part to be drilled is short, place it in the guide holder and place the guide holder in the chuck.
3. Drill the pilot hole at this time. The size of the pilot hole should be slightly smaller than the distance across the flats of the angular hole. The manufacturer makes specific recommendations on pilot hole sizes.
4. Attach the guide plate to the guide holder.
5. Mount the floating chuck in the lathe tailstock spindle and place the drill in the chuck. Tighten the setscrews to hold the drill securely.
6. You are now ready to drill the angular hole. Do not force the drill into the work too rapidly, and use plenty of coolant.

The following procedures apply when you drill an angular hole on a drill press. Clamp the guide plate directly to the work and drill the pilot hole by using a slip bushing placed in the guide plate to ensure alignment. Once you have positioned the work under the drill press spindle and have drilled the pilot hole, do not move the setup. Any movement will cause misalignment between the work and the angular drill.



## CHAPTER 5

# OFFHAND GRINDING OF TOOLS AND SELECTION OF CARBIDE TOOLING

### CHAPTER LEARNING OBJECTIVES

*Upon completing this chapter, you should be familiar with the following:*

- *Identify and explain the use of grinding equipment.*
- *Identify and explain the use of grinding wheels.*
- *Identify and explain the use of single-point cutting tools.*
- *Identify and explain the use of carbide tools*

One requirement for advancement in the MR rating is the ability to grind and sharpen some of the tools used in the machine shop. The equipment used for this purpose includes bench, pedestal, carbide, and chip breaker grinders and precision grinding machines. This chapter explains the use of these grinders and how to grind small tools by using the offhand grinding technique. (We'll cover precision grinding machines in a later chapter.)

In grinding, you use the cutting action of an abrasive to remove metal. In offhand grinding you hold the workpiece in your hand and position it against the grinding surface. You must have experience and practice to do this accurately and safely. You also must know how to install grinding wheels on pedestal and bench grinders and how to sharpen or dress them.

Before you can properly grind small handtools, single-edged cutting tools, and twist drills, you must know the terms used to describe their angles and surfaces. You also must know the composition of the material from which each tool is made and the operations for which the tool is used.

Advancing technology has made carbides the dominate cutting tool in machine shops. You must understand carbide terminology and the use of carbide tools.

### GRINDING SAFETY

The grinding wheel is a fragile cutting tool that operates at high speeds. Therefore, the safe operation of bench and pedestal grinders is as important as proper grinding techniques. Follow all posted safety precautions. Review your equipment operators manual for other safety precautions and any chapters of *Navy Occupational Safety and Health (NAVOSH) Program Manual for Forces Afloat*, OPNAV Instruction 5100.19B, that apply to the equipment.

### BENCH AND PEDESTAL GRINDERS

Bench grinders (fig. 5-1) are small, self-contained, and usually mounted on a workbench. Use them to grind and sharpen small tools such as lathe, planer,

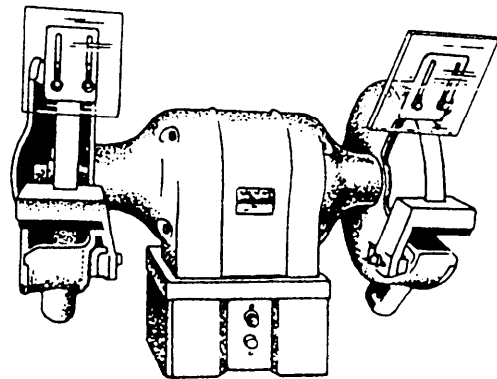


Figure 5-1.—Bench grinder.

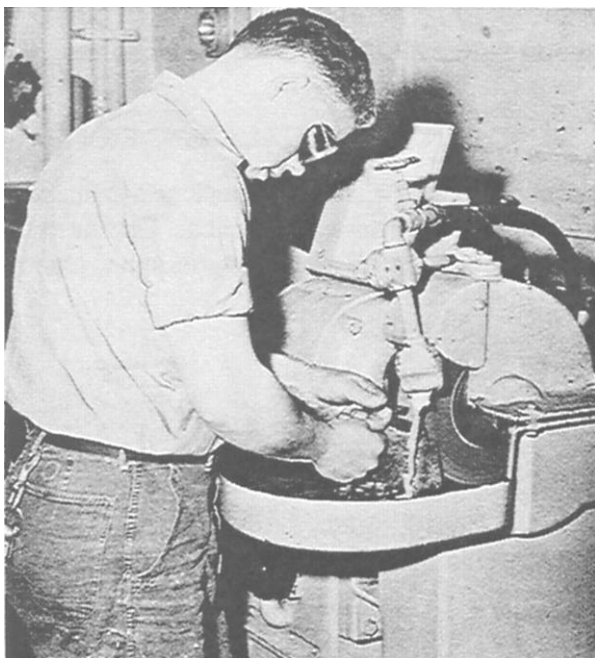
and shaper cutting tools; twist drills; and handtools such as chisels and center punches. These grinders do not have installed coolant systems; however, a container of water is usually mounted on the front of the grinder.

Bench grinders usually have grinding wheels up to 8 inches in diameter and 1 inch thick. A wheel guard encircles the grinding wheel except for the work area. An adjustable toolrest steadies the workpiece. You can move it in or out or swivel it to adjust to grinding wheels of different diameters. An adjustable eyeshield made of safety glass should be mounted on the upper part of the wheel guard. Position this shield to deflect the grinding wheel particles away from you.

Pedestal grinders (fig. 5-2) are usually heavy-duty bench grinders mounted on a pedestal fastened to the deck. They usually have the features of a bench grinder plus a coolant system, which includes a pump, storage sump, hose, and fittings to regulate and carry the coolant to the wheel surface.

## GRINDING WHEELS

A grinding wheel is made of two basic elements: (1) the abrasive grains, and (2) the bonding agent. You can think of the abrasive grains as many



28.61

Figure 5-2.—Grinding on a pedestal grinder.

single-point tools embedded in a toolholder or bonding agent. Each of these grains removes a very small chip from the workpiece as it makes contact on each revolution of the grinding wheel.

An ideal cutting tool is one that will sharpen itself when it becomes dull. This, in effect, happens to the abrasive grains. As the individual grains become dull, the pressure on them causes them to fracture and present new sharp cutting edges to the work. When the grains can fracture no more, the pressure becomes too great and they are released from the bond, allowing a new layer of sharp grains to contact the work.

## SIZES AND SHAPES

The size of a grinding wheel is determined by its diameter in inches, the diameter of its spindle hole, and the width of its face. Grinding wheels have too many shapes to list in this manual, but figure 5-3 shows those used most often. The type numbers are standard and all manufacturers use them. The shapes are shown in cross-sectional views. The job will dictate the shape you should use.

## WHEEL MARKINGS AND COMPOSITION

Grinding wheel markings are composed of six stations, each of which identifies a characteristic of

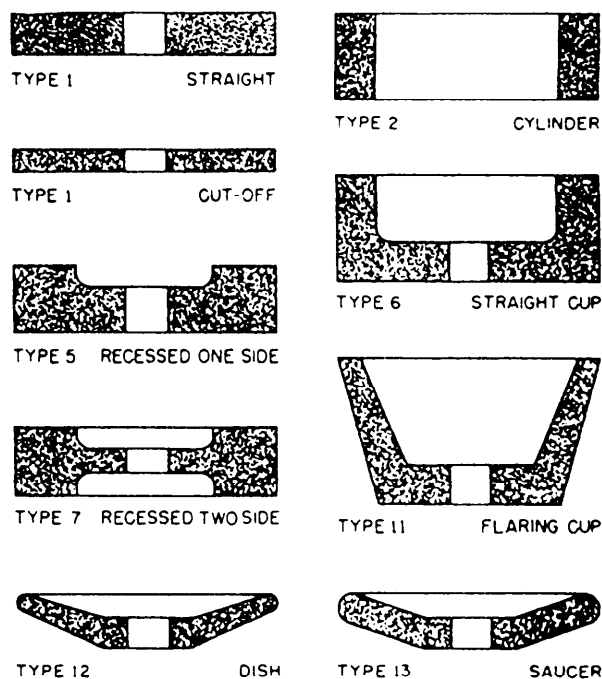


Figure 5-3.—Grinding wheel shapes.

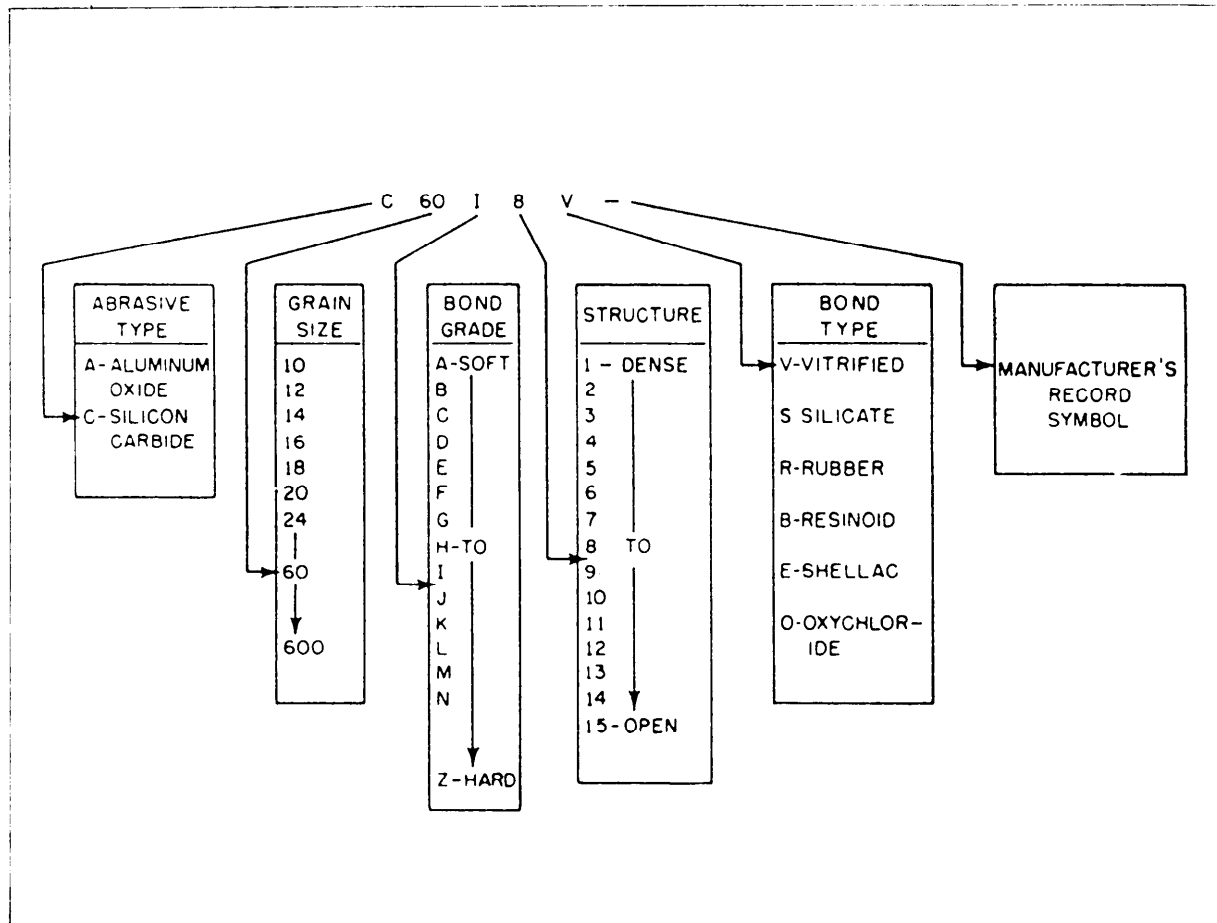


Figure 5-4.—Standard marking system for grinding wheels (except diamond).

the wheel. Since different grinding jobs require different abrasives, you should learn this identification system so you can identify the grinding wheel you need for a given job. The six stations are (1) type of abrasive, (2) grain size, (3) bond grade, (4) structure, (5) type of bond, and (6) the manufacturer's record symbol. Figure 5-4 shows the six stations that identify nearly all abrasives except diamond, which we'll explain in later paragraphs. Follow the stations in the figure from left to right as you read an explanation of each station in the following paragraphs:

1. Type of abrasive: There are two types of abrasives: natural and manufactured. Natural abrasives, such as emery, corundum, and diamond, are used only in honing stones and in special types of grinding wheels. The common manufactured abrasives are aluminum oxide and silicon carbide. They have superior qualities and are more economical than natural abrasives. Aluminum oxide (designated by the letter A in station 1) is used to grind steel and steel alloys and for heavy duty work such as to clean

up steel castings. Silicon carbide (designated by the letter C in station 1) is harder but not as tough as aluminum oxide. It's used mostly to grind nonferrous metals and carbide tools. The abrasive in a grinding wheel makes up about 40 percent of the wheel.

2. Grain size: Grain sizes range from 10 to 500. The size is determined by the size of mesh of a sieve through which the grains can pass. Grain size is rated as follows: coarse: 10, 12, 14, 16, 18, 20, 24; medium: 30, 36, 46, 54, 60; fine: 70, 80, 90, 100, 120, 150, 180; and very fine: 220, 240, 280, 320, 400, 500, 600. Fine grain wheels are preferred to grind hard materials—they have more cutting edges and will cut faster than coarse grain wheels. Coarse grain wheels are generally preferred to remove metal quickly from softer materials.

3. Bond grade (hardness): The bond grade runs from A to Z, (soft to hard). It's a measure of the bond's ability to hold the abrasive grains in the wheel. A grade of soft or hard does not mean that the bond or

the abrasive is soft or hard; it means that the wheel has either a small amount of bond (soft grade) or a large amount of bond (hard grade). Figure 5-5 shows magnified portions of both soft-grade and hard-grade wheels. You can see that a part of the bond surrounds the abrasive grains, and the remainder of the bond forms into posts that hold the grains to the wheel and hold them apart from each other. The wheel with the larger amount of bonding material (hard grade) has thick bond posts and offers great resistance to grinding pressures. The wheel with the least amount of bond (soft grade) offers less resistance.

4. Structure: The structure is designated by numbers from 1 to 15. It refers to the open space between the grains, as shown in figure 5-5. Wheels with grains that are very closely spaced are said to be dense; when grains are wider apart, the wheels are said to be open. Open-grain wheels will remove more metal faster than close-grain wheels. Also, dense, or close grain, wheels normally produce a finer finish. Structure makes up about 20 percent of the grinding wheel.

5. Bond type: The bond makes up the remaining 40 percent of the grinding wheel and is one of its most important parts. The bond determines the strength of the wheel. The five basic types of bond are vitrified, silicate, rubber, resinoid, and shellac. We will describe each of them in the following paragraphs:

- Vitrified bond is designated by the letter *V*. About 75 percent of all grinding wheels are made with vitrified bond. It is not affected by oil, acid, or water. Vitrified bond wheels are strong and porous, and rapid temperature changes have little effect on them. Vitrified bond is composed of special clays. When heated to approximately 2300°F, the clays form a glasslike cement. Do NOT run vitrified bond wheels faster than 6,500 surface feet per minute (sfpm).

- Silicate bond is designated by the letter *S*. This bond is made of silicate of soda. Silicate bond wheels are used mainly on large, slow rpm machines where a cooler cutting action is wanted. Silicate bond wheels are softer than vitrified wheels, and they release the grains more readily. Silicate bond wheels are heated to approximately 500°F when they are made. Like the vitrified bond wheel, do not run this one at a speed greater than 6,500 sfpm.

- Rubber bond wheels are designated by the letter *R*. The bond consists of rubber with sulphur added as a vulcanizing agent. The bond is made into a sheet into which the grains are rolled. The wheel is

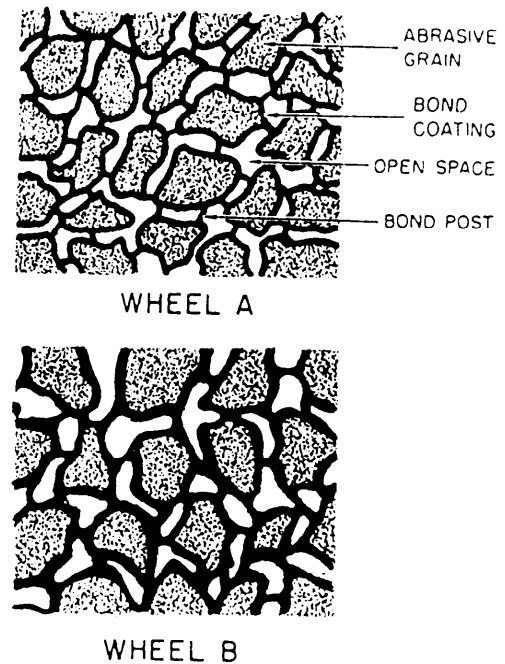


Figure 5-5.—How bond affects the grade of the wheel. Wheel A, softer; wheel B, harder.

stamped out of this sheet and heated in a pressurized mold until the vulcanizing action is complete. These wheels are very strong and elastic, and they are used as thin cutoff wheels. They produce a high finish and you can run them at speeds between 9,500 and 16,000 sfpm.

- Resinoid bond wheels are designated by the letter *B*. Resinoid bond is made from powdered or liquid resin with a plasticizer added. The wheels are pressed and molded to size and fired at approximately 320°F. The wheels are shock resistant and very strong and they are used for rough grinding and as cutoff wheels. Like rubber bond wheels, you can run these wheels at a speed of 9,500 to 16,000 sfpm.

- Shellac bond wheels are designated by the letter *E*. They are made from a secretion from Lac bugs. The abrasive and bond are mixed, molded to shape, and baked at approximately 300°F. Shellac bond wheels give a high finish and have a cool cutting action when used as cutoff wheels. You also can run these wheels at speeds between 9,500 and 12,500 sfpm.

6. Manufacturer's Record Symbol: The sixth station of the grinding wheel marking is the manufacturer's record. This may be a letter or number, or both. The manufacturer uses it to designate bond modifications or wheel characteristics.



## DIAMOND WHEELS

Diamond grinding wheels are classed by themselves. They can be made from natural or manufactured diamonds, and they are very expensive. Their cutting speeds range from 4,500 to 6,000 surface feet per minute. Use them with care and only to grind carbide cutting tools. They are marked similarly to aluminum-oxide and silicon-carbide wheels, although there is not a standard system. The usual diamond abrasive wheel identification system uses seven stations as follows:

1. Type of abrasive, designated D for natural and SD for manufactured.
2. Grit size, which can range from 24 to 500. A 100-grain size might be used for rough work, and a 220 for finish work. In a Navy machine shop, you might find a 150-grain wheel and use it for both rough and finish grinding.
3. Grade, designated by letters of the alphabet.
4. Concentration, designated by numbers. The concentration, or proportion of diamonds to bond, might be numbered 25, 50, 75, or 100, going from low to high.
5. Bond type, designated B for resinoid, M for metal, and V for vitrified.
6. Bond modification (This station may or may not be used).
7. Depth of the diamond section. This is the thickness of the abrasive layer and ranges from 1/32 to 1/4 inch. Cutting speeds range from 4,500 to 6,000 surface feet per minute.

## GRINDING WHEEL SELECTION AND USE

You should select a grinding wheel that has the proper abrasive, grain, grade, and bond for the job. Base your selection on such factors as the physical properties of the material to be ground, the amount of stock to be removed (depth of cut), the wheel speed and work speed, and the finish required.

To grind carbon and alloy steel, high-speed steel, cast alloys and malleable iron, you probably should use an aluminum oxide wheel. Silicon carbide is the most suitable for nonferrous metals, nonmetallic materials, and cemented carbides.

Generally, you'll choose coarser grain wheels to grind softer and more ductile materials. Also use

coarse-grain wheels to remove a large amount of material (except on very hard materials). If you need a good finish, use a fine grain wheel. If the machine you are using is worn, you may need to use a harder grade wheel to offset the effects of that wear. You also can use harder grade wheel if you use a coolant with it. Refer to your machine's operators manual to select grinding wheels for various operations.

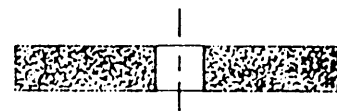
Figure 5-6 shows the type of grinding wheel used on bench and pedestal grinders. When you replace the wheel, be sure the physical dimensions of the new wheel are correct for the grinder. Check the outside diameter, the thickness, and the spindle hole. If necessary, use an adapter (bushing) to decrease the size of the spindle hole so it fits your grinder.

You should use A3605V (coarse) and A60M5V (fine or finish) wheels to grind or sharpen single point tool bits such as those for a lathe, planer, or shaper made from high-carbon or high-speed steel. Use an A46N5V wheel for stellite tools. These wheels have aluminum oxide as an abrasive material; use them to grind steel and steel alloys only. If you use them on cast iron, nonferrous metal, or nonmetallic materials, you may load or pin the wheel when particles of the material are imbedded in the wheel's pores. This strains the wheel and could cause it to fail and possibly injure someone.

## WHEEL INSTALLATION

You must install the wheel of a bench or pedestal grinder properly or it will not operate properly and may cause accidents. Before you install a wheel, inspect it for visible defects and "sound" it to learn if it has invisible cracks.

To sound a wheel, hold it up by placing a hammer handle or a short piece of cord through the spindle hole. Use a nonmetallic object such as a screwdriver handle or small wooden mallet to tap the wheel lightly on its side. Rotate the wheel 1/4 of a turn (90°) and repeat the test. A good wheel will give out a clear ringing sound. If you hear a dull thud, the wheel is cracked and should not be used.



STRAIGHT WHEEL

Figure 5-6.—Grinding wheel for bench and pedestal grinders.

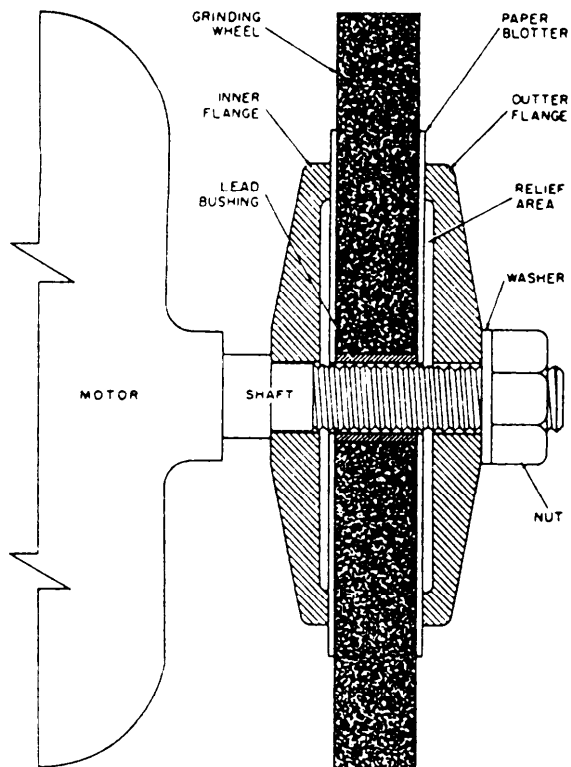


Figure 5-7.—Method of mounting a grinding wheel.

Look at figure 5-7 as you read the following explanation about wheel installation. Note that blotters are used on both sides of a wheel. A blotter ensures even pressure on the wheel and dampens the vibration between the wheel and the shaft. A paper blotter may be no more than 0.0025 inch thick and a leather or rubber blotter no more than 0.125 inch.

1. Be sure the shaft and flanges are clean and free of grit and old blotter material. Place the inner flange in place and follow it with a blotter.

2. Mount the wheel against the inner blotter and be sure it fits on the shaft without play. There should be a 0.002- to 0.005-inch clearance. You may need to scrape or ream the lead bushing in the center of the wheel to get this clearance. **NEVER FORCE THE WHEEL ONTO THE SHAFT.** You may force the wheel out of axial alignment or cause it to crack when it is used.

3. Install the second blotter, followed by the outer flange. Note that the flanges are recessed so they provide an even pressure on the wheel. The flanges should be at least one-third the diameter of the wheel.

4. Install the washer and secure the nut. Tighten the nut enough to hold the wheel firmly; if you tighten it too much, you may damage the wheel.

## TRUING AND DRESSING THE WHEEL

Grinding wheels, like other cutting tools, require frequent reconditioning of cutting surfaces to perform efficiently. Dressing is the process of cleaning their cutting faces. This cleaning breaks away dull abrasive grains and smooths the surface so that there are no grooves. Truing is the removal of material from the cutting face of the wheel so that the surface runs absolutely true to some other surface such as the grinding wheel shaft.

Use the wheel dresser shown in figure 5-8 to dress grinding wheels on bench and pedestal grinders. To dress a wheel with this tool, start the grinder and let it come up to speed. Set the wheel dresser on the rest as shown in figure 5-8 and bring it in firm contact with the wheel. Move the wheel dresser across the periphery of the wheel until the surface is clean and approximately square with the sides of the wheel.

Several things can get a grinding wheel out of balance. For instance, it may be out of round, and you can usually correct the problem by dressing the wheel. Or, it may get out of balance if part of the wheel is immersed in coolant. If this happens, remove the wheel and bake it dry. If the wheel gets out of balance axially, it probably will not affect the efficiency of the wheel on bench and pedestal grinders. To correct axial unbalance, remove the wheel and clean the shaft spindle, the hole, and the flanges.

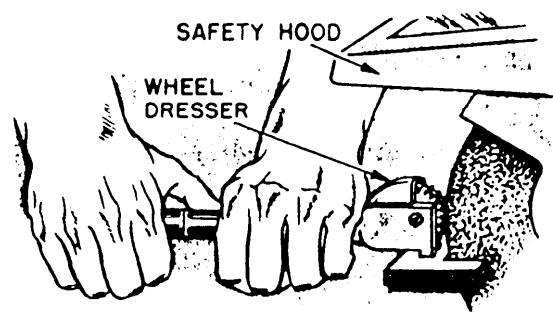


Figure 5-8.—Using a grinding wheel dresser.

## WHEEL CARE AND STORAGE

It's easy to damage or break grinding wheels if you mishandle them or store them improperly. Whenever you handle them, take care not to drop them or bump them against other hard objects.

Store grinding wheels in a cabinet or on shelves large enough to allow selection of a wheel without disturbing the other wheels. The storage space should protect against high humidity, contact with liquids, freezing temperatures, and extreme temperature changes. Also secure grinding wheels aboard ship to prevent them from being damaged when the ship is at sea. Stack thin cutoff wheels on a rigid surface without any separators or blotters between them. Stack flaring cup wheels flat with the small ends together. Store all other types of wheels upright on their rims with blotters between them. A sheet metal cabinet lined with felt or corrugated cardboard to prevent wheel chipping makes good storage.

## CARBIDE TOOL GRINDER

The carbide tool grinder (fig. 5-9) looks much like a pedestal grinder with the toolrest on the side instead of the front. The main components of the carbide tool grinder are a motor with the shaft extended at each end to mount the grinding wheels, the pedestal that supports the motor and is fastened to the deck, wheel guards mounted around the

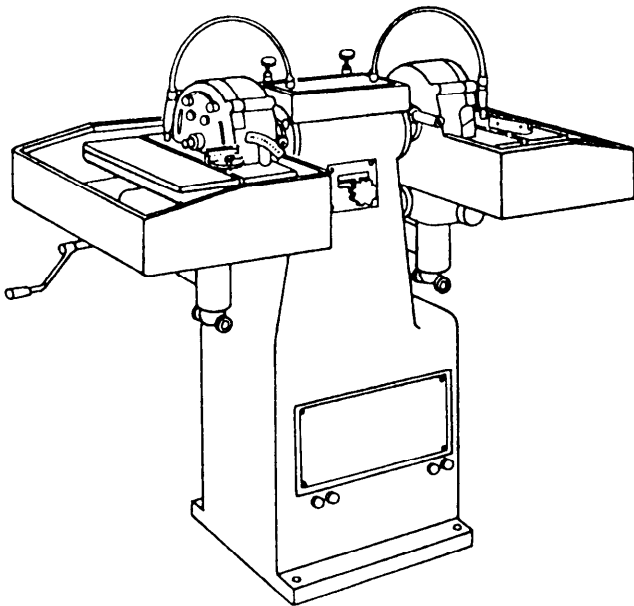


Figure 5-9.—Carbide tool grinder.

circumference and back of the grinding wheels as a safety device, and an adjustable toolrest mounted in front of each wheel to support the tool bits while they are being ground.

While you grind on the periphery of the wheel on a pedestal grinder, you will grind on the side of the wheel on a carbide tool bit grinder. The straight cup wheel (fig. 5-10) is similar to the wheels used on most carbide tool bit grinders. Some carbide tool grinders have a straight cup wheel on one side of the grinder and a straight wheel, such as the type used on a pedestal or bench grinder, on the other side.

The adjustable toolrest has an accurately ground groove or keyway across the top of its table. This groove holds a protractor attachment that you can set to the desired cutting edge angle. The toolrest will also adjust to permit grinding the relief angle.

If your carbide tool grinder has a coolant system, be sure you direct an ample, steady stream of coolant at the point where the tool meets the wheel. An irregular flow may allow the tool to heat up and then be quenched quickly, which may crack the carbide. If your grinder has no coolant system, let the carbide cool in the air; do **NOT** dip it in water when it becomes hot.

Carbide-tipped tool bits may have either disposable or brazed cutting edges. The disposable-tip tool bit needs no sharpening; just dispose of the tips when their cutting edges become dull. Sharpen the brazed-tip tool bit on the carbide tool bit grinder.

For best results with carbide-tipped tool bits, use a silicon-carbide wheel for roughing and a diamond impregnated wheel for finishing.

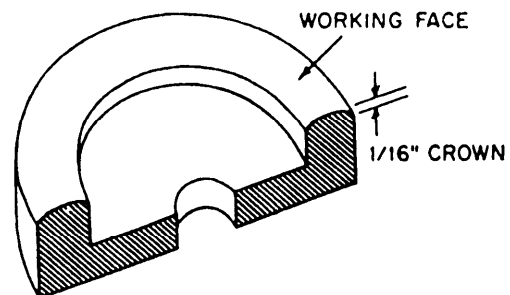


Figure 5-10.—Crown on the working face of a wheel for a carbide tool bit grinder.

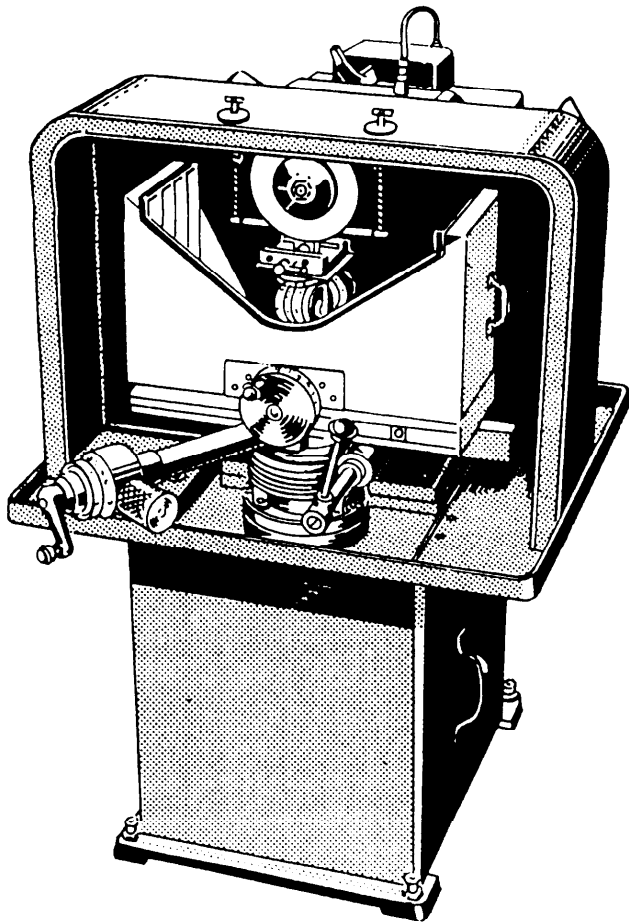


Figure 5-11.—Chip breaker grinder.

### CHIPBREAKER GRINDER

A chip breaker grinder (fig. 5-11) is a specialized grinding machine. It grinds grooves or indentations on the top surface of carbide tools to control the direction and length of the chips produced in cutting metal. Later in this chapter, we'll describe the types of chip breakers that are commonly ground on carbide tools.

The chip breaker grinder has a vise you can adjust to four different angles to hold the tool to be ground. These angles are the side cutting edge, back rake, side rake, and chip breaker, and we'll explain them later in this chapter. The vise is mounted so you can move it back and forth under the grinding wheel. Both the cross feed used to position the tool under the grinding wheel and the vertical feed used to control the depth of the chip breaker are graduated in increments of 0.001 inch.

The chip breaker grinder uses a diamond wheel. It is usually a type 1 straight wheel but differs from other type 1 wheels because it is normally less than

1/4 inch thick. An SD150R100B grinding wheel is normally recommended.

Chip breaker grinders have a coolant system that either floods or slowly drips coolant onto the tool being ground. The main objective is to prevent the grinding wheel from loading up or glazing over from the grinding operation.

### CUTTING TOOL MATERIALS

The materials used to make machine cutting tools must be hard enough to cut other metals, be wear resistant, have impact strength to resist fracture, and keep their hardness and cutting edge at high temperatures. Several different materials are used for cutting tools, and each one has properties different from the others. Selection of a cutting tool material depends upon the metal to be cut and the conditions under which it will be cut.

### HIGH-SPEED STEEL

High-speed steel is a widely used cutting tool material. High-speed steel tools can maintain their hardness and abrasion resistance under the high temperatures and pressures generated during the general cutting process. Although the hardness of a high-speed tool (Rc 60-70) is not much greater than that of carbon-steel tools, high-speed steel begins to lose its hardness at a tempering temperature of 1,000° to 1,100°F. Machine shops generally use two types of high-speed tools: tungsten high-speed steel and molybdenum high-speed steel. These designations show the major alloying element in each of the two types. Both types resist abrasive wear, remain hard at high temperatures, and keep a similar degree of hardness. The molybdenum high-speed steel is tougher than the tungsten and is more effective in machinery operations where interrupted cuts are made. In an interrupted cut, such as cutting out-of-round or slotted material, the cutter contacts the material many times in a short period of time. This "hammering" effect dulls or breaks cutters that are not tough enough to withstand the shock effect.

### CAST ALLOYS

Cast alloy tool steel usually contains varying amounts of cobalt, chrome, tungsten, and molybdenum. Tools made from these steels are generally more efficient than tools made from high-speed steel, retaining their hardness up to an operating temperature of approximately 1,400°F. This characteristic

allows cutting speeds approximately 60 percent greater than for high-speed steel tools. However, cast alloy tools are not as tough as the high-speed steel tools and they cannot bear the same cutting stresses, such as interrupted cuts. Clearances ground on cast alloy cutting tools are less than those ground on high-speed steel tools because of the lower degree of toughness. Tools made from this metal are generally known as Stellite, Rexalloy, and Tantung.

## **CEMENTED CARBIDE**

A carbide, generally, is a chemical compound of carbon and metal. The term commonly refers to cemented carbides, the cutting tools made of tungsten carbide, titanium carbide, or tantalum carbide, and cobalt in various combinations. A typical composition of cemented carbide is 85 to 95 percent carbides of tungsten and the remainder a cobalt binder for the tungsten carbide powder.

Cemented carbides are made by compressing various metal powders and sintering (heating to weld particles together without melting them) the briquettes. Cobalt powder is used as a binder for the carbide powder.

Carbides have greater hardness at both high and low temperatures than high-speed or cast alloys. At temperatures of 1,400°F and higher, carbides maintain the hardness required for efficient machining. This makes possible machining speeds of approximately 400 fpm in steels. The addition of tantalum increases the red hardness of a tool material. Cemented carbides are extremely hard tool materials (above Rc90), have a high compressive strength, and resist wear and rupture.

Cemented carbides are the most widely used tool material in the machining industry. They are particularly useful for cutting tough alloy steels that quickly break down high-speed tool steels. Various carbide grades and insert shapes are available and you should make the correct selection to machine a particular material. We'll now briefly discuss brazed-on tip carbides. Since mechanically-held tip (insert type) carbides are more widely used, we will discuss them in more depth later in the chapter.

### **Brazed-on Tip**

The brazed-on carbide-tip cutting tool was the first carbide cutting tool developed and made available to the metal cutting industry. A brazed-on tip can be easily ground to machine such jobs. The

various styles of tools required in machinery, such as turning, facing, threading, and grooving are available with different grades of carbide tips already brazed onto steel shanks. You can also get small carbide blanks and have them brazed onto shanks.

When you use cutting tools with brazed-on carbide tips, chip control may be provided by either feeds and speeds or by chip breaker grooves ground into the top of the carbide tip. The best way to grind a chip breaker is to use a chip breaker grinder with a diamond impregnated wheel. The depth of the chip breakers averages about 1/32 inch, while the width varies with the feed rate, depth of cut and material being cut. Grind the chip breaker narrow at first and widen it if the chip does not curl and break quickly enough. You may also use these same types of chip breakers on high-speed steel cutters.

### **Mechanically Held Tip (Insert Type)**

Mechanically held carbide inserts are available in several different shapes—round, square, triangular, diamond threading, and grooving—and in different thicknesses, sizes, and nose radii. In the following paragraphs, we'll discuss the most important criteria you'll need to select an insert.

**OPERATING CONDITIONS.**—You must use three variables to establish metal removal rate: speed, feed, and depth of cut. Cutting speed has the greatest effect on tool life. A 50 percent increase in cutting speed will decrease tool life by 80 percent. A 50 percent increase in feed will decrease tool life by 60 percent. The cutting edge engagement or depth of cut is limited by the size and thickness of the carbide insert and the hardness of the material being machined. Hard materials require decreased feed, speed, and depth of cut. The depth of cut is limited by the strength and thickness of the carbide insert, the rigidity of the machine and setup, the horsepower of the machine, and the amount of material to be removed.

Edge wear and cratering are the most frequent tool breakdowns and they occur when friction and abrasion break down the tool relief surface. They are also caused by the tearing away of minute carbide particles from the built-up edge. The cutting edge is usually chipped or broken in this case. Lack of rigidity, too much feed, or too slow a speed causes chipped or broken inserts.

Thermal shock is caused by sudden heating and cooling that causes a tool to crack, then break. This

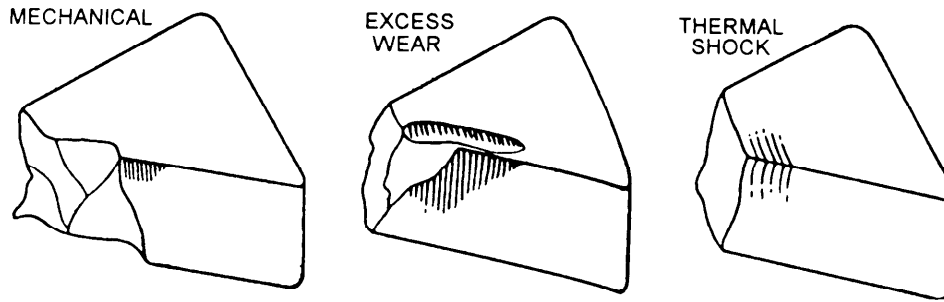


Figure 5-12.—Three causes of tool breakage.

most likely will occur when an inadequate amount of coolant is used. If you can't keep the work and tool flooded with coolant, it's usually better to machine dry.

Figure 5-12 shows three of the causes of tool breakage.

The following list shows some of the things you can do to overcome the problems of tool edge breakdown:

If edge wear occurs:

- Decrease machining speed.
- Increase feed.
- Change to a harder, more wear-resistant carbide grade.

If the cutting edge is chipped or broken:

- Increase speed.
- Decrease feed and/or depth of cut.
- Change to a tougher grade carbide insert.
- Use negative rake.
- Hone the cutting edge before use.
- Check the rigidity and tooling overhang.

When there is buildup on the cutting edge.

- Increase speed.
- Change to a positive rake tool.
- Change to a grade containing titanium.
- Increase the side cutting edge angle.
- Decrease feed.

**CEMENTED CARBIDE GRADES.**—Cemented carbides have been organized into grades. Properties

that determine grade include hardness, toughness, and resistance to chip welding or cracking. The properties of carbide tools may vary by the percentages of cobalt and titanium or tantalum carbides. Properties may also vary during the processing by the grain size of carbides, density, and other modifications. Some tungsten carbide inserts are given a titanium carbide coating (about 0.0003 in. thick) to help them resist cratering and edge breakdown.

The grades of carbides have been organized according to their suitable uses by the *Cemented Carbide Producers Association* (CCPA). When you select a carbide, use a table made up of those suitable uses rather than make your choice based on composition. The following list shows cemented carbide grades with specific chip removal applications:

C-1	Roughing cuts (cast iron and nonferrous materials)
C-2	General purpose (cast iron and nonferrous materials)
C-3	Light finishing (cast iron and nonferrous materials)
C-4	Precision boring (cast iron and nonferrous materials)
C-5	Roughing cuts (steel)
C-6	General purpose (steel)
C-7	Finishing cuts (steel)
C-8	Precision boring (steel)

The hardest of the nonferrous/cast iron grades is C-4 and the hardest of the steel grades is C-8. This system does not specify the particular materials, alloy, or machining operations. It combines experience gained from using carbides and manufacturer's recommendations to select the proper grade of carbide.

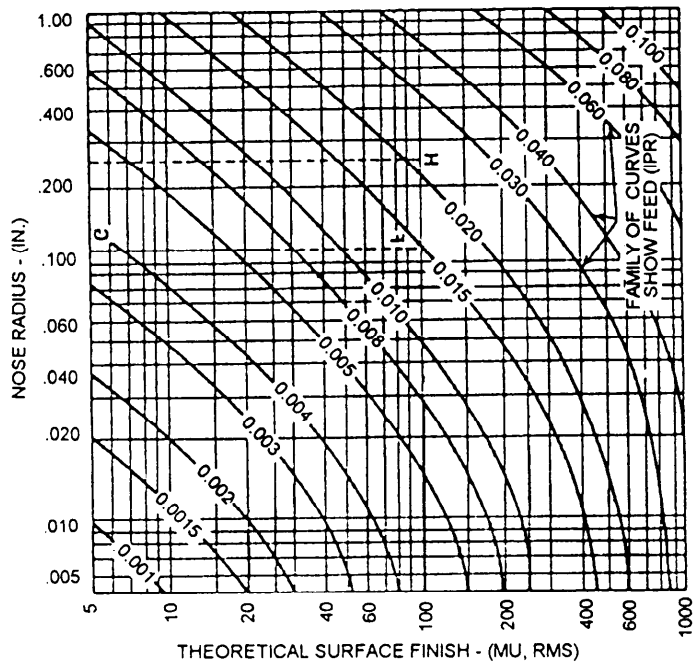


Figure 5-13.—Surface finish vs nose radius chart.

**NOSE RADIUS.**—Selecting the nose radius can be important because of tool strength, surface finish, or perhaps the need to form a fillet or radius on the work. To determine the nose radius according to strength requirements, use the chart shown in figure 5-13. Consider that the feed rate, depth of cut, and workpiece condition determine strength requirements.

Large radii are strongest and can produce the best finishes, but they also can cause chatter between tool and workpiece. For example, the dashed line on the chart shows that a 1/8-inch radius would be required

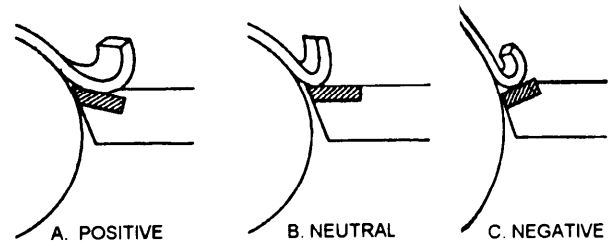


Figure 5-15.—Side view of rake angles.

for turning at a feed rate of 0.015 inch to obtain a 100 microinch finish. A 1/4-inch radius would be required with a 0.020-inch feed rate.

**INSERT SHAPES.**—Indexable inserts (fig. 5-14) are clamped in toolholders of various designs. Each of these inserts has several cutting edges. After you have used all of the edges, discard the insert.

Round inserts have the greatest strength and, like large radius inserts, they offer higher feed rates with equal finishes.

Square inserts have lower strength and fewer possible cutting edges than round tools, but they are much stronger than triangular inserts

Triangular inserts have the greatest versatility. For example, you can use them in combination turning and facing operations where round or square inserts are often not adaptable to such combinations. Because the included angle between cutting edges is less than 90°, you also can use triangular inserts for tracing operations. The main disadvantages are their reduced strength and fewer cutting edges per insert.

**RAKE ANGLE.**—When selecting rake angles (fig. 5-15), you need to consider the machining conditions. Use negative rake where there is maximum

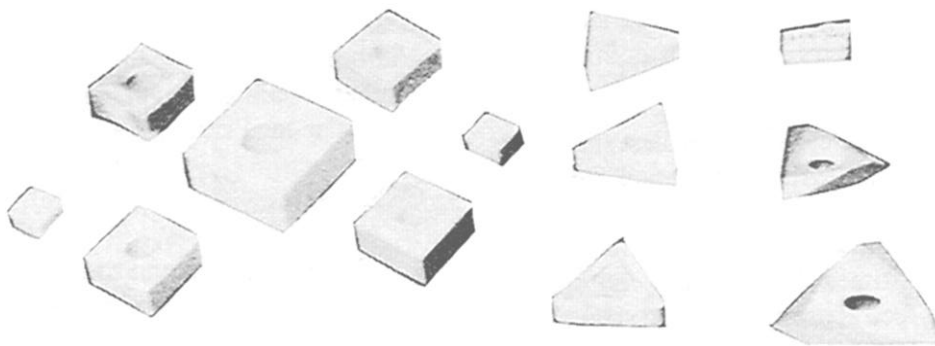
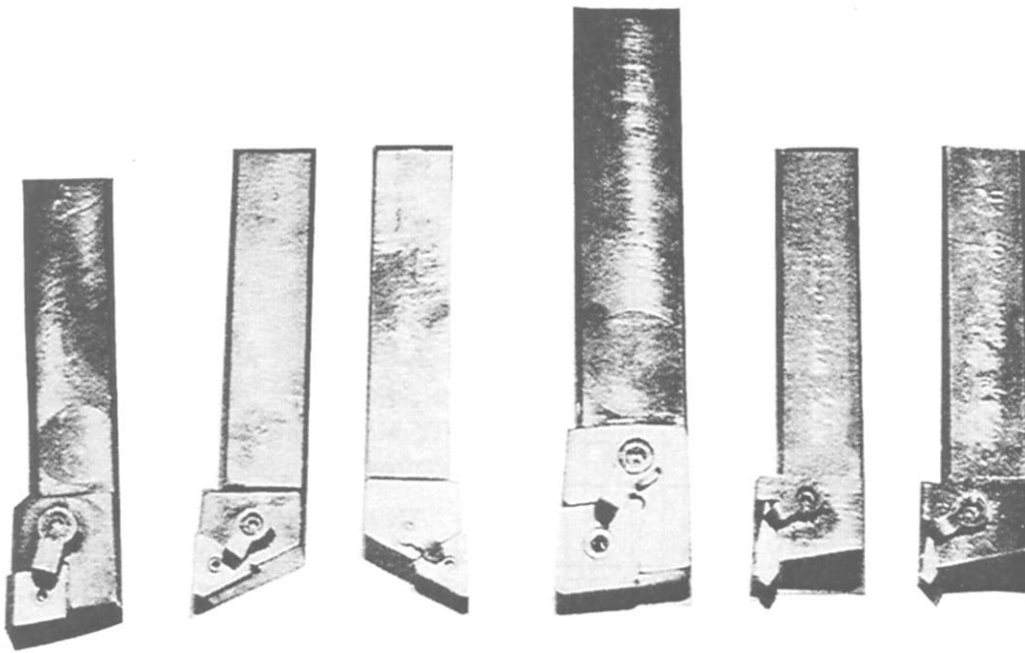


Figure 5-14.—Indexable inserts.



28.480

Figure 5-16.—Toolholders for carbide inserts.

rigidity of the tool and work and where you can maintain high machining speeds. Negative rake tools require more horsepower. Under these conditions, negative rake tools are stronger and produce satisfactory results.

You may use negative rake inserts on both sides, doubling the number of cutting edges per insert. This is possible because end and side relief are provided by the angle of the toolholder rather than by the shape of the insert.

Use positive rake inserts where rigidity of the tool and work is reduced and where high cutting speeds are not possible; for example, on a flexible shaft of small diameter. Positive rake tools cut with less force so deflection of the work and toolholder should be reduced. High cutting speeds (sfpm) are often not possible on small diameters because of limitations in spindle speeds.

**INSERT SIZES.**—Select the smallest insert that can sustain the required depth of cut and feed rate. The depth of cut should always be as great as possible. The rule of thumb is to select an insert with cutting edges  $1 \frac{1}{2}$  times the length of cutting edge engagement. The feed for roughing mild steel should be approximately  $1/10$  the depth of cut.

**TOOLHOLDER AND BORING BAR STYLES.**—Tool style pertains to the configuration of toolholders and boring bars used to hold a carbide

insert. To determine style, you need to know something about the particular machine tool you are using and the operations you will do on it. Figures 5-16 and 5-17 show some of the styles available for toolholders and boring bars.

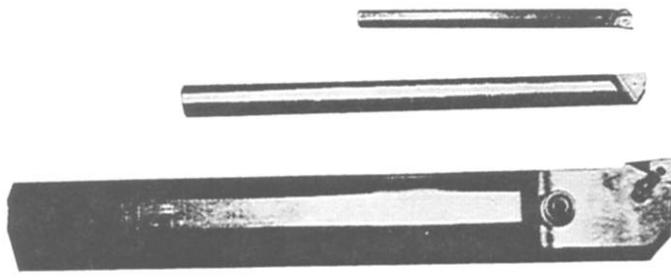
**TOOLHOLDER AND CARBIDE INSERT IDENTIFICATION.**—The carbide and toolholder manufacturers and the *American Standards Association* (ASA) have adopted a system to identify toolholders and inserted carbides. The system is used to call out the toolholder geometry and to identify inserts. You'll find these charts in manufacturer's catalogs; copy them and keep them in your toolbox.

We have given you an overview on carbides; certainly not everything you need to know. You also must work with personnel who know how to use them and then learn by using them yourself. Also, a number of carbide manufacturers offer schools to help you understand carbides and their uses.

## CERAMIC

Other than diamond tools, ceramic cutting tools are the hardest and most heat resistant available to the machinist. A ceramic cutting tool can machine metals that are too hard for carbide tools, and they can sustain cutting temperatures up to  $2,000^{\circ}\text{F}$ . Therefore, you can use ceramic tools at cutting speeds two to four times greater than cemented carbide tools.





28.481

Figure 5-17.—Boring bars for carbide inserts.

Ceramic cutting tools are available as either solid ceramic or as ceramic coated carbide. They come in several of the insert shapes available in cemented carbides and they are secured in the toolholder by a clamp.

Whenever you handle ceramic cutting tools, be very careful because they are very brittle and will not tolerate shock or vibration. Be sure your lathe setup is very rigid and do not take interrupted cuts. Also be sure the lathe feed rate does not exceed 0.015 to 0.020

inch per revolution. Any greater rate will subject, the insert to excessive forces and may cause it to fracture.

### GROUND SINGLE-POINT, HIGH-SPEED CUTTING TOOLS

A single-point or single-edged cutting tool has only one cutting edge as opposed to two or more on other tools. Drill bits are multiple-edged cutters; most lathe tools are single edged. To properly grind a single-point cutting tool, you must know the relief angles, the rake angles, and the cutting edge angles that are required for specific machines and materials. You also must know what materials are generally used as cutting tools and how tools for various machines differ.

### CUTTING TOOL TERMINOLOGY

Figure 5-18 shows the application of the angles and surfaces we use to discuss single-point cutting tools. Notice there are two relief angles and two rake angles and that the angle of keenness is formed by grinding a rake angle and a relief angle. We'll discuss

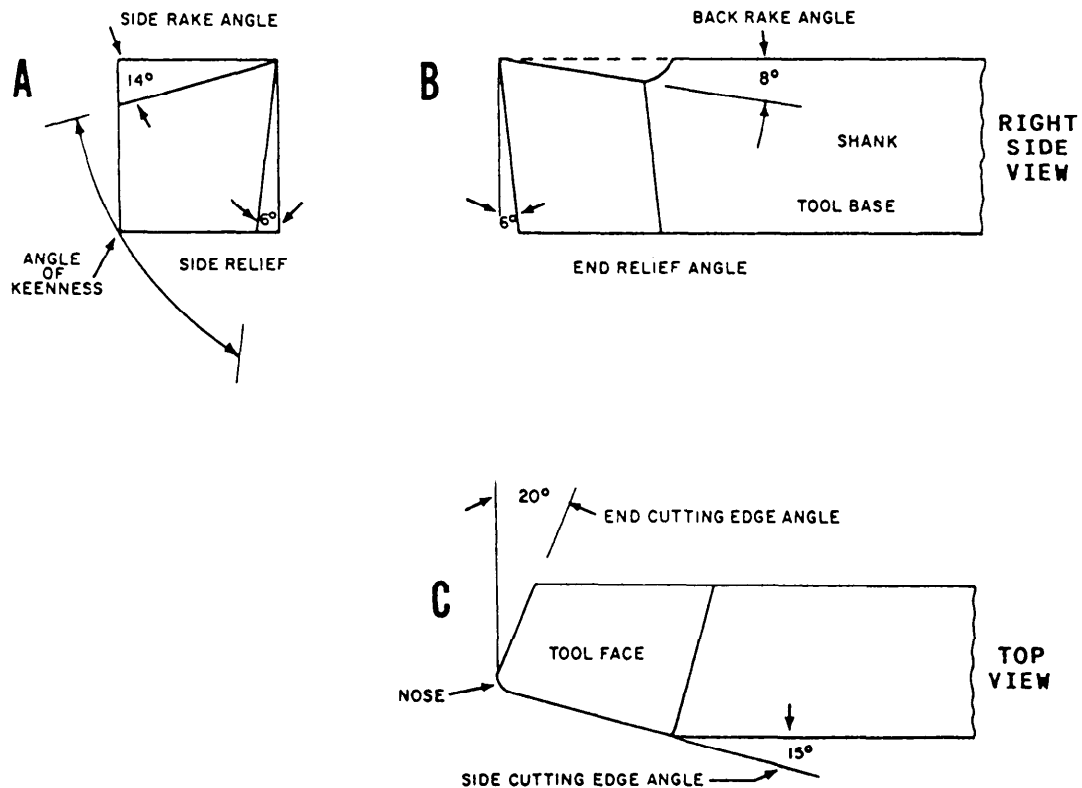


Figure 5-18.—Applications of tool terminology.

the angles that have to be ground on a high-speed single-point cutting tool in the following paragraphs.

### **Side Rake**

Side rake is the angle at which the top surface of the tool bit is ground away making a slope either away from or toward the side cutting edge. Figure 5-18, view A, shows a positive side rake angle. When the side rake is ground toward the side cutting edge, the side rake has a negative angle. The amount of side rake influences to some extent the size of the angle of keenness. It causes the chip to “flow” to the side of the tool away from the side cutting edge. A positive side rake is most often used on ground single-point tools. Generally, the side rake angle will be steeper (in the positive direction) to cut the softer metals and will decrease as the hardness of the metal increases. A steep side rake angle in the positive direction causes the chip produced in cutting to be long and stringy. Decreasing the angle will cause the chip to curl up and break more quickly. A negative side rake is recommended when the tool will be subjected to shock, such as an interrupted cut or when the metal being cut is extremely hard.

### **Back Rake**

The back rake is the angle at which the top surface of the tool is ground away mainly to guide the direction of the flowing chips. It is ground primarily to cause the chip to “flow” back toward the shank of the tool. Back rake may be positive or negative. It’s positive (fig. 5-18, view B) if it slopes downward from the nose toward the shank, and it’s negative if a reverse angle is ground. The rake angles help form the angle of keenness and direct the chip flow away from the point of cutting. The same general recommendations concerning positive or negative side rake angles apply to the back rake angle.

### **Side Relief**

The side relief (fig. 5-18, view A) is the angle at which the side of the tool is ground to prevent the tool bit from rubbing into the work. The side relief angle, like the side rake angle, influences the angle of keenness. A tool with proper side relief causes the side thrust to be concentrated on the cutting edge rather than rub on the flank of the tool.

### **End Relief**

The end relief (fig. 5-18, view B) is the angle at which the end surface of the tool is ground so that the front face edge of the tool leads the front surface.

### **Angle Of Keenness**

The angle of keenness or wedge angle (fig. 5-18, view A) is formed by the side rake and the side relief ground in a tool. The angle of keenness is equal to  $90^\circ$  minus the sum of the side rake and side relief angles. Generally this angle is smaller for cutting soft materials.

### **Side Cutting Edge**

The side cutting edge angle (fig. 5-18, view C) is ground on the side of the tool that is fed into the-work. This angle can vary from  $0^\circ$  for cutting to a shoulder, up to  $30^\circ$  for straight turning. An angle of  $15^\circ$  is recommended for most rough turning operations. In turning long slender shafts, a side cutting edge angle that is too large can cause chatter. Since the pressure on the cutting edge and the heat generated by the cutting action decrease as the side cutting edge angle increases, the angle should be as large as the machining operation will allow.

### **End Cutting Edge**

The end cutting edge angle (fig. 5-18, view C) is ground on the end of the tool to permit the nose to make contact with the work without the tool dragging the surface. An angle of from  $8^\circ$  to  $30^\circ$  is commonly used, with approximately  $15^\circ$  recommended for rough turning operations. Finish operations can be made with the end cutting edge angle slightly larger. Too large an end cutting edge angle will reduce the support given the nose of the tool and could cause premature failure of the cutting edge.

### **Nose**

The nose (fig. 5-18, view C) strengthens the tip of the tool, helps to carry away the heat generated by the cutting action, and helps to obtain a good finish. A tool whose nose is ground to a straight point will fail much more rapidly than one with a slight radius or rounded end ground or honed on it. However, too large a radius will cause chatter because of excessive tool contact with the work. Normally, you should use

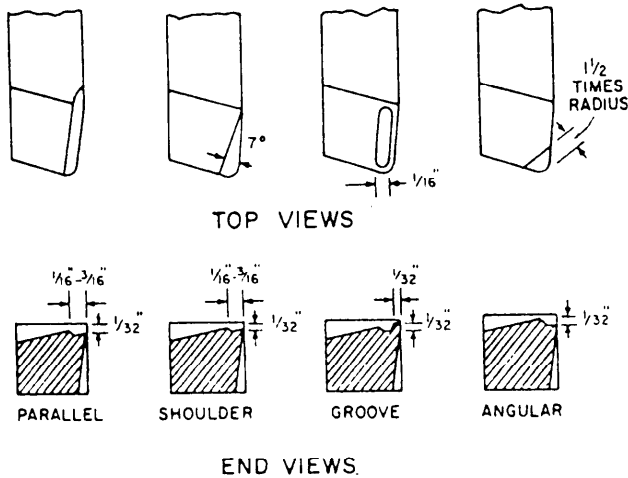


Figure 5-19.—Chip breakers.

a radius of from 1/64 to 1/32 inch in turning operations.

### GROUND-IN CHIP BREAKERS

Chip breakers are indentations ground on the top surface of the tool to reduce or prevent the formation of long and dangerous chips. The chip breaker will cause the chips to curl up and break into short, safe, manageable chips. You normally grind chip breakers on roughing tools, but you can grind them on finishing tools used to machine soft ductile metals. Figure 5-19 shows four of the several types of chip breakers.

The dimensions given are general and can be modified to compensate for the various feed rates, depths of cut, and types of material being machined. Grind the groove-type chip breaker carefully to prevent it from coming too close to the cutting edge; that reduces the life of the tool because there is less support of the cutting edge. You can use the diamond wheel on a chip breaker grinder to grind carbide-tipped tools. Grind high-speed tools with an aluminum oxide grinding wheel. You can use a bench grinder for this purpose if you dress the wheel until it has a sharp edge. Or, you can clamp the tool in a universal vise that you can set to compound angles on a surface or tool and cutter grinder.

### SHAPES OF HIGH-SPEED ENGINE LATHE CUTTING TOOLS

Figure 5-20 shows the most popular shapes of ground high-speed lathe tool cutter bits and their

applications. Each of the types shown is described in the following paragraphs:

- **Left-hand turning tool:** Grind this tool for machining work by feeding it from left to right as shown in figure 5-20, view A. The cutting edge is on the right side of the tool and the top of the tool slopes down away from the cutting edge.

- **Round-nose turning tool:** This tool is for general all-round machine work and is used to make light roughing cuts and finishing cuts. You should usually grind the top of the cutter bit with side rake so the tool may be fed from right to left. You may sometimes grind the cutter bit flat on top so you can feed the tool in either direction (fig. 5-20, view B).

- **Right-hand turning tool:** This is just the opposite of the left-hand turning tool and is designed to cut when fed from right to left (fig. 5-20, view C). The cutting edge is on the left side. This is an ideal tool for roughing cuts and general all-round machine work.

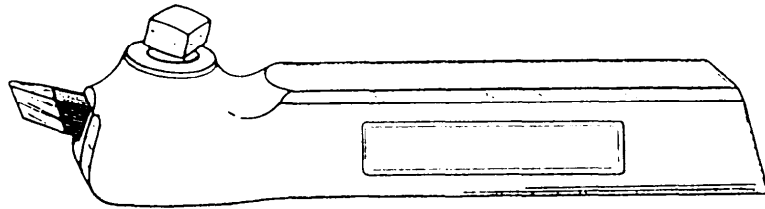
- **Left-hand facing tool:** Use this tool for facing on the left-hand side of the work as shown in figure 5-20, view D. The direction of feed is away from the lathe center. The cutting edge is on the right-hand side of the tool and the point of the tool is sharp to permit machining a square corner.

- **Threading tool:** Grind the point of the threading tool to a 60° included angle to machine V-form screw threads (fig. 5-20, view E). Usually, you should grind the top of the tool flat and leave clearance on both sides of the tool so it will cut on both sides.

- **Right-hand facing tool:** This tool is just the opposite of the left-hand facing tool. Use it to face the right end of the work and to machine the right side of a shoulder. (See fig. 5-20, view F.)

- **Square-nosed parting (cut-off) tool:** The principal cutting edge of this tool is on the front. (See fig. 5-20, view G.) Both sides of the tool must have enough clearance to prevent binding and should be ground slightly narrower at the back than at the cutting edge. Use this tool to machine necks and grooves, square corners, and to cut off.

- **Boring tool:** Usually, you should grind a boring tool in the same shape as the left-hand turning tool so the cutting edge is on the front side of the cutter bit and may be fed in toward the headstock.



LATHE TOOLHOLDER-STRAIGHT SHANK



CUTTER BIT-NOT GROUND



CUTTER BIT-GROUND TO FORM



A  
LEFT-HAND  
TURNING TOOL



B  
ROUND-NOSE  
TURNING TOOL



C  
RIGHT-HAND  
TURNING TOOL



D  
LEFT-HAND  
FACING TOOL



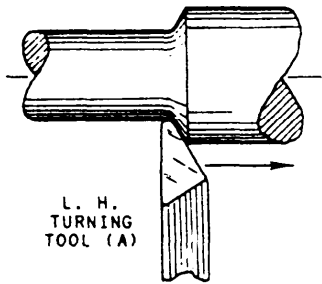
E  
THREADING  
TOOL



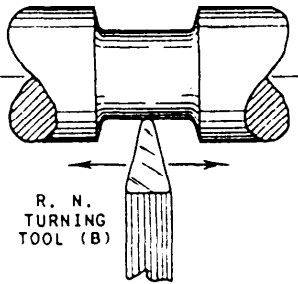
F  
RIGHT-HAND  
FACING TOOL



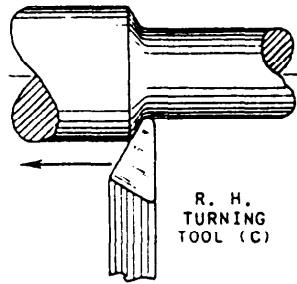
G  
CUT-OFF  
TOOL



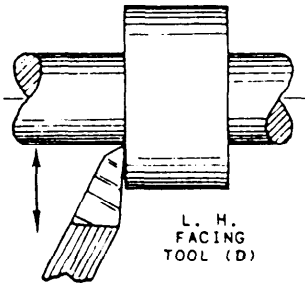
L. H.  
TURNING  
TOOL (A)



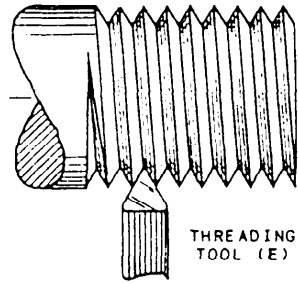
R. N.  
TURNING  
TOOL (B)



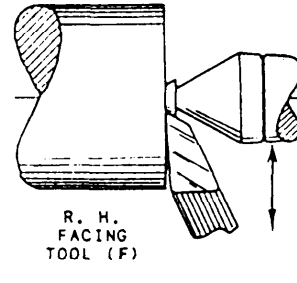
R. H.  
TURNING  
TOOL (C)



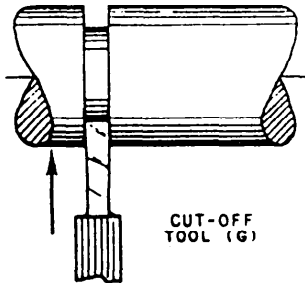
L. H.  
FACING  
TOOL (D)



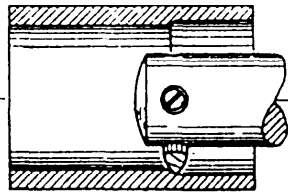
THREADING  
TOOL (E)



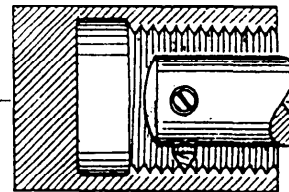
R. H.  
FACING  
TOOL (F)



CUT-OFF  
TOOL (G)



BORING  
TOOL



INSIDE  
THREADING  
TOOL

Figure 5-20.—Lathe tools and their application.

● **Internal-threading tool:** The internal-threading (inside-threading) tool is the same as the threading tool in figure 5-20, view E, except that it is usually much smaller. Boring and internal-threading tools may require larger relief angles when you use them in small diameter holes.

### GRINDING HIGH-SPEED ENGINE LATHE CUTTING TOOLS

Machining techniques and the materials being machined limit the angles of a tool bit. However, when grinding the angles, you also must consider the type of toolholder and the position of the tool with respect to the axis of the workpiece. The angular offset and the angular vertical rise of the tool seat in a standard lathe toolholder affect the cutting edge angle and the end clearance angle of a tool when it is set up for machining. The position of the point of the tool bit with respect to the axis of the workpiece, whether higher, lower, or on center, changes the amount of front clearance.

Figure 5-21 shows some of the standard toolholders used in lathe work. Notice the angles at which the tool bits sit in the various holders. You must consider these angles with respect to the angles ground in the tools and the angle that you set the toolholder with respect to the axis of the work. Also, notice that a right-hand toolholder is offset to the **LEFT** and a left-hand toolholder is offset to the **RIGHT**. For most machining operations, a right-hand toolholder uses a left-hand turning tool and a left-hand toolholder uses a right-hand turning tool. Study figures 5-20 and 5-21 carefully to help you understand this apparent contradiction. Also, take into consideration that if you use a quick change toolpost and toolholder (fig. 5-22), your end relief angle and your back rake angle will change.

The contour of a cutting tool is formed by the side cutting edge angle and the end cutting edge angle of the tool. Views A through G of fig. 5-20 show the

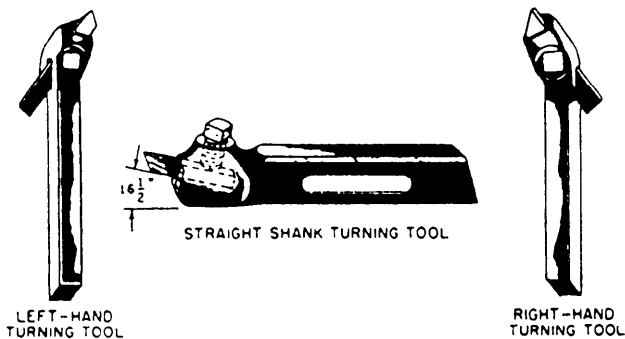
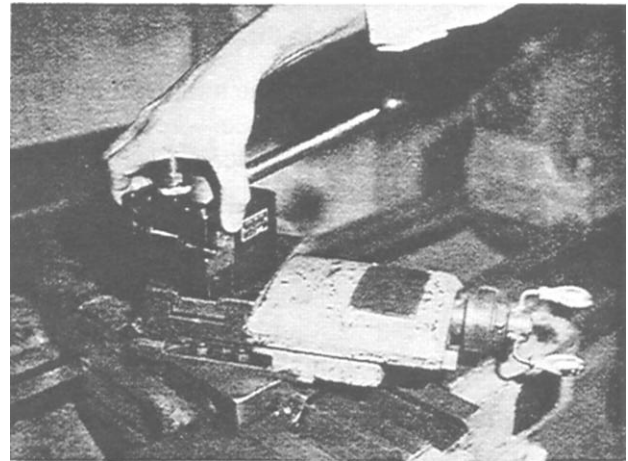


Figure 5-21.—Standard lathe toolholders.



28.302

Figure 5-22.—Quick change toolpost and toolholder.

recommended contours of several types of tools. There are no definite guidelines on either the form or the included angle of the contour of pointed tool bits, so you normally will form the contour as you prefer. For roughing cuts, the included angle of the contour of pointed bits generally should be made as large as possible and still provide clearance on the trailing side or end edge. Tools for threading, facing between centers, and parting have specific shapes because of the form of the machined cut or the setup used.

The basic steps are similar when you grind a single-edged tool bit for any machine. The difference is in shapes and angles. *Machinery's Handbook* shows the recommended angles under the section on single-point cutting tools. Use a coolant when you grind tool bits. Finish the cutting edge by honing it on an oilstone. Figure 5-23 shows the basic steps you

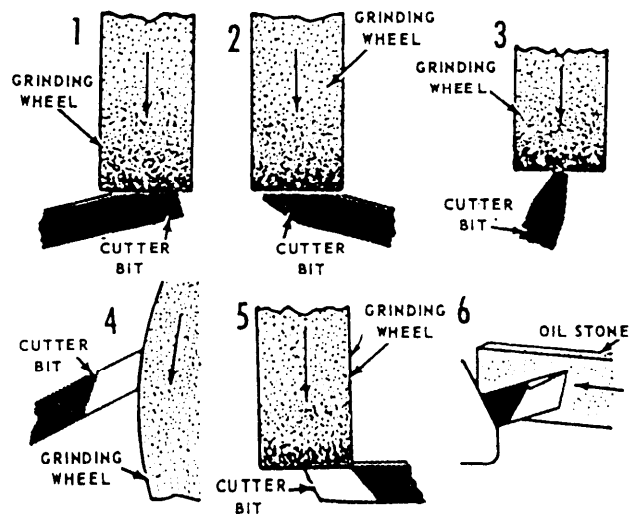


Figure 5-23.—Grinding and honing a lathe cutter bit.

should use to grind a round-nose turning tool. We'll describe each of the steps in the following paragraphs:

1. Grind the left side of the tool, holding it at the correct angle against the wheel to form the necessary side clearance. Use the coarse grinding wheel to remove most of the metal, then finish on the fine grinding wheel. (If you grind the cutting edge on the periphery of a wheel less than 6 inches in diameter, it will be undercut and will not have the correct angle.) Keep the tool cool while you grind it.
2. Grind the right side of the tool, holding it at the required angle to form the right side.
3. Grind the radius on the end of the tool. A small radius (approximately 1/32 inch) is preferable because a large radius may cause chatter. Hold the tool lightly against the wheel and turn it from side to side to produce the desired radius.
4. Grind the front of the tool to the desired front clearance angle.
5. Grind the top of the tool, holding it at the required angle to obtain the necessary side rake and back rake. Try not to remove too much of the metal. The more metal you leave on the tool, the better the tool will absorb the heat produced during cutting.
6. Hone the cutting edge all around and on top with an oilstone until you have a keen cutting edge. Use a few drops of oil on the oilstone. Honing will improve the cutting quality of the tool, produce a better finish on the work, and cause the cutting edge to stand up much longer than one that is not honed. The cutting edge should be sharp in order to shear off the metal rather than tear it off.

## SHAPER AND PLANER TOOLS

Shaper and planer cutting tools are similar in shape to lathe tools but differ mainly in their relief angles. These tools are held practically square with the work and do not feed during the cut; therefore, relief angles are much less than those in turning operations. The nomenclature of shaper and planer tools is the same as that for lathe tools; and the elements of the tool, such as relief and rake angles, are in the same relative positions as those shown in figure 5-18.

Several types of tools are required for shaper or planer operations. Although the types differ considerably in shape, the same general rules govern the grinding of each type.

To be sure you have an efficient cutting tool, grind the side relief and end relief of the tool to give a projecting cutting edge. If the clearance is insufficient, the tool bit will rub the work, causing excessive heat and producing a rough surface on the work. If the tool is given too much relief, the cutting edge will be weak and will tend to break during the cut. The front and side clearance angles should seldom exceed 3° to 5°.

In addition to relief angles, the tool bit must slope away from the cutting edge. This slope is known as side rake and reduces the power required to force the cutting edge into the work. The side rake angle is usually 10° or more, depending upon the type of tool and the metal being machined. Roughing tools should have no back rake although a small amount is generally required for finishing.

The shape and use of various standard shaper and planer cutting tools are illustrated in figure 5-24 and described in the following paragraphs:

- **Roughing tool:** This tool (fig. 5-24, view A) is very efficient for general use and is designed to take heavy cuts in cast iron or steel. You will generally grind it for left-hand operation as illustrated. For special applications, you can reverse the angles for right-hand cuts. Do not give this tool any back rake although the side rake may be as much as 20° for soft metals. Do finishing operations on small flat pieces with the roughing tool if a fine feed is used.

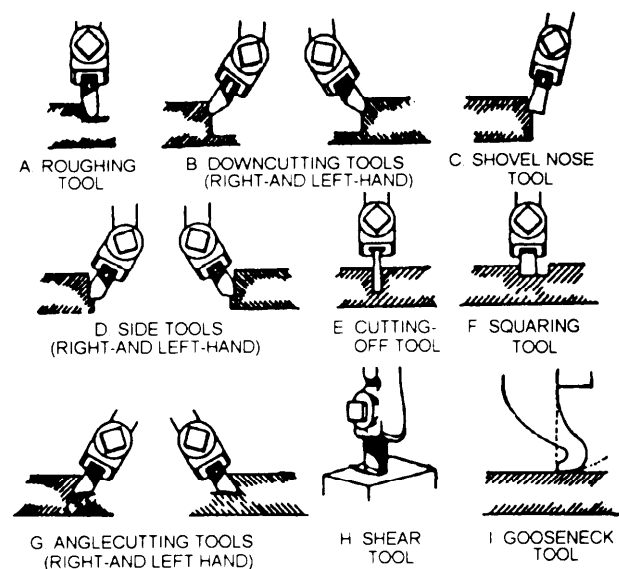


Figure 5-24.—Standard shaper and planer tools.

- **Downcutting tool:** You may grind and set this tool (fig. 5-24, view B) for either right- or left-hand operation and use it to make vertical cuts on edges, sides, and ends. It is substantially the same as the roughing tool, with the exception of its position in the toolholder.

- **Shovel-nose tool:** You may use this tool (fig. 5-24, view C) for downcutting in either a right- or left-hand direction. It requires a small amount of back rake and the cutting edge should be the widest part of the tool. Make the corners slightly rounded to give them longer life.

- **Side tool:** This tool (fig. 5-24, view D) comes in both right- and left-hand versions required to finish vertical cuts. You also may use these tools to cut or finish small horizontal shoulders to avoid changing tools after you make a vertical cut.

- **Cutting-off tool:** You should give this tool (fig. 5-24, view E) relief on both sides to allow free cutting action as the depth of cut is increased.

- **Squaring tool:** This tool (fig. 5-24, view F) is similar to a cutting-off tool and you can make it in any desired width. Use the squaring tool mostly to finish the bottoms and sides of shoulder cuts, keyways, and grooves.

- **Angle cutting tool:** This tool (fig. 5-24, view G) is adapted for finishing operations and is generally used following a roughing operation made with the downcutting tool. You may grind this tool for right- or left-hand operation.

- **Shear tool:** This tool (fig. 5-24, view H) is used to produce a high finish on steel and should be operated with a fine feed. Grind the cutting edge to form a radius of 3 to 4 inches, twisted to a 20° to 30° angle, and give it a back rake in the form of a small radius.

- **Gooseneck tool:** This tool (fig. 5-24, view I) is used to finish cast iron. You must forge it so the cutting edge is behind the backside of the tool shank. This feature allows the tool to spring away from the work slightly, reducing the tendency to gouge or chatter. Round off the cutting edge at the corners and give it a small amount of back rake.

## GRINDING HANDTOOLS

You should keep hand tools in the best usable condition. To do that, you must sharpen cutting edges frequently and true or shape certain other tools for special purposes. Shape or sharpen chisels, punches,

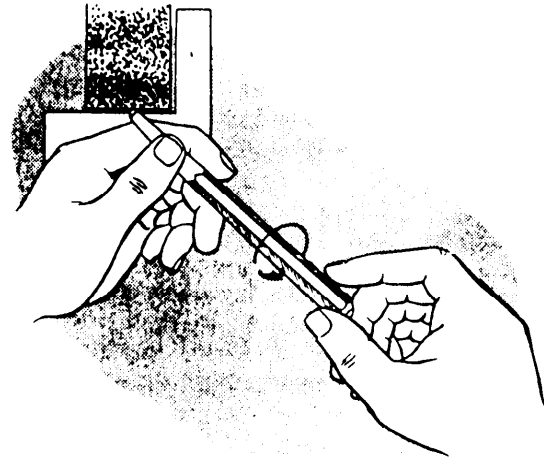


Figure 5-25.—Grinding a center punch with a bench grinder.

screwdrivers, and other handtools on an abrasive grinding wheel. We will explain the sharpening of these tools in the following paragraphs:

- **Center punches:** To sharpen a center punch, rest your hand on the tool rest of the grinder and cradle the end of the punch between the index finger and thumb of one hand, as shown in figure 5-25. Move the punch into light contact with the rotating grinder wheel, with the center line of the punch forming about a 45° angle with the face of the wheel. This will give the approximate 90° included angle required for a center punch. With the thumb and index finger of the other hand, rotate the punch as shown by the directional arrow in figure 5-25. Dip the punch in coolant frequently during the process.

- **Screwdriver tips:** Figure 5-26, views A and C, are the front views of a properly dressed common

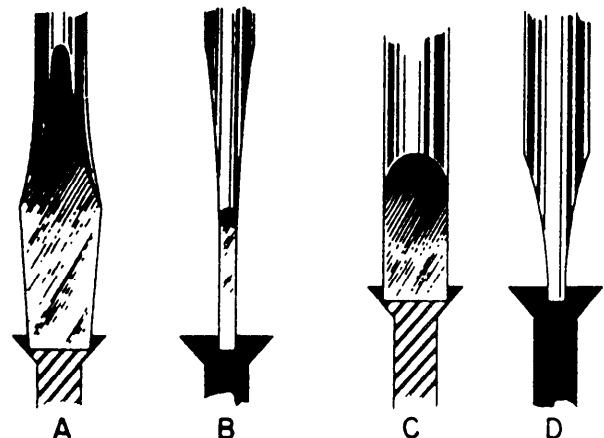


Figure 5-26.—Shapes of screwdrivers when properly dressed.

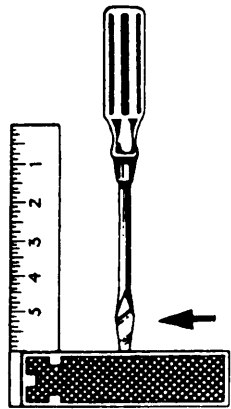


Figure 5-27.—Checking the squareness of the end of a screwdriver.

screwdriver. Views B and D are the side views. Dress the edges so the blade is symmetrical in shape, then square off the end. Check the squareness of the end by using a square. If the blade and shank appear to be parallel, the tip is square. See figure 5-27.

Next, grind the faces of the blade so they are parallel at the tip as shown in views B and D of figure 5-26. The thickness of the blade at the tip should be such that the tip will just enter the slot of the screw you intend to turn. With such a tip thickness, and the sides parallel, the screwdriver will have the least tendency to climb out of the screw slot when the screw is being turned. When grinding, do not let the tip get too hot or it will be softened.

- **Metal-cutting chisels:** These chisels are designed to cut cold metal, so we often use the general term *cold chisel* to describe them. The  $60^\circ$  angle shown in figure 5-28, is for a general-use cold chisel. Increase this angle to cut harder materials and decrease it for softer materials.

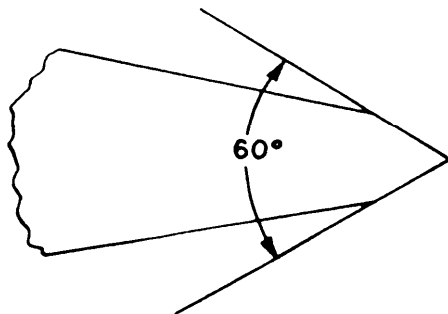


Figure 5-28.—Proper angle for a general use cold chisel.

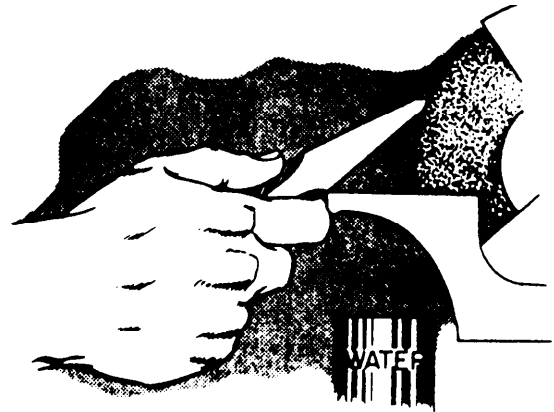


Figure 5-29.—Sharpening a cold chisel.

To sharpen this chisel, hold it to the wheel, resting it on the tool rest as shown in figure 5-29. Notice that the index finger, curved beneath the chisel, rides against the front edge of the tool rest. This ensures control of the chisel and will help you grind a single, equal bevel on each side.

Let the chisel rest lightly against the wheel while grinding. This will develop less heat and the air currents created by the wheel will have the maximum cooling effect. Be sure the cutting edge is kept cool or

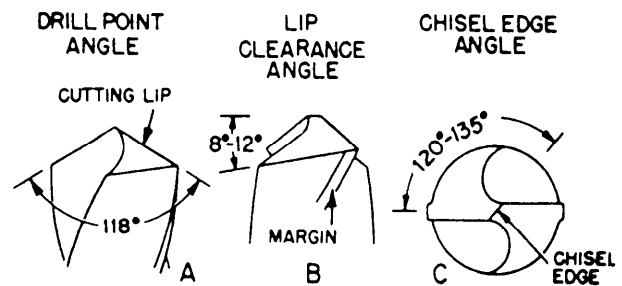


Figure 5-30.—Specifications for grinding a regular point twist drill.

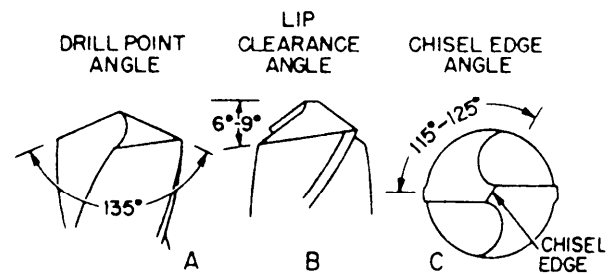
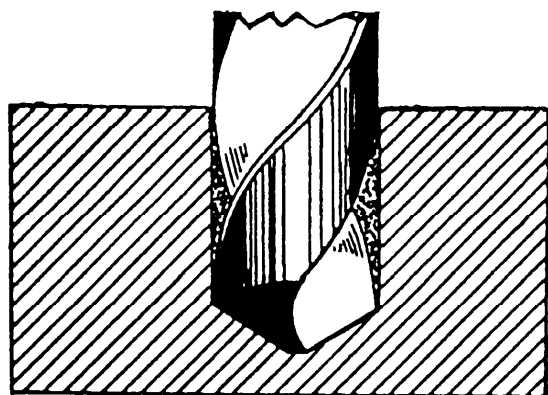
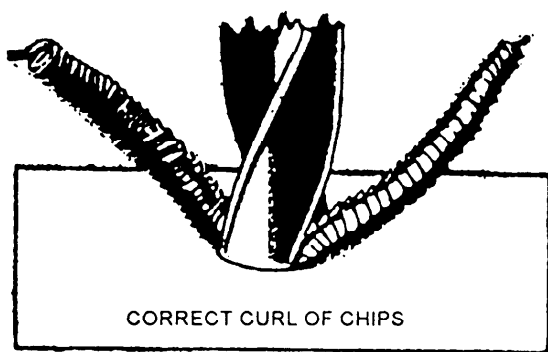
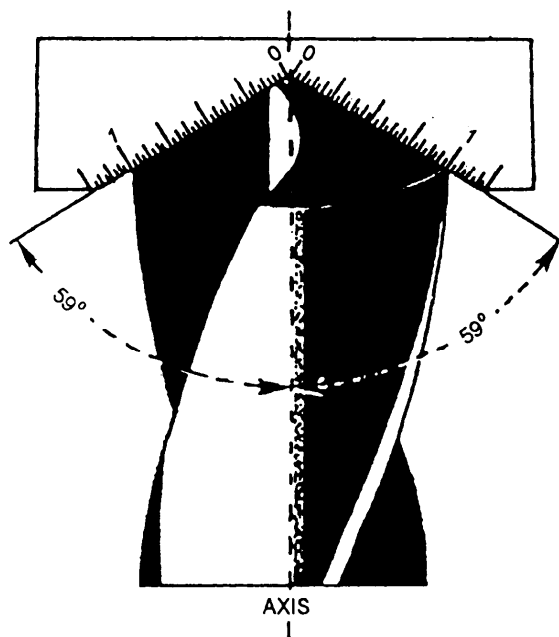


Figure 5-31.—Specifications for grinding a flat point twist drill.





RESULT OF CORRECT LIP GRINDING  
 Figure 5-32.—Grinding drill lip correctly.

it may be softened. You may also want to dip the chisel in a coolant.

### SHARPENING TWIST DRILLS

When grinding twist drills, it is most important that you meet the following criteria: (1) drill point

angles must be equal and correctly sized, (2) cutting lips must be of equal length, (3) the clearance behind the cutting lips must be correct, and (4) the chisel-edge angle must be correct. All four are equally important when grinding either a regular point (fig. 5-30) used for general purposes, or a flat point (fig. 5-31) used to drill hard and tough materials.

Figure 5-32 shows the results of correct lip grinding and how equal drill point angles and two equal length cutting lips help achieve correct drill results.

Figure 5-33 shows a drill being checked during grinding. The drill-point gauge is being held against the body of the drill and has been brought down to where the graduated edge of the gauge is in contact with one cutting edge. In this way, both the drill-point angle and the length of the cutting edge (or lip) are checked at the same time. The process is repeated for the other side of the drill.

You determine lip clearance behind the cutting lip at the margin by inspection. This means you look at the drill point and approximate the lip-clearance angle (see figs. 5-30, view B, and 5-31, view B), or compare it to the same angle that has been set on a protractor. The lip-clearance angle is not necessarily a definite angle, but it must be within certain limits. Notice that this angle ranges from 8° to 12° in figure 5-30, view B and from 6° to 9° in figure 5-31, view B. Whatever angle in the range is used, however, lip clearance should be the same for both cutting lips.

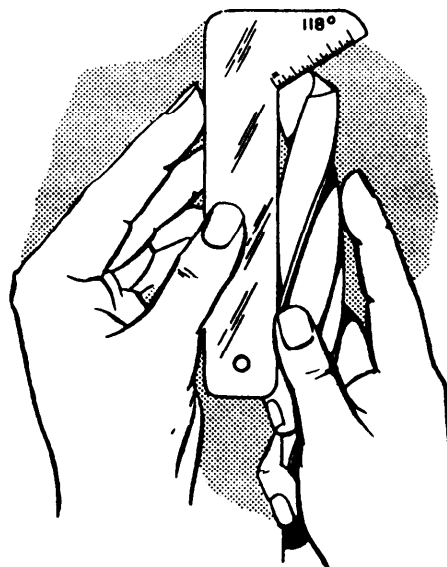


Figure 5-33.—Checking the drill point angle cutting edge.

There must be lip clearance behind the entire length of the cutting edge lip that extends from the margin of the drill to the chisel edge. This means that there must be “relief” behind the cutting lip along its entire length.

When you grind lip clearance, use the lip-clearance angle and the chisel-edge angle (shown in figs. 5-30, view C and 5-31, view C) as your guide to the amount of clearance you have ground into the drill behind the cutting lip along its entire length. The greater these angles are, the more clearance there will be behind their respective ends of the cutting lip. Too much lip clearance occurs when both the lip-clearance angle and the chisel-edge angle exceed their top limits. This weakens the cutting edge or lip by removing too much metal directly behind it. Too little or no lip clearance prevents the cutting edge from producing a chip, and the drill bit will not drill a hole.

To sharpen a twist drill, first ensure the grinder is ready. If necessary, dress the face of the wheel and adjust the toolrest. Start the grinder, let it come up to speed, and begin. Hold the twist drill as shown in figure 5-34, view A, which is a top view of the first step in grinding a drill. In the first step, be sure the axis of the drill makes an angle of about  $59^\circ$  (half of the drill-point angle) with the face of the wheel as shown in fig. 5-34, view A. Hold the cutting lip horizontal. Figure 5-35 is a side view of the same drill position shown in figure 5-34, view A.

The actual grinding of the drill point consists of three definite motions of the shank of the drill while you hold the point lightly against the rotating wheel. These three motions are (1) to the left, (2) clockwise rotation, and (3) downward.

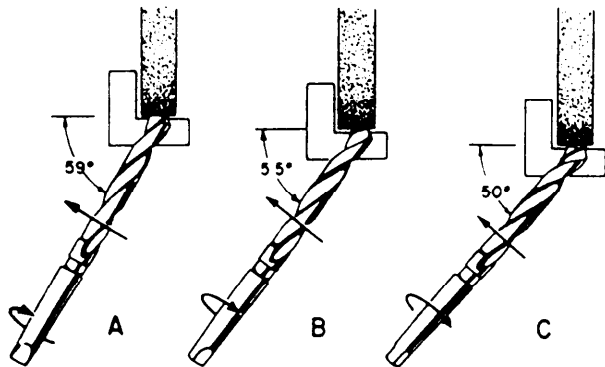


Figure 5-34.—Three steps for grinding a twist drill with a grinder.

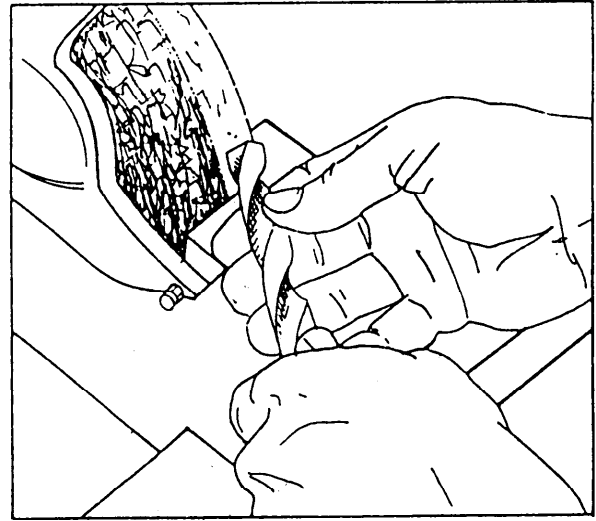


Figure 5-35.—Grinding a twist drill with a grinder (initial position).

Figure 5-34 shows the motion to the left in three views as the angle between the face of the wheel and the drill decreases from about  $59^\circ$  to about  $50^\circ$ .

In figure 5-34, the rotation arrows in views A, B, and C show the clockwise motion. The change in the position of the cutting lip and tang also shows rotation.

Because figure 5-34 is a top view, the downward motion is not noticeable. However all three motions are apparent when you compare the final position of the drill in figure 5-36 to the view in figure 5-35. All three motions taking place at the same time combine to produce the requirements mentioned earlier in this section: (1) equal and correctly sized drill-point angles, (2) equal-length cutting lengths, (3) correct clearance behind the cutting lips, and (4) correct

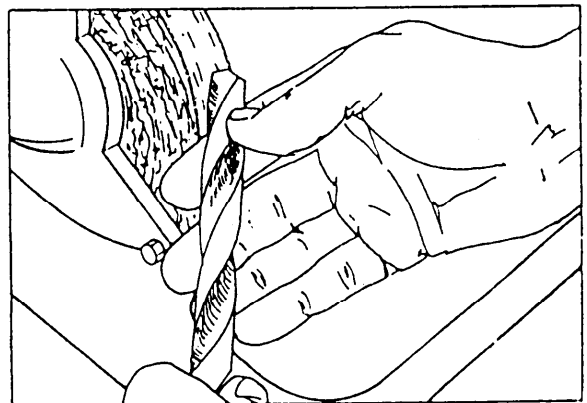


Figure 5-36.—Grinding a twist drill with a grinder (final position).

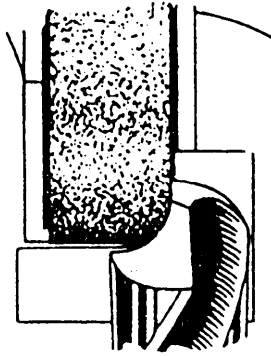


Figure 5-37.—Grinding a twist drill for brass.

chisel-edge angle. Use a drill-point gauge (fig. 5-33) and inspection to be sure you have met these four requirements.

### SHARPENING A TWIST DRILL TO DRILL BRASS

To sharpen a drill to drill brass, hold the cutting lip against the right side of the wheel as shown in figure 5-37. Grind the flute slightly flat, in line with the axis of the drill, to greatly reduce the included angle of the cutting lip. This will give the drill the scraping action needed for brass rather than the cutting action used for steel. It will prevent the tendency of the drill bit to be sucked into the hole being drilled. This can be especially troublesome when you drill through a pilot hole.

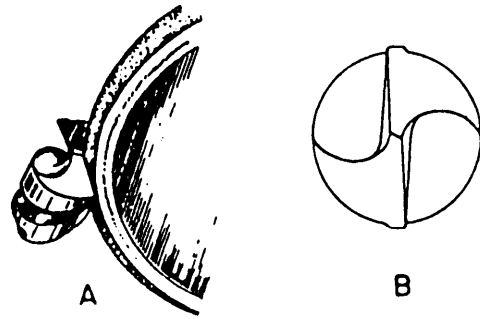


Figure 5-38.—Thinning the web of a twist drill.

### THINNING THE WEB OF A TWIST DRILL

Repeated sharpening shortens a drill and that increases the web thickness at the point. This may require web thinning.

To thin the web of a drill, hold the drill lightly to the face of a round-faced wheel, as shown in figure 5-38, view A, and thin the web for a short distance behind the cutting lip and into the flutes. This is shown in figure 5-38, view B. Notice that the cutting lip is actually (but only slightly) ground back, reducing its included angle a small amount but not enough to affect the operation of the drill.



## CHAPTER 6

# ENGINE LATHES

### CHAPTER LEARNING OBJECTIVES

*Upon completing this chapter, you should be able to do the following:*

- *Describe and explain the use of engine lathes.*
- *Explain engine lathe setup.*
- *Describe and explain engine lathe operations.*
- *Describe and explain methods of taper turning.*
- *Describe and explain cutting screw threads on an engine lathe.*

There are several types of lathes installed in shipboard machine shops, including the engine lathe, horizontal turret lathe, vertical turret lathe, and several variations of the basic engine lathe, such as bench and gap lathes. All lathes, except the vertical turret type, have one thing in common for all usual machining operations—the workpiece is held and rotated around a horizontal axis while being formed to size and shape by a cutting tool. In a vertical turret lathe, the workpiece is rotated around a vertical axis.

Horizontal lathes, as well as many of their attachments, and their operation are described in this chapter.

### ENGINE LATHE

An engine lathe similar to the one shown in figure 6-1 is found in every machine shop. It is used mainly for turning, boring, facing, and screw cutting, but it may also be used for drilling, reaming, knurling, grinding, spinning, and spring winding. The work held in an engine lathe can be rotated at any one of a number of different speeds. The cutting tool can be accurately controlled by hand or power for longitudinal feed and cross-feed. (Longitudinal feed is the movement of the cutting tool parallel to the axis of the lathe; cross-feed is the movement of the cutting tool perpendicular to the axis of the lathe.)

Lathe size is determined by various methods, depending upon the manufacturer. Generally, the size

is determined by two measurements: (1) either the diameter of work it will swing over the bed or the diameter of work it will swing over the cross-slide and (2) either the length of the bed or the maximum distance between centers. For example, a 14-inch by 6-foot lathe has a bed that is 6 feet long and will swing work (over the bed) up to 14 inches in diameter.

Engine lathes range in size from small bench lathes with a swing of 9 inches to very large lathes for turning work of large diameters, such as low-pressure turbine rotors. A 16-inch swing lathe is a good, average size for general purposes and is usually the size installed in ships that have only one lathe.

To learn the operation of a lathe, you must be familiar with the names and functions of the principal parts. In studying the principal parts in detail, remember that lathes all provide the same general functions even though the design may differ among manufacturers. As you read the description of each part, find its location on the lathe pictured in figure 6-1. For specific details on a given lathe, refer to the manufacturer's technical manual for that machine.

### BED AND WAYS

The bed is the base for the working parts of the lathe. The main feature of the bed is the ways, which are formed on its upper surface and run the full length of the bed. The tailstock and carriage slide on the

Deleted—No permission  
granted for electronic copy.

**Figure 6-1.—Gear-head engine lathe.**

ways in alignment with the headstock. The headstock is permanently bolted to the end at the operator's left.

Figure 6-2 shows the ways of a typical lathe. The inset shows the inverted V-shaped ways (1, 3, and 4)

and the flat way (2). The ways are accurately machined parallel to the axis of the spindle and to each other. The V-ways are guides that allow the carriage and tailstock to move over them only in their longitudinal direction. The flat way, number 2, takes

most of the downward thrust. The carriage slides on the outboard V-ways (1 and 4), which, because they are parallel to way number 3, keep the carriage aligned with the headstock and the tailstock at all times—an absolute necessity if accurate lathe work is to be done. Some lathe beds have two V-ways and two flat ways, while others have four V-ways.

For a lathe to perform satisfactorily, the ways must be kept in good condition. A common fault of careless machinists is to use the bed as an anvil for driving arbors or as a shelf for hammers, wrenches, and chucks. Never allow anything to strike a hard blow on the ways or damage their finished surfaces in any way. Keep them clean and free of chips. Wipe

them off daily with an oiled rag to help preserve their polished surface.

## HEADSTOCK

The headstock carries the headstock spindle and the mechanism for driving it. The headstock is similar to an automobile transmission except that it has more gear-shift combinations and therefore has a greater number of speed changes. On some lathes the gears are shifted hydraulically and others are manual. Our examples show the manual type of gear shifters. A speed index plate, attached to the headstock, shows the lever positions for the different spindle speeds.

Deleted—No permission  
granted for electronic copy.

Figure 6-2.—Rear view of lathe.

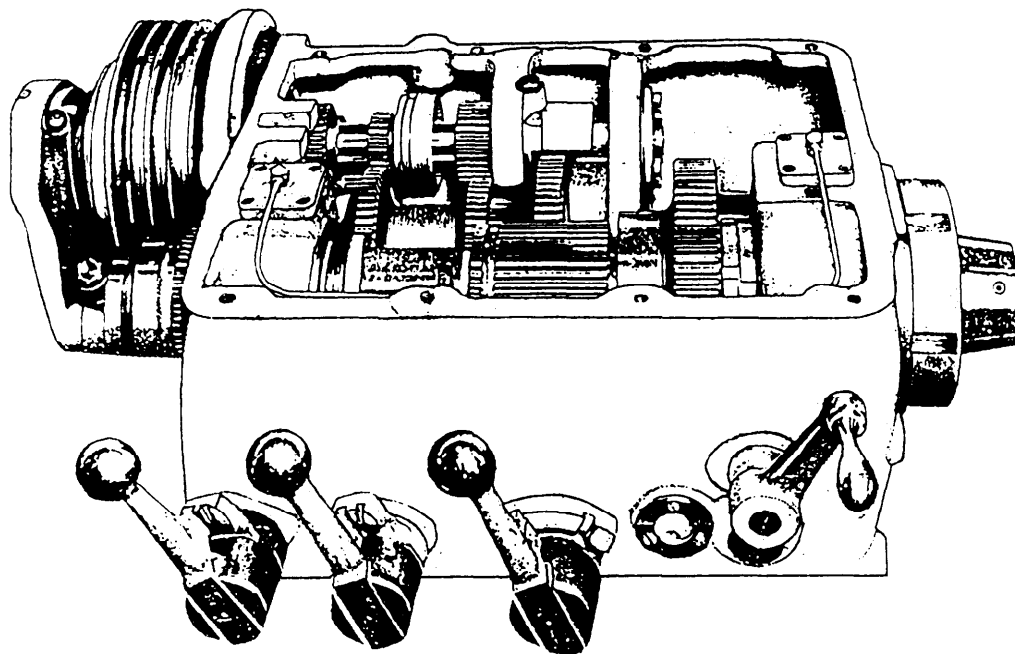


Figure 6-3.—Sliding gear-type headstock

Figure 6-4 shows this plate for the geared headstock in figure 6-3. Always stop the lathe when you shift gears to avoid damaging the gear teeth.

Figure 6-3 shows the interior of a typical geared headstock that has 16 different spindle speeds. The driving pulley at the left is driven at a constant speed by a motor located under the headstock. Various combinations of gears in the headstock transmit the power from the drive shaft to the spindle through an intermediate shaft. Use the speed-change levers to shift the sliding gears on the drive and intermediate shafts to line up the gears in different combinations. This produces the gear ratios you need to obtain the various spindle speeds. Note that the back gear lever has high and low speed positions for each combination of the other gears (fig. 6-4).

SLIDING GEAR HEAD		POSITION LEVER HEADSTOCK	BACK GEAR LEVER
(XXX) DRIVING PULLEY 500 RPM SERIAL No. _____ CONTRACT No. _____ DATE OF MANUFACTURE _____ INSPECTION _____			16 98
			19 121
			26 152
			32 188
			42 246
			52 306
			65 385
			81 476

Figure 6-4.—Speed index plate.

The headstock casing is filled with oil to lubricate the gears and the shifting mechanism it contains. Parts not immersed in the oil are lubricated by either the splash produced by the revolving gears or by an oil pump. Be sure to keep the oil to the oil level indicated on the oil gauge.

The headstock spindle (fig. 6-5) is the main rotating element of the lathe and is directly connected to the work, which revolves with it. The spindle is supported in bearings at each end of the headstock through which it projects. The section of the spindle between the bearings carries the pulleys or gears that

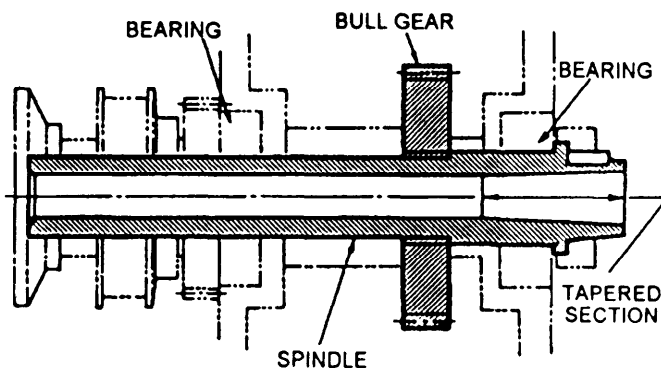


Figure 6-5.—Cross section of a headstock spindle.



turn the spindle. The nose of the spindle holds the driving plate, the faceplate, or a chuck. The spindle is hollow throughout its length so that bars or rods can be passed through it from the left and held in a chuck at the nose. The chuck end of the spindle is bored to a Morse taper to receive the live center. The hollow spindle also permits the use of the draw-in collet chuck, which is discussed later in this chapter. At the other end of the spindle is the gear by which the spindle drives the feed and screw-cutting mechanism through a gear train located on the left end of the lathe.

## TAILSTOCK

The tailstock (fig. 6-6) may be used to hold the dead or ball bearing center or it can be used to hold tapered shank drills, reamers, and drill chucks. The tailstock moves on the ways along the length of the bed to accommodate work of varying lengths. It can

be clamped in the desired position by the tailstock clamping nut (13).

The dead center (11) is held in a tapered hole (bored to a Morse taper) in the tailstock spindle (6). To move the spindle back and forth in the tailstock barrel for longitudinal adjustment, turn the handwheel (9) that turns the spindle-adjusting screw (7) in a tapped hole in the spindle at (8). The spindle is kept from revolving by a key (4) that fits a spline, or keyway (5), cut along the bottom of the spindle as shown. After making the final adjustment, use the binding clamp (10) to lock the spindle in place.

The tailstock body is made in two parts. The bottom, or base (1), is fitted to the ways; the top (2) can move laterally on its base. The lateral movement can be closely adjusted by setscrews. Zero marks inscribed on the base and top indicate the center position and provide a way to measure setover for taper turning. Setover of the tailstock for taper turning is described in a later chapter.

Deleted—No permission  
granted for electronic copy.

Figure 6-6.—Cross section of a tailstock.

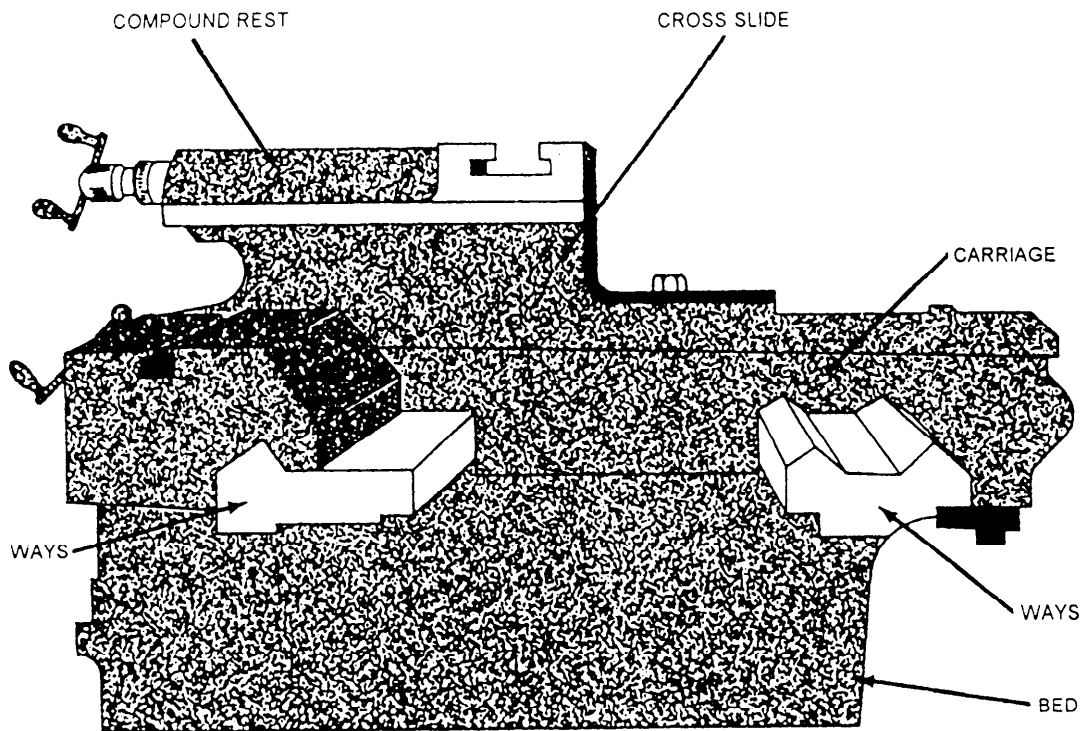


Figure 6-7.—Side view of a carriage mounted on the bed.

Before you insert a center or tooling into the spindle, carefully clean the tapered shank and wipe out the tapered hole of the spindle. After you put a drill or a reamer into the tapered hole of the spindle, be sure to tighten it in the spindle so that the tool will not revolve. If the drill or reamer is allowed to revolve, it will score the tapered hole and destroy its accuracy. The spindle of the tailstock is engraved with graduations that help in determining the depth of a cut when you drill or ream.

## CARRIAGE

The carriage carries the cross-feed slide and the compound rest that, in turn, carries the cutting tool in the toolpost. The carriage slides on the ways along the bed (fig. 6-7).

Figure 6-8 shows a top view of the carriage. The wings of the H-shaped saddle contain the bearing surfaces, which are fitted to the V-ways of the bed. The crosspiece is machined to form a dovetail for the cross-feed slide. The cross-feed slide is closely fitted to the dovetail and has a tapered gib that fits between the carriage dovetail and the matching dovetail of the cross-feed slide. The gib permits small adjustments to remove any looseness between the two parts. The

Deleted—No permission granted for electronic copy.

Figure 6-8.—Carriage (top view).

slide is securely bolted to the cross-feed nut that moves back and forth when the cross-feed screw is turned by the handle. The micrometer dial on the cross-feed handle is graduated to permit accurate infeed. Depending on the manufacturer of the lathe, the dial may be graduated so that each division represents a 1 to 1 or a 2 to 1 ratio. The compound rest is mounted on top of the cross-feed slide.

The carriage has T-slots or tapped holes for clamping work for boring or milling. When the lathe is used in this manner, the carriage movement feeds the work to the cutting tool, which is revolved by the headstock spindle.

You can lock the carriage in any position on the bed by tightening the carriage clamp screw. Use the clamp screw only when doing such work as facing or cutting-off, for which longitudinal feed is not required. Normally, keep the carriage clamp in the released position. Always move the carriage by hand to be sure it is free before you apply the automatic feed.

## APRON

The apron is attached to the front of the carriage. It contains the mechanism that controls the movement of the carriage for longitudinal feed and thread cutting and controls the lateral movement of the cross-slide. You should thoroughly understand the construction and operation of the apron before you attempt to operate the lathe.

In general, a lathe apron contains the following mechanical parts:

- A longitudinal feed handwheel for moving the carriage by hand along the bed. This handwheel turns a pinion that meshes with a rack gear secured to the lathe bed.
- Gear trains driven by the feed rod. These gear trains transmit power from the feed rod to move the carriage along the ways and to move the cross-slide across the ways, thus providing powered longitudinal feed and cross-feed.
- Friction clutches operated by knobs on the apron to engage or disengage the power-feed mechanism. (Some lathes have a separate clutch for longitudinal feed and cross-feed; others have a single clutch for both.) (**NOTE:** The power feeds are usually driven through a friction clutch to prevent damage to the gears if excessive strain is put on the feed mechanism. If clutches are not provided, there is some form of safety device that operates to disconnect the feed rod from its driving mechanism.)

- A selective feed lever or knob for engaging the longitudinal feed or cross-feed as desired.
- Half-nuts that engage and disengage the lead screw when the lathe is used to cut threads. They are opened or closed by a lever located on the right side of the apron. The half-nuts fit the thread of the lead screw, which turns in them like a bolt in a nut when they are clamped over it. The carriage is then moved by the thread of the lead screw instead of by the gears of the apron feed mechanisms. (The half-nuts are engaged only when the lathe is used to cut threads, at which time the feed mechanism must be disengaged. An interlocking device that prevents the half-nuts and the feed mechanism from engaging at the same time is usually provided as a safety feature.)

Aprons on lathes made by different manufacturers differ somewhat in construction and in the location of controlling levers and knobs. But, they all are designed to perform the same functions. The principal difference is in the arrangement of the gear trains for driving the automatic feeds. For example, in some aprons there are two separate gear trains with separate operating levers for longitudinal feed and cross feed. In others, both feeds are driven from the same driving gear on the feed rod through a common clutch, with one feed at a time connected to the drive by a selector lever. The apron shown in figure 6-9 is of the latter type.

Deleted—No permission  
granted for electronic copy.

Figure 6-9.—Rear view of a lathe apron.

Deleted—No permission  
granted for electronic copy.

Figure 6-10.—Quick-change gear box (rear view).

## FEED ROD

The feed rod transmits power to the apron to drive the longitudinal feed and cross feed mechanisms. The feed rod is driven by the spindle through a train of gears, and the ratio of its speed to that of the spindle can be varied by changing gears to produce various rates of feed. The rotating feed rod drives gears in the apron. These gears in turn drive the longitudinal feed and cross-feed mechanisms through friction clutches, as explained in the description of the apron.

Lathes that do not have a separate feed rod have a spline in the lead screw to serve the same purpose. The apron shown in figure 6-9 belongs to a lathe of this type and shows clearly how the worm that drives the feed mechanism is driven by the spline in the lead screw. If a separate feed rod were used, it would drive the feed worm in the same manner, that is, by means of a spline. The spline permits the worm, which is keyed to it, to slide freely along its length to conform with the movement of the carriage apron.

## LEAD SCREW

The lead screw is used for thread cutting. Along its length are accurately cut Acme threads that engage the

threads of the half-nuts in the apron when half-nuts are clamped over it. When the lead screw turns in the closed half-nuts, the carriage moves along the ways a distance equal to the lead of the thread in each revolution of the lead screw. Since the lead screw is connected to the spindle through a gear train (discussed later in the section on quick-change gear mechanism), the lead screw rotates with the spindle. Therefore, whenever the half-nuts are engaged, the longitudinal movement of the carriage is directly controlled by the spindle rotation. The cutting tool is moved a definite distance along the work for each revolution that the spindle makes.

The ratio of the threads per inch of the thread being cut and the thread of the lead screw is the same as the ratio of the speeds of the spindle and the lead screw. For example: If the lead screw and spindle turn at the same speed, the number of threads per inch being cut is the same as the number of threads per inch of the lead screw. If the spindle turns twice as fast as the lead screw, the number of threads being cut is twice the number of threads per inch of the lead screw.

You can cut any number of threads by merely changing gears in the connecting gear train to get the desired ratio of spindle and lead screw speeds.

Deleted—No permission  
granted for electronic copy.

Figure 6-11.—Quick-change gear box.

## QUICK-CHANGE GEAR MECHANISM

To do away with the inconvenience and loss of time involved in removing and replacing change gears, most modern lathes have a self-contained change gear mechanism, commonly called the quick-change gear box. There are a number of types used on different lathes but they are all similar in principle.

The mechanism consists of a cone-shaped group of change gears. You can instantly connect any single gear to the gear train by moving a sliding tumbler gear controlled by a lever. The cone of gears is keyed to a shaft that drives the lead screw (or feed rod) directly or through an intermediate shaft. Each gear in the cluster has a different number of teeth and hence produces a different gear ratio when connected in the train. The same thing happens as when the screw gear in the gear train is changed, described previously. Sliding gears also produce other changes in the gear train to increase the number of different ratios you can get with the cone of change gears just described. All changes are made by

shifting appropriate levers or knobs. An index plate or chart mounted on the gear box indicates the position for placing the levers to get the necessary gear ratio to cut the thread or produce the feed desired.

Figure 6-10 is the rear view of one type of gear box, showing the arrangement of gears. Splined shaft F turns with gear G, which is driven by the spindle through the main gear train on the end of the lathe. Shaft F in turn drives shaft H through tumbler gear T, which can be engaged with any one of the cluster of eight different size gears on shaft H by means of lever C. Shaft H drives shaft J through a double clutch gear, which takes the drive through one of three gears, depending on the position of lever B (right, center, or left). Shaft J drives the lead screw through gear L.

Either the lead screw or the feed rod can be connected to the final drive shaft of the gear box by engaging appropriate gears.

Twenty-four different gear ratios are provided by the quick-change gear box shown in figure 6-11. The

lower lever has eight positions, each of which places a different gear in the gear train and hence produces eight different gear ratios. The three positions of the upper level produce three different gear ratios for each of the 8 changes obtained with the lower lever, thus making 24 combinations in the box alone. You can double this range by using a sliding compound gear that provides a high- and low-gear ratio in the main gear train. This gives two ratios for every combination obtainable in the box, or 48 combinations in all.

The index chart on the gear box also shows the various rates of power longitudinal feed per spindle revolution that you can get by using the feed mechanism of the apron. For example, in figure 6-11, note that the finest longitudinal feed is 0.0030 inch per revolution of spindle, the next finest is 0.0032 inch, and so on. To arrange the gear box for power longitudinal feed, select the feed you wish to use and follow the same procedure explained for cutting screw threads, except that you engage the power feed lever instead of the half-nuts. Cross-feeds are not listed on the chart but you can determine them by

multiplying the longitudinal feeds by 0.375, as noted on the index plate.

On a lathe with a separate feed rod, a feed-thread shifting lever located at the gear box connects the drive to the feed rod or the lead screw as desired. When the feed rod is engaged, the lead screw is disengaged and vice versa.

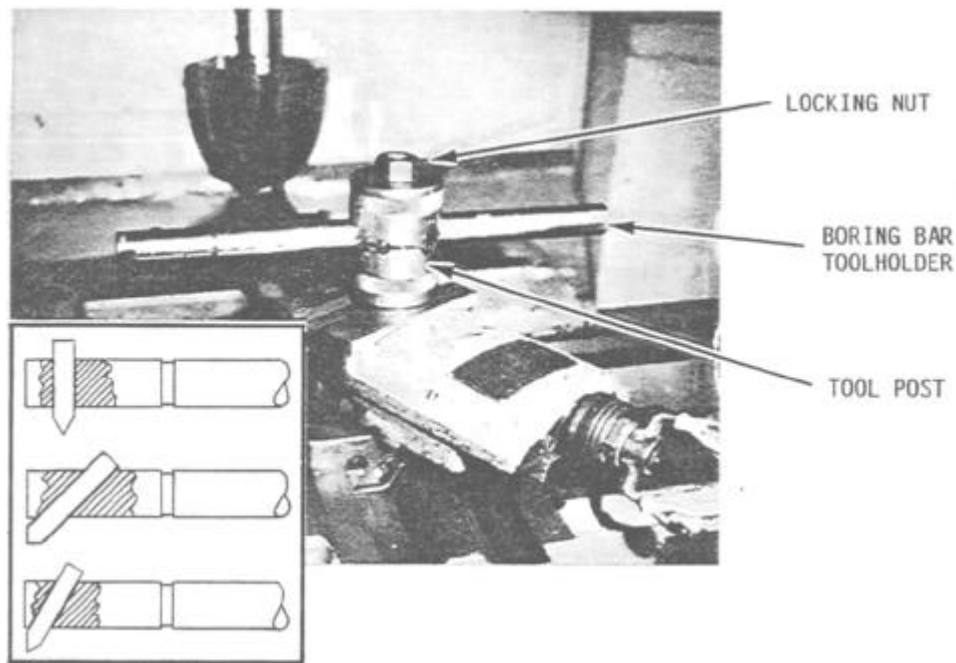
You can cut metric threads on some lathes that have an English lead screw (threads per inch machined on it) by transposing a set of gears in the lead screw to the spindle gear train that provides the correct conversion ratio. You can find information on this in handbooks for machinists, in the equipment technical manual, and through direct correspondence with the equipment manufacturer.

### **COMPOUND REST**

The compound rest provides a rigid, adjustable mounting for the cutting tool. The compound rest assembly has the following principal parts (fig. 6-12):

Deleted—No permission  
granted for electronic copy.

**Figure 6-12.-Compound rest.**



28.299

Figure 6-13.—Castle-type toolpost and toolholder.

- The compound rest swivel (2), which can be swung around to any desired angle and clamped in position. It is graduated over an arc of 90° on each side of its center position for ease in setting to the angle you select. This feature is used in machining short, steep tapers such as the angle on bevel gears, valve disks, and lathe centers.
- The compound rest top, or topslide (3), is mounted as shown on the swivel section (2) on a dovetailed slide. It is moved along the slide by the compound rest feed screw turning in the nut (4), operated by the handle (5), in a manner similar to the cross feed described previously (fig. 6-8). This provides for feeding at any angle (determined by the angular setting of the swivel section), while the cross-slide feed provides only for feeding at a right angle to the axis of the lathe. The graduated collar on the compound rest feed screw reads in thousandths of an inch for fine adjustment in regulating the depth of cut.

### ATTACHMENTS AND ACCESSORIES

Accessories are the tools and equipment used in routine lathe machining operations. Attachments are

special fixtures that may be secured to the lathe to extend the versatility of the lathe to include taper-cutting, milling, and grinding. Some of the common accessories and attachments used on lathes are described in the following paragraphs.

### TOOLPOSTS

Three popular types—standard, castle, and quick change—are discussed in the following paragraphs. The sole purpose of the toolpost is to provide a rigid support for the toolholder.

The standard toolpost is mounted in the T-slot of the compound rest top as shown in figure 6-12. A toolholder (13) is inserted in the slot in the toolpost and rests on the toolpost wedge (11) and the toolpost ring (12). By tightening the setscrew (10), you clamp the whole unit firmly in place with the tool in the desired position.

The castle-type toolpost (fig. 6-13) is used with boring bar-type toolholders. It mounts in the T-slot and the toolholder (boring bar) passes through it and the holddown bolt. By tightening the locking nut, you clamp the entire unit firmly in place. Various size holes through the toolpost allow the use of assorted diameter boring bars.

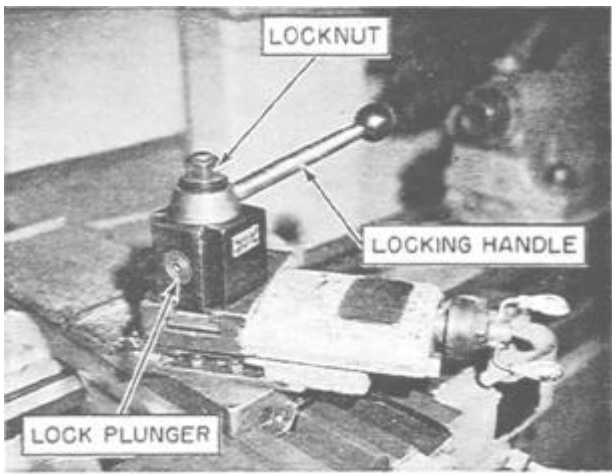


Figure 6-14.—Quick-change toolpost.

28.300

The quick-change toolpost (fig. 6-14) is available in most Navy machine shops. It mounts in the T-slots and is tightened in place by the locknut, which clamps the toolpost firmly in place. Special-type toolholders are used in conjunction with this type of toolpost and are held in place by a locking plunger, which is operated by the toolholder locking handle. Some toolposts have a sliding gib to lock the toolholder. With this type of toolpost, only the toolholders are changed, allowing the toolpost to remain firmly in place.

### TOOLHOLDERS

Lathe toolholders are designed to be used with the various types of toolposts. Only the three most

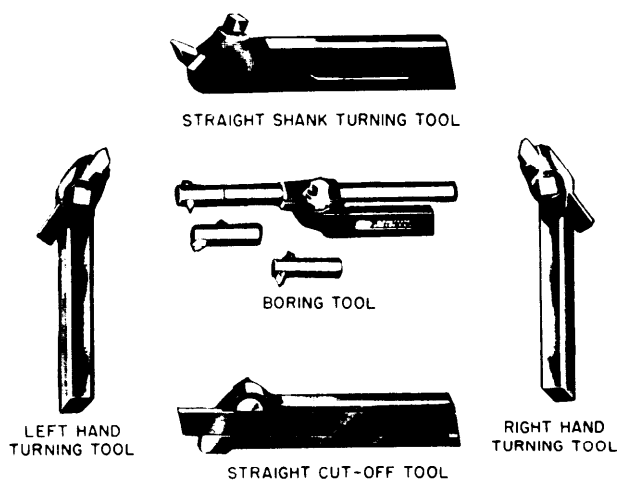
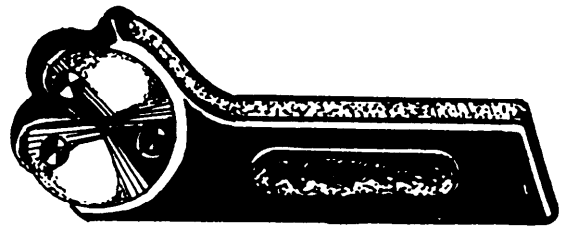


Figure 6-15.—Standard lathe toolholders.

28.67



KNURLING TOOL

Figure 6-16.—Knurling tool.

commonly used types—standard, boring bar, and quick change—are discussed in this chapter. The toolholder holds the cutting tool (tool bit) in a rigid and stable position. Toolholders are generally made of a softer material than the cutting tool. They are large in size and help to carry the heat generated by the cutting action away from the point of the cutting tool.

Standard toolholders were discussed briefly in chapter 5 of this manual. However, there are more types (figs. 6-15 and 6-16) than those discussed in chapter 5.

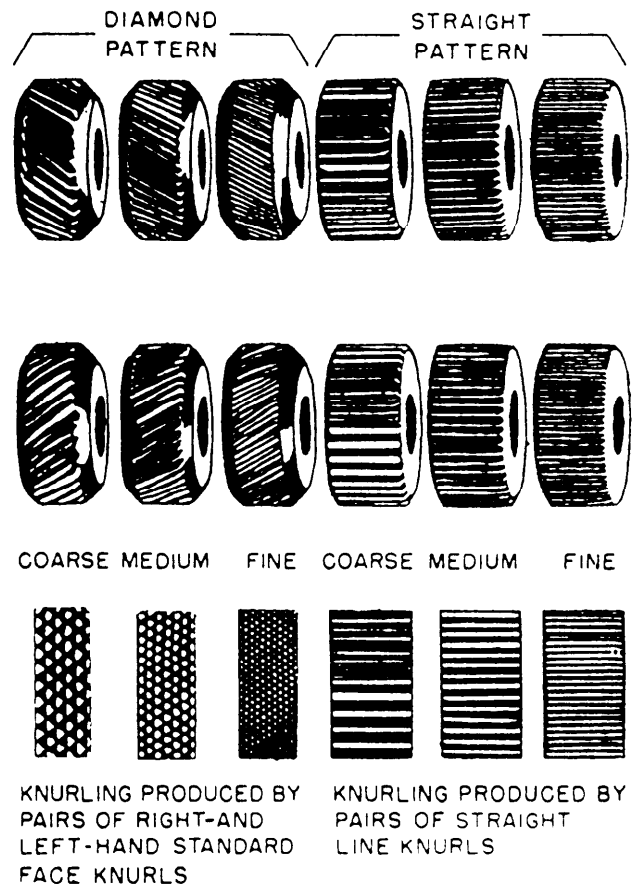


Figure 6-17.—Types of knurling rollers.



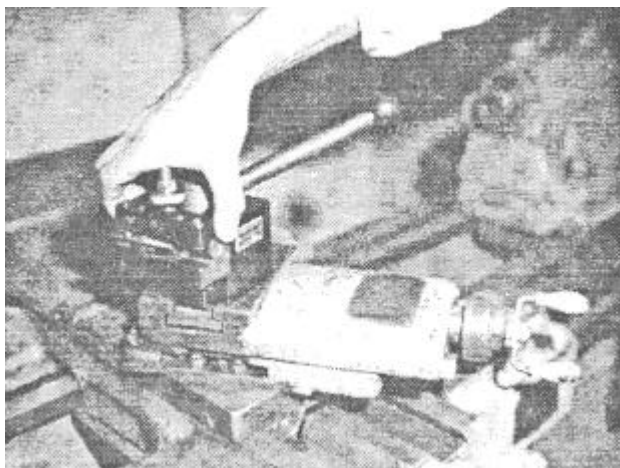
A knurling tool (fig. 6-16) forms a pattern on the work by being fed into the work as it revolves. The purpose of knurling is to give a roughened surface on round metal parts, like knobs, to give a better grip for handling. The knurled roller comes in a wide variety of patterns. (See fig. 6-17.)

The boring bar toolholder is nothing more than a piece of round stock with a screw-on cap (fig. 6-13). The caps are available with square holes broached through them at various angles and sizes. When the proper size tool bit is inserted into the cap and the cap is screwed on to the threaded end of the piece of round stock, the entire unit becomes a very rigid boring tool, which is used with the castle-type toolpost.

The quick-change toolholder, which is the most widely used toolholder (fig. 6-18), is mounted on the toolpost by sliding it from above and downward over the dovetails. This toolholder has a height adjusting ring to allow you to set the proper height before locking it in place. The quick-change toolholder comes in a wide range of styles. A few of these styles are shown in figure 6-19.

## LATHE CHUCKS

The lathe chuck is a device for holding lathe work. It is mounted on the nose of the spindle. The work is held by jaws that can be moved in radial slots toward the center to clamp down on the sides of the work. These jaws are moved in and out by screws turned by a chuck wrench applied to the sockets located at the outer ends of the slots.



28.302

Figure 6-18.—Quick-change toolpost and toolholder.

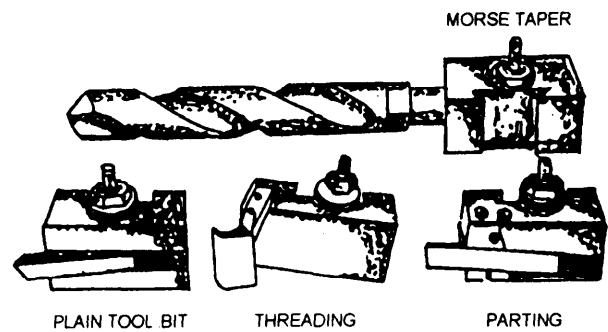
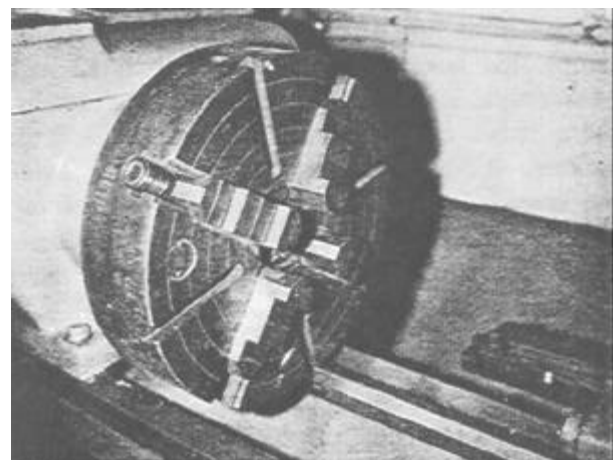


Figure 6-19.—Quick-change toolholder.

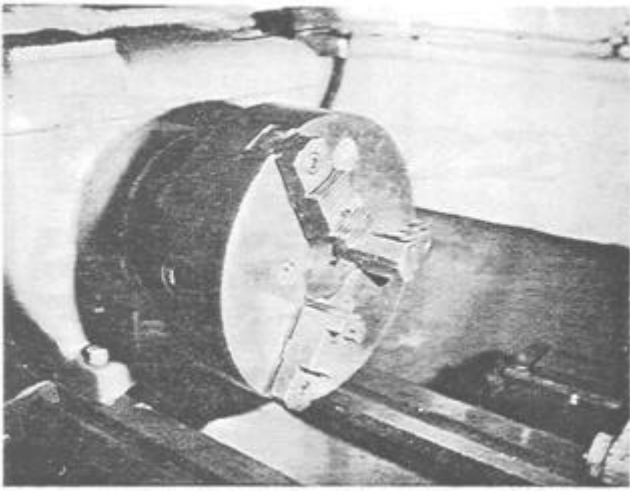
The four-jaw independent lathe chuck, figure 6-20, is the most practical for general work. The four jaws are adjusted one at a time, making it possible to hold work of various shapes and to adjust the center of the work to coincide with the axial center of the spindle.

There are several different styles of jaws for four-jaw chucks. You can remove some of the chuck jaws by turning the adjusting screw and then re-inserting them in the opposite direction. Some chucks have two sets of jaws, one set being the reverse of the other. Another style has jaws that are bolted onto a slide by two socket-head bolts. On this style you can reverse the jaws by removing the bolts, reversing the jaws, and re-inserting the bolts. You can make special jaws for this style chuck in the shop and machine them to fit a particular size outside or inside diameter.



28.304

Figure 6-20.—Four-jaw independent chuck.



28.305

Figure 6-21.—Three-jaw universal chuck.

The three-jaw universal or scroll chuck (fig. 6-21) can be used only for holding round or hexagonal work. All three jaws move in and out together in one operation. They move simultaneously to bring the work on center automatically. This chuck is easier to operate than the four-jaw type, but when its parts become worn you cannot rely on its accuracy in centering. Proper lubrication and constant care in use are necessary to ensure reliability. The same styles of jaws available for the four-jaw chuck are also available for the three-jaw chuck.

Combination chucks are universal chucks that have independent movement of each jaw in addition to the universal movement.

Figure 6-3 shows the usual means provided for attaching chucks and faceplates to a lathe. The tapered nose spindle (fig. 6-3) is usually found on lathes that have a swing greater than 12 inches. Matching internal tapers and keyways in chucks for these lathes ensure accurate alignment and radial locking. A free-turning, internally threaded collar on the spindle screws onto a boss on the back of the chuck to secure the chuck to the spindle nose. On small lathes, chucks are screwed directly onto the threaded spindle nose.

The draw-in collet chuck is used to hold small work for machining. It is the most accurate type of chuck and is intended for precision work.

Figure 6-22 shows the five parts of the collet chuck assembled in place in the lathe spindle. The collet, which holds the work, is a split cylinder with an outside taper that fits into the tapered closing

sleeve and screws into the threaded end of the hollow drawbar that passes through the hollow spindle. When the handwheel, which is attached by threads to the outside of the drawbar, is turned clockwise, the drawbar pulls the collet into the tapered sleeve, thereby decreasing the diameter of the hole in the collet. As the collet is closed around the work, the work is centered accurately and is held firmly by the chuck.

Collets are made with hole sizes ranging from 1/64 inch up, in MS-inch steps. The best results are obtained when the diameter of the work is exactly the same size as the dimension stamped on the collet.

To ensure accuracy of the work when using the draw-in collet chuck, be sure that the contact surfaces of the collet and the closing sleeve are free of chips and dirt. (**NOTE:** The standard collet has a round hole, but special collets for square and hexagonal shapes are available.)

The rubber collet chuck (fig. 6-23) is designed to hold any bar stock from 1/16 inch up to 1 3/8 inch. It is different from the draw-in type of collet previously mentioned in that the bar stock does not have to be exact in size.

The rubber flex collet consists of rubber and hardened steel plates. The nose of the chuck has external threads, and, by rotating the handwheel (fig. 6-23), you compress the collet around the bar. This exerts equal pressure from all sides and enables you to align the stock very accurately. The locking ring, when pressed in, gives a safe lock that prevents the collet from coming loose when the machine is in operation.

Deleted—No permission granted for electronic copy.

Figure 6-22.—Draw-in collet chuck assembled.

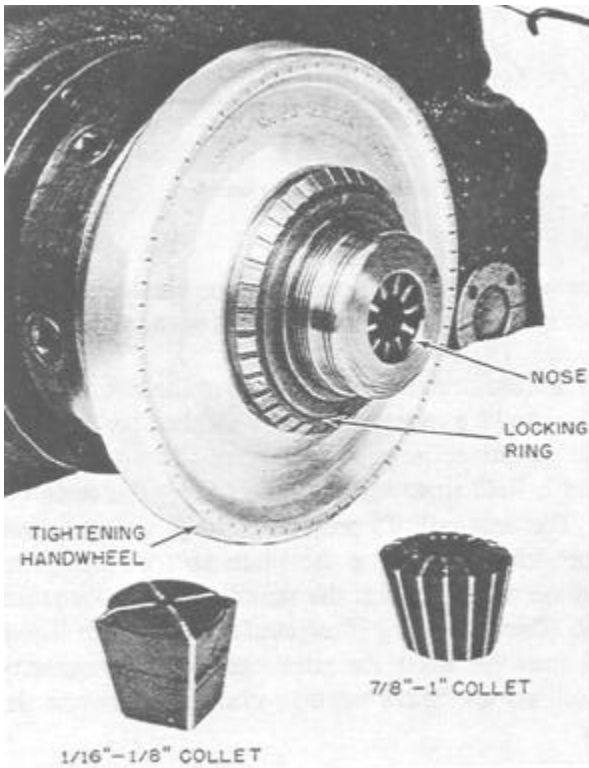


Figure 6-23.—Rubber flex collet chuck.

28.306

Drill chucks are used to hold center drills, straight shank drills, reamers, taps, and small rods. The drill chuck is mounted on a tapered shank or arbor that fits the Morse taper hole in either the headstock or tailstock spindle. Figure 6-24 shows the three-jaw type. A revolving sleeve operated by a key opens or closes the three jaws simultaneously to clamp and center the drill in the chuck.

Faceplates are used for holding work that cannot be swung on centers or in a chuck because of its shape or dimensions. The T-slots and other openings on the surface of the faceplate provide convenient anchor points for bolts and clamps used to secure the work to the faceplate. The faceplate is mounted on the nose of the spindle.

The driving plate is similar to a small faceplate and is used primarily for driving work that is held between centers. A radial slot receives the bent tail of a lathe dog clamped to the work to transmit rotary motion to the work.

Deleted—No permission granted for electronic copy.

Figure 6-24.—Drill chuck.

## LATHE CENTERS

The lathe centers shown in figure 6-25 provide a means for holding the work between points so it can be turned accurately on its axis. The headstock spindle center is called the **LIVE** center because it revolves with the work. The tailstock center is called the **DEAD** center because it does not turn. Both live and dead centers have shanks turned to a Morse taper to fit the tapered holes in the spindles; both have points finished to an angle of 60°. They differ only in that the dead center is hardened and tempered to resist the wearing effect of the work revolving on it. The live center revolves with the work and is usually left soft. The dead center and live center must **NEVER**

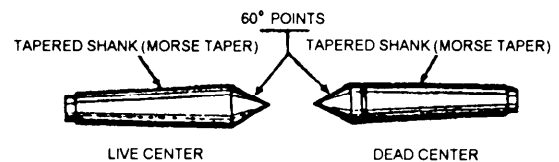


Figure 6-25.—Lathe centers.

28.93

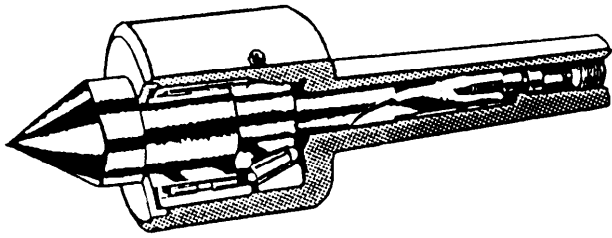


Figure 6-26.—Cutaway showing the construction of a ball bearing center.

be interchanged. A dead center requires a lubricant between it and the center hole to prevent seizing and burning of the center. (NOTE: There is a groove around the hardened tail center to distinguish it from the live center.)

The centers fit snugly in the tapered holes of the headstock and tailstock spindles. If chips, dirt, or burrs prevent a perfect fit in the spindles, the centers will not run true.

To remove the headstock center, insert a brass rod through the spindle hole and tap the center to jar it loose; you can then pull it out with your hand. To remove the tailstock center, run the spindle back as far as it will go by, turning the handwheel to the left. When the end of the tailstock screw bumps the back of the center, it will force the center out of the tapered hole. (See fig. 6-6.)

The ball bearing center shown in figure 6-26 is the most commonly used center for working between centers. As your work expands from the heat generated from machining, you should occasionally feel the area that houses the ball bearings to make sure they are not overheating. If the bearings become too warm, you will need to decrease the pressure of the center against the work.

For machining hollow cylinders, such as pipe, use a bull-nosed center called a pipe center. Figure 6-27 shows its construction. The taper shank (A) fits into the head and tail spindles in the same manner as the lathe centers. The conical disk (B) revolves freely on the collared end. Different size disks are supplied to accommodate various ranges of pipe sizes.

## LATHE DOGS

Lathe dogs are used with a driving plate or faceplate to drive work being machined on centers

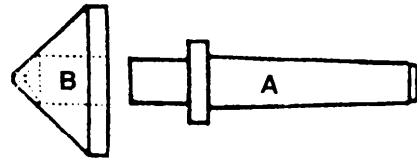


Figure 6-27.—Pipe center.

whenever the frictional contact alone between the live center and the work is not sufficient to drive the work.

The common lathe dog shown at the left in figure 6-28 is used for round work or work that has a regular section (square, hexagon, octagon). The piece to be turned is held firmly in the hole (A) by the setscrew (B). The bent tail (C) projects through a slot or hole in the driving plate or faceplate so that when the faceplate revolves with the spindle, it also turns the work. The clamp dog illustrated at the right in figure 6-28 may be used for rectangular or irregularly shaped work. Such work is clamped between the jaws.

## CENTER REST

The center rest, also called the steady rest, is used for the following purposes:

Deleted—No permission granted for electronic copy.

Figure 6-28.—Lathe dogs.

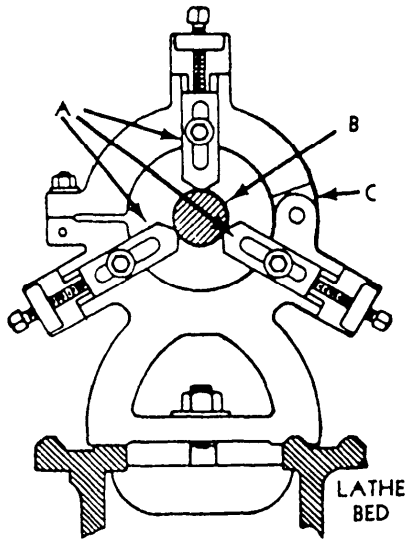


Figure 6-29.—Center rest.

- To provide an intermediate support or rest for long slender bars or shafts being machined between centers. It prevents them from springing due to cutting pressure or sagging as a result of their otherwise unsupported weight.
- To support and provide a center bearing for one end of work, such as a spindle, being bored or drilled from the end when it is too long to be

Deleted—No permission granted for electronic copy.

Figure 6-30.—Follower rest.

supported by the chuck alone. The center rest, kept aligned by the ways, can be clamped at any desired position along the bed, as illustrated in figure 6-29. It is important that the jaws (A) be carefully adjusted to allow the work (B) to turn freely and at the same time keep it accurately centered on the axis of the lathe. The top half of the frame is hinged at C to make it easier to place the center rest in position without removing the work from the centers or changing the position of the jaws.

### FOLLOWER REST

The follower rest is used to back up work of small diameter to keep it from springing under the pressure of cutting. This rest gets its name because it follows the cutting tool along the work. As shown in figure 6-30, it is attached directly to the saddle by bolts (B). The adjustable jaws bear directly on the finished diameter of the work opposite and above the cutting tool.

### TAPER ATTACHMENT

The taper attachment, illustrated in figure 6-31, is used for turning and boring tapers. It is bolted to the back of the carriage saddle. In operation, it is connected to the cross-slide so that it moves the cross slide laterally as the carriage moves longitudinally, thereby causing the cutting tool to move at an angle to the axis of the work to produce a taper.

Deleted—No permission granted for electronic copy.

Figure 6-31.—A taper attachment.

Deleted—No permission granted for electronic copy.

Figure 6-32.—Thread dial indicator.

The angle of the desired taper is set on the guide bar of the attachment, and the guide bar support is clamped to the lathe bed.

Since the cross-slide is connected to a shoe that slides on the guide bar, the tool follows along a line that is parallel to the guide bar and hence at an angle to the work axis corresponding to the desired taper.

The operation and application of the taper attachment will be explained further later in this chapter.

## THREAD DIAL INDICATOR

The thread dial indicator, shown in figure 6-32, lets you quickly return the carriage to the beginning of the thread to set up successive cuts. This eliminates the necessity of reversing the lathe and waiting for the carriage to follow the thread back to its beginning. The dial, which is geared to the lead screw, indicates when to clamp the half-nuts on the lead screw for the next cut.

The threading dial consists of a worm wheel that is attached to the lower end of a shaft and meshed with the lead screw. The dial is located on the upper end of the shaft. As the lead screw revolves, the dial turns. The graduations on the dial indicate points at which the half-nuts may be engaged. When the threading dial is not being used, it should be disengaged from the lead screw to prevent unnecessary wear to the worm wheel.

## CARRIAGE STOP

You can attach the carriage stop to the bed at any point where you want to stop the carriage. The carriage stop is used principally in turning, facing, or boring duplicate parts; it eliminates the need for repeated measurements of the same dimension. To operate the carriage stop, set the stop at the point where you want to stop the feed. Just before the carriage reaches this point, shut off the automatic feed and carefully run the carriage up against the stop.

Carriage stops are provided with or without micrometer adjustment. Figure 6-33 shows a micrometer carriage stop. Clamp it on the ways in the approximate position required and then adjust it to the exact setting using the micrometer adjustment. (NOTE: Do not confuse this stop with the automatic carriage stop that automatically stops the carriage by disengaging the feed or stopping the lathe.)

## GRINDING ATTACHMENT

The grinding attachment, illustrated in figure 6-34, is a portable grinder with a base that fits on the compound rest in the same manner as the toolpost. Like the cutting tool, the grinding attachment can be fed to the work at any angle. It is used for grinding hard-faced valve disks and seats, for grinding lathe centers, and for all kinds of cylindrical grinding. For internal grinding, small wheels are used on special quills (extensions) screwed onto the grinder shaft.

Deleted—No permission granted for electronic copy.

Figure 6-33.—Micrometer carriage stop.

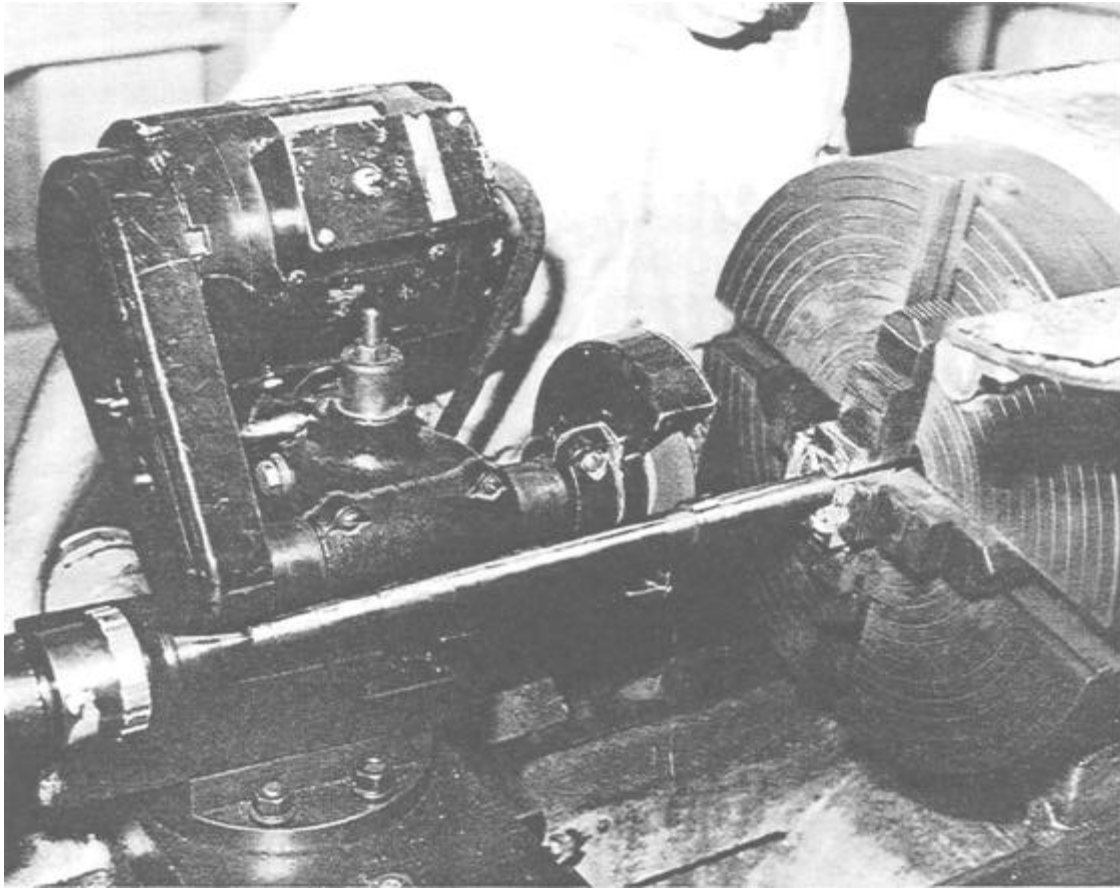


Figure 6-34.—Grinder mounted on a compound rest.

28.101

## MILLING ATTACHMENT

The milling attachment adapts the lathe to perform milling operations on small work, such as cutting keyways, slotting screwheads, machining flats, and milling dovetails. Figure 6-35 illustrates the setup for milling a dovetail.

The milling cutter is held in an arbor driven by the lathe spindle. The work is held in a vise on the milling attachment. The milling attachment is mounted on the cross-slide and therefore its movement can be controlled by the longitudinal feed and cross feed of the lathe. The depth of the cut is regulated by the longitudinal feed while the length of the cut is regulated by the cross feed. Vertical motion is controlled by the adjusting screw at the top of the attachment. The vise can be set at any angle in a horizontal or vertical plane. A milling attachment is unnecessary in shops equipped with milling machines.

Deleted—No permission  
granted for electronic copy.

Figure 6-35.—Milling attachment.

## TRACING ATTACHMENTS

A tracing attachment for a lathe is useful whenever you have to make several parts that are identical in design. A tracer is a hydraulically actuated attachment that carries the cutting tool on a path identical to the shape and dimensions of a pattern or template of the part to be made. The major parts of the attachment are a hydraulic power unit, a tracer valve to which the stylus that follows the template is attached, a cylinder and slide assembly that holds the cutting tool and moves in or out on the command of the tracer valve hydraulic pressure output, and a template rail assembly that holds the template of the part to be made. There are several different manufacturers of tracers, and each tracer has a slightly different design and varying operating features. Tracers can be used for turning, facing, and boring and are capable of maintaining a dimensional tolerance equal to that of the lathe being used. Templates for the tracer can be made from either flat steel or aluminum plate or from round bar stock. It is important that the template be exactly like the finished part you require. Any scratch, dent, or mismachined dimension will be reproduced on the parts to be made.

## OTHER TYPES OF ENGINE LATHES

The type of engine lathe that has been described in this chapter is the general-purpose, screw-cutting, precision lathe that is universally used in the machine shops of ships in the Navy. Repair ships also carry other types. A short description of some other types follows.

A bench lathe (fig. 6-36) is a small engine lathe mounted on a bench. Such lathes are sometimes used in the toolroom of repair ships.

The gap (extension) lathe shown in figure 6-37 has a removable bed piece shown on the deck in front of the lathe. This piece can be removed from the lathe bed to create a gap into which work of larger diameter may be swung. Some gap lathes are designed so that the ways can be moved longitudinally to create the gap.

## LATHE SETUP

Before an aircraft is permitted to take off, the pilot and crew must go through a check-out procedure to determine whether the engines, controls, and safety features are in proper operating condition. The same applies to an engine lathe. Part of this procedure is to make sure the lathe is set up properly. Before starting a lathe machining operation, always make sure the machine is set up for the job you are doing. If the work is mounted between centers, check the alignment of the dead center with the live center and make any required changes. Ensure that the toolholder and the cutting tool are set at the proper height and angle. Check the workholding accessory to make sure the workpiece is held securely. Use the center rest or follower rest to support long workpieces.

## LATHE SAFETY

In machine operations, there is one sequence of events that you must always follow. **SAFETY FIRST, ACCURACY SECOND, AND SPEED**

Deleted—No permission  
granted for electronic copy.

Figure 6-36.—A bench lathe.



**LAST.** As with any shop equipment you must observe all posted safety precautions. Review your equipment operators manual for safety precautions and any chapters of *Navy Occupational Safety and Health (NAVOSH) Program Manual for Forces Afloat*, OPNAV Instruction 5100.19B, which pertain to the equipment you will be operating.

## ALIGNING AND LEVELING

Alignment and levelness must be correct to ensure proper operation of all engine lathes. They must be aligned and leveled when installed and must be checked periodically. Since the information provided here is only a brief overview, you should follow the machines' manufacturers instructions.

The three basic methods of aligning and leveling lathes are spirit method, optical, and test bar. The optical method requires special equipment. If your ship or shore station has an optical shop, they may be able to optically align your lathes or there are civilian companies that provide this service. Since Machinery Repairman do not optically align lathes, we will only discuss the spirit level and test bar methods.

You should remember that the spirit level method will work well at shore stations, but it will produce

only approximate levelness aboard ship. The test bar method is the most accurate for shipboard use.

The leveling of lathes actually refers to the removal of the twist in the bed. This twist results from setting the machine on an uneven foundation. The machine is leveled by adjusting one or more legs to remove the twist in the bed so that it is straight and parallel with the spindle.

### The Spirit Level Method

The leveling, or untwisting, of a lathe requires the use of a very accurate level. An ordinary carpenter's or machinist's level is not sufficiently accurate for leveling lathes. A sensitive, graduated-tube spirit level reading to 10 seconds of arc per graduation (0.0006 inch per foot) is required. The level should be adjustable and should have both a short base and a long tube.

The procedure for leveling engine lathes is as follows:

1. Loosen the lag screws that hold the right end legs to the deck. Do not loosen the lag screws on the left end (headstock) legs.

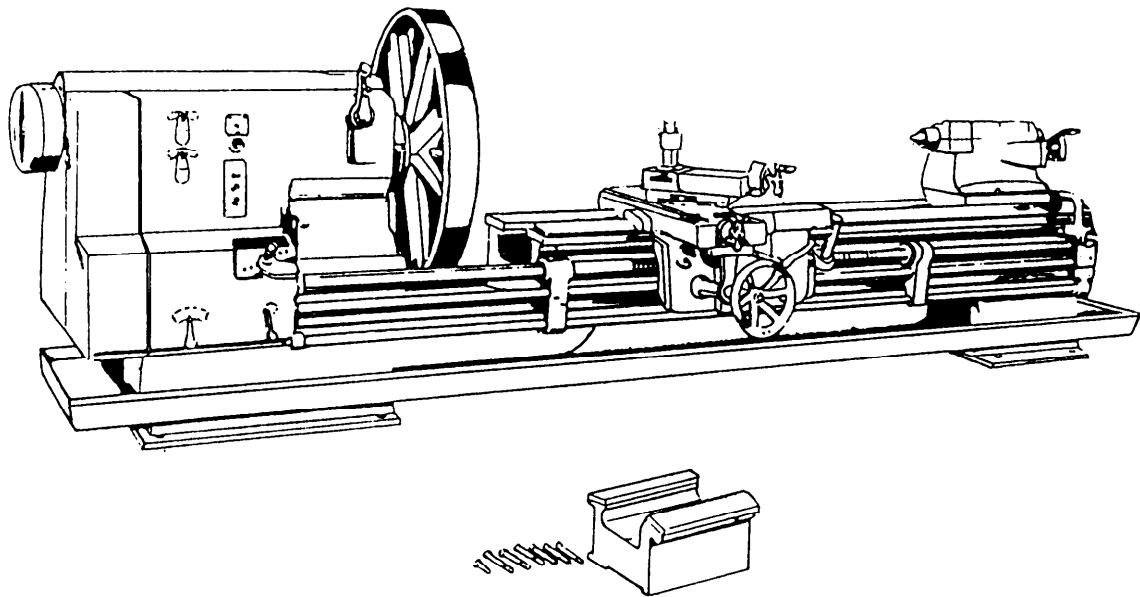


Figure 6-37.—A gap lathe.

2. Place the level across the bed at a right angle to the center line of the bed near the headstock (as shown in view A fig. 6-38). Adjust the level until the bubble is in the center and allow at least 30 seconds for the bubble to come to rest.

3. Without changing its adjustment, move the level to the other end of the ways and place it again at a right angle to the center line of the bed (as shown in view B, fig. 6-38). Then, by adjusting the leveling

screws on the right-hand legs, bring the bubble to center. If the machine does not have leveling screws, use steel shims under the legs.

4. Repeat steps 2 and 3 until the difference in the bubble readings at the two positions is less than one division.

5. Tighten the lag screws and repeat steps 2 and 3 as a final check.

Deleted—No permission  
granted for electronic copy.

**Figure 6-38.—A. Placing the level at right angles to the center line of the back of the headstock. B. placing the level at right angles to the center line of the bed at the outer end of the ways.**

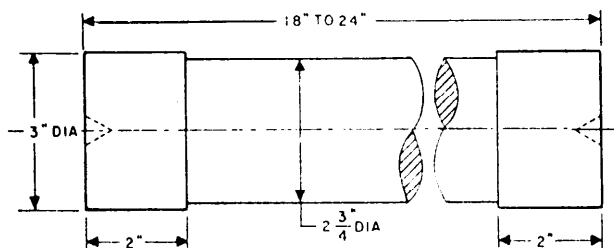


Figure 6-39.—Lathe alignment test bar.

### The Test Bar Method

The first step in the test bar method is to make the test bar. A test bar may be any metal bar, 3 inches in diameter and approximately 18 to 24 inches long. (See fig. 6-39 for a sample). Next take a light cut on each end of the test bar **WITHOUT CHANGING THE TOOL SETTING**. Measure the diameter of each end. A difference in diameter indicates a misalignment. Adjust the machine leveling screws and repeat the procedure until a cut on both ends of the test bar results in the same diameter.

### PREPARING THE CENTERS

The first step in preparing the centers is to see that they are accurately mounted in the headstock and tailstock spindles. The centers and the tapered holes in which they are fitted must be perfectly clean.

Chips and dirt left on the contact surfaces will impair accuracy by preventing a perfect fit of the bearing surfaces. Be sure that there are no burrs in the spindle hole. If you find burrs, remove them by carefully scraping or reaming the surface with a Morse taper reamer. Burrs will produce the same inaccuracies as chips and dirt.

Center points must be accurately finished to an included angle of 60°. Figure 6-40 shows the method of checking the angle with a center gauge. The large notch of the center gauge is intended for this particular purpose. If the test shows that the point is not perfect, true the point in the lathe by taking a cut over the point with the compound rest set at 30°. To true a hardened tail center, either anneal it and then machine it or grind it if a grinding attachment is available.

### Aligning and Testing

To turn a shaft straight and true between centers, be sure the centers are in the same plane parallel to the ways of the lathe. You can align the centers by releasing the tailstock from the ways and then moving the tailstock laterally with two adjusting screws. At the rear of the tailstock are two zero lines, and the centers are approximately aligned when these lines coincide. To check the approximate alignment, move the tailstock up until the centers almost touch and observe their relative positions as shown in

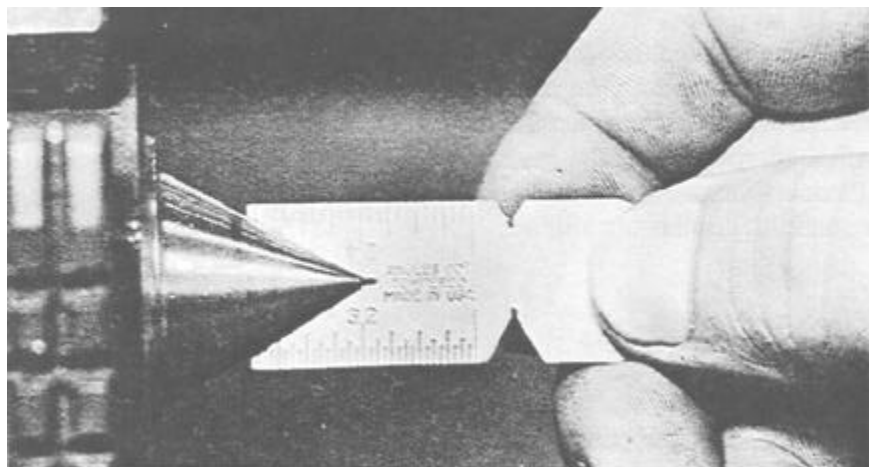


Figure 6-40.—Checking the center point with a center gauge.

Deleted—No permission granted for electronic copy.

Figure 6-41.—Aligning lathe centers.

figure 6-41. To produce very accurate work, especially if it is long, use the following procedure to determine and correct errors in alignment not otherwise detected.

Mount the work to be turned, or a piece of stock of similar length, on the centers. With a turning tool in the toolpost, take a small cut to a depth of a few thousandths of an inch at the headstock end of the work. Then, remove the work from the centers to allow the carriage to be run back to the tailstock without withdrawing the tool. Do not touch the tool setting. Replace the work in the centers, and with the tool set at the previous depth take another cut coming in from the tailstock end. Compare the diameters of these cuts with a micrometer. If the diameters are exactly the same, the centers are in perfect alignment. If they are different, adjust the tailstock in the direction required by using the setover adjusting screws. Repeat the test and adjustment until a cut at each end produces equal diameters.

Another method you can use to check for positive alignment of lathe centers is to take a light cut over the work held between the centers. Then, measure the work at each end with a micrometer. If the readings differ, adjust the tailstock to remove the difference. Repeat the procedure until the centers are aligned.

### Truing Centers

To machine or true a lathe center, remove the faceplate from the spindle. Then, insert the live center into the spindle and set the compound rest at an angle of  $30^\circ$  with the axis of the spindle, as shown in figure 6-42. If you are using a three- or four-jaw chuck, secure the material that you are using to manufacture your center from in the chuck and proceed from this point. Place a round-nose tool in the toolpost and set the cutting edge of the tool at the

exact center point of the lathe center. Machine a light cut on the center point and test the point with a center gauge. All lathe centers, regardless of their size, are finished to an included angle of  $60^\circ$ .

If you must regrind a dead center for the tailstock, it is best to do it using a cylindrical grinder. The cylindrical grinder will be covered in chapter 10.

### SETTING THE TOOLHOLDER AND CUTTING TOOL

The first requirement for setting the tool is to have it rigidly mounted on the toolpost holder. Be sure the tool sits squarely in the toolpost and that the setscrew is tight. Reduce overhang as much as possible to prevent the tool from springing during cutting. If the tool has too much spring, the point of the tool will catch in the work, causing chatter and damaging both the tool and the work. The relative distances of A and B in figure 6-43 show the correct overhang for the tool bit and the holder. When a quick-change toolholder is used, tool overhang should not exceed twice the width of the cutting tool, or of the shank, when you use a carbide insert cutting tool.

The point of the tool must be correctly positioned on the work. When you are using a high-speed cutting tool to straight turn steel, cast iron, and other relatively hard metals, set the point about  $5^\circ$  above center. A rule measurement of approximately  $3/64$

Deleted—No permission granted for electronic copy.

Figure 6-42.—Machining a lathe center.

## METHODS OF HOLDING THE WORK

You cannot perform accurate work if the work is improperly mounted. The following are requirements for proper mounting:

- The work center line must be accurately centered along the axis of the lathe spindle.
- The work must be held rigidly while being turned.
- The work must not be sprung out of shape by the holding device.
- The work must be adequately supported against any sagging caused by its own weight and against springing caused by the action of the cutting tool.

There are four general methods of holding work in the lathe: (1) between centers, (2) on a mandrel, (3) in a chuck, and (4) on a faceplate. Work may also be clamped to the carriage for boring and milling; the boring bar or milling cutter is held and driven by the headstock spindle.

### Holding Work Between Centers

To machine a workpiece between centers, drill center holes in each end to receive the lathe centers. Secure a lathe dog to the workpiece and then mount the work between the live and dead centers of the lathe.

**CENTERING THE WORK.**—To center drill round stock such as drill-rod or cold-rolled steel, secure the work to the head spindle in a universal chuck or a draw-in collet chuck. If the work is too long and too large to be passed through the spindle, use a center rest to support one end. It is good shop practice to first take a light finishing cut across the face of the end of the stock to be center drilled. This will provide a smooth and even surface and will help prevent the center drill from “wandering” or breaking. The centering tool is held in a drill chuck in the tailstock spindle and fed to the work by the tailstock handwheel (fig. 6-44).

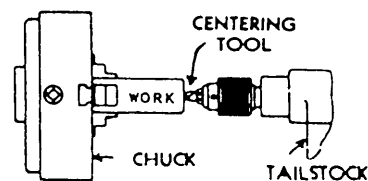


Figure 6-44.—Drilling center hole.

Deleted—No permission granted for electronic copy.

Figure 6-43.—Tool overhang.

inch times the diameter of the workpiece equals  $5^\circ$ . The point of a high-speed steel cutting tool being used to cut aluminum should be set slightly more than  $5^\circ$  above center, while the points of tools used to cut copper, brass, and other soft metals should be set exactly on center. The point of cast alloy (stellite and so on), carbide, and ceramic cutting tools should be placed exactly on center regardless of the material being cut. The tool point should be placed on center for threading, turning tapers, parting (cutting-off), or boring.

You can adjust the height of the tool in the toolholder illustrated in figure 6-43 by moving the half-moon wedge beneath the toolholder in or out as required. The quick-change toolholder has an adjusting screw to stop the tool at the correct height. Some square turret toolholders require a shim beneath the tool to adjust the height.

There are several methods you can use to set a tool on center. You can place a dead center in the tailstock and align the point of the tool with the point of the center. The tailstock spindle on many lathes has a line on the side that represents the center. You can also place a 6-inch rule against the workpiece in a vertical position and move the cross-slide in until the tool lightly touches the rule and holds it in place. Look at the rule from the side to determine if the height of the tool is correct. The rule will be straight up and down when the tool is exactly on center and will be at an angle when the tool is either high or low.

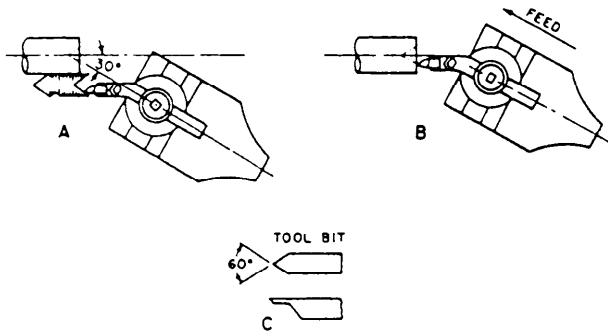


Figure 6-45.—Boring center hole.

If you must center a piece very accurately, bore the tapered center hole after you center drill to correct any run-out of the drill. You can do this by grinding a tool bit to fit a center gauge at a  $60^\circ$  angle. Then, with the toolholder held in the toolpost, set the compound rest at  $30^\circ$  with the line of center as shown in figure 6-45. Set the tool exactly on the center for height and adjust the tool to the proper angle with the center gauge as shown at A. Feed the tool as shown at B to correct any runout of the center. The tool bit should be relieved under the cutting edge as shown at C to prevent the tool from dragging or rubbing in the hole.

For center drilling a workpiece, the combined drill and countersink is the most practical tool. Combined drills and countersinks vary in size and the drill points also vary. Sometimes a drill point on one end will be  $1/8$  inch in diameter and the drill point on the opposite end will be  $3/16$  inch in diameter. The angle of the center drill is always  $60^\circ$  so that the countersunk hole will fit the angle of the lathe center point.

In center drilling, use a drop or two of oil on the drill. Feed the drill slowly and carefully to prevent breaking the tip. Use extreme care when the work is heavy, because it is then more difficult to “feel” the proper feed of the work on the center drill.

If the center drill breaks in countersinking and part of the broken drill remains in the work, you must remove the broken part. Sometimes you can jar it loose, or you may have to drive it out by using a chisel. But it may stick so hard that you cannot easily remove it. If so, anneal the broken part of the drill and drill it out.

The importance of having proper center holes in the work and a correct angle on the point of the lathe centers cannot be overemphasized. To do an accurate job between centers on the lathe, you must

Deleted—No permission granted for electronic copy.

Figure 6-46.—Examples of center holes.

countersink holes of the proper size and depth and be sure the points of the lathe centers are true and accurate.

Figure 6-46 shows correct and incorrect countersinking for work to be machined on centers. In example A, the correctly countersunk hole is deep enough so that the point of the lathe centers does not come in contact with the bottom of the hole.

In example B of figure 6-46, the countersunk hole is too deep, causing only the outer edge of the work to rest on the lathe center. Work cannot be machined on centers countersunk in this manner.

Example C shows a piece of work that has been countersunk with a tool having too large an angle. This work rests on the point of the lathe center only. It is evident that this work will soon destroy the end of the lathe center, thus making it impossible to do an accurate job.

**MOUNTING THE WORK.**—Figure 6-47 shows correct and incorrect methods of mounting work between centers. In the correct example, the driving dog is attached to the work and rigidly held by the setscrew. The tail of the dog rests in the slot of the drive plate and extends beyond the base of the slot so that the work rests firmly on both the headstock center and tailstock center.

In the incorrect example, the tail of the dog rests on the bottom of the slot on the faceplate at A, thereby pulling the work away from the center points, as shown at B and C, causing the work to revolve eccentrically.

Deleted—No permission  
granted for electronic copy.

Figure 6-47.—Examples of work mounted between centers.

When you mount work between centers for machining, there should be no end play between the work and the dead center. However, if the work is held too tightly by the tail center, when the work begins revolving it will heat the center point and destroy both the center and the work. To prevent overheating, lubricate the tail center with a heavy oil or a lubricant specially made for this purpose. If you are using a ball bearing center, no lubricant is necessary.

### Holding Work on a Mandrel

Many parts, such as bushings, gears, collars, and pulleys, require all the finished external surfaces to run true with the hole that extends through them. That is, the outside diameter must be true with the inside diameter or bore.

A mandrel is simply a round piece of steel of convenient length that has been centered and turned true with the centers. Commercial mandrels are made of tool steel, hardened and ground with a slight taper (usually 0.0005 inch per inch). On sizes up to 1 inch the small end is usually one-half of one thousandth of an inch under the standard size of the mandrel, while on larger sizes this dimension is usually one thousandth of an inch under standard. This taper allows the standard hole in the work to vary according to the usual shop practice, and still provides the necessary fit to drive the work when the mandrel is pressed into the hole. However, the taper is not great enough to distort the hole in the work. The

countersunk centers of the mandrel are lapped for accuracy, while the ends are turned smaller than the body of the mandrel and are provided with flats, which give a driving surface for the lathe dog.

General practice is to finish the hole to a standard size, within the limit of the accuracy desired. Thus, a 3/4-inch standard hole will have a finished dimension of from 0.7505 to 0.7495 inch, or a tolerance of one-half of one thousandth of an inch above or below the true standard size of exactly 0.750 inch. First, drill or bore the hole to within a few thousandths of an inch of the finished size; then remove the remainder of the material with a machine reamer.

Press the piece on a mandrel tightly enough so the work will not slip while it is machined and clamp a dog on the mandrel, which is mounted between centers. Since the mandrel surface runs true with respect to the lathe axis, the turned surfaces of the work on the mandrel will be true with respect to the hole in the piece.

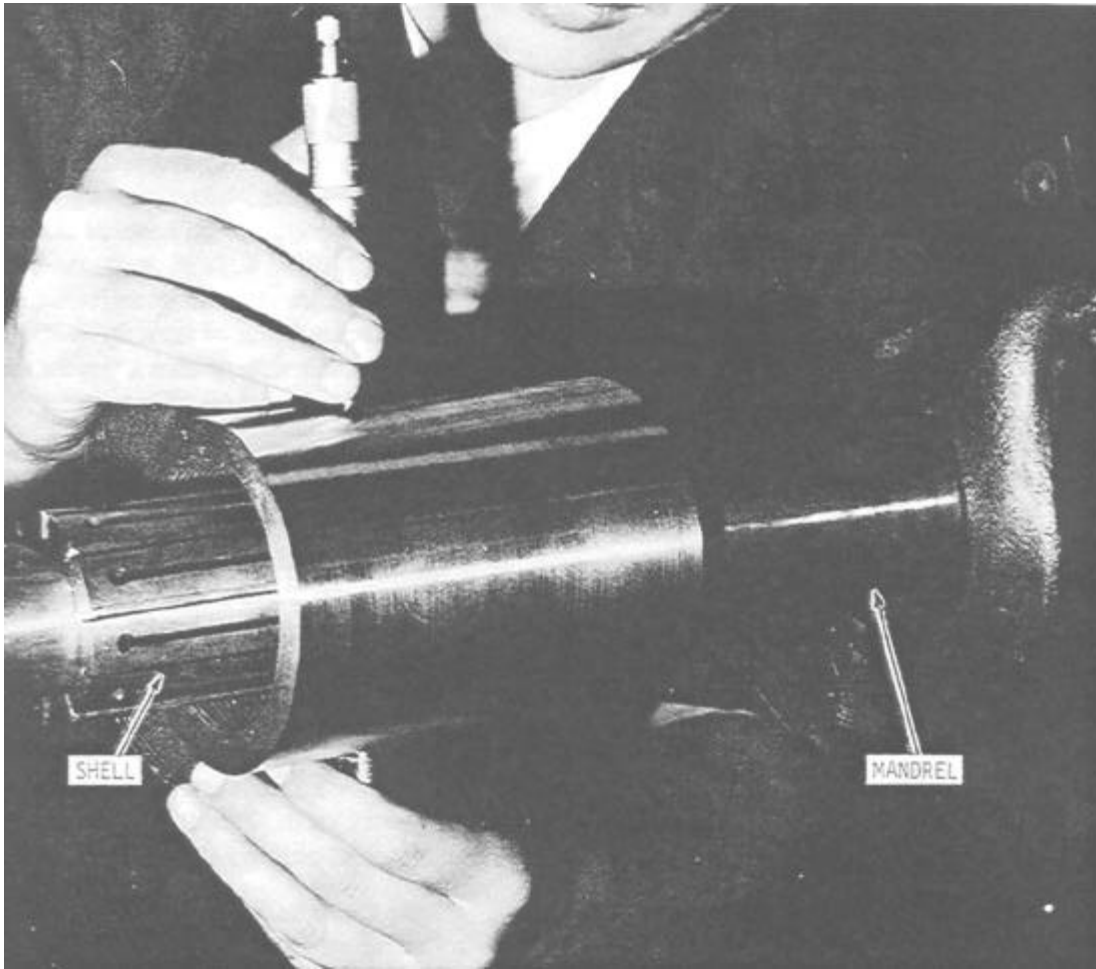
The size of the mandrel is always marked on the large end to avoid error and for convenience in placing work on it. The work is driven or pressed on from the small end and removed the same way.

When the hole in the work is not standard size, or if no standard mandrel is available, make a soft mandrel to fit the particular piece to be machined.

Use a few drops of oil to lubricate the surface of the mandrel before pressing it into the work, because clean metallic surfaces gall or stick when pressed together. If you do not use lubricant, you will not be able to drive the mandrel out without ruining the work.

Whenever you machine work on a mandrel, be sure the lathe centers are true and accurately aligned; otherwise, the finished turned surface will not be true. Before turning accurate work, test the mandrel on centers before placing any work on it. The best test for runout is one made with a dial indicator. Mount the indicator on the toolpost so the point of the indicator just touches the mandrel. As the mandrel is turned slowly between centers, any runout will be registered on the indicator dial.

If runout is indicated and you cannot correct it by adjusting the tailstock, the mandrel itself is at fault (assuming that the lathe centers are true) and cannot be used. The countersunk holes may have been damaged, or the mandrel may have been bent by careless handling. Be sure you always protect the



28.116

Figure 6-48.—A split-shell expansion mandrel.

ends of the mandrel when you press or drive it into the work. A piece of work mounted on a mandrel must have a tighter press fit to the mandrel for roughing cuts than for finishing cuts. Thick-walled work can be left on the mandrel for the finishing cut, but thin-walled work should be removed from the mandrel after the roughing cut and lightly reloaded on the mandrel before the finish cut is taken.

In addition to the standard lathe mandrel just described, there are expansion mandrels, gang mandrels, and eccentric mandrels.

An **EXPANSION** mandrel is used to hold work that is reamed or bored to nonstandard size. Figure 6-48 shows an expansion mandrel composed of two parts: a tapered pin that has a taper of approximately 1/16 inch for each inch of length and an outer split shell that is tapered to fit the pin. The split shell is placed in the work and the tapered pin is forced into

the shell, causing it to expand until it holds the work properly.

A **GANG** mandrel (fig. 6-49) is used for holding several duplicate pieces such as gear blanks. The pieces are held tightly against a shoulder by a nut at the tailstock end.

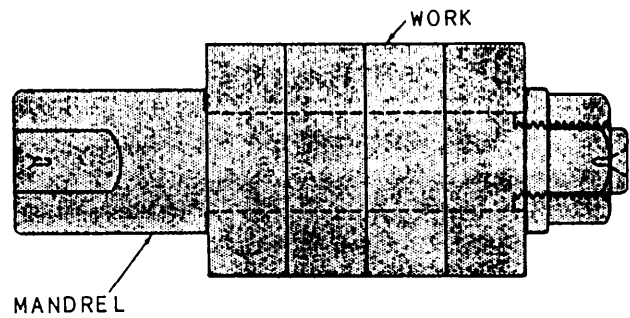


Figure 6-49.—Gang mandrel.



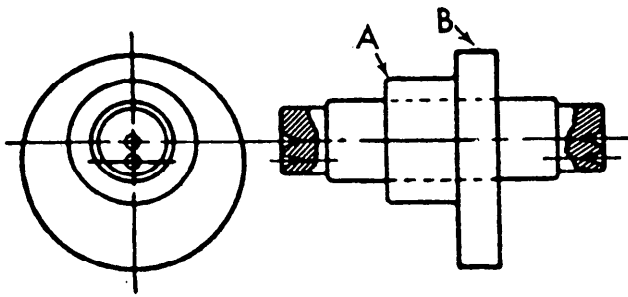


Figure 6-50.—Work on an eccentric mandrel.

An **ECCENTRIC** mandrel has two sets of countersunk holes, one pair of which is off-center an amount equal to the eccentricity of the work to be machined. Figure 6-50 illustrates its application: A is to be machined concentric with the hole in the work, while B is to be machined eccentric to it.

### Holding Work In Chucks

The independent chuck and universal chuck are used more often than other workholding devices in lathe operations. A universal chuck is used for holding relatively true cylindrical work when accurate concentricity of the machined surface and holding power of the chuck are secondary to the time required to do the job. An independent chuck is used when the work is irregular in shape, must be accurately centered, or must be held securely for heavy feeds and depth of cut.

#### FOUR-JAW INDEPENDENT CHUCK.—

Figure 6-51 shows a rough casting mounted in a four-jaw independent lathe chuck on the spindle of the lathe. Before truing the work, determine which part you wish to turn true. To mount a rough casting in the chuck, proceed as follows:

1. Adjust the chuck jaws to receive the casting. Each jaw should be concentric with the ring marks indicated on the face of the chuck. If there are no ring marks, set the jaws equally distant from the circumference of the chuck body.

2. Fasten the work in the chuck by turning the adjusting screw on jaw No. 1 and jaw No. 3, a pair of jaws which are opposite each other. Next tighten jaws No. 2 and No. 4 (opposite each other).

3. At this stage the work should be held in the jaws just tightly enough so it will not fall out of the chuck while being trued.

4. Revolve the spindle slowly, and with a piece of chalk mark the high spot (A in fig. 6-51) on the work while it is revolving. Steady your hand on the toolpost while holding the chalk.

5. Stop the spindle. Locate the high spot on the work and adjust the jaws in the proper direction to true the work by releasing the jaw opposite the chalk mark and tightening the one nearest the tank.

6. Sometimes the high spot on the work will be located between adjacent jaws. When it is, loosen the two opposite jaws and tighten the jaws adjacent to the high spot.

7. When the work is running true in the chuck, tighten the jaws gradually, working the jaws in pairs as described previously, until all four jaws clamp the work tightly. Be sure that the back of the work rests flat against the inside face of the chuck, or against the faces of the jaw stops (B in figure 6-51).

Use the same procedure to clamp semi-finished or finished pieces in the chuck, except center these pieces more accurately in the chuck. If the runout tolerance is very small, use a dial indicator to determine the runout.

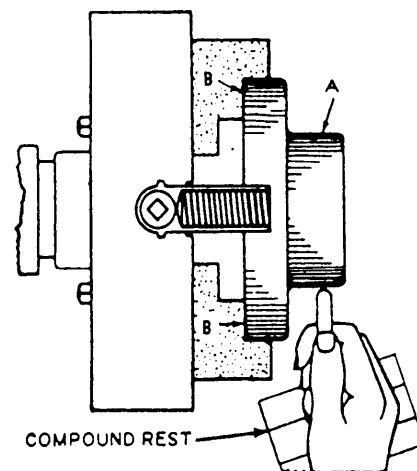


Figure 6-51.—Work mounted in a four-jaw independent chuck.

Deleted—No permission granted for electronic copy.

Figure 6-52.—Centering work with a dial indicator.

Figure 6-52 illustrates the use of a dial test indicator in centering work that has a hole bored in its center. As the work is revolved, the high spot is indicated on the dial of the instrument to a thousandth of an inch. The jaws of the chuck are adjusted on the work until the indicator hand registers no deviation as the work is revolved.

When the work consists of a number of duplicate parts that are to be tightened in the chuck, release two adjacent jaws and remove the work. Place another piece in the chuck and retighten the two jaws just released.

Each jaw of a lathe chuck, whether an independent or a universal chuck, has a number stamped on it to correspond to a similar number on the chuck. When you remove a chuck jaw for any reason, always put it back into the proper slot.

When the work to be chucked is frail or light, tighten the jaw carefully so the work will not bend, break, or spring.

To mount rings or cylindrical disks on a chuck, expand the chuck jaws against the inside of the workpiece. (See fig. 6-53.)

Regardless of how you mount the workpiece, NEVER leave the chuck wrench in the chuck while the chuck is on the lathe spindle. If the lathe should be started, the wrench could fly off the chuck and injure you or a bystander.

**THREE-JAW UNIVERSAL CHUCK.**—A three-jaw universal, or scroll, chuck allows all jaws to move together or apart in unison. A universal chuck will center almost exactly at the first clamping, but after a period of use it may develop inaccuracies of from 0.002 to 0.010 inch in centering the work, requiring the runout of the work to be corrected.

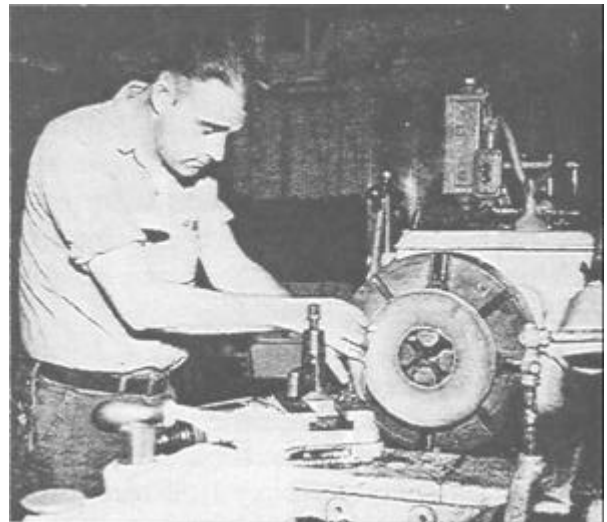
Sometimes you can make the correction by inserting a piece of paper or thin shim stock between the jaw and the work on the **HIGH SIDE**.

When you chuck thin sections, be careful not to clamp the work too tightly, since the diameter of the piece will be machined while the piece is distorted. Then, when you release the pressure of the jaws after finishing the cut, there will be as many high spots as there are jaws, and the turned surface will not be true.

**DRAW-IN-COLLET CHUCK.**—A draw-in collet chuck is used for very fine accurate work of small diameter. Long work can be passed through the hollow drawbar, and short work can be placed directly into the collet from the front. Tighten the collet on the work by rotating the drawbar handwheel to the right. This draws the collet into the tapered closing sleeve. Turn the handle to the left to release the collet.

You will get the most accurate results when the diameter of the work is the same as the dimension stamped on the collet. The actual diameter of the work may vary from the collet dimension by 0.001 inch. However, if the work diameter varies more than this, the accuracy of the finished work will be affected. Most draw-in collet chuck sets are sized in 1/64-inch increments to allow you to select a collet within the required tolerances.

**RUBBER FLEX COLLET CHUCK.**—A rubber flex collet chuck is basically the same as the draw-in collet, except that the size of the stock held is not as critical. The rubber collets are graduated in



28.121  
Figure 6-53.—Work held from inside by a four-jaw independent chuck.

Deleted—No permission  
granted for electronic copy.

Deleted—No permission  
granted for electronic copy.

**Figure 6-54.—Eccentric machining of work mounted on a faceplate.**

1/16-inch steps and will tighten down with accuracy on any size within the 1/16-inch range.

**CARE OF CHUCKS.**—To preserve a chuck's accuracy, handle it carefully and keep it clean. Never force a chuck jaw by using a pipe as an extension on the chuck wrench.

Before mounting a chuck, remove the live center and fill the hole with a rag to prevent chips and dirt from getting into the tapered hole of the spindle.

Clean and oil the threads of the chuck and the spindle nose. Dirt or chips on the threads will not allow the chuck to seat properly against the spindle shoulder and will prevent the chuck from running true. Since there are a number of different ways that chucks mount to machines, you must refer to your operators manual for mounting instructions.

When you mount or remove a heavy chuck, lay a board across the bedways to protect them and to help support the chuck as you put it on or take it off. Most larger chucks are drilled and tapped to accept a pad eye for lifting with a chainfall.

The procedures for mounting and removing faceplates are the same as for mounting and removing chucks.

### **Holding Work On a Faceplate**

A faceplate is used for mounting work that cannot be chucked or turned between centers because of its peculiar shape. A faceplate is also used when holes are to be accurately machined in flat work, as in figure 6-54, or when large and irregularly shaped work is to be faced on the lathe.

**Figure 6-55.—Work damped to an angle plate.**

Work is secured to the faceplate by bolts, clamps, or any suitable clamping means. The holes and slots in the faceplate are used to anchor the holding bolts. Angle plates may be used to locate the work at the desired angle, as shown in figure 6-55. (Note the counterweight added for balance.)

For work to be mounted accurately on a faceplate, the surface of the work in contact with the faceplate must be accurate. Check the accuracy with a dial indicator. If you find runout, reface the surface of the work that is in contact with the faceplate. It is good practice to place a piece of paper between the work and the faceplate to keep the work from slipping.

Before securely clamping the work, move it about on the surface of the faceplate until the point to be machined is centered accurately over the axis of the lathe. Suppose you wish to bore a hole, the center of which has been laid out and marked with a prick punch. First, clamp the work to the approximate position on the faceplate. Then, slide the tailstock up to where the dead center just touches the work. Note, the dead center should have a sharp, true point. Now revolve the work slowly and, if the work is off center, the point of the dead center will scribe a circle on the work. If the work is on center, the point of the dead center will coincide with the prick punch mark.

Deleted—No permission granted for electronic copy.

Deleted—No permission granted for electronic copy.

**Figure 6-56.—Work mounted on a carriage for boring.**

### **Holding Work On the Carriage**

If a piece of work is too large or bulky to swing conveniently in a chuck or on a faceplate, you can bolt it to the carriage or the cross slide and machine it with a cutter mounted on the spindle. Figure 6-56 shows a piece of work being machined by a fly cutter mounted in a boring bar that is held between centers and driven by a lathe dog.

### **Using the Center Rest and Follower Rest**

Long slender work often requires support between its ends while it is turned; otherwise the work would spring away from the tool and chatter. The center rest is used to support such work so it can be turned accurately at a faster feed and cutting speed than would be possible without the center rest. (See fig. 6-57).

Place the center rest where it will give the greatest support to the piece to be turned. This is usually at about the middle of its length.

Ensure that the center point between the jaws of the center rest coincides exactly with the axis of the lathe spindle. To do this, place a short piece of stock in a chuck and machine it to the diameter of the workpiece to be supported. Without removing the stock from the chuck, clamp the center rest on the ways to the lathe and adjust the jaws to the machined surface. Without changing the jaw settings, slide the center rest into position to support the workpiece. Remove the stock used for setting the center rest and set the workpiece in place. Use a dial indicator to true

**Figure 6-57.—Use of a center rest to support work between centers**

the workpiece at the chuck. Figure 6-58 shows how a chuck and center rest are used to machine the end of a workpiece.

The follower rest differs from the center rest in that it moves with the carriage and provides support against the forces of the cut. To use the tool, turn a “spot” to the desired finish diameter and about 5/8 to 3/4 inch wide on the workpiece. Then, adjust the jaws of the follower rest against the area you just machined. The follower rest will move with the cutting tool and support the point being machined.

The follower rest (fig. 6-59) is indispensable for chasing threads on long screws, as it allows the cutting of a screw with a uniform pitch diameter. Without the follower rest, the screw would be inaccurate because it would spring away from the tool.

Deleted—No permission granted for electronic copy.

**Figure 6-58.—Work mounted in a chuck and center rest.**

Use a sufficient amount of grease, oil or other available lubricant on the jaws of the center rest and follower rest to prevent “seizing” and scoring the workpiece. Check the jaws frequently to see that they do not become hot. The jaws may expand slightly if they get hot and push the work out of alignment (when the follower rest is used) or bind (when the center rest is used). If you are using a center rest or follower rest that is equipped with ball bearings, no lubrication is necessary.

## ENGINE LATHE OPERATIONS

Up to this point, you have studied the preliminary steps leading up to performing machine work on the lathe. You have learned how to mount the work and the tool, and which tools are used for various purposes. The next step is to learn how to use the lathe. We will now cover some of the basic operations that you will accomplish on the engine lathe.

Remember that accuracy is the prime requisite of a good machine job; so before you start, be sure that the centers are true and properly aligned, that the work is mounted properly, and that the cutting tools are correctly ground and sharpened.

As we cover the various operations that you will perform on a lathe, remember the tooling used in your shop may be different from what is pictured in this manual. You may use different toolholders or cutting tools, but the operations are basically the same. Always remember that you are only limited by your

imagination as to the various tooling and setup combinations you can use.

## PLANNING THE JOB

It is important for you to study the blueprint of the part to be manufactured before you begin machining. Check over the dimensions and note the points or surfaces from which they are laid out. Plan the steps of your work in advance to determine the best way to proceed. Check the overall dimensions and be sure the stock you intend to use is large enough for the job. For example, small design features, such as collars on pump shafts or valve stems, will require that you use stock of much larger diameter than that required for the main features of the workpiece.

## CUTTING SPEEDS AND FEEDS

Cutting speed is the rate at which the surface of the work passes the point of the cutting tool. It is expressed in feet per minute (fpm).

To find the cutting speed, multiply the diameter of the work (DIA) in inches times 3.1416 times the number of revolutions per minute (rpm) and divide by 12.

$$CS = \frac{DIA \times 3.1416 \times rpm}{12}$$

The result is the peripheral or cutting speed in fpm. For example, a 2-inch diameter part turning at 100 rpm will produce a cutting speed of

$$\frac{2 \times 3.1416 \times 100}{12} = 52.36 \text{ fpm}$$

If you have selected a recommended cutting speed from a chart for a specific type of metal, you will need to figure what rpm is required to obtain the recommended cutting speed. Use the following formula:

$$rpm = \frac{CS \times 12}{DIA \times 3.1416}$$

Recommended cutting speeds in fpm for turning carbon and alloy steels using either high-speed steel or carbide tool bits can be found in the cutting speeds section of the current edition of the *Machinery's Handbook*.

Deleted—No permission granted for electronic copy.

Figure 6-59.—Follower rest supporting screw while thread is being cut.

FEED is the amount the tool advances in each revolution of the work. It is usually expressed in thousandths of an inch per revolution of the spindle. The index plate on the quick-change gear box indicates the setup for obtaining the feed desired. The amount of feed to use is best determined from experience.

Cutting speeds and tool feeds are determined by various considerations: the hardness and toughness of the metal being cut; the quality, shape, and sharpness of the cutting tool; the depth of the cut; the tendency of the work to spring away from the tool; and the rigidity and power of the lathe. Since conditions vary, it is good practice to find out what the tool and work will stand, and then select the most practical and efficient speed and feed consistent with the finish desired.

If the cutting speed is too slow, the job takes longer than necessary and the work produced is often unsatisfactory because of a poor finish. On the other hand, if the speed is too fast the tool edge will dull quickly and will require frequent regrinding. The cutting speeds possible are greatly affected by the use of a suitable cutting coolant. For example, steel that can be rough turned dry at 60 rpm can be turned at about 80 rpm when flooded coolant.

When **ROUGHING** parts down to size, use the greatest depth of cut and feed per revolution that the work, the machine, and the tool will stand at the highest practical speed. On many pieces, when tool failure is the limiting factor in the size of the roughing cut, it is usually possible to reduce the speed slightly and increase the feed to a point that the metal removed is much greater. This will prolong tool life. Consider an example of when the depth of cut is 1/4 inch, the feed is 20 thousandths of an inch per revolution, and the speed is 80 fpm. If the tool will not permit additional feed at this speed, you can usually drop the speed to 60 fpm and increase the feed to about 40 thousandths of an inch per revolution without having tool trouble. The speed is therefore reduced 25 percent, but the feed is increased 100 percent. The actual time required to complete the work is less with the second setup.

On the **FINISH TURNING OPERATION**, a very light cut is taken since most of the stock has been removed on the roughing cut. A fine feed can usually be used, making it possible to run a high surface speed. A 50 percent increase in speed over the roughing speed is commonly used. In particular cases, the finishing speed may be twice the roughing

speed. In any event, run the work as fast as the tool will withstand to obtain the maximum speed in this operation. Use a sharp tool to finish turning.

## COOLANTS

A coolant serves two main purposes: (1) It cools the tool by absorbing a portion of the heat and reduces the friction between the tool and the metal being cut. (2) It keeps the cutting edge of the tool flushed clean. A coolant generally allows you to use a higher cutting speed, heavier feeds, and depths of cut than if you performed the machining operation dry. The life of the cutting tool is also prolonged by coolants. The most common coolants used are soluble oil and synthetic coolants. Refer to the manufacturers' recommendations for proper mixing rates.

The various operations used and materials machined on a lathe may cause problems in the selection of the proper coolant. A possible solution is to select a coolant that is suitable for the majority of the materials you plan to work with.

## CHATTER

A symptom of improper lathe operation is known as "chatter." Chatter is vibration in either the tool or the work. The finished work surface will appear to have a grooved or lined finish instead of the smooth surface that is expected. The vibration is set up by a weakness in the work, work support, tool, or tool support and is perhaps the most elusive thing you will find in the entire field of machine work. As a general rule, strengthening the various parts of the tool support train will help. It is also advisable to support the work with a center rest or follower rest.

Begin your search for the cause of the chatter by making sure that the surface speed is not excessive. Since excessive speed is probably the most frequent cause of chatter, reduce the speed and see if the chatter stops. You may also increase the feed, particularly if you are taking a rough cut and the finish is not important. Another adjustment you can try is to reduce the lead angle of the tool (the angle formed between the surface of the work and the side cutting edge of the tool). You may do this by positioning the tool closer and perpendicular to the work.

If none of these actions work, examine the lathe and its adjustments. Gibs may be loose or bearings may be worn after a long period of heavy service. If the machine is in perfect condition, the fault may be in

the tool or the tool setup. Check to be sure the tool has been properly sharpened to a point or as near to a point as the specific finish will permit. Reduce the overhang of the tool as much as possible and recheck the gib and bearing adjustments. Finally, be sure that the work is properly supported and that the cutting speed is not too high.

## FACING

Facing is the machining of the end surfaces and shoulders of a workpiece. In addition to squaring the ends of the work, facing will let you accurately cut the work to length. Generally, in facing the workpiece you will need to take only light cuts since the work has already been cut to approximate length or rough machined to the shoulder.

Figure 6-60 shows how to face a cylindrical piece. Place the work on centers and install a dog. Using a right-hand side tool, take one or two light cuts from the center outward to true the work.

If both ends of the work must be faced, reverse the piece so the dog drives the end just faced. Use a steel ruler to lay out the required length, measuring from the faced end to the end to be faced. After you ensure that there is no burr on the finished end to cause an inaccurate measurement, mark off the desired dimension with a scribe and face the second end.

Figure 6-61 shows the facing of a shoulder having a fillet corner. First, take a finish cut on the outside of the smaller diameter section. Next, machine the fillet with a light cut by manipulating the apron handwheel and the cross-feed handle in unison to produce a

smooth rounded surface. Finally, use the tool to face from the fillet to the outside diameter of the work.

In facing large surfaces, lock the carriage in position since only cross feed is required to traverse the tool across the work. With the compound rest set at 90° (parallel to the axis of the lathe), use the micrometer collar to feed the tool to the proper depth of cut in the face. For greater accuracy in getting a given size when finishing a face, set the compound rest at 30°. In this position, 0.001-inch movement of the compound rest will move the tool exactly 0.0005-inch in a direction parallel to the axis of the lathe. (In a 30° - 60° right triangle, the length of the side opposite the 30° angle is equal to one-half of the length of the hypotenuse.)

## TURNING

Turning is the machining of excess stock from the periphery of the workpiece to reduce the diameter. Bear in mind that the diameter of the work being turned is reduced by the amount equal to twice the depth of the cut; thus, to reduce the diameter of a piece by 1/4 inch, you must remove 1/8 inch of metal from the surface.

To remove large amounts of stock in most lathe machining, you will take a series of roughing cuts to remove most of the excess stock and then a finishing cut to accurately “size” the workpiece.

Deleted—No permission  
granted for electronic copy.

Figure 6-60.—Right-hand side tool.

Deleted—No permission  
granted for electronic copy.

Figure 6-61.—Facing a shoulder.

Deleted—No permission  
granted for electronic copy.

Figure 6-62.—Rough turning.

## Rough Turning

Figure 6-62 illustrates a lathe taking a heavy cut. This is called rough turning. When a great deal of stock is to be removed, you should take heavy cuts in order to complete the job in the least possible time.

Be sure to select the proper tool for taking a heavy chip. The speed of the work and the amount of feed of the tool should be as great as the tool will stand.

When taking a roughing cut on steel, cast iron, or any other metal that has a scale on its surface, be sure to set the tool deeply enough to get under the scale in the first cut. If you do not, the scale on the metal will dull the point of the tool.

Rough machine the work to almost the finished size; then be very careful in taking measurements on the rough surface.

Often the heat produced during rough turning will expand the workpiece, and the lubricant will flow out of the live center hole. This will result in both the center and the center hole becoming worn. Always check the center carefully and adjust as needed during rough turning operations. If you are using a ball bearing center, feel the area where the bearings are located and ensure the center is not too warm.

Figure 6-63 shows the position of the tool for taking a heavy chip on large work. Set the tool so that if anything causes it to change position during the

machining operation, the tool will move away from the work, thus preventing damage to the work. Also, setting the tool in this position may prevent chatter.

## Finish Turning

When you have rough turned the work to within about 1/32 inch of the finished size, take a finishing cut. A fine feed, the proper coolant and a keen-edged tool are necessary to produce a smooth finish. Measure carefully to be sure you are machining the work to the proper dimension. Stop the lathe whenever you take any measurements.

If you must finish the work to extremely close tolerances, wait until the piece is cool before taking the finish cut. If the piece has expanded slightly because of the heat generated by turning and you turn it to size while it is hot, the piece will be undersize after it has cooled and contracted.

If you plan to finish the work on a cylindrical grinder, leave the stock slightly oversize to allow for the metal the grinder will remove.

Perhaps the most difficult operation for a beginner in machine work is taking accurate measurements. So much depends on the accuracy of the work that you should make every effort to become proficient in using measuring instruments. You will develop a certain “feel” through experience. Do not be discouraged if your first efforts do not produce perfect results. Practice taking measurements on pieces of known dimensions. You will acquire the skill if you are persistent.

## Turning to a Shoulder

A time-saving procedure for machining a shoulder is illustrated in figure 6-64. First, locate and

Deleted—No permission  
granted for electronic copy.

Figure 6-63.—Position of tool for heavy cut.



Deleted—No permission granted for electronic copy.

Figure 6-64.—Machining to a shoulder.

scribe the exact location of the shoulder on the work. Next, use a parting tool to machine a groove  $1/32$  inch from the scribe line toward the smaller finish diameter end and  $1/32$  inch larger than the smaller finish diameter. Then, take heavy cuts up to the shoulder made by the parting tool. Finally, take a finish cut from the small end to the should scribe line. This procedure eliminates detailed measuring and speeds up production.

## PARTING AND GROOVING

One of the methods of cutting off a piece of stock while it is held in a lathe is a process called parting. This process uses a specially shaped tool with a cutting edge similar to that of a square nose tool. The parting tool is fed into the rotating work, perpendicular to its axis, cutting a progressively deeper groove as the work rotates. When the cutting edge of the tool gets to the center of the work being parted, the work drops off as if it were sawed off. Parting is used to cut off parts that have already been machined in the lathe or to cut tubing and bar stock to required lengths.

Parting tools can be the inserted blade type or can be ground from a standard tool blank. They may also be brazed on carbide or carbide inserts. Figure 6-65 shows two basic types of parting tools. For the tool to have maximum strength, the length of the cutting portion of the blade that extends from the holder should be only slightly greater than half the diameter of the work to be parted. The end cutting edge of the tool must feed directly toward the center of the workpiece. To ensure this, place a center in the tailstock and align the parting tool vertically with the tip of the center. The chuck should hold the work to

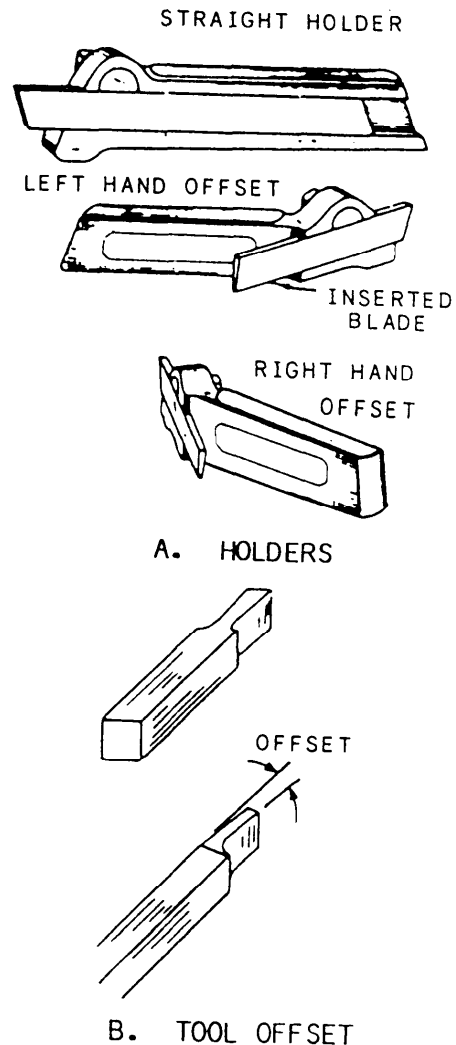


Figure 6-65.—Parting tools.

be parted with the point at which the parting is to occur as close as possible to the chuck jaws. Always make the parting cut at a right angle to the centerline of the work. Feed the tool into the revolving work with the cross-slide until the tool completely separates the work.

Cutting speeds for parting are usually slower than turning speeds. You should use a feed that will keep a thin chip coming from the work. If chatter occurs, decrease the speed and increase the feed slightly. If the tool tends to gouge or dig in, decrease the feed.

Grooves are machined in shafts to provide for tool runout in threading to a shoulder, to allow clearance for assembly of parts, to provide lubricating channels, or to provide a seating surface for seals and O-rings.

Square, round, and “V” grooves and the tools that are used to produce them are shown in figure 6-66.

The grooving tool is a type of forming tool. It is ground without side rake or back rake and is set to the work at center height with a minimum of overhang. The side and end relief angles are generally somewhat less than for turning tools. When you machine a groove, reduce the spindle speed to prevent the chatter that often develops at high speeds because of the greater amount of tool contact with the work.

## DRILLING AND REAMING

Drilling operations performed in a lathe differ very little from drilling operations performed in a drilling machine. For best results, start the drilling operation by drilling a center hole in the work, using a combination center drill and countersink. The combination countersink-center drill is held in a drill chuck that is mounted in the tailstock spindle. After you have center drilled the work, replace the drill chuck with a taper shank drill. (**NOTE: BEFORE** you insert any tool into the tailstock spindle, inspect the shank of the tool for burrs. If the shank is burred, remove the burrs with a handstone.) Feed the drill into the work by using the tailstock handwheel. Use a coolant/lubricant whenever possible and maintain sufficient pressure on the drill to prevent chatter, but not enough to overheat the drill.

If the hole is quite long, back the drill out occasionally to clear the flutes of metal chips. Large diameter holes may require you to drill a pilot hole first. This is done with a drill that is smaller than the finished diameter of the hole. After you have drilled the pilot hole to the proper depth, enlarge the hole with the finish drill. If you plan to drill the hole completely through the work, slow down the feed as the drill nears the hole exit. This will produce a smoother exit hole by causing the drill to take a finer cut as it exits the hole.

If the twist drill is not ground correctly, the drilled hole will be either excessively oversized or out of round. Check the drill for the correct angle, clearance, cutting edge lengths and straightness before setting it up for drilling. It is almost impossible to drill a hole exactly the same size as the drill regardless of the care taken in ensuring an accurately ground drill and the proper selection of speeds and feeds. For this reason, any job that requires close tolerances or a good finish on the hole should be reamed or bored to the correct size.

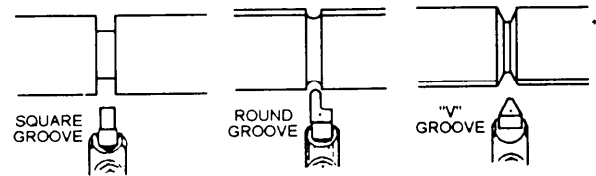


Figure 6-66.—Three common types of grooves.

If the job requires that the hole be reamed, it is good practice to first take a cleanup cut through the hole with a boring tool. This will true up the hole for the reaming operation. Be sure to leave about 1/64 inch for reaming. The machine reamer has a taper shank and is held in and fed by the tailstock. To avoid overheating the reamer, set the work speed at about half that used for the drilling operation. During the reaming operation, keep the reamer well lubricated. This will keep the reamer cool and also flush the chips from the flutes. Do not feed the reamer too fast; it may tear the surface of the hole and ruin the work.

## BORING

Boring is the machining of holes or any interior cylindrical surface. The piece to be bored must have a drilled or core hole, and the hole must be large enough to insert the tool. The boring process merely enlarges the hole to the desired size or shape. The advantage of boring is that you get a perfectly true round hole.

Work to be bored may be held in a chuck, bolted to the faceplate, or bolted to the carriage. Long pieces must be supported at the free end of a center rest.

When the boring tool is fed into the hole in work being rotated on a chuck or faceplate, the process is called single point boring. It is the same as turning except that the cutting chip is taken from the inside. The cutting edge of the boring tool resembles that of a turning tool. Boring tools may be the solid forged type or the inserted cutter bit type.

When the work to be bored is clamped to the top of the carriage, a boring bar is held between centers and driven by a dog. The work is fed to the tool by the automatic longitudinal feed of the carriage. Three types of boring bars are shown in figure 6-67. Note the countersunk center holes at the ends to fit the lathe centers.

Part A of figure 6-67 shows a boring bar fitted with a fly cutter held by a headless setscrew. The

other setscrew, bearing on the end of the cutter, is for adjusting the cutter to the work.

Part B of figure 6-67 shows a boring bar fitted with a two-edge cutter held by a taper key. This is more of a finishing or sizing cutter, as it cuts on both sides and is used for production work.

The boring bar shown in part C of figure 6-67 is fitted with a cast iron head to adapt it for boring work of large diameter. The head is fitted with a fly cutter similar to the one shown in part A. The setscrew with the tapered point adjusts the cutter to the work.

Figure 6-68 shows a common type of boring bar holder and applications of the boring bar for boring and internal threading. When threading is to be done in a blind hole, it sometimes becomes necessary to undercut or relieve the bottom of the hole. This will enable mating parts to be screwed all the way to the shoulder and make the threading operation much easier to do.

## KNURLING

Knurling is the process of rolling or squeezing impressions into the work with hardened steel rollers that have teeth milled into their faces. Examples of the various knurling patterns are shown in figure 6-17. Knurling provides a gripping surface on the work; it is also used for decoration. Knurling increases the diameter of the workpiece slightly when

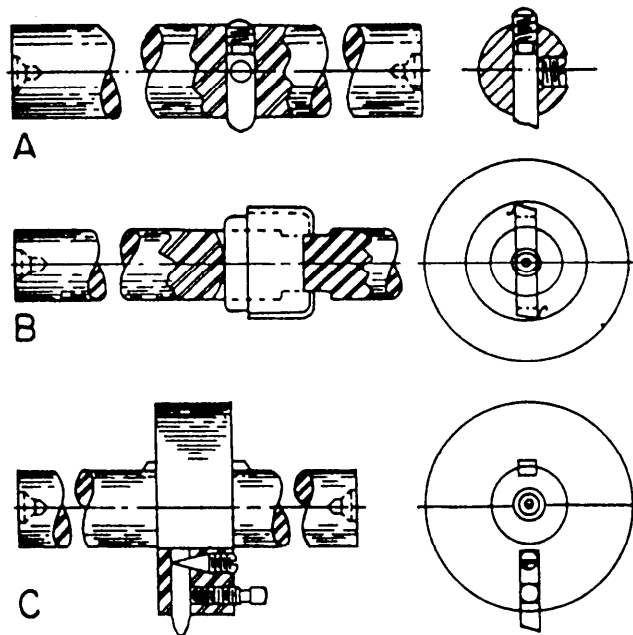
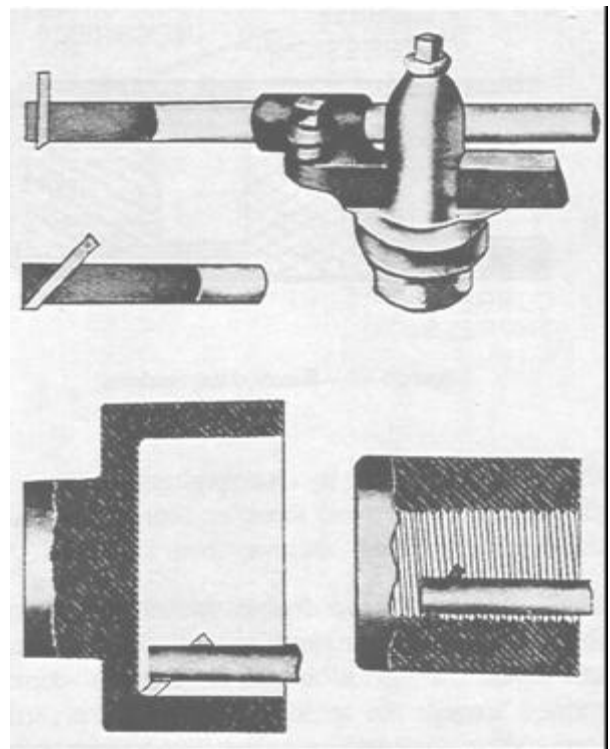


Figure 6-67.—Various boring bars.



28.135

Figure 6-68.—Application of boring bar holder.

the metal is raised by the forming action of the knurl rollers.

The knurling tool (fig. 6-16) is set up so the faces of the rollers are parallel to the surface of the work and with the upper and lower rollers equally spaced above and below the work axis or center line. The spindle speed should be about half the roughing speed for the type of metal being machined. The feed should be between 0.015 inch and 0.025 inch per revolution. The work should be rigidly mounted in the tailstock to help offset the pressure exerted by the knurling operation.

The actual knurling operation is simple if you follow a few basic rules. The first step is to make sure that the rollers in the knurling tool turn freely and are free of chips and imbedded metal between the cutting edges. During the knurling process, apply an ample supply of oil at the point of contact to flush away chips and provide lubrication. Position the carriage so that one-third to one-half of the face of the rollers extends beyond the end of the work. This eliminates part of the pressure required to start the knurl impression. Force the knurling rollers into contact with the work. Engage the spindle clutch. Check the knurl to see if the rollers have tracked properly, as

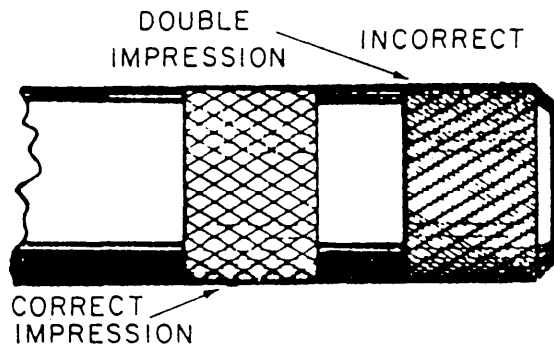


Figure 6-69.—Knurled impressions.

shown in figure 6-69, by disengaging the clutch after the work has revolved three or four times and by backing the knurling tool away from the work.

If the knurls have double tracked, as shown in figure 6-69, move the knurling tool to a new location and repeat the operation. If the knurl is correctly formed, engage the spindle clutch and the carriage feed. Move the knurling rollers into contact with the correctly formed knurled impressions. The rollers will align themselves with the impressions. Allow the knurling tool to feed to within about 1/32 inch of the end of the surface to be knurled. Disengage the carriage feed and with the work revolving, feed the carriage by hand to extend the knurl to the end of the surface. Force the knurling tool slightly deeper into the work, reverse the direction of feed and engage the carriage feed. Allow the knurling tool to feed until the opposite end of the knurled surface is reached. Never allow the knurls to feed off the surface.

Repeat the knurling operation until the diamond impressions converge to a point. Passes made after the correct shape is obtained will result in stripping away the points of the knurl. Clean the knurl with a brush and remove any burrs or sharp edges with a file. When knurling, do not let the work rotate while the

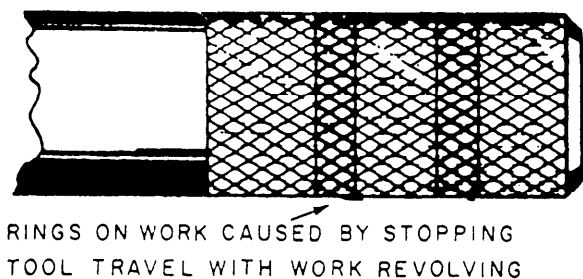


Figure 6-70.—Rings on a knurled surface.

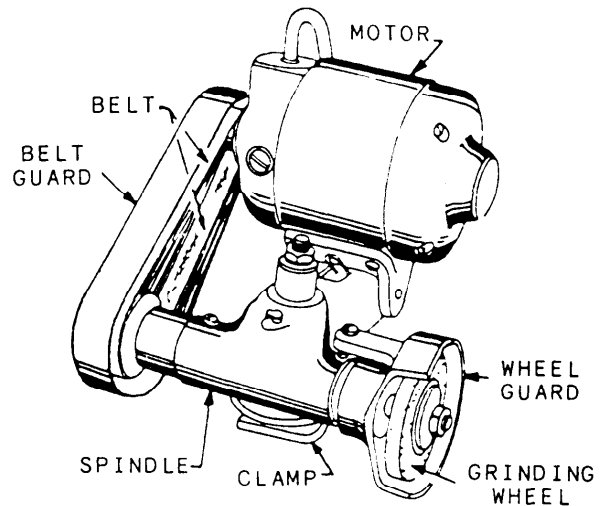


Figure 6-71.—Toolpost grinder.

tool is in contact with it if the feed is disengaged. This will cause rings to be formed on the surface, as shown in figure 6-70.

### SETTING UP THE TOOLPOST GRINDER

The toolpost grinder is a portable grinding machine that can be mounted on the compound rest of a lathe in place of the toolpost. It can be used to machine work that is too hard to cut by ordinary means or to machine work that requires a very fine finish. Figure 6-71 shows a typical toolpost grinder.

The grinder must be set on center, as shown in figure 6-72. The centering holes located on the spindle shaft are used for this purpose. The grinding wheel takes the place of a lathe cutting tool; it can perform most of the same operations as a cutting tool. Cylindrical, tapered, and internal surfaces can be ground with the toolpost grinder. Very small grinding

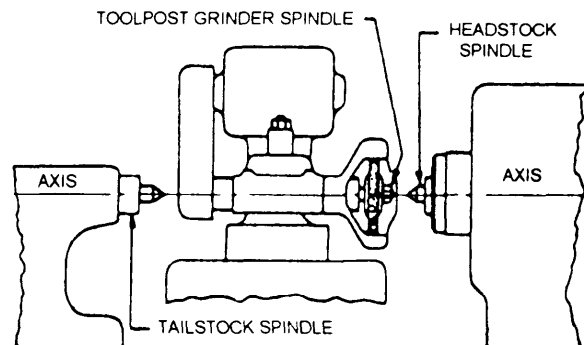


Figure 6-72.—Mounting the grinder at center height.

wheels are mounted on tapered shafts, known as quills, to grind internal surfaces.

The grinding wheel speed is changed by using various sizes of pulleys on the motor and spindle shafts. An instruction plate on the grinder gives both the diameter of the pulleys required to obtain a given speed and the maximum safe speed for grinding wheels of various diameters. Grinding wheels are safe for operation at a speed just below the highest recommended speed. A higher than recommended speed may cause the wheel to disintegrate. For this reason, wheel guards are furnished with the toolpost grinder to protect against injury.

Always check the pulley combinations given on the instruction plate of the grinder when you mount a wheel. Be sure that the combination is not reversed, because this may cause the wheel to run at a speed far in excess of that recommended. During all grinding operations, wear goggles to protect your eyes from flying abrasive material.

Before you use the grinder, dress and true the wheel with a diamond wheel dresser. The dresser is held in a holder that is clamped to the chuck or faceplate of the lathe. Set the point of the diamond at center height and at a  $10^{\circ}$  to  $15^{\circ}$  angle in the direction of the grinding wheel rotation, as shown in figure 6-73. The  $10^{\circ}$  to  $15^{\circ}$  angle prevents the diamond from gouging the wheel. Lock the lathe spindle by placing the spindle speed control lever in the low rpm position. (**NOTE:** The lathe spindle does not revolve when you are dressing the grinding wheel.)

Bring the grinding wheel into contact with the diamond dresser by carefully feeding the cross-slide in by hand. Move the wheel slowly by hand back and forth over the point of the diamond, taking a maximum cut of 0.0002 inch. Move the carriage if the face of the wheel is parallel to the ways of the lathe. Move the compound rest if the face of the wheel is at an angle. Make the final depth of cut of 0.0001 inch with a slow, even feed to obtain a good wheel finish. Remove the diamond dresser holder as soon as you finish dressing the wheel and adjust the grinder to begin the grinding operation.

Rotate the work at a fairly low speed during the grinding operation. The recommended surface speed is 60 to 100 fpm. The depth of cut depends upon the hardness of the work, the type of grinding wheel, and the desired finish. Avoid taking grinding cuts deeper than 0.002 inch until you gain experience. Use a fairly low rate of feed. You will soon be able to judge

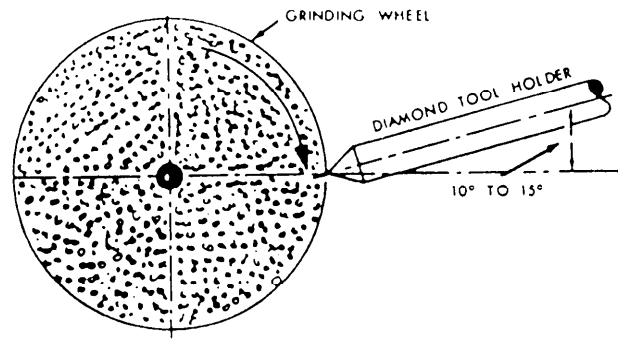
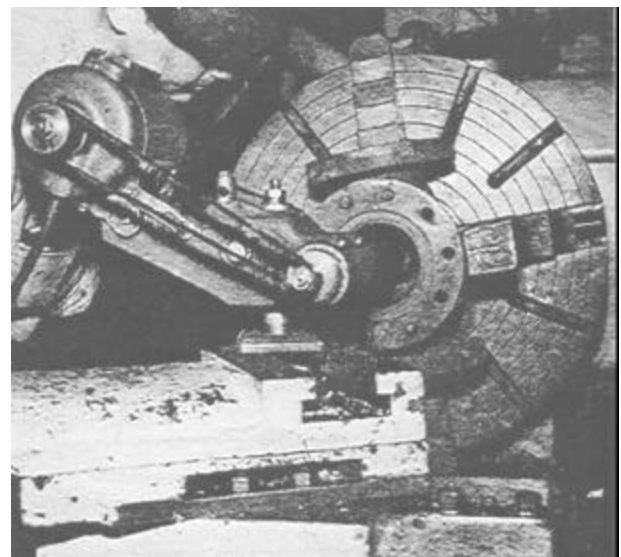


Figure 6-73.—Position of the diamond dresser.

whether the feed should be increased or decreased. Never stop the work or the grinding wheel while they are in contact with each other.

Figure 6-74 illustrates refacing the seat of a high-pressure steam valve that has a hard, Stellite-faced surface. The refacing must be done with a toolpost grinder. Be sure that all inside diameters run true before starting the machine work. Spindle speed of the lathe should be about 40 rpm or less. Too high a speed will cause the grinding wheel to vibrate. Set the compound rest to correspond with the valve seat angle. Use the cross-slide hand feed or the micrometer stop on the carriage for controlling the depth of cut; use the compound rest for traversing the grinding wheel across the work surface. Remember, whenever you grind on a lathe, always place a cloth across the ways of the bed and over any other



28.136  
Figure 6-74.—Refacing seat of high-pressure steam valve.

machined surfaces that could become contaminated from grinding dust.

## TAPERS

Taper is the gradual decrease in the diameter of thickness of a piece of work toward one end. To find the amount of taper in any given length of work, subtract the size of the small end from the size of the large end. Taper is usually expressed as the amount of taper per foot of length, or as an angle. The following examples explain how to determine taper per foot of length.

**EXAMPLE 1:** Find the taper per foot of a piece of work 2 inches long: Diameter of the small end is 1 inch; diameter of the large end is 2 inches.

The amount of the taper is 2 inches minus 1 inch, which equals 1 inch. The length of the taper is given as 2 inches. Therefore, the taper is 1 inch in 2 inches of length. In 12 inches of length it would be 6 inches. (See fig. 6-75).

**EXAMPLE 2:** Find the taper per foot of a piece 6 inches long. Diameter of the small end is 1 inch; diameter of the large end is 2 inches.

The amount of taper is the same as in example 1; that is, 1 inch. (See fig. 6-75.) However, the length of this taper is 6 inches; hence the taper per foot is  $1 \text{ inch} \times 12/6 = 2 \text{ inches per foot}$ .

From the foregoing, you can see that the length of a tapered piece is very important in computing the

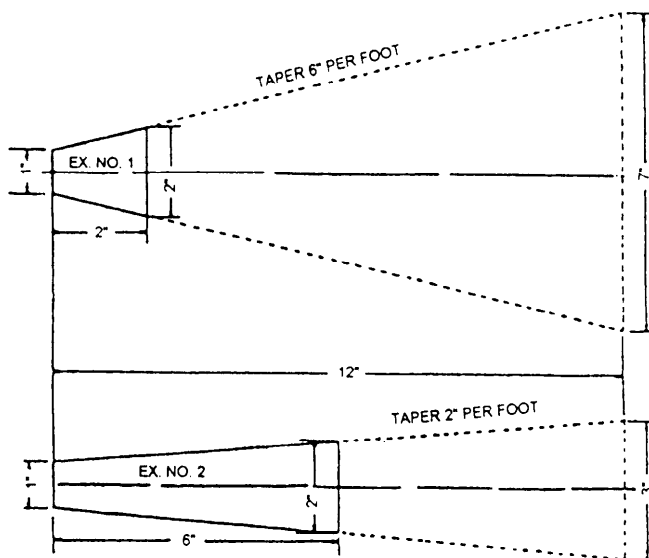


Figure 6-75.—Tapers.

taper. If you bear this in mind when machining tapers, you will not go wrong. Use the formula:

$$TPF = TPI \times 12$$

where:

$$TPF = \text{TAPER PER FOOT}$$

$$TPI = \text{TAPER PER INCH}$$

Other formulas used in figuring tapers are as follows:

$$TPI = \frac{T}{L}$$

where:

$$TPI = \text{TAPER PER INCH}$$

$$T = \text{TAPER (Difference between large and small diameters, expressed in inches)}$$

$$L = \text{LENGTH of taper, expressed in inches}$$

$$T = \frac{L \times TPF}{12} \text{ and } T = TPI \times L \text{ (in inches)}$$

$$TPI = \frac{TPF}{12}$$

Tapers are frequently cut by setting the angle of the taper on the appropriate lathe attachment. There are two angles associated with a taper—the included angle and the angle with the center line. The included angle is the angle between the two angled sides of the taper. The angle with the center line is the angle between the center line and either of the angled sides. Since the taper is turned about a center line, the angle between one side and the center line is always equal to the angle between the other side and the center line. Therefore, the included angle is always twice the angle with the center line. The importance of this relationship will be shown later in this chapter.

There are several well-known tapers that are used as standards for machines on which they are used. These standards make it possible to make or get parts to fit the machine in question without detailed measuring and fitting. By designating the name and number of the standard taper being used, you can immediately find the length, the diameter of the small and large ends, the taper per foot, and all other

pertinent measurements in appropriate tables found in the current edition of the *Machinery's Handbook*.

There are three standard tapers with which you should be familiar: (1) the **MORSE TAPER** (approximately 5/8 inch per foot) used for the tapered holes in lathe and drill press spindles and the attachments that fit them, such as lathe centers, drill shanks, and so on; (2) the **BROWN & SHARPE TAPER** (1/2 inch per foot, except No. 10, which is 0.5161 inch per foot) used for milling machine spindle shanks; and (3) the **JARNO TAPER** (0.600 inch per foot) used by some manufacturers because of the ease with which its dimensions can be determined:

$$\text{Diameter of large end} = \frac{\text{taper number}}{8}$$

$$\text{Diameter of small end} = \frac{\text{taper number}}{10}$$

$$\text{Length of taper} = \frac{\text{taper number}}{2}$$

Two additional tapers that are considered standard are the tapered pin and pipe thread tapers. Tapered pins have a taper of 1/4 inch per foot, while tapered pipe threads have a taper of 3/4 inch per foot.

### Methods of Turning Tapers

In ordinary straight turning, the cutting tool moves along a line parallel to the axis of the work, causing the finished job to be the same diameter throughout. If, however, in cutting, the tool moves at an angle to the axis of the work, a taper will be produced.

Therefore, to turn a taper, you must either mount the work in the lathe so the axis on which it turns is at an angle to the axis of the lathe, or cause the cutting tool to move at an angle to the axis of the lathe.

There are three methods in common use for turning tapers:

- **SET OVER THE TAILSTOCK**, which moves the dead center away from the axis of the lathe and causes work supported between centers to be at an angle with the axis of the lathe.
- **USE THE COMPOUND REST** set at an angle, which causes the cutting tool to be fed at the desired angle to the axis of the lathe.
- **USE THE TAPER ATTACHMENT**, which also causes the cutting tool to move at an angle to the axis of the lathe.

In the first method, the cutting tool is fed by the longitudinal feed parallel to the lathe axis, but a taper is produced because the work axis is at an angle. In the second and third methods, the work axis coincides with the lathe axis, but a taper is produced because the cutting tool moves at an angle.

**SETTING OVER the TAILSTOCK.**—As stated earlier in this chapter, you can move the tailstock top sideways on its base by using the adjusting screws. In straight turning you use these adjusting screws to align the dead center with the tail center by moving the tailstock to bring it on the center line of the spindle axis. For taper turning, you deliberately move the tailstock off center, and the amount you move it determines the taper produced. You can approximate the amount of setover by using the zero lines inscribed on the base and top of the tailstock as shown in figure 6-76. For final adjustment use a dial indicator to measure the distance you move the tailstock.

In turning a taper by this method, the distance between centers is of utmost importance. To illustrate, figure 6-77 shows two very different tapers

Deleted—No permission  
granted for electronic copy.

Deleted—No permission  
granted for electronic copy.

Figure 6-76.—Tailstock setover lines for taper turning.

Figure 6-77.—Setover of tailstock showing importance of considering length of work.

produced by the same amount of setover of the tailstock, because for one taper the length of the work between centers is greater than for the other. **THE CLOSER THE DEAD CENTER IS TO THE LIVE CENTER, THE STEEPER WILL BE THE TAPER PRODUCED.** Suppose you want to turn a taper on the full length of a piece 12 inches long with one end having a diameter of 3 inches, and the other end a diameter of 2 inches. The small end is to be 1 inch smaller than the large end; so you set the tailstock over one-half of this amount or 1/2 inch in this example. Thus, at one end the cutting tool will be 1/2 inch closer to the center of the work than at the other end; so the diameter of the finished job will be  $2 \times 1/2$  or 1 inch less at the small end. Since the piece is 12 inches long, you have produced a taper of 1 inch per foot. Now, if you wish to produce a taper of 1 inch per foot on a piece only 6 inches long, the small end will be only 1/2 inch less in diameter than the larger end, so you should set over the tailstock 1/4 inch or one-half of the distance used for the 12-inch length.

By now you can see that the setover is proportional to the length between centers. Setover is computed by using the following formula:

$$S = \frac{T}{2} \times \frac{L}{12}$$

where:

$S$  = setover in inches

$T$  = taper per foot in inches

$L$  = length of taper in inches

$\frac{L}{12}$  = length in feet of taper

Remember that  $L$  is the length of the work from the live center to the dead or ball bearing center. If the work is on a mandrel,  $L$  is the length of the mandrel between centers. You cannot use the setover tailstock method for steep tapers because the setover would be too great and the work would not be properly supported by the lathe centers. The bearing surface becomes less and less satisfactory as the setover is increased. Do not exceed 0.250-inch setover since your center hole and your tailstock center will not align properly.

After turning a taper by the tailstock setover method, do not forget to realign the centers for straight turning of your next job.

**USING the COMPOUND REST.** —The compound rest is generally used for short, steep tapers. Set it at the angle the taper will make with the center line (that is, half of the included angle of the taper). Then, feed the tool to the work at this angle by using the compound rest feed screw. The length of taper you can machine is short because the travel of the compound rest is limited.

One example of using the compound rest for taper work is the truing of a lathe center. Other examples are refacing an angle type valve disk and machining the face of a bevel gear. Such jobs are often referred to as working to an angle rather than as taper work.

The graduations marked on the compound rest provide a quick means for setting it to the angle desired. When the compound rest is set at zero, the cutting tool is perpendicular to the lathe axis. When the compound rest is set at 90° on either side of zero, the cutting tool is parallel to the lathe axis.

To set up the compound rest for taper turning, first determine the angle to be cut, measured from the center line. This angle is half of the included angle of the taper you plan to cut. Then, set the compound rest to the complement of the angle to be cut (90° minus the angle to be cut). For example, to machine a 50° included angle (25° angle with the center line), set the compound rest at 90°–25°, or 65°.

When you must set the compound rest very accurately, to a fraction of a degree for example, run the carriage up to the faceplate and set the compound rest with a vernier bevel protractor set to the required angle. Hold the blade of the protractor on the flat surface of the faceplate and hold the base of the protractor against the finished side of the compound rest.

**USING THE TAPER ATTACHMENT.**—For turning and boring long tapers with accuracy, the taper attachment is indispensable. It is especially useful in duplicating work; you can turn and bore identical tapers with one setting of the taper guide bar. Set the guide bar at an angle to the lathe that corresponds to the desired taper. The tool cross slide will be moved laterally by a shoe, which slides on the guide bar as the carriage moves longitudinally. The cutting tool will move along a line parallel to the guide bar. The taper produced will have the same angular measurement as that set on the guide bar. The



Deleted—No permission  
granted for electronic copy.

**Figure 6-78.—End view of taper guide bar.**

guide bar is graduated in degrees at one end and in inches per foot of taper at the other end to provide for rapid setting. Figure 6-78 is a view of the end that is graduated in inches per foot of taper.

When you prepare to use the taper attachment, run the carriage up to the approximate position of the work to be turned. Set the tool on line with the center of the lathe. Then, bolt or clamp the holding bracket to the ways of the bed (the attachment itself is bolted to the back of the carriage saddle) and tighten the clamp (C, fig. 6-79). The taper guide bar now controls the lateral movement of the cross slide. Set the guide bar for the taper desired; the attachment is ready for operation. To make the final adjustment of the tool for size, use the compound rest feed screw, since the cross-feed screw is inoperative.

There will be a certain amount of lost motion or backlash when the tool first starts to feed along the work. This is caused by looseness between the

Deleted—No permission  
granted for electronic copy.

**Figure 6-79.—Turning a taper using taper attachment.**

cross-feed screw and the cross-slide nut. If the backlash is not eliminated, a straight portion will be turned on the work. You can remove the backlash by moving the carriage and tool slightly past the start of the cut and then returning the carriage and tool to the start of the cut.

### Methods of Boring Tapers

Taper boring is usually done with either the compound rest or the taper attachment. The rules that apply to outside taper turning also apply to the boring of taper holes. Begin by drilling the hole to the correct depth with a drill of the same size as the specified small diameter of the taper. This gives you the advantage of boring to the right size without having to remove metal at the bottom of the bore, which is rather difficult, particularly in small, deep holes.

For turning and boring tapers, set the tool cutting edge exactly at the center of the work. That is, set the point of the cutting edge even with the height of the lathe centers; otherwise, the taper may be inaccurate.

Cut the hole and measure its size and taper using a taper plug gauge and the “cut and try” method.

1. After you have taken one or two cuts, clean the bore.
2. Rub the gauge lightly with chalk (or prussian blue if the taper must be highly accurate).
3. Insert the gauge into the hole and turn it SLIGHTLY so the chalk (or prussian blue) rubs from the gauge onto the surface of the hole. If the workpiece is to be mounted on a spindle, use the tapered end of the spindle instead of a gauge to test the taper.
4. Areas that do not touch the gauge will be shown by a lack of chalk (or prussian blue).
5. Continue making minor corrections until all, or an acceptable portion, of the hole’s surface touches the gauge. Be sure the taper diameter is correct before you turn the taper to its finish diameter.

Figure 6-80 shows a Morse standard taper plug and a taper socket gauge. They not only give the proper taper, but also show the proper distance that the taper should enter the spindle.

## SCREW THREADS

Much of the machine work performed by a Machinery Repairman includes the use of screw threads. The thread forms you will be working with most are V-form threads, Acme threads, and square threads. Each of these thread forms is used for specific purposes. V-form threads are commonly used on fastening devices, such as bolts and nuts, as well as on machine parts. Acme screw threads are generally used for transmitting motion, such as between the lead screw and lathe carriage. Square threads are used to increase mechanical advantage and to provide good clamping ability as in the screw jack or vise screw. Each of these screw forms is discussed more fully later in the chapter. We will also discuss cutting threads on an engine lathe.

There are several terms used in describing screw threads and screw thread systems that you must know before you can calculate and machine screw threads. Figure 6-81 illustrates some of the following terms:

**EXTERNAL THREAD:** A thread on the outside surface of a cylinder.

**INTERNAL THREAD:** A thread on the inside surface of a hollow cylinder.

**RIGHT-HAND THREAD:** A thread that, when viewed axially, winds in a clockwise and receding direction.

**LEFT-HAND THREAD:** A thread that, when viewed axially, winds in a counterclockwise and receding direction.

**LEAD:** The distance a threaded part moves axially in a fixed mating part in one complete revolution.

**PITCH:** The distance between corresponding points on adjacent threads.

Deleted—No permission  
granted for electronic copy.

Figure 6-80.—Morse taper socket gauge and plug gauge.

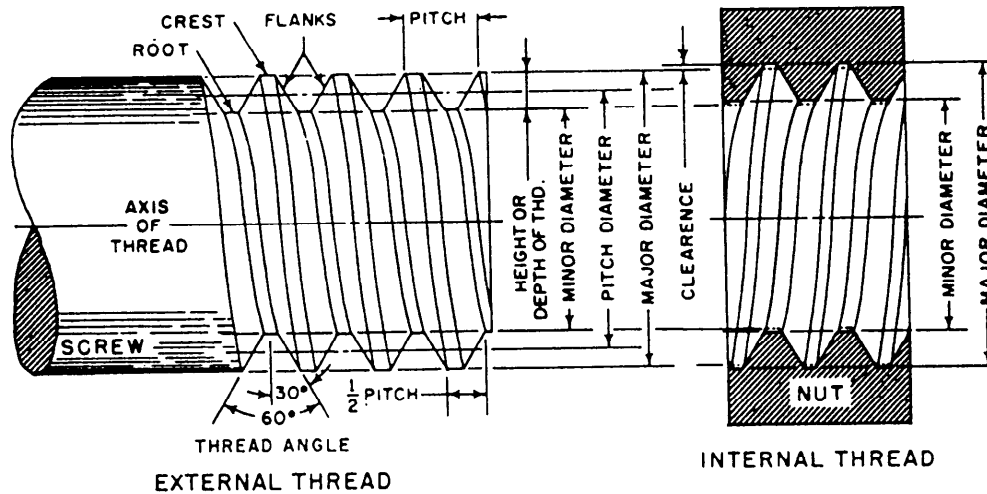


Figure 6-81.—Screw thread nomenclature.

**SINGLE THREAD:** A single (single start) thread whose lead equals the pitch.

**MULTIPLE THREAD:** A multiple (multiple start) thread whose lead equals the pitch multiplied by the number of starts.

**CLASS OF THREADS:** A group of threads designed for a certain type of fit. Classes of threads are distinguished from each other by the amount of tolerance and allowance specified.

**THREAD FORM:** The view of a thread along the thread axis for a length of one pitch.

**FLANK:** The side of the thread.

**CREST:** The top of the thread (bounded by the major diameter on external threads; by the minor diameter on internal threads).

**ROOT:** The bottom of the thread (bounded by the minor diameter on external threads; by the major diameter on internal threads).

**THREAD ANGLE:** The angle formed by adjacent flanks of a thread.

**PITCH DIAMETER:** The diameter of an imaginary cylinder that is concentric with the thread axis and whose periphery passes through the thread profile at the point where the widths of the thread and the thread groove are equal. The pitch diameter is the diameter that is measured when the thread is machined to size. A change in pitch diameter changes the fit between the thread being machined and the mating thread.

**NOMINAL SIZE:** The size that is used for identification. For example, the nominal size of a 1/2-20 thread is 1/2 inch, but its actual size is slightly smaller to provide clearance.

**ACTUAL SIZE:** The measured size.

**BASIC SIZE:** The theoretical size. The basic size is changed to provide the desired clearance or fit.

**MAJOR DIAMETER:** The diameter of an imaginary cylinder that passes through the crests of an external thread or the roots of an internal thread.

**MINOR DIAMETER:** The diameter of an imaginary cylinder that passes through the roots of an external thread or the crests of an internal thread.

**HEIGHT OF THREAD:** The distance from the crest to the root of a thread measured along a perpendicular to the axis of the threaded piece (also called straight depth of thread).

**SLANT DEPTH:** The distance from the crest to the root of a thread measured along the angle forming the side of the thread.

**ALLOWANCE:** An intentional difference between the maximum material limits of mating parts. It is the minimum clearance (positive allowance) or maximum interference (negative allowance) between such parts.

**TOLERANCE:** The total permissible variation of a size. The tolerance is the difference between the limits of size.

**THREAD FORM SERIES:** Threads are made in many different shapes, sizes, and accuracies.

When special threads are required by the product designer, he will specify in detail all the thread characteristics and their tolerances for production information. When a standard thread is selected, however, the designer needs only to specify size, number of threads per inch, designation of the standard series and class of fit. With these specifications, all other information necessary for production can be obtained from the established standard, as published. The abbreviated designations for the different series are as follows:

<u>Abbreviation</u>	<u>Full Title of Standard Series</u>
UNC	Unified coarse thread series
UNF	Unified fine thread series
UNEF	Unified extra fine thread series
NC	American National coarse thread series
NF	American National fine thread series
NEF	American National extra-fine thread series
UN	Unified constant pitch series including 4, 6, 8, 12, 16, 20, 28, and 32 threads per inch
NA	American National Acme thread series
NPT	American National tapered pipe thread series
NPS	American National straight pipe thread series
NH	American National hose coupling thread series
NS	American National form thread-special pitch
N BUTT	National buttress thread

**THREAD DESIGNATION:** A thread is designated by nominal size, number of threads per inch, series symbol, and class symbol, in that order. For example, the designation 1/4-20 UNC-3A specifies a thread with the following characteristics:

Nominal thread diameter = 1/4 inch

Number of threads per inch = 20

Series (unified coarse) = UNC

Class = 3

External thread = A

Unless the designation LH (left hand) follows the class designation, the thread is assumed to be a right-hand thread. An example of the designation for a left-hand thread is 1/4-20 UNC-3A-LH.

### V-FORM THREADS

The three forms of V-threads that you must know how to machine are the V-sharp, the American National and the American Standard unified. All of these threads have a 60° included angle between their sides. The V-sharp thread has a greater depth than the others and the crest and root of this thread have little or no flat. The external American Standard unified thread has slightly less depth than the external American National thread but is otherwise similar. The American Standard unified thread is actually a modification of the American National thread. This modification was made so that the unified series of threads, which permits interchangeability of standard threaded fastening devices manufactured in the United States, Canada, and the United Kingdom, could be included in the threading system used in the United States.

To cut a V-form screw thread, you need to know (1) the pitch of the thread, (2) the straight depth of the thread, (3) the slant depth of the thread, and (4) the width of the flat at the root of the thread. The pitch of a thread is the basis for calculating all other dimensions and is equal to 1 divided by the number of threads per inch. The tap drill size is equal to the thread size minus the pitch, or the thread size minus ONE divided by the number of threads per inch.

$$\text{Tap drill size} = \text{Thread size} - \frac{1}{n}$$

When you feed the thread cutting tool into the workpiece, use the slant depth to determine how far to feed the tool into the work. The point of the threading tool must have a flat equal to the width of the flat at the root of the thread (external or internal thread, as applicable). If the flat at the point of the tool is too wide, the resulting thread will be too thin. If the flat is too narrow, the thread will be too thick.

The following formulas will provide the information you need for cutting V-form threads:

1. V-sharp thread

$$\text{Pitch} = \frac{1}{n} \text{ or } 1 \div \text{number of threads per inch}$$

$$\text{Straight Depth of thread} = 0.866 \times \text{pitch}$$

2. American National Thread

$$\text{Pitch} = 1 \div \text{number of threads per inch}$$

$$\begin{aligned} \text{Straight depth of external thread} \\ = 0.64952 \times \text{pitch or } 0.64952p \end{aligned}$$

$$\begin{aligned} \text{Straight depth of internal thread} \\ = 0.541266 \times \text{pitch or } 0.541266p \end{aligned}$$

$$\begin{aligned} \text{Width of flat at point of tool for external and} \\ \text{internal threads} = 0.125 \times \text{pitch or } 0.125p \end{aligned}$$

$$\begin{aligned} \text{Slant depth of external thread} = 0.750 \\ \times \text{pitch or } 0.750p \end{aligned}$$

$$\begin{aligned} \text{Slant depth of internal thread} = 0.625 \\ \times \text{pitch or } 0.625p \end{aligned}$$

3. American Standard Unified

$$\begin{aligned} \text{Pitch} = 1 \div \text{number of threads per inch} \\ \text{or } \frac{1}{n} \end{aligned}$$

$$\begin{aligned} \text{Straight depth of external thread} = 0.61343 \\ \text{inch} \times \text{pitch or } 0.61343p \end{aligned}$$

$$\begin{aligned} \text{Straight depth of internal thread} = 0.54127 \\ \text{inch} \times \text{pitch or } 0.54127p \end{aligned}$$

$$\begin{aligned} \text{Width of flat at root of external thread} \\ = 0.125 \text{ inch} \times \text{pitch or } 0.125p \end{aligned}$$

$$\begin{aligned} \text{Width of flat at crest of external thread} \\ = 0.125 \text{ inch} \times \text{pitch or } 0.125p \end{aligned}$$

$$\begin{aligned} \text{Double height of external thread} = 1.22687 \\ \text{inch} \times \text{pitch or } 1.22687p \end{aligned}$$

$$\begin{aligned} \text{Double height of internal thread} = 1.08253 \\ \text{inch} \times \text{pitch or } 1.08253p \end{aligned}$$

$$\begin{aligned} \text{Slant depth of external thread} = 0.708 \\ \times \text{pitch or } 0.708p \end{aligned}$$

$$\begin{aligned} \text{Slant depth of internal thread} = 0.625 \\ \times \text{pitch or } 0.625p \end{aligned}$$

**NOTE:** MULTIPLYING the constant by the pitch, as in the preceding formulas, produces the same result as if you divide the constant by the number of threads per inch.

To produce the correct thread profile, you must use a tool accurately ground to the correct angle and contour. Also, you must set the cutting tool in the correct position. Figure 6-82 shows how a tool must be ground and set. Remember, if you are using a

Deleted—No permission granted for electronic copy.

Figure 6-82.—Threading tool setup for V-form threads.

Deleted—No permission granted for electronic copy.

Figure 6-83.—Acme thread and formulas for cutting.

quick-change toolholder you will not need to grind the top of the tool. If carbide inserts are being used, the thread form is already ground.

Grind the point of the tool to an angle of  $60^\circ$ , as shown in A of figure 6-82. Use a center gauge or a thread tool gauge for grinding the tool to the exact angle required. The top of the tool is usually ground flat, with no side rake or back rake. However, for cutting threads in steel, side rake is sometimes used.

Set the threading tool square with the work, as shown in B and C of figure 6-82. Use the center gauge to adjust the point of the threading tool; if you carefully set the tool, a perfect thread will result. If you do not set the threading tool perfectly square with the work, the angle of the thread will be incorrect.

For cutting external threads, place the top of the threading tool exactly on center as shown in D of figure 6-82. Note that the top of the tool is ground flat and is in exact alignment with the lathe center. This is necessary to obtain the correct angle of the thread.

The size of the threading tool for cutting an internal thread is important. The tool head must be small enough to be backed out of the thread and still leave enough clearance to be drawn from the threaded hole without injuring the thread. However, the boring bar that holds the threading tool for internal threading should be both as large as possible in diameter and as short as possible to keep it from springing away from the work during cutting.

## OTHER FORMS OF THREADS

In the following section, other forms of screw threads are illustrated with pertinent information on cutting these threads.

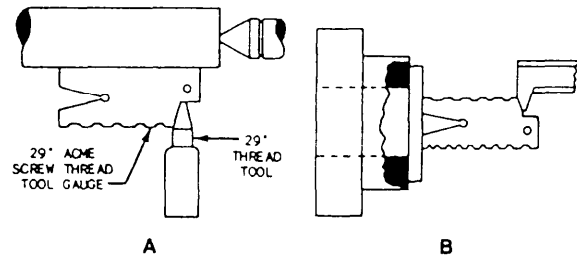


Figure 6-84.—Use of Acme thread tool gauge.

## The Acme Screw Thread

The Acme screw thread is used on valve stems, the lead screw of a lathe, and other places that require a strong thread. The top and bottom of the threads have an included angle of  $29^\circ$  (fig. 6-83).

Parts A and B of figure 6-84 show the method of setting an Acme threading tool for cutting an external and internal Acme thread, respectively. Note that a  $29^\circ$  Acme thread gauge is used in the same manner as the center gauge was used for V-form screw threads. Adjust the cutting edge of the tool to line it up exactly with the beveled edge of the gauge. The notches in the Acme thread gauge let you grind the squared front edge of the tool bit accurately according to the pitch of the thread to be machined.

In cutting an Acme thread, be sure the clearance is 0.010 inch between the top of the thread of the screw and the bottom of the thread of the nut in which it fits.

## The Square Thread

The square thread (fig. 6-85) is used when heavy threads are required, such as in jack screws, press screws, and feed screws. It is used for much the same

Deleted—No permission granted for electronic copy.

Figure 6-85.—Square thread and formulas.

purpose as the Acme thread, which is used in many places where the square thread was formerly used. The disadvantage of square threads is that the straight sides do not allow sideplay adjustment.

The cutting edge width of the tool for cutting square screw threads is exactly one-half the pitch, but the width of the edge of the tool for threading nuts is from 0.001 to 0.003 inch larger. This permits a sliding fit on the screw.

Set the threading tool for cutting square threads square with the work.

Be sure the clearance between the top of the screw thread and the bottom of the nut thread is about 0.005 to 0.008 inch for each inch of thread diameter.

### Buttress Thread

On a buttress thread (fig. 6-86) the load resisting side is nearly perpendicular to the thread axis and is called the pressure flank. The American Standard form of the buttress thread has a 7° angle on the pressure flank; other forms have 0°, 3°, or 5°. However, the American Standard form is most often used, and the formulas in this section apply to this form. The buttress thread can be designed to either push or pull against the internal thread of the mating part into which it is screwed. The direction of the thrust will determine the way you grind your tool for machining the thread. An example of the designation symbols for an American Standard buttress thread form is as follows:

6 - 10 (←N BUTT-2)

where

6 = basic major diameter of 6.000 inches

10 = 10 threads per inch

(← = internal member to push against external member)

N BUTT = National Buttress Form

2 = class of fit

**NOTE:** A symbol such as “←(” indicates that the internal member is to pull against the external member.

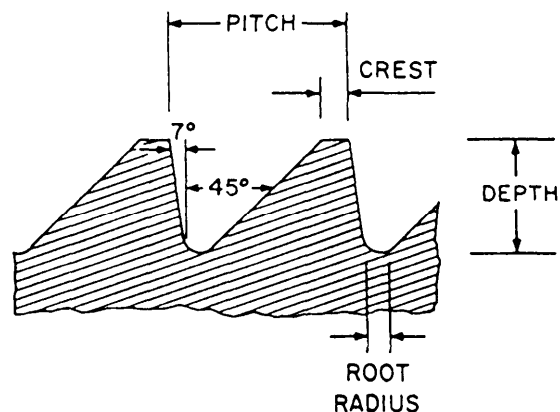


Figure 6-86.—Buttress thread.

The formulas for the basic dimensions of the American Standard buttress external thread are as follows:

$$\text{Pitch} = \frac{1}{n}$$

$$\text{Width of flat at crest} = 0.1631 \times \text{pitch}$$

$$\text{Root radius} = 0.0714 \times \text{pitch}$$

$$\text{Depth of thread} = 0.6627 \times \text{pitch}$$

The classes of fit are 1 = free, 2 = medium, 3 = close. The specific dimensions involved concern the tolerance of the pitch diameter and the major diameter and vary according to the nominal or basic size. Consult a handbook for specific information on the dimensions for the various classes of fit.

### Pipe Threads

American National Standard pipe threads are similar to the unified threads in that both have an included angle of 60° and a flat on the crest and the root of the thread. Pipe threads can be either tapered or straight, depending on the intended use of the threaded part. A description of the two types is given in the following paragraphs.

Tapered pipe threads are used to provide a pressure-tight joint when the internal and external mating parts are assembled correctly. Depending on the closeness of the fit of the mating parts, you may need to use a sealing tape or a sealer (pipe compound) to prevent leakage at the joint. The taper of the threads is 3/4 inch per foot. Machine and thread the section of pipe at this angle. The hole for the internal threads should be slightly larger than the minor diameter of the small end of the externally threaded part.

An example of a pipe thread is shown here.

*NPT 1/4-18*

where

*NPT = tapered pipe thread*

*1/4 = inside diameter of the pipe in inches*

*18 = threads per inch*

Figure 6-87 shows the typical taper pipe thread.

Straight pipe threads are similar in form to tapered pipe threads except that they are not tapered. The same nominal outside diameter and thread dimensions apply. Straight pipe threads are used for joining components mechanically and are not satisfactory for high-pressure applications. Sometimes a straight pipe thread is used with a tapered pipe thread to form a low-pressure seal in a vibration-free environment.

## CLASSES OF THREADS

Classes of fit for threads are determined by the amount of tolerance and allowance allowed for each particular class. The tolerance (amount that a thread may vary from the basic dimension) decreases as the class number increases. For example, a class 1 thread has more tolerance than a class 3 thread. The pitch diameter of the thread is the most important thread element in controlling the class of fit. The major diameter for an external thread and the minor diameter or bore size for an internal thread are also important, however, since they control the crest and root clearances more than the actual fit of the thread. A brief description of the different classes of fit follows:

- **Classes 1A and 1B:** Class 1A (external) and class 1B (internal) threads are used where quick and easy assembly is necessary and where a liberal allowance is required to permit ready assembly, even with slightly bruised or dirty threads.

- **Classes 2A and 2B:** Class 2A (external) and class 2B (internal) threads are the most commonly used threads for general applications, including production of bolts, screws, nuts, and similar threaded fasteners.

- **Classes 3A and 3B:** Class 3A (external) and class 3B (internal) threads are used where closeness of fit and accuracy of lead and angle of thread are

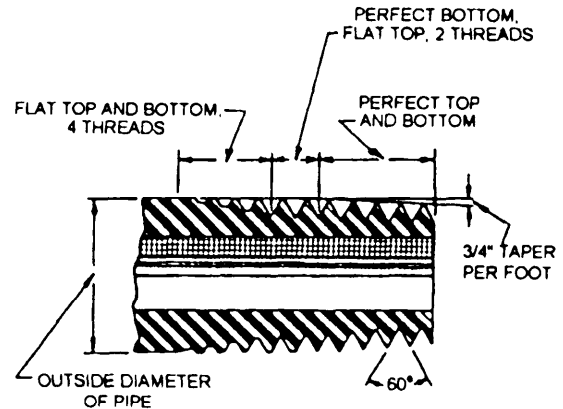


Figure 6-87.—Typical taper pipe thread.

important. These threads require consistency that is available only through high quality production methods combined with a very efficient system of gauging and inspection.

- **Class 5:** Class 5 threads are interference-fit threads in which the external threaded member is larger than the internally threaded member when both members are in the free state and which, when assembled, become the same size and develop a holding torque through elastic compression, plastic movement of the material, or both. There are a number of different thread designations within class 5. They distinguish between external and internal threads and the types of material the external thread will be driven into. This information may be found in the interference-fit threads section of *Machinery's Handbook*.

## MEASURING SCREW THREADS

Thread measurement is needed to ensure that the thread and its mating part will fit properly. It is important that you know the various measuring methods and the calculations that are used to determine the dimensions of threads.

The use of a mating part to estimate and check the needed thread is common practice when average accuracy is required. The thread is simply machined until the thread and the mating part will assemble. A snug fit is usually desired with very little, if any, play between the parts.

You will sometimes be required to machine threads that need a specific class of fit, or you may not have the mating part to use as a gauge. In these cases, you must measure the thread to make sure you get the required fit.



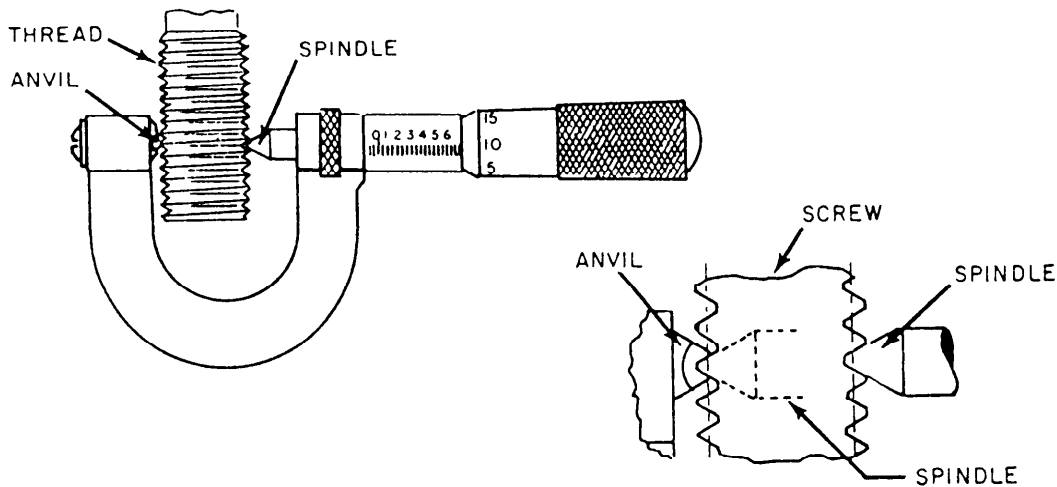


Figure 6-88.—Measuring threads with a thread micrometer.

An explanation of the various methods normally available to you is given in the following paragraphs.

Thread micrometers are used to measure the pitch diameter of threads. They are graduated and read in the same manner as ordinary micrometers. However, the anvil and spindle are ground to the shape of a thread, as shown in figure 6-88. Thread micrometers

come in the same size ranges as ordinary micrometers: 0 to 1 inch, 1 to 2 inches, and so on. In addition, they are available in various pitch ranges. The number of threads per inch must be within the pitch range of the thread.

Go and no-go gauges, such as those shown in figure 6-89, are often used to check threaded parts. The thread should fit the “go” portion of the gauge, but should not screw into or onto the “no-go” portion. Ring and plug gauges are available for the various sizes and classes of fit of thread. They are probably the most accurate method of checking threads because they envelop the total thread form, and in effect, check not only the pitch diameter and the major and minor diameters, but also the lead of the thread.

The pitch diameter of a thread can be accurately measured by an ordinary micrometer and three wires, as shown in figure 6-90.

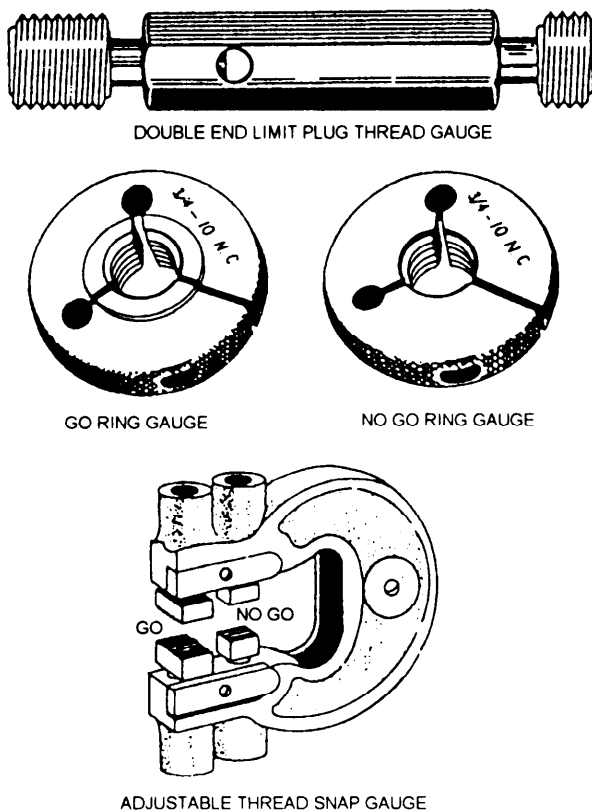


Figure 6-89.—Thread gauges.

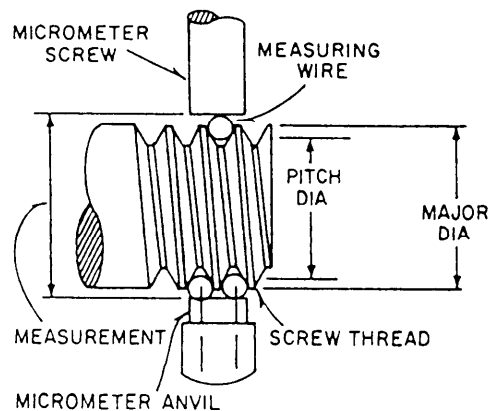


Figure 6-90.—Measuring threads using three wires.

The wire size you should use to measure the pitch diameter depends on the number of threads per inch. You will obtain the most accurate results when you use the **best wire size**. The best size is not always available, but you will get satisfactory results if you use wire diameters within a given range. Use a wire size as close as possible to the best wire size. To determine the wire sizes, use these formulas:

$$\text{Best wire size} = 0.57735 \text{ inch} \times \text{pitch}$$

$$\text{Smallest wire size} = 0.56 \text{ inch} \times \text{pitch}$$

$$\text{Largest wire size} = 0.90 \text{ inch} \times \text{pitch}$$

For example, the diameter of the best wire for measuring a thread that has 10 threads per inch is 0.0577 inch, but you could use any size between 0.056 inch and 0.090 inch.

**NOTE:** The wires should be fairly hard and uniform in diameter. All three wires must be the same size. You can use the shanks of drill bits as substitutes for the wires.

Use the following formulas to determine what the measurement over the wires should be for a given pitch diameter.

$$\text{Measurement} = \text{pitch diameter} - (0.86603 \times \text{pitch}) + (3 \times \text{wire diameter})$$

$$M = PD - (0.86603 \times xP) + (3 \times W)$$

Use the actual size of the wires in the formula, not the calculated size.

Example: What should the measurement be over the wires for a 3/4-10 UNC-2A thread? First, determine the required pitch diameter for a class 2A 3/4-10 UNC thread. You can find this information in charts in several handbooks for machinists. The limits of the pitch diameter for this particular thread size and class are between 0.6832 and 0.6773 inch. Use the maximum size (0.6832 inch) for this example. Next, calculate the pitch for 10 threads per inch. The formula, “one divided by the number of threads per inch”, will give you pitch =  $\frac{1}{n}$ . For 10 TPI, the pitch is 0.100 inch. As previously stated, the best wire size for measuring 10 TPI is 0.0577 inch, so assume that

you have this wire size available. Now make the calculation. The data collected so far are:

$$\text{Thread} = 3/4\text{-}10 \text{ UNC} - 2A$$

$$\text{Pitch diameter (PD)} = 0.6832 \text{ in.}$$

$$\text{Pitch (P)} = 0.100 \text{ in.}$$

$$\text{Wire size (W)} = 0.0577 \text{ in.}$$

The standard formula for the measurement over the wires was  $M = PD - (0.86603 \times P) + (3 \times W)$ . Enter the collected data in the correct positions of the formula:

$$M = 0.6832 \text{ in.} - (0.86603 \text{ in} \times 0.100 \text{ in.}) + (3 \times 0.0577 \text{ in.})$$

$$M = 0.6832 \text{ in.} - 0.086603 \text{ in.} + 0.1731 \text{ in.}$$

$$M = 0.769697 \text{ in.}$$

The measurement over the wires should be 0.769697 in. or when rounded to four decimal places, 0.7697 in.

As mentioned in the beginning of the section on classes of threads, the major diameter is a factor also considered in each different class of fit. The basic or nominal major diameter is seldom the size actually machined on the outside diameter of the part to be threaded. The actual size is smaller than the basic size. In the case of the 3/4 - 10 UNC - 2A thread, the basic size is 0.750 in.; however, the size that the outside diameter should be machined to is between 0.7482 and 0.7353 in.

## CUTTING SCREW THREADS ON THE LATHE

Screw threads are cut on the lathe by connecting the headstock spindle of the lathe with the lead screw through a series of gears to get a positive carriage feed. The lead screw is driven at the required speed in relation to the headstock spindle speed. You can arrange the gearing between the headstock spindle and lead screw so that you can cut any desired pitch. For example, if the lead screw has 8 threads per inch and you arrange the gears so the headstock spindle revolves four times while the lead screw revolves once, the thread you cut will be four times as fine as the thread on the lead screw, or 32 threads per inch. With the quick-change gear box, you can quickly and easily make the proper gearing arrangement by

Deleted—No permission  
granted for electronic copy.

**Figure 6-91.—Compound rest set at  $29\ 1/2^\circ$ .**

placing the levers as indicated on the index plate for the thread desired.

When you have the lathe set up to control the carriage movement for cutting the desired thread pitch, your next consideration is shaping the thread. Grind the cutting tool to the shape required for the form of the thread to be cut, that is-V-form, Acme, square, and so on.

### **Mounting Work in the Lathe**

When you mount work between lathe centers for cutting screw threads, be sure the lathe dog is securely attached before you start to cut the thread. If the dog should slip, the thread will be ruined. Do not remove the lathe dog from the work until you have completed the thread. If you must remove the work from the lathe before the thread is completed, be sure to replace the lathe dog in the same slot of the driving plate.

When you thread work in the lathe chuck, be sure the chuck jaws are tight and the work is well supported. Never remove the work from the chuck until the thread is finished.

When you thread long slender shafts, use a follower rest. You must use the center rest to support one end of long work that is to be threaded on the inside.

### **Position of Compound Rest for Cutting Screw Threads**

Ordinarily on threads of fine lead, you feed the tool straight into the work in successive cuts. For coarse threads, it is better to set the compound rest at one-half of the included angle of the thread and feed in along the side of the thread. For the last few finishing cuts, you should feed the tool straight in with the cross-feed of the lathe to make a smooth, even finish on both sides of the thread.

In cutting V-form threads and when maximum production is desired, it is customary to place the compound rest of the lathe at an angle of  $29\ 1/2^\circ$ , as shown in part A of figure 6-91. When you set the compound rest in this position and use the compound rest screw to adjust the depth of cut, you remove most of the metal by using the left side of the threading tool (B of fig. 6-91). This permits the chip to curl out of the way better than if you feed the tool straight in, and keeps the thread from tearing. Since the angle on the side of the threading tool is  $30^\circ$ , the right side of the tool will shave the thread smooth and produce a better finish; although it does not remove enough metal to interfere with the main chip, which is taken by the left side of the tool.

## Using the Thread-Cutting Stop

Because of the lost motion caused by the play necessary for smooth operation of the change gears, lead screw, half-nuts, and so forth, you must withdraw the thread-cutting tool quickly at the end of each cut. If you do not withdraw the tool quickly, the point of the tool will dig into the thread and may break off.

To reset the tool accurately for each successive cut and to regulate the depth of the chip, use the thread-cutting stop.

First, set the point of the tool so that it just touches the work, then lock the thread-cutting stop by turning the thread-cutting stop screw (A of fig. 6-92) until the shoulder is tight against the stop (B of fig. 6-92). When you are ready to take the first cut, run the tool rest back by turning the cross-feed screw to the left several times, and move the tool to the point where the thread is to start. Then, turn the cross-feed screw to the right until the thread-cutting stop screw strikes the thread-cutting stop. The tool is now in the original position. By turning the compound rest feed screw in 0.002 inch or 0.003 inch, you will have the tool in a position to take the first cut.

For each successive cut after returning the carriage to its starting point, you can reset the tool accurately to its previous position. Turn the cross-feed screw to the right until the shoulder of the screw (A) strikes the stop (B). Then, you can regulate the depth of the next cut by adjusting the compound rest feed screw as it was for the first chip.

Be sure to use a coolant or lubricant while cutting the threads. This will help to cool the work and to wash the chips away.

For cutting an internal thread, set the adjustable thread-cutting stop with the head of the adjusting screw on the inside of the stop. Withdraw the tool by moving it toward the center or axis of the lathe.

You can use the micrometer collar on the cross-feed screw in place of the thread-cutting stop, if you desire. To do this, first bring the point of the threading tool up so that it just touches the work; then adjust the micrometer collar on the cross-feed screw to zero. Make all adjustments for obtaining the desired depth of cut with the compound rest screw. Withdraw the tool at the end of each cut by turning the cross-feed screw to the right one turn, stopping at zero. You can then adjust the compound rest feed screw for any desired depth.

Deleted—No permission  
granted for electronic copy.

**Figure 6-92.—Adjustable thread-cutting stop mounted on carriage saddle (clamped to dovetail).**

## Engaging the Thread Feed Mechanism

When cutting threads on a lathe, clamp the half-nuts over the lead screw to engage the threading feed and release the half-nut lever at the end of the cut by means of the threading lever. Use the threading dial to determine when to engage the half-nuts so the cutting tool will follow the same path during each cut. When an index mark on the threading dial aligns with the witness mark on its housing, engage the half-nuts. For some thread pitches you can engage the half-nuts only when certain index marks are aligned with the witness mark. On most lathes you can engage the half-nuts as follows:

- For all even-numbered threads per inch, close the half-nuts at any line on the dial.
- For all odd-numbered threads per inch, close the half-nuts at any numbered line on the dial.
- For all threads involving one-half of a thread in each inch, such as 11 1/2, close the half-nuts at any odd-numbered line.

## Cutting the Thread

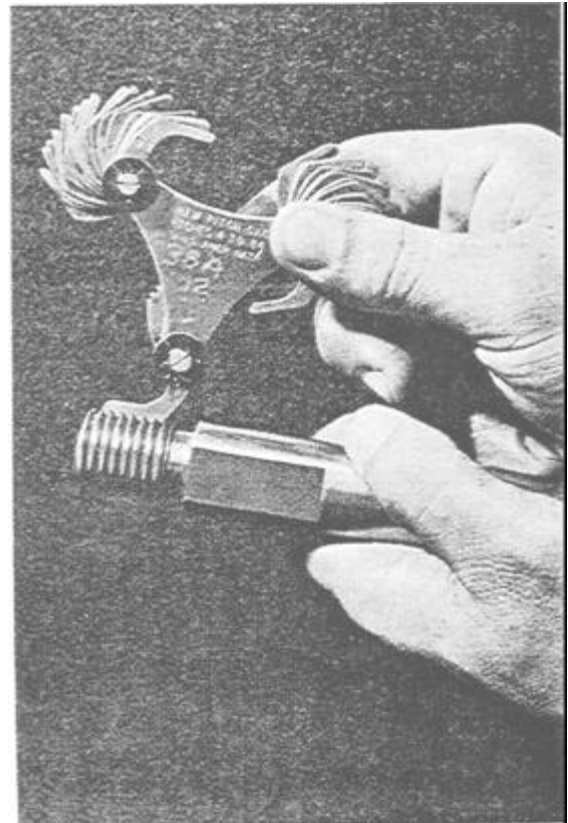
After setting up the lathe, as explained previously, take a very light trial cut just deep enough to scribe a line on the surface of the work, as shown in view A of figure 6-93. The purpose of this trial cut is to be sure that the lathe is arranged for cutting the desired pitch of thread.

To check the number of threads per inch, place a rule against the work, as shown in view B of figure 6-93, so that the end of the rule rests on the point of a thread or on one of the scribed lines. Count the scribed lines between the end of the rule and the first inch mark. This will give the number of threads per inch.

It is quite difficult to accurately count fine pitches of screw threads. A screw pitch gauge, used as illustrated in figure 6-94, is very convenient for checking the finer screw threads. The gauge consists of a number of sheet metal plates in which are cut the exact forms of threads of the various pitches; each plate is stamped with a number indicating the number of threads per inch for which it is to be used.

If the thread-cutting tool needs resharpening or gets out of alignment or if you are chasing the threads on a previously threaded piece, you must reset the tool so it will follow the original thread groove. To reset the tool, you may (1) use the compound rest feed screw and cross-feed screw to jockey the tool to the proper position, (2) disengage the change gears and turn the spindle until the tool is positioned properly, or (3) loosen the lathe dog (if used) and turn the work until the tool is in the proper position in the thread groove. Regardless of which method you use, you will usually have to reset the micrometer collars on the cross-feed screw and the compound rest screw.

Before adjusting the tool in the groove, use the appropriate thread gauge to set the tool square with the workpiece. Then, with the tool a few thousandths of an inch away from the workpiece, start the machine and engage the threading mechanism. When the tool has moved to a position near the groove into which you plan to put the tool, such as that shown by the solid tool in figure 6-95, stop the lathe without disengaging the thread mechanism.



28.153

Figure 6-44—Screw pitch gauge.

To reset the cutting tool into the groove, you will probably use the compound rest and cross-feed positioning method. By adjusting the compound rest slide forward or backward, you can move the tool laterally to the axis of the work as well as toward or away from the work. When the point of the tool coincides with the original thread groove (phantom view of the tool in fig. 6-95), use the cross-feed screw to bring the tool point directly into the groove. When you get a good fit between the cutting tool and the thread groove, set the micrometer collar on the cross-feed screw on zero and set the micrometer

Deleted—No permission  
granted for electronic copy.

Deleted—No permission  
granted for electronic copy.

Figure 6-93.—The first cut.

Figure 6-95.—Tool must be reset to original groove.

Deleted—No permission granted for electronic copy.

Figure 6-96.—Finishing the end of a threaded piece.

collar on the compound rest feed screw to the depth of cut previously taken.

**NOTE:** Be sure that the thread mechanism is engaged and the tool is set square with the work before adjusting the position of the tool along the axis of the workpiece.

If it is inconvenient to use the compound rest for readjusting the threading tool, loosen the lathe dog (if used); turn the work so that the threading tool will match the groove, and tighten the lathe dog. If possible, however, avoid doing this.

Another method, which is sometimes used, is to disengage the reverse gears or the change gears; turn the headstock spindle until the point of the threading tool enters the groove in the work, and then reengage the gears.

The end of a thread may be finished by any one of several methods. The 45° chamfer on the end of a thread, as shown in view A of figure 6-96, is commonly used for bolts and capscrews. For machined parts and special screws, the end is often finished by rounding it with a forming tool, as shown in view B of figure 6-96.

## LEFT-HAND SCREW THREADS

A left-hand screw (fig. 6-97) turns counter-clockwise when advancing (looking at the head of the screw), or just the opposite to a right-hand screw.

Deleted—No permission granted for electronic copy.

Figure 6-97.—A left-hand screw thread.

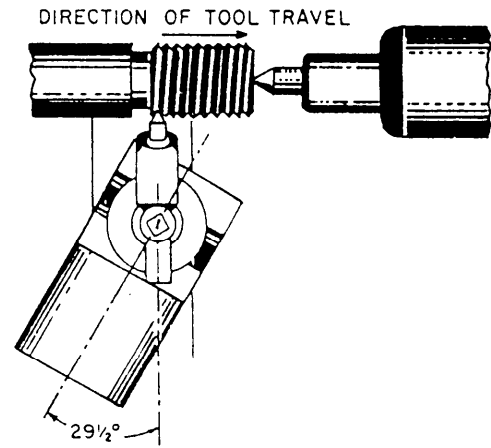


Figure 6-98.—Setup for left-hand external threads.

Left-hand threads are used for the cross-feed screws of lathes, the left-hand end of axles, one end of a turnbuckle, or wherever an opposite thread is desired.

The directions for cutting a left-hand thread on a lathe are the same as those for cutting a right-hand thread, except that you swivel the compound rest to the left instead of to the right. Figure 6-98 shows the correct position for the compound rest. The direction of travel for the tool differs from a right-hand thread in that it moves toward the tailstock as the thread is being cut.

Before starting to cut a left-hand thread, it is good practice, if feasible, to cut a neck or groove into the workpiece. (See fig. 6-97). Such a groove enables you to run the tool in for each pass, as you do for a right-hand thread.

Make the final check for both diameter and pitch of the thread, whether right-hand or left-hand, with the nut that is to be used, or with a ring thread gauge if one is available. The nut should fit snugly without play or shake, but it should not bind on the thread at any point.

## MULTIPLE SCREW THREADS

A multiple thread, as shown in figure 6-99, is a combination of two or more threads, parallel to each other, progressing around the surface into which they are cut. If a single thread is thought of as taking the form of a helix, that is of a string or cord wrapped around a cylinder, a multiple thread may be thought of as several cords lying side by side and wrapped around a cylinder. There may be any number of threads, and they start at equally spaced intervals around the cylinder. Multiple threads are used when

rapid movement of the nut or other attached parts is desired and when weakening of the thread must be avoided. A single thread having the same lead as a multiple thread would be very deep compared to the multiple thread. The depth of the thread is calculated according to the pitch of the thread.

The tool selected for cutting multiple threads has the same shape as that of the thread to be cut and is similar to the tool used for cutting a single thread except that greater side clearance is necessary. The helix angle of the thread increases as the number of threads increases. The general method for cutting multiple threads is about the same as for single screw threads, except that the lathe gearing must be based on the lead of the thread (number of single threads per inch), and not the pitch, as shown in figure 6-99. Provisions must also be made to obtain the correct spacing of the different thread grooves. You can get the proper spacing by using the thread-chasing dial, setting the compound rest parallel to the ways, using a faceplate, or using the change gear box mechanism.

The use of the thread-chasing dial (fig. 6-100) is the most desirable method for cutting 60° multiple threads. With each setting for depth of cut with the compound, you can take successive cuts on each of the multiple threads so that you can use thread micrometers.

To determine the possibility of using the thread-chasing dial, first find out if the lathe can be geared to cut a thread identical to one of the multiple threads. For example, if you want to cut 10 threads per inch, double threaded, divide the number of threads per inch (10) by the multiple (2) to get the number of single threads per inch (5). Then, gear the lathe for 5 threads per inch.

To use the thread-chasing dial on a specific machine, refer to instructions usually found attached

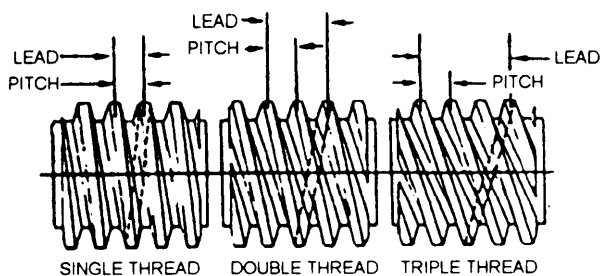


Figure 6-99.—Comparison of single- and multiple-lead threads.

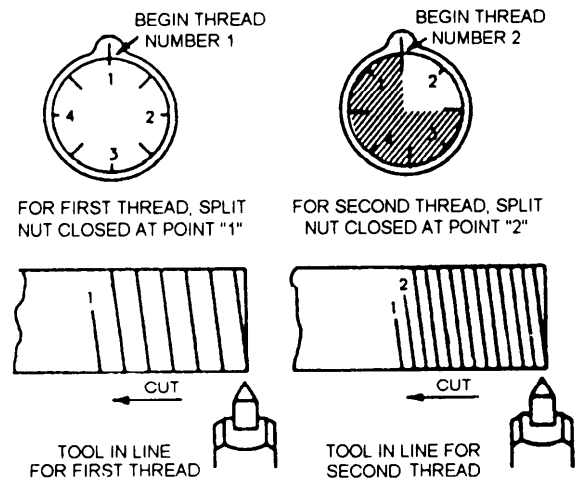


Figure 6-100.—Cutting multiple threads using the thread-chasing dial.

to the lathe apron. To cut 5 threads per inch, on most lathes, engage the half-nut at any numbered line on the dial, such as points 1 and 2 shown in figure 6-100. The second groove of a double thread lies in the middle of the flat surface between the grooves of the first thread. Engage the half-nut to begin cutting the second thread when an unnumbered line passes the index mark, as shown in figure 6-100. To ensure that you cut each thread to the same depth, engage the half-nut first at one of the numbered positions and cut in the first groove. Then, engage the half-nut at an unnumbered position so that alternate cuts bring both thread grooves down to size together. To cut a multiple thread with an even number of threads, first use the thread-chasing dial to cut the first thread. Then, use one of the other multiple thread-cutting procedures to cut the second thread.

Cutting of multiple threads by positioning the compound rest parallel to the ways should be limited to square and Acme threads. To use this method, set the compound rest parallel to the ways of the lathe and cut the first thread to the finished size. Then, feed the compound rest and tool forward, parallel to the thread axis a distance equal to the pitch of the thread and cut the next thread.

The faceplate method of cutting multiple threads involves changing the position of the work between centers for each groove of the multiple thread. One method is to cut the first thread groove in the conventional manner. Then, remove the work from between centers and replace it between centers so the tail of the dog is in another slot of the drive plate, as

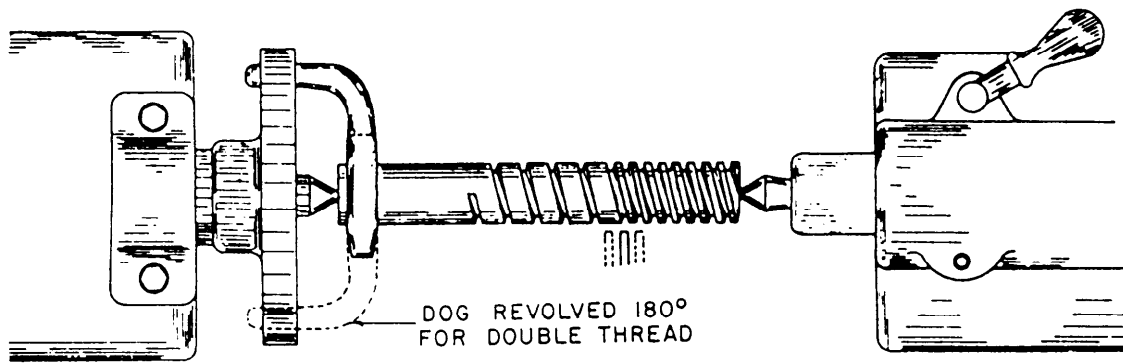


Figure 6-101.—Use of faceplate.

shown in figure 6-101. Two slots are necessary for a double thread, three slots for a triple thread, and so on. The number of multiples you can cut by this method depends on the number of equally spaced slots there are in the drive plate. There are special drive or index plates available, so that you can accurately cut a wide range of multiples by this method.

Another method of cutting multiple threads is to disengage either the stud gear or the spindle gear from the gear train in the end of the lathe after you cut a thread groove. Then, turn the work and the spindle the required part of a revolution, and reengage the gears for cutting the next thread. If you are to cut a double thread on a lathe that has a 40-tooth gear on the spindle, cut the first thread groove in the ordinary manner. Then, mark one of the teeth on the spindle gear that meshes with the next driven gear. Carry the mark onto the driven gear, in this case the reversing gear. Also, mark the tooth diametrically opposite the marked spindle gear tooth (the 20th tooth of the 40-tooth gear). Count the tooth next to the marked tooth as tooth number one. Then disengage the gears by placing the tumbler (reversing) gears in the neutral position, turn the spindle one-half revolution or 20 teeth on the spindle gear, and reengage the gear train. You may index the stud gear as well as the spindle gear. If the ratio between the spindle and stud gears is not 1 to 1, you will have to give the stud gear a proportional turn, depending upon the gearing ratio. The method of indexing the stud or spindle gears is possible only when you can evenly divide the number of teeth in the gear indexed by the multiple desired. Some lathes have a sliding sector gear that you can readily insert into or remove from the gear train by shifting a lever. Graduations on the end of the spindle show when to disengage and to reengage the sector gear for cutting various multiples.

## THREADS ON TAPERED WORK

Use the taper attachment when you cut a thread on tapered work. If your lathe does not have a taper attachment, cut the thread on tapered work by setting over the tailstock. The setup is the same as for turning tapers.

Part A of figure 6-102 shows the method of setting the threading tool with the thread gauge when you use the taper attachment. Part B of figure 6-102 shows the same operation for using the tailstock setover method.

Note that in both methods illustrated in figure 6-102, you set the threading tool square with the axis by placing the center gauge on the straight part of the work, NOT on the tapered section. This is very important.

Deleted—No permission granted for electronic copy.

Figure 6-102.—Cutting thread on tapered work.



## CHAPTER 7

# MILLING MACHINES AND MILLING OPERATIONS

### CHAPTER LEARNING OBJECTIVES

*Upon completing this chapter, you should be able to do the following:*

- *Describe and explain the use of milling machines.*
- *Describe the major components of milling machines.*
- *Describe and explain the use of workholding devices.*
- *Describe and explain the use of milling machine attachments.*
- *Explain indexing.*
- *Explain the selection and use of milling cutters.*
- *Explain milling machine setup and operation.*
- *Explain the use of feeds, speeds, and coolants in milling operations.*

A milling machine removes metal with a revolving cutting tool called a milling cutter. With various attachments, you can use milling machines for boring, slotting, circular milling, dividing, and drilling; cutting keyways, racks, and gears; and fluting taps and reamers.

You must be able to set up the milling machine to machine flat, angular, and formed surfaces. These jobs include the keyways, hexagonal and square heads on nuts and bolts, T-slots and dovetails, and spur gear teeth. To set up the machine, you must compute feeds and speeds, and select and mount the proper holding device and the proper cutter to handle the job.

You must also know how to align and level the machine. Manufacturers provide these instructions for their machines; follow them carefully.

As with any shop equipment you must observe all posted safety precautions. Review your equipment operators manual for safety precautions and any chapters of *Navy Occupational Safety and Health (NAVOSH) Program Manual for Forces Afloat*, OPNAV Instruction 5100.19B, that pertain to the equipment you will be operating.

Most Navy machine shops have the knee and column type of milling machine. This machine has a fixed spindle and a vertically adjustable table. We will discuss the knee and column type of milling machine in this chapter, but keep in mind that most of the information we give you also applies to other types of milling machines such as a horizontal boring mill, which is a typical bed-type milling machine.

The Navy uses three types of knee and column milling machines; the universal, the plain, and the vertical spindle, which we will describe in the next paragraphs. Where only one type can be installed, the universal type is usually selected.

The UNIVERSAL MILLING MACHINE (fig. 7-1) has all the principal features of the other types of milling machines. It can handle nearly all classes of milling work. You can take vertical cuts by feeding the table up or down. You can move the table in two directions in the horizontal plane—either at a right angle to, or parallel to, the axis of the spindle. The principal advantage of the universal mill over the plain mill is that you can swivel the table on the saddle. Therefore, you can move the table in the horizontal plane at an angle to the axis of the spindle.

Deleted—No permission  
granted for electronic copy.

Deleted—No permission  
granted for electronic copy.

**Figure 7-1.—Universal milling machine.**

**Figure 7-2.—Plain milling machine.**

Deleted—No permission  
granted for electronic copy.

**Figure 7-3.—Vertical spindle milling machine.**

Deleted—No permission  
granted for electronic copy.

Deleted—No permission  
granted for electronic copy.

**Figure 7-4.—Small vertical milling machine.**

This machine is used to cut most types of gears, milling cutters, and twist drills and is used for various kinds of straight and taper work.

The PLAIN MILLING MACHINE (fig. 7-2) is the simplest milling machine because it has only a few of the features found on the other machines. You can move the table in three directions: longitudinally (at a right angle to the spindle), transversely (parallel to the spindle), and vertically (up and down). This machine's major advantage is its ability to take heavy cuts at fast speeds. The machine's rigid construction makes this possible.

The VERTICAL SPINDLE MILLING MACHINE (fig. 7-3) has the spindle in a vertical position and at a right angle to the surface of the table. The spindle has a vertical movement, and the table can be moved vertically, longitudinally, and transversely. You can control movement of both the spindle and the table manually or by power. You can use this machine for face milling, profiling, and die sinking and for various odd-shaped jobs. You also can use it used to advantage to bore holes. Various small vertical spindle milling machines (fig. 7-4) are also available for light, precision milling operations.

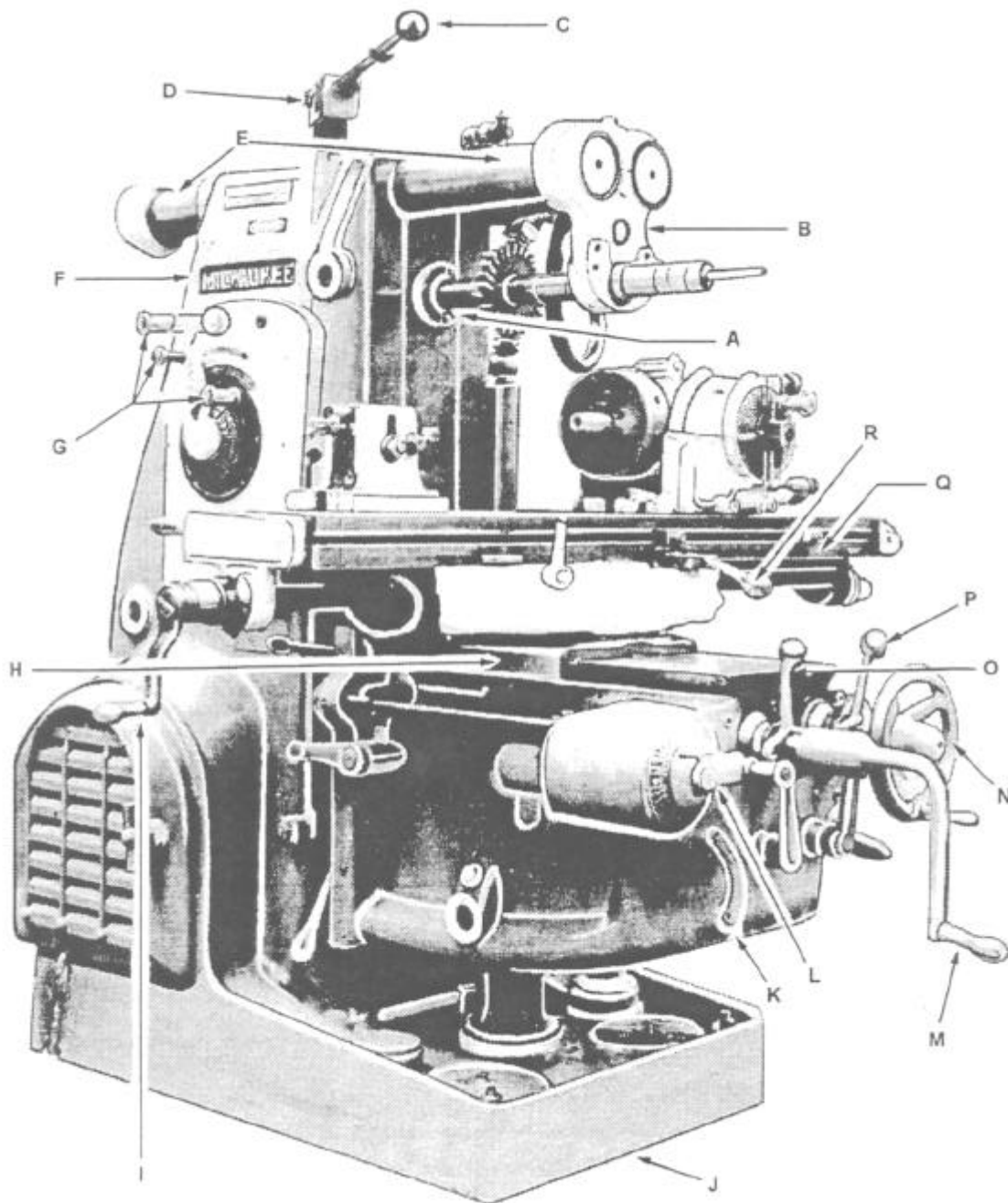
**Figure 7-5.—Plain milling machine, showing operation controls.**

## MAJOR COMPONENTS

You must know the name and purpose of each of the main parts of a milling machine to understand the operations discussed later in this chapter. Keep in mind that although we are discussing a knee and column milling machine you can apply most of the information to the other types.

Figure 7-5 shows a plain knee and column milling machine, and figure 7-6 shows a universal knee and column milling machine. Look at these figures to help you identify the components described in the following paragraphs.

**COLUMN:** The column, including the base, is the main casting that supports all other parts of the machine. An oil reservoir and a pump in the column keep the spindle lubricated. The column rests on a base that contains a coolant reservoir and a pump that you can use when you perform any machining operation that requires a coolant.



- |                         |                                  |                              |
|-------------------------|----------------------------------|------------------------------|
| A. Spindle              | G. Spindle speed selector levers | M. Knee elevating crank      |
| B. Arbor support        | H. Saddle and swivel             | N. Transverse handwheel      |
| C. Spindle clutch lever | I. Longitudinal handcrank        | O. Vertical feed control     |
| D. Switch               | J. Base                          | P. Transverse feed control   |
| E. Overarm              | K. Knee                          | Q. Table feed trip dog       |
| F. Column               | L. Feed dial                     | R. Longitudinal feed control |

Figure 7-6.—Universal knee and column milling machine with horizontal spindle.

28.366

**KNEE:** The knee is the casting that supports the table and the saddle. The feed change gearing is enclosed within the knee. It is supported and is adjusted by turning the elevating screw. The knee is fastened to the column by dovetail ways. You can raise or lower the knee by either hand or power feed. You usually use hand feed to take the depth of cut or to position the work and power feed to move the work during the operation.

**SADDLE and SWIVEL TABLE:** The saddle slides on a horizontal dovetail (which is parallel to the axis of the spindle) on the knee. The swivel table (on universal machines only) is attached to the saddle and can be swiveled approximately 45° in either direction.

**POWER FEED MECHANISM:** The power feed mechanism is contained in the knee and controls the longitudinal, transverse (in and out), and vertical feeds. To set the rate of feed on machines, like the one in figure 7-5, position the feed selection levers as indicated on the feed selection plate. On machines like the one in figure 7-6, turn the speed selection handle until the desired rate of feed is indicated on the feed dial. Most milling machines have a rapid traverse lever that you can engage when you want to temporarily increase the speed of the longitudinal, transverse, or vertical feeds. For example, you would engage this lever to position or align the work.

**NOTE:** For safety reasons, you must use extreme caution whenever you use the rapid traverse controls.

**TABLE:** The table is the rectangular casting located on top of the saddle. It contains several T-slots in which you can fasten work or workholding devices. You can move the table by hand or by power. To move it by hand, engage and turn the longitudinal handcrank. To move it by power, engage the longitudinal directional feed control lever. You can

position this lever to the left, to the right, or in the center. Place the end of the lever to the left to feed the table toward the left. Place it to the right to feed the table toward the right. Place it in the center to disengage the power feed or to feed the table by hand.

**SPINDLE:** The spindle holds and drives the various cutting tools. It is a shaft mounted on bearings supported by the column. The spindle is driven by an electric motor through a train of gears, all mounted within the column. The front end of the spindle, which is near the table, has an internal taper machined in it. The internal taper (3 1/2 inches per foot) permits you to mount tapered-shank cutter holders and cutter arbors. Two keys, located on the face of the spindle, provide a positive drive for the cutter holder, or arbor. You secure the holder, or arbor, in the spindle by a drawbolt and jamnut, as shown in figure 7-7. Large face mills are sometimes mounted directly to the spindle nose.

**OVERARM:** The overarm is the horizontal beam to which you fasten the arbor support. The overarm may be a single casting that slides in dovetail ways on the top of the column (fig. 7-5) or it may consist of one or two cylindrical bars that slide through holes in the column, as shown in figure 7-6. To position the overarm on some machines, first unclamp locknuts and then extend the overarm by turning a crank. On others, move the overarm by simply pushing on it. You should extend the overarm only far enough to position the arbor support to make the setup as rigid as possible. To place arbor supports on an overarm such as the one shown as B in figure 7-6, extend one of the bars approximately 1 inch farther than the other bar. Tighten the locknuts after you position the overarm. On some milling machines the coolant supply nozzle is fastened to the overarm. You can mount the nozzle

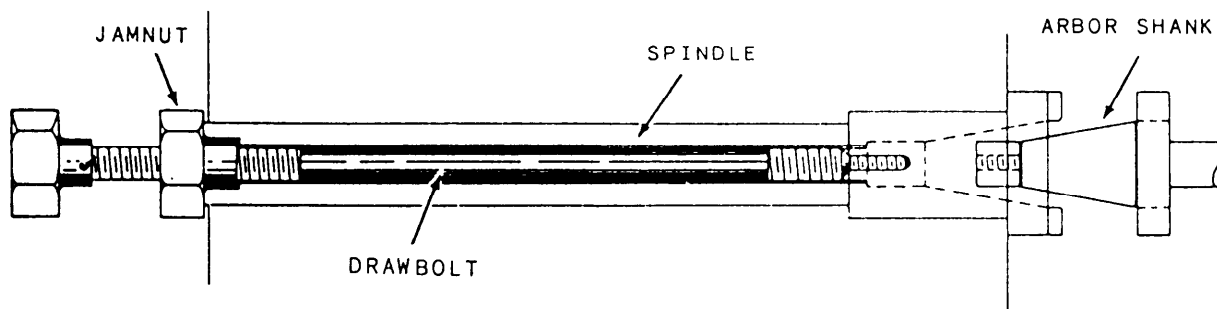


Figure 7-7.—Spindle drawbolt.

Deleted—No permission  
granted for electronic copy.

**Figure 7-8.—Milling machine vises.**

with a split clamp to the overarm after you have placed the arbor support in position.

**ARBOR SUPPORT:** The arbor support is a casting that contains a bearing that aligns the outer end of the arbor with the spindle. This helps to keep the arbor from springing during operations. Two types of arbor supports are commonly used. One has

a small diameter bearing hole, usually 1-inch maximum diameter. The other has a large diameter bearing hole, usually up to 2 3/4 inches. An oil reservoir in the arbor support keeps the bearing surfaces lubricated. You can clamp an arbor support at any place you want on the overarm. Small arbor supports give additional clearance below the arbor supports when you are using small diameter cutters.

However, small arbor supports can provide support only at the extreme end of the arbor. For this reason they are not recommended for general use. Large arbor supports can provide support near the cutter, if necessary.

**NOTE:** Before loosening or tightening the arbor nut, you must install the arbor support. This will prevent bending or springing of the arbor.

**MACHINE DESIGNATION:** All milling machines are identified by four basic factors: size, horsepower, model, and type. The size of a milling machine is based on the longitudinal (from left to right) table travel in inches. Vertical, cross, and longitudinal travel are all closely related as far as overall capacity is concerned. For size designation, only the longitudinal travel is used. There are six sizes of knee-type milling machines, with each number representing the number of inches of travel.

<u>Standard Size</u>	<u>Longitudinal Table Travel</u>
No. 1	22 inches
No. 2	28 inches
No. 3	34 inches
No. 4	42 inches
No. 5	50 inches
No. 6	60 inches

If the milling machine in your shop is labeled No. 2HL, it has a table travel of 28 inches; if it is labeled No. 5LD, it has a travel of 50 inches. The model designation is determined by the manufacturer, and features vary with different brands. The type of milling machine is designated as plain or universal, horizontal or vertical, and knee and column or bed. In addition, machines may have other special type designations.

Standard equipment used with milling machines in Navy ships includes workholding devices, spindle attachments, cutters, arbors, and any special tools needed to set up the machines for milling. This equipment allows you to hold and cut the great variety of milling jobs you will find in Navy repair work.

## WORKHOLDING DEVICES

The following workholding devices are the ones you will probably use most frequently.

### VICES

The vises commonly used on milling machines are the flanged plain vise, the swivel vise, and the

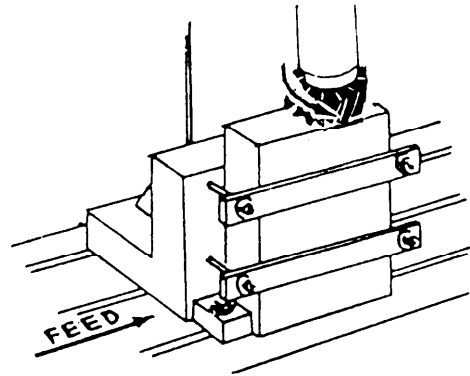


Figure 7-9.—Right-angle plate.

toolmaker's universal vise (fig. 7-8). The flanged vise provides the most support for a rigid workpiece. The swivel vise is similar to the flanged vise, but the setup is less rigid because the workpiece can be swiveled in a horizontal plane to any required angle. The toolmaker's universal vise provides the least rigid support because it is designed to set up the workpiece at a complex angle in relation to the axis of the spindle and to the surface of the table.

### RIGHT-ANGLE PLATE

The right-angle plate (fig. 7-9) is attached to the table. The right-angle slot permits mounting the index head so the axis of the head is parallel to the milling machine spindle. With this attachment you can make work setups that are off center or at a right angle to the table T-slots. The standard size plate T-slots make it convenient to change from one setting to another to mill a surface at a right angle.

### TOOLMAKER'S KNEE

The toolmaker's knee (fig. 7-10) is a simple but useful attachment used to set up angular work, not only for milling but also for shaper, drill press, and grinder operations. You mount a toolmaker's knee, which may have either a stationary or rotatable base,

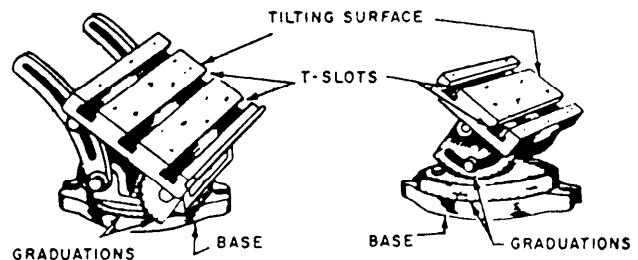


Figure 7-10.—Toolmaker's knees.

to the table of the milling machine. The base of the rotatable type is graduated in degrees. This feature allows you to machine compound angles. The toolmaker's knee has a tilting surface with a built-in protractor head graduated in degrees to set the table or a vernier scale for more accurate settings.

### **CIRCULAR MILLING ATTACHMENT**

The circular milling attachment, or rotary table (fig. 7-11), is used to set up work that must be rotated in a horizontal plane. The worktable is graduated

(1/2° to 360°) around its circumference. You can turn the table by hand or by the table feed mechanism through a gear train, as shown in figure 7-11. An 80 to 1 worm and gear drive contained in the rotary table and index plate arrangement makes this device useful for accurate indexing of horizontal surfaces.

### **INDEXING EQUIPMENT**

Indexing equipment (fig. 7-12) is used to hold and turn the workpiece so that a number of accurately spaced cuts can be made (gear teeth for example).

Deleted—No permission  
granted for electronic copy.

**Figure 7-11.—Circular milling attachment with power feed mechanism.**



Deleted—No permission granted for electronic copy.

Figure 7-12.—Indexing equipment.

The workpiece may be held in a chuck or a collet, attached to the dividing head spindle, or held between a live center in the dividing index head and a dead center in the footstock. The center of the footstock can be raised or lowered to set up tapered workpieces. The center rest can be used to support long slender work.

Figure 7-13 shows the internal components of the dividing head. The ratio between the worm and the gear is 40 to 1. By turning the worm one turn, you rotate the spindle  $1/40$  of a revolution. The index plate has a series of concentric circles of holes. You can use these holes to gauge partial turns of the worm shaft and to turn the spindle accurately in amounts smaller than  $1/40$  of a revolution. You can secure the index plate either to the dividing head housing or to a rotating shaft and you can adjust the crankpin radially for use in any circle of holes. You can also set the sector arms as a guide to span any number of holes in the index plate to provide a guide to rotate the index crank for partial turns. To rotate the workpiece, you

can turn the dividing head spindle one of two ways: Do it directly by hand by disengaging the worm and drawing the plunger back, or by the index crank through the worm and worm gear.

The spindle is set in a swivel block so you can set the spindle at any angle from slightly below horizontal to slightly past vertical. We said earlier

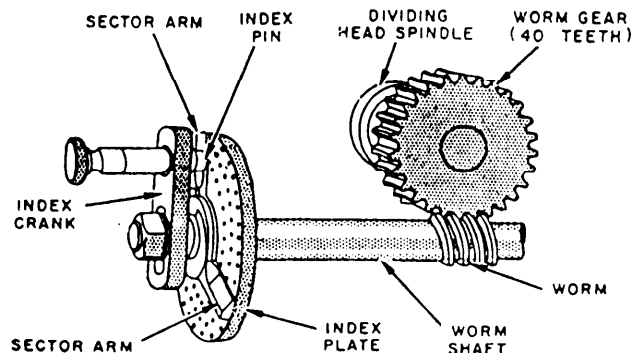


Figure 7-13.—Dividing head mechanism.

that most index heads have a 40 to 1 ratio. One well-known exception has a 5 to 1 ratio (see fig. 7-14). This ratio is made possible by a 5 to 1 gear ratio between the index crank and the dividing head spindle. The faster movement of the spindle with one turn of the index crank permits speedier production. It is also an advantage when you true work or test it for run out with a dial indicator. While this dividing head is made to a high standard of accuracy, it does not permit as wide a selection of divisions by simple indexing. Later in this chapter, we'll discuss differential indexing that you can do on the 5 to 1 ratio dividing head by using a differential indexing attachment.

The dividing head (also called an index head) may also be geared to the lead screw of the milling machine by a driving mechanism to turn the work-as required for helical and spiral milling. The index head may have one of several driving mechanisms. The most common of these is the ENCLOSED DRIVING MECHANISM, which is standard equipment on some makes of plain and universal knee and column milling machines. The enclosed driving mechanism has a lead range of 2 1/2 to 100 inches and is driven directly from the lead screw.

Figure 7-15 shows the gearing arrangement used on most milling machines. The gears are marked as follows:

- A = Gear on the worm shaft (driven)
- B = First gear on the idler stud (driving)
- C = Second gear on idler stud (driven)
- D = Gear on lead screw (driving)
- E and F = Idler gears

**LOW LEAD DRIVE:** For some models and makes of milling machines a low lead driving mechanism is available; however, additional parts must be built into the machine at the factory. This driving mechanism has a lead range of 0.125 to 100 inches.

**LONG and SHORT LEAD DRIVE:** When an extremely long or short lead is required, you can use the long and short lead attachment (fig. 7-16). As with the low-lead driving mechanism, the milling machine must have certain parts built into the machine at the factory. In this attachment, an auxiliary shaft in the table drive mechanism supplies power through the gear train to the dividing head. It also supplies the power for the table lead screw, which is disengaged from the regular drive when the attachment is used. This attachment provides leads in the range between 0.010 and 1000 inches.

Deleted—No permission granted for electronic copy.

**Figure 7-14.—Universal spiral dividing head with a 5 to 1 ratio between the spindle and the index crank.**

Deleted—No permission granted for electronic copy.

**Figure 7-15.—Enclosed driving mechanism.**

Deleted—No permission granted for electronic copy.

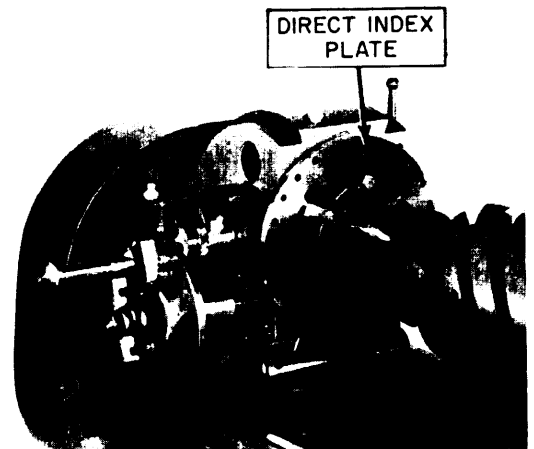
Figure 7-16.—The long and short lead attachment.

## INDEXING THE WORK

Indexing is done by the direct, plain, compound, or differential method. The direct and plain methods are the most commonly used; the compound and differential methods are used only when the job cannot be done by plain or direct indexing.

### DIRECT INDEXING

Direct indexing, sometimes referred to as rapid indexing, is the simplest method of indexing. Figure 7-17 shows the front index plate attached to the work spindle. The front index plate usually has 24 equally spaced holes. These holes can be engaged by the front index pin, which is spring-loaded and moved in and out by a small lever. Rapid indexing requires that the worm and the worm wheel be disengaged so that the spindle can be moved by hand. Numbers that can be divided into 24 can be indexed in this manner.



*Courtesy of Brown and Sharpe Manufacturing Company*

28.209

Figure 7-17.—Direct index plate.

Rapid indexing is used when a large number of duplicate parts are to be milled.

To find the number of holes to move the index plate, divide 24 by the number of divisions required.

Number of holes to move =  $24 / N$  where  $N$  = required number of divisions

Example: Indexing for a hexagon head bolt: because a hexagon head has six flats,

$$\frac{24}{N} = \frac{24}{6} = 4 \text{ holes}$$

**IN ANY INDEXING OPERATION, ALWAYS START COUNTING FROM THE HOLE ADJACENT TO THE CRANKPIN.** During heavy cutting operations, clamp the spindle by the clamp screw to relieve strain on the index pin.

### PLAIN INDEXING

Plain indexing, or simple indexing, is used when a circle must be divided into more parts than is possible by rapid indexing. Simple indexing requires that the spindle be moved by turning an index crank, which turns the worm that is meshed with the worm wheel. The ratio between worm and the worm wheel is 40 to 1. One turn of the index crank turns the index head spindle  $1/40$  of a complete turn. Therefore, 40 turns of the index crank are required to revolve the spindle chuck and the job 1 complete turn. To determine the number of turns or fractional parts of a turn of the index crank necessary to cut any required number of divisions, divide 40 by the number of divisions required.

$$\text{Number of turns of the index crank} = \frac{40}{N}$$

where  $N$  = number of divisions required

Example 1: Index for five divisions

$$\frac{40}{N} = \frac{40}{5} = 8 \text{ turns}$$

There are eight turns of the crank for each division.

Example 2: Index for eight divisions

$$\frac{40}{N} = \frac{40}{8} = 5 \text{ turns}$$

Example 3: Index for 10 divisions

$$\frac{40}{N} = \frac{40}{10} = 4 \text{ turns}$$

When the number of divisions required does not divide evenly into 40, the index crank must be moved a fractional part of a turn with index plates. A commonly used index head comes with three index plates. Each plate has six circles of holes, which we will use as an example.

Plate 1: 15-16-17-18-19-20

Plate 2: 21-23-27-29-31-33

Plate 3: 37-39-41-43-47-49

The previous examples of using the indexing formula  $40/N$  gave results in complete turns of the index crank. This seldom happens on the typical indexing job. For example, indexing for 18 divisions

$$\frac{40}{N} = \frac{40}{18} = 2 \frac{4}{18} \text{ turns}$$

The whole number indicates the complete turns of the index crank, the denominator of the fraction represents the index circle, and the numerator represents the number of holes to use on that circle. Because there is an 18-hole index circle, the mixed number  $2 \frac{4}{18}$  indicates that the index crank will be moved 2 full turns plus 4 holes on the 18-hole circle that you will find on index plate 1. The sector arms are positioned to include 4 holes and the hole in which the index crankpin is engaged. The number of holes (4) represents the movement of the index crank; the hole that engages the index crankpin is not included.

When the denominator of the indexing fraction is smaller or larger than the number of holes contained in any of the index circles, change it to a number representing one of the circles of holes. Do this by multiplying or dividing the numerator and the denominator by the same number. For example, to index for the machining of a hexagon ( $N = 6$ ):

$$\frac{40}{N} = \frac{40}{6} \times \frac{3}{3} = \frac{120}{18} = 6 \frac{12}{18} = 6 \frac{2}{3} \text{ turns}$$

The denominator 3 will divide equally into the following circles of holes, so you can use any plate that contains one of the circles.

Plate 1: 15 and 18

Plate 2: 21 and 33

Plate 3: 39

To apply the fraction  $2/3$  to the circle you choose, convert the fraction to a fraction that has the number of holes in the circle as a denominator. For example, if you choose the 15-hole circle, the fraction  $2/3$  becomes  $10/15$ . If plate 3 happens to be on the index head, multiply the denominator 3 by 13 to equal 39. In order not to change the value of the original indexing fraction, also multiply the numerator by 13.

$$\frac{2}{3} \times \frac{13}{13} = \frac{26}{39}$$

The original indexing rotation of  $6 \frac{2}{3}$  turns becomes  $6 \frac{26}{39}$  turns. Thus, to mill each side of a hexagon, you must move the index crank 6 full turns and 26 holes on the 39-hole circle.

When there are more than 40 divisions, you may divide both the numerator and the denominator of the fraction by a common divisor to obtain an index circle that is available. For example, if 160 divisions are required,  $N = 160$ ; the fraction to be used is

$$\frac{40}{N} = \frac{40}{160}$$

Because there is no 160-hole circle, this fraction must be reduced. To use a 16-hole circle, divide the numerator and denominator by 10.

$$\frac{40/10}{160/10} = \frac{4}{16}$$

Turn 4 holes on the 16-hole circle.

It is usually more convenient to reduce the original fraction to its lowest terms and then multiply both terms of the fraction by a factor that will give a number representing a circle of holes.

$$\frac{40}{160} = \frac{1}{4}$$

$$\frac{1}{4} \times \frac{4}{4} = \frac{4}{16}$$

The following examples will further clarify the use of this formula:

Example 1: Index for 9 divisions.

$$\frac{40}{N} = \frac{40}{9} = 4 \frac{4}{9}$$

If an 18-hole circle is used, the fraction becomes  $4/9 \times 2/2 = 8/18$ . For each division, turn the crank 4 turns and 8 holes on an 18-hole circle.

Example 2: Index for 136 divisions.

$$\frac{40}{N} = \frac{40}{136} = \frac{5}{17}$$

There is a 17-hole circle, so for each division turn the crank 5 holes on a 17-hole circle.

When setting the sector arms to space off the required number of holes on the index circle, DO NOT count the hole that the index crankpin is in.

Most manufacturers provide different plates for indexing. Later model Brown and Sharpe index heads use two plates with the following circle of holes:

Plate 1: 15, 16, 19, 23, 31, 37, 41, 43, 47

Plate 2: 17, 18, 20, 21, 27, 29, 33, 39, 47

The standard index plate supplied with the Cincinnati index head is provided with 11 different circles of holes on each side.

Side 1: 24-25-28-30-34-37-38-39-41-42-43

Side 2: 46-47-49-51-53-54-57-58-59-62-66

## ANGULAR INDEXING

When you must divide work into degrees or fractions of a degree by plain indexing, remember that one turn of the index crank will rotate a point on the circumference of the work  $1/40$  of a revolution. Since there are  $360^\circ$  in a circle, one turn of the index crank will revolve the circumference of the work  $1/40$  of  $360^\circ$ , or  $9^\circ$ . Therefore, to use the index plate and fractional parts of a turn, 2 holes in an 18-hole circle equal  $1^\circ$  ( $1/9$  turn  $\times 9^\circ/\text{turn}$ ), 1 hole in a 27-hole circle equals  $1/3^\circ$  ( $1/27$  turn  $\times 9^\circ/\text{turn}$ ), 3 holes in a 54-hole circle equal  $1/2^\circ$  ( $1/18$  turn  $\times 9^\circ/\text{turn}$ ). To determine the number of turns and parts of a turn of the index crank for a desired number of degrees, divide the number of degrees by 9. The quotient will represent the number of complete turns and fractions of a turn that you should rotate the index crank. For example, use the following calculation to determine  $15^\circ$  when an index plate with a 54-hole circle is available.

$$\frac{15}{9} = 1 \frac{6}{9} \times \frac{6}{6} = 1 \frac{36}{54}$$

or one complete turn plus 36 holes on the 54-hole circle. The calculation to determine  $13\ 1/2^\circ$  when an index plate with an 18-hole circle is available, is as follows:

$$\frac{13.5}{9} = 1\ \frac{4.5}{9} \times \frac{2}{2} = 1\ \frac{9}{18}$$

or one complete turn plus 9 holes on the 18-hole circle.

When indexing angles are given in minutes, and approximate divisions are acceptable, you can determine the movement of the index crank and the proper index plate by the following calculations. To determine the number of minutes represented by one turn of the index crank, multiply the number of degrees covered in one turn of the index crank by 60:

$$9^\circ \times 60' = 540$$

Therefore, one turn of the index crank will rotate the index head spindle 540 minutes.

The number of minutes (540) divided by the number of minutes in the division desired gives you the total number of holes there should be in the index plate used. (Moving the index crank one hole will rotate the index head spindle through the desired number of minutes of angle.) This method of indexing can be used only for approximate angles since ordinarily the quotient will come out in mixed numbers or in numbers for which there are no index plates available. However, when the quotient is nearly equal to the number of holes in an available index plate, the nearest number of holes can be used and the error will be very small. For example the calculation for 24 minutes would be

$$\frac{540}{24} = \frac{22.5}{1}$$

or 1 hole on the 22.5-hole circle. Since the index plate has no 22.5-hole circle, you should use a 23-hole circle plate.

If a quotient is not approximately equal to an available circle of holes, multiply by any trial number that will give a product equal to the number of holes in one of the available index circles. You can then move the crank the required number of holes to give the desired division. For example, use the following calculation to determine 54 minutes when an index plate that has a 20-hole circle is available.

$$\frac{54}{540} = \frac{1}{10} \times \frac{2}{2} = \frac{2}{20} \text{ (no. of holes) (20-hole circle)}$$

or 2 holes on the 20-hole circle.

## COMPOUND INDEXING

Compound indexing is a combination of two plain indexing procedures. You will index one number of divisions by using the standard plain indexing method, and another by turning the index plate (leaving the crankpin engaged in the hole as set in the first indexing operation) by a required amount. The difference between the amount indexed in the first and second operations results in the spindle turning the required amount for the number of divisions. Compound indexing is seldom used because (1) differential indexing is easier, (2) high-number index plates are usually available to provide any range of divisions normally required, and (3) the computation and actual operation are quite complicated, making it easy for errors to be introduced.

We will briefly describe compound indexing in the following example. To index 99 divisions proceed as follows:

1. Multiply the required number of divisions by the difference between the number of holes in two circles selected at random. Divide this product by 40 (ratio of spindle to crank) times the product of the two index hole circles. Assume you have selected the 27- and 33-hole circles. The resulting equation is

$$\frac{99 \times (33 - 27)}{40 \times 33 \times 27} \times \frac{99 \times 6}{40 \times 33 \times 27}$$

2. To make the solution easier, factor each term of the equation into its lowest prime factors and cancel where possible. For example:

$$\frac{(\cancel{3} \times \cancel{3} \times \cancel{11}) (\cancel{3} \times \cancel{2})}{(\cancel{2} \times 2 \times 2 \times 5) (\cancel{11} \times \cancel{3}) (\cancel{3} \times \cancel{3} \times 3)} = \frac{1}{60}$$

The result of this process must be in the form of a fraction as given (that is, 1 divided by some number). Always try to select the two circles that have factors that cancel out the factors in the numerator of the problem. When the numerator of the resulting fraction is greater than 1, divide it by the denominator and use the quotient (to the nearest whole number) instead of the denominator of the fraction.

3. The denominator of the resulting fraction derived in step 2 is the term used to find the number of turns and holes to index the spindle and index plate. To index for 99 divisions, turn the spindle by an amount equal to 60/33 or one complete turn plus 27 holes in the 33-hole circle; turn the index plate by an amount equal to 60/27, or two complete turns plus 6 holes in the 27-hole circle. If you turn the index crank clockwise, turn the index plate counterclockwise and vice versa.

Deleted—No permission granted for electronic copy.

## DIFFERENTIAL INDEXING

Differential indexing is similar to compound indexing except that the index plate is turned during the indexing operation by gears connected to the dividing head spindle. Because the index plate movement is caused by the spindle movement, only one indexing procedure is required. The gear train between the dividing head spindle and the index plate provides the correct ratio of movement between the spindle and the index plate.

Figure 7-18 shows a dividing head set up for differential indexing. The index crank is turned as it is for plain indexing, thus turning the spindle gear and then the compound gear and the idler to drive the gear that turns the index plate. The manufacturer's technical manuals give specific procedures to install the gearing and arrange the index plate for differential indexing (and compound indexing).

To index 57 divisions, for example, take the following steps:

1. Select a number greater or lesser than the required number of divisions for which an available index plate can be used (60 for example).

2. The number of turns for plain indexing 60 divisions is 40/60 or 14/21, which will require 14 holes in a 21-hole circle in the index plate.

3. To find the required gear ratio, subtract the required number of divisions from the selected number or vice versa (depending on which is larger), and multiply the result by 40/60 (formula to index 60 divisions). Thus:

$$\text{Gear ratio} = (60 - 57) \times \frac{40}{60} = 3 \times \frac{40}{60} = \frac{2}{1}$$

The numerator indicates the spindle gear; the denominator indicates the driven gear.

Figure 7-18.—Differential Indexing.

4. Select two gears that have a 2 to 1 ratio (for example a 48-tooth gear and a 24-tooth gear).

5. If the selected number is greater than the actual number of divisions required, use one or three idlers in the simple gear train; if the selected number is smaller, use none or two idlers. The reverse is true for compound gear trains. Since the number is greater in this example, use one or three idlers.

6. Now turn the index crank 14 holes in the 21-hole circle of the index plate. As the crank turns the spindle, the gear train turns the index plate slightly faster than the index crank.

## WIDE RANGE DIVIDER

In the majority of indexing operations, you can get the desired number of equally spaced divisions by using either direct or plain indexing. By using one or the other of these methods, you may index up to 2,640 divisions. To increase the range of divisions, use the high-number index plates in place of the standard index plate. These high-number plates have a greater number of circles of holes and a greater range of holes in the circles than the standard plates. This increases the range of possible divisions from 1,040 to 7,960.

In some instances, you may need to index beyond the range of any of these methods. To further increase the range, use a universal dividing head that has a wide range divider. This type of indexing equipment

Deleted—No permission  
granted for electronic copy.

**Figure 7-19.—The wide range divider.**

allows you to index divisions from 2 to 400,000. The wide range divider (fig. 7-19) consists of a large index plate and a small index plate, both with sector arms and a crank. The large index plate (A, fig. 7-19) has holes drilled on both sides and contains 11 circles of holes on each side of the plate. The number of holes in the circles on one side are 24, 28, 30, 34, 37, 38, 39, 41, 42, 43, and 100. The other side of the plate has circles containing 46, 47, 49, 51, 53, 54, 57, 58, 59, 62, and 66 holes. The small index plate has two circles of holes and is drilled on one side only. The outer circle has 100 holes and the inner circle has 54 holes.

The small index plate (B, fig. 7-19) is mounted on the housing of the planetary gearing (D, fig. 7-19), which is built into the index crank (F, fig. 7-19) of the large plate. As the index crank of the large plate is rotated, the planetary gearing assembly and the small index plate and crank rotate with it.

As with the standard dividing head, the large index crank rotates the spindle in the ratio of 40 to 1. Therefore, one complete turn of the large index crank rotates the dividing head spindle  $1/40$  of a turn, or  $9^\circ$ . By using the large index plate and the crank, you can index in the conventional manner. Machine operation is the same as it is with the standard dividing head.

When the small index crank (E, fig. 7-19) is rotated, the large index crank remains stationary, but the main shaft that drives the work revolves in the ratio of 1 to 100. This ratio, superimposed on the 40 to 1 ratio between the worm and worm wheel (fig. 7-20), causes the dividing head spindle to rotate in the ratio of 4,000 to 1. This means that one complete revolution of the spindle will require 4,000 turns of the small index crank. Turning the small crank one complete turn will rotate the dividing head spindle 5 minutes, 24 seconds of a degree. If one hole of the 100-hole circle on the small index plate were to



Deleted—No permission  
granted for electronic copy.

**Figure 7-20.—Section through a dividing head showing the worm, worm wheel, and worm shaft.**

be indexed, the dividing head spindle would make 1/400,000 of a turn, or 3.24 seconds of a degree.

You can get any whole number of divisions up to and including 60, and hundreds of others, by using only the large index plate and the crank. The dividing head manufacturer provides tables listing many of the settings for specific divisions that you may read directly from the table without further calculations. If the number of divisions required is not listed in the table or if there are no tables, use the manufacturer's manual or other reference for instructions on how to compute the required settings.

### **ADJUSTING THE SECTOR ARMS**

To use the index head sector arms, turn the left-hand arm to the left of the index pin, which is inserted into the first hole in the circle of holes that is to be used. Then, loosen the setscrew (C, fig. 7-19) and adjust the right-hand arm of the sector so that the correct number of holes will be contained between the two arms (fig. 7-21). After making the adjustments, lock the setscrew to hold the arms in position. When setting the arms, count the required number of holes

Deleted—No permission  
granted for electronic copy.

**Figure 7-21.—Principal parts of a late model Cincinnati universal spiral index head.**

from the one in which the pin is inserted, considering this hole as zero. Then, use the index sector and you will not need to count the holes for each division. When using the index crank to revolve the spindle, you must unlock the spindle clamp screw. However, before you cut work held in or on the index head, lock the spindle again to relieve the strain on the index pin.

## CUTTERS AND ARBORS

When you perform a milling operation, you move the work into a rotating cutter. On most milling machines, the cutter is mounted on an arbor that is driven by the spindle. However, the spindle may drive the cutter directly. We will discuss cutters in the first part of this section and arbors in the second part.

### CUTTERS

There are many different milling machine cutters. Some can be used for several operations, while others can be used for only one. Some have straight teeth and others have helical teeth. Some have mounting shanks and others have mounting holes. You must decide which cutter to use. To do so, you must be familiar with the various milling cutters and their uses. The information in this section will help you to select the proper cutter for each of the various operations you will perform. In this section we will cover cutter types and cutter selection.

Standard milling cutters are made in many shapes and sizes for milling both regular and irregular shapes. Various cutters designed for specific purposes also are available; for example, a cutter for milling a particular kind of curve on some intermediate part of the workpiece.

Milling cutters generally take their names from the operation they perform. The most common cutters are (1) plain milling cutters of various widths and diameters, used principally for milling flat surfaces that are parallel to the axis of the cutter; (2) angular milling cutters used to mill V-grooves and the grooves in reamers, taps, and milling cutters; (3) face milling cutters used to mill flat surfaces at a right angle to the axis of the cutter; and (4) forming cutters used to produce surfaces with an irregular outline.

Milling cutters may also be classified as arbor-mounted, or shank-mounted. Arbor-mounted cutters are mounted on the straight shanks of arbors. The arbor is then inserted into the milling machine spindle. We'll discuss the methods of mounting arbors and cutters in greater detail later in this chapter.

Milling cutters may have straight, right-hand, left-hand, or staggered teeth. Straight teeth are parallel to the axis of the cutter. If the helix angle twists in a clockwise direction (viewed from either end), the cutter has right-hand teeth. If the helix angle twists in a counterclockwise direction, the cutter has left-hand teeth. The teeth on staggered-tooth cutters are alternately left-hand and right-hand.

### Types and Uses

There are many different types of milling cutters. We will discuss these types and their uses in the following sections.

**PLAIN MILLING CUTTER.**—You will use plain milling cutters to mill flat surfaces that are parallel to the cutter axis. As you can see in figure 7-22, a plain milling cutter is a cylinder with teeth cut on the circumference only. Plain milling cutters are made in a variety of diameters and widths.

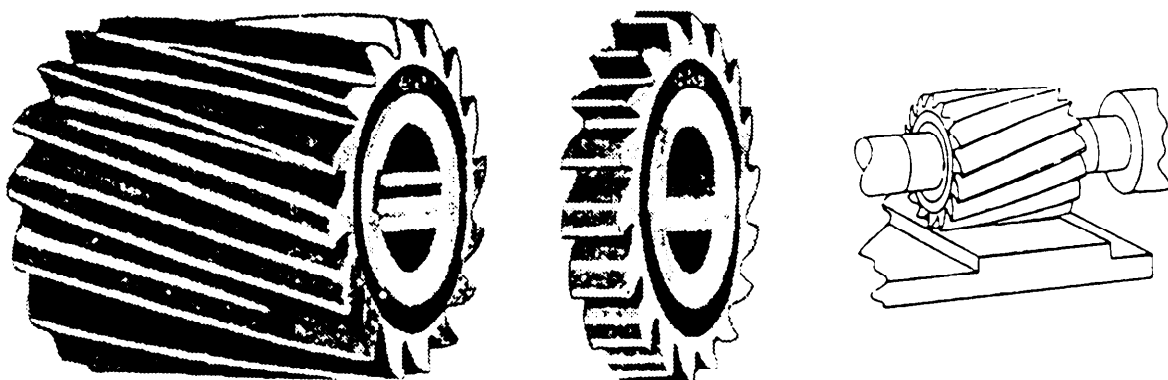


Figure 7-22.—Plain milling cutters.

Note in figure 7-23, that the cutter teeth may be either straight or helical. When the width is more than 3/4 inch, the teeth are usually helical. The teeth of a straight cutter tool are parallel to axis of the cutter. This causes each tooth to cut along its entire width at the same time, causing a shock as the tooth starts to cut. Helical teeth eliminate this shock and produce a free cutting action. A helical tooth begins the cut at one end and continues across the work with a smooth shaving action. Plain milling cutters usually have

radial teeth. On some coarse helical tooth cutters the tooth face is undercut to produce a smoother cutting action. Coarse teeth decrease the tendency of the arbor to spring and give the cutter greater strength.

A plain milling cutter has a standard size arbor hole for mounting on a standard size arbor. The size of the cutter is designated by the diameter and width of the cutter, and the diameter of the arbor hole in the cutter.

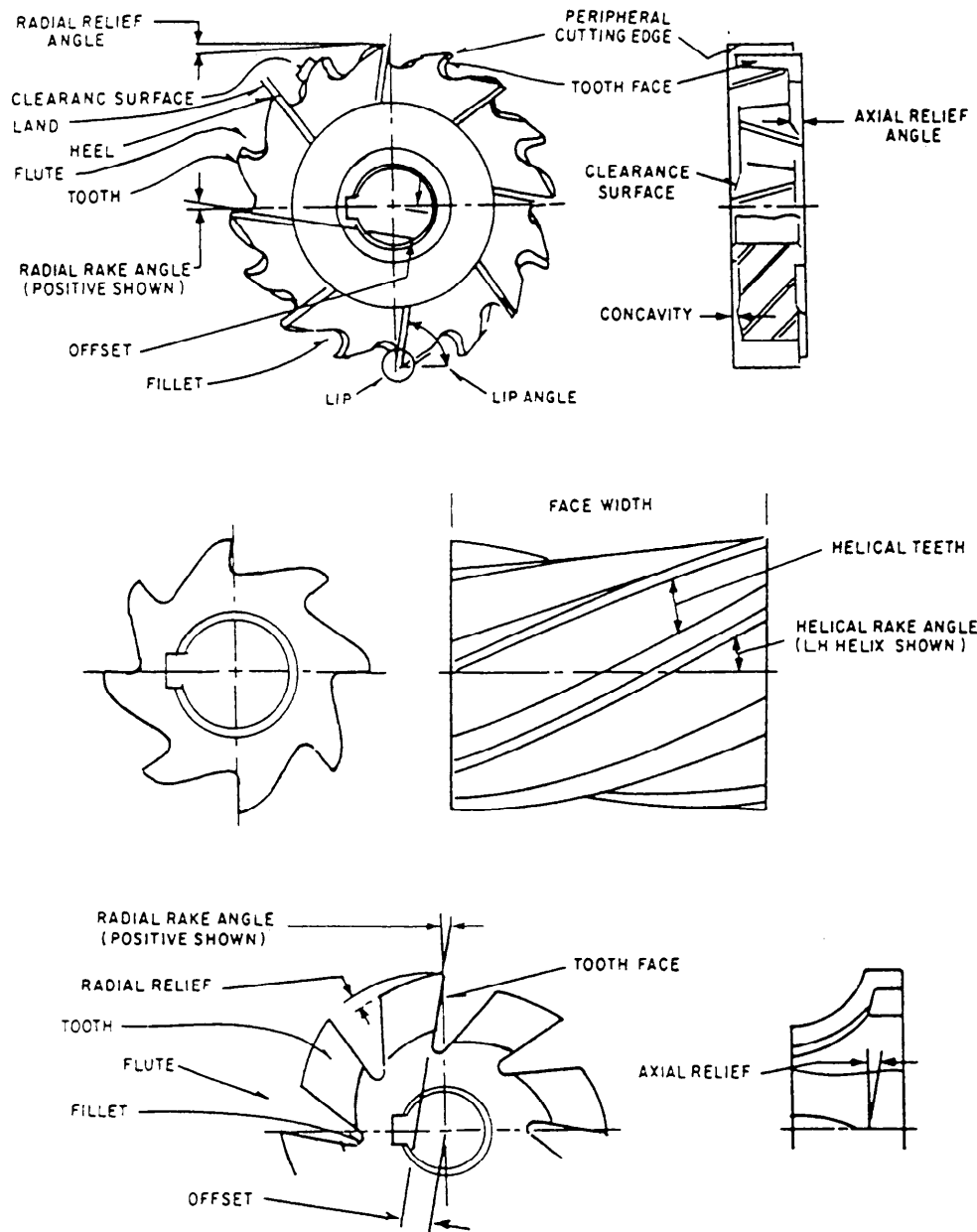


Figure 7-23.—Milling cutter terms.

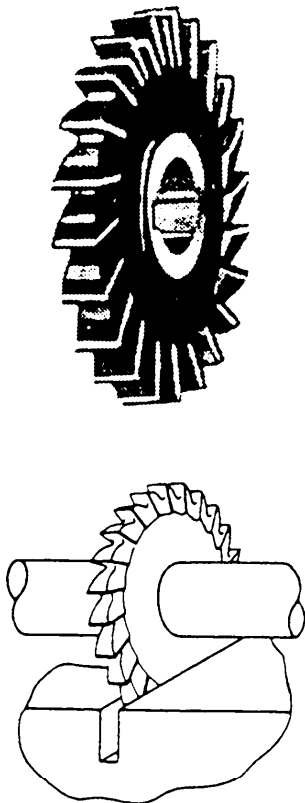


Figure 7-24.—Side milling cutter.

**SIDE MILLING CUTTER.**—The side milling cutter (fig. 7-24) is a plain milling cutter with teeth cut on both sides as well as on the periphery or circumference of the cutter. You can see that the portion of the cutter between the hub and the side of the teeth is thinner to give more chip clearance. These cutters are often used in pairs to mill parallel sides. This process is called straddle milling. Cutters more than 8 inches in diameter are usually made with inserted teeth. The size designation is the same as for plain milling cutters.

**HALF-SIDE MILLING CUTTER.**—Half-side milling cutters (fig. 7-25) are made particularly for jobs where only one side of the cutter is needed. These cutters have coarse, helical teeth on one side only so that heavy cuts can be made with ease.

**SIDE MILLING CUTTER (INTERLOCKING).**—Side milling cutters whose teeth interlock (fig. 7-26) can be used to mill standard size slots. The width is regulated by thin washers inserted between the cutters.

**METAL SLITTING SAW.**—You can use a metal slitting saw to cut off work or to mill narrow slots. A metal slitting saw is similar to a plain or side milling cutter, with a face width usually less than 3/16 inch. This type of cutter usually has more teeth for a given diameter than a plain cutter. It is thinner at the



Figure 7-25.—Half-side milling cutter.

center than at the outer edge to give proper clearance for milling deep slots. Figure 7-27 shows a metal slitting saw with teeth cut in the circumference of the cutter only. Some saws, such as the one in figure 7-28, have side teeth that achieve better cutting action, break up chips, and prevent dragging when you cut deep slots. For heavy sawing in steel, there are metal slitting saws with staggered teeth, as shown in figure 7-29. These cutters are usually 3/16 inch to 3/8 inch thick

**SCREW SLOTTING CUTTER.**—The screw slotting cutter (fig. 7-30) is used to cut shallow slots, such as those in screwheads. This cutter has fine teeth cut on its circumference. It is made in various thicknesses to correspond to American Standard gauge wire numbers.

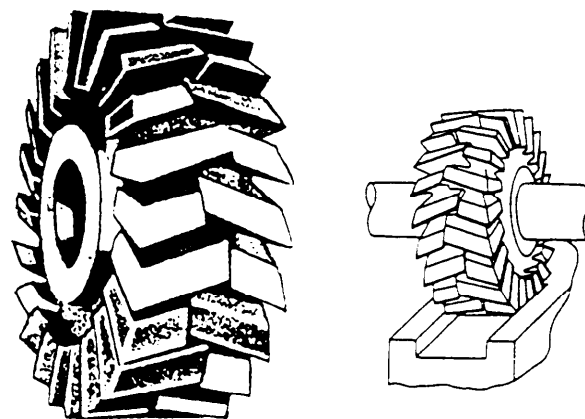


Figure 7-26.—Interlocking teeth side milling cutter.



Figure 7-27.—Metal slitting saw.

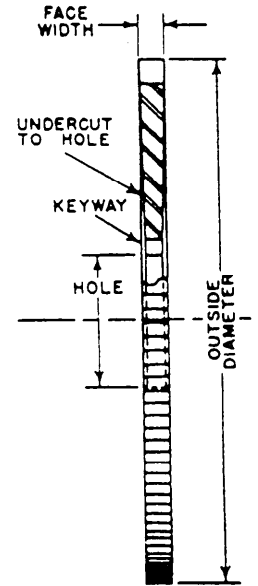
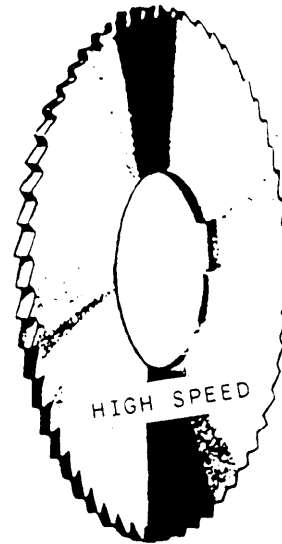


Figure 7-30.—Screw slotting cutter.

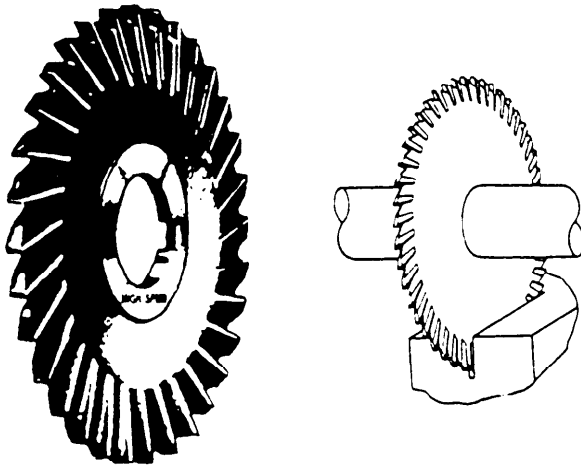


Figure 7-28.—Slitting saw with side teeth.

**ANGLE CUTTER.**—Angle cutters are used to mill surfaces that are not at a right angle to the cutter axis. You can use angle cutters for a variety of work, such as milling V-grooves and dovetail ways. On work such as dovetailing, where you cannot mount a cutter in the usual manner on an arbor, you can mount an angle cutter that has a threaded hole, or is constructed like a shell end mill, on the end of a stub or shell end mill arbor. When you select an angle cutter for a job, you should specify the type, hand, outside diameter, thickness, hole size, and angle.

There are two types of angle cutters—single and double. The single-angle cutter, shown in figure 7-31, has teeth cut at an oblique angle with one side at an

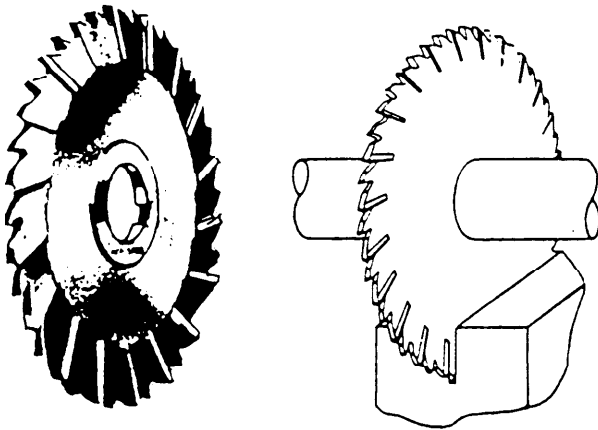


Figure 7-29.—Slitting saw with staggered teeth.

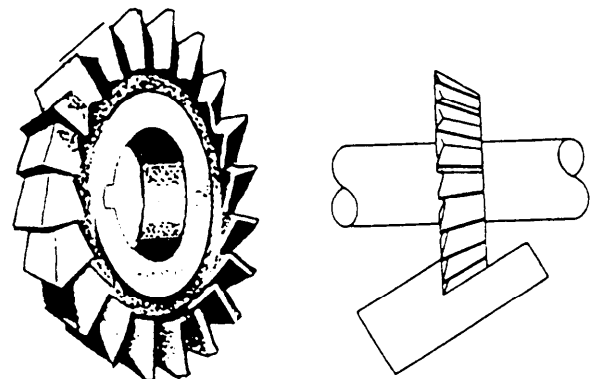


Figure 7-31.—Single-angle cutter.

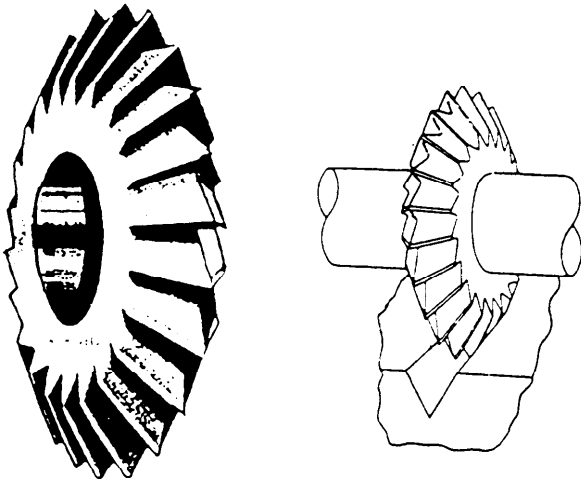
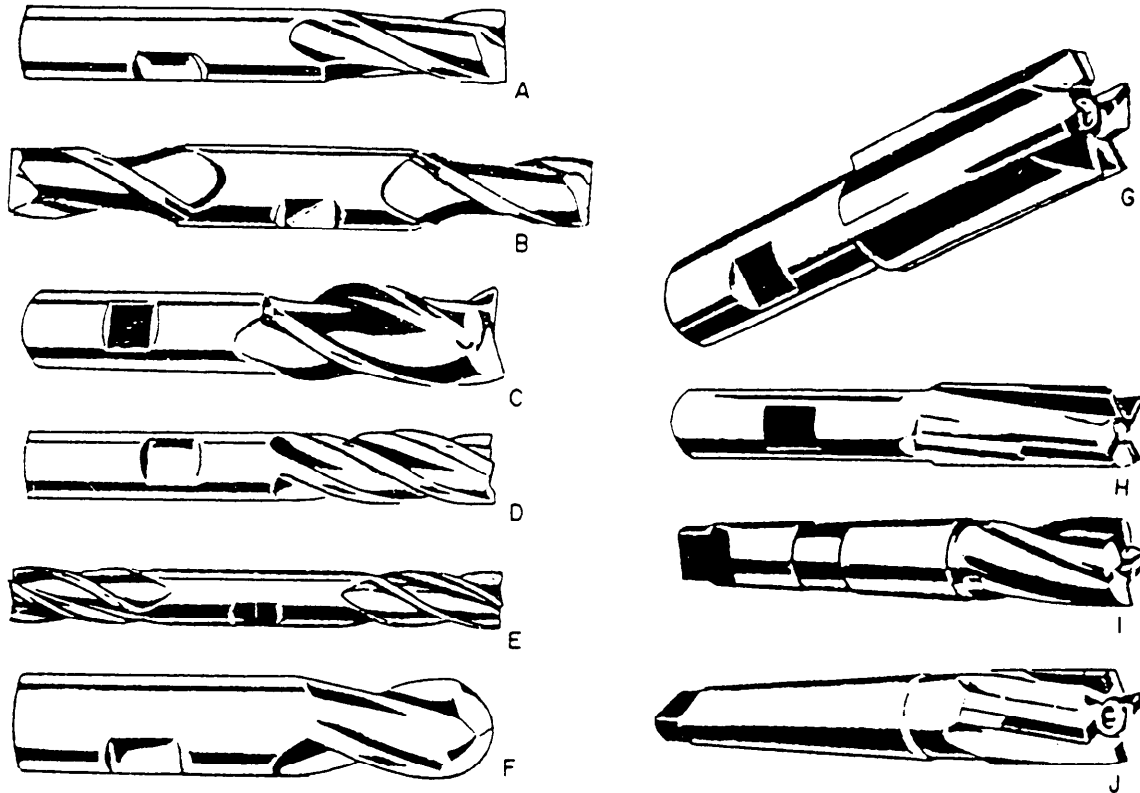


Figure 7-32.—Double-angle cutter.

angle of  $90^\circ$  to the cutter axis and the other usually at  $45^\circ$ ,  $50^\circ$ , or  $80^\circ$ .

The double-angle cutter (fig. 7-32) has two cutting faces, which are at an angle to the cutter axis. When both faces are at the same angle to the axis, you obtain the cutter you want by specifying the included angle. When they are different angles, you specify the angle of each side with respect to the plane of intersection.

**END MILL CUTTERS.**—End mill cutters may be the **SOLID TYPE** with the teeth and the shank as an integral part (fig. 7-33), or they may be the **SHELL TYPE** (fig. 7-34) in which the cutter body and the shank or arbor are separate. End mill cutters have teeth on the circumference and on the end. Those on the circumference may be either straight or helical (fig. 7-35).



- A. Two-flute single-end
- B. Two-flute double-end
- C. Three-flute single-end
- D. Multiple-flute single-end
- E. Four-flute double-end

- F. Two-flute ball-end
- G. Carbide-tipped, straight flutes
- H. Carbide-tipped, right-hand helical flutes
- I. Multiple-flute with taper shank
- J. Carbide-tipped with taper shank and helical flutes

Figure 7-33.—End mill cutters.

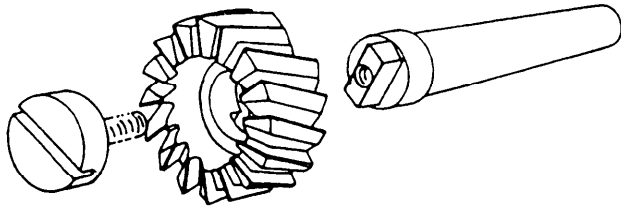


Figure 7-34.—Shell end mill.

Except for the shell type, all end mills have either a straight shank or a tapered shank is mounted into the spindle of the machine to drive the cutter. There are various types of adapters used to secure end mills to the machine spindle.

End milling involves the machining of surfaces (horizontal, vertical, angular, or irregular) with end

STANDARD  
MILLING CUTTERS AND END MILLS

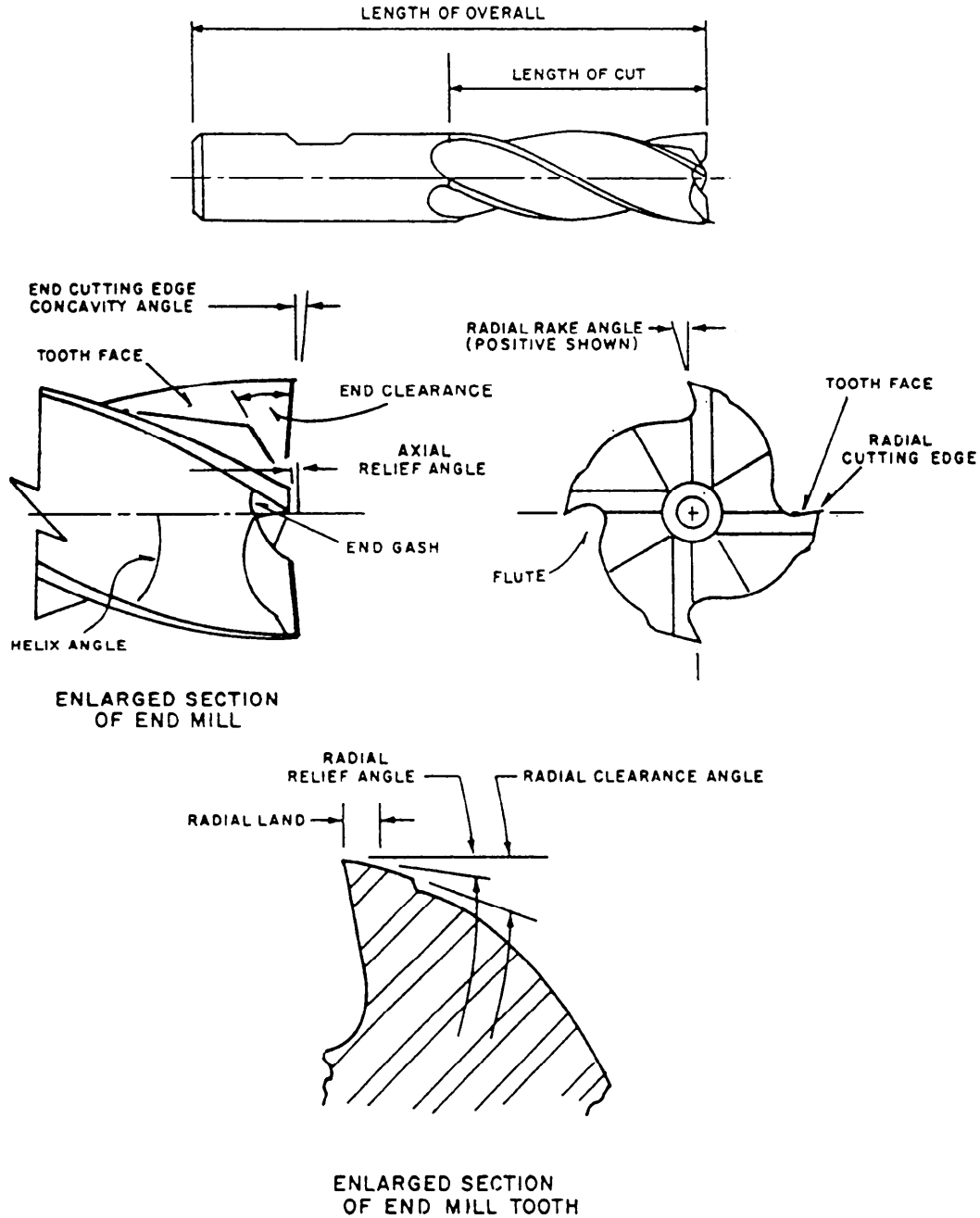


Figure 7-35.—End mill terms.

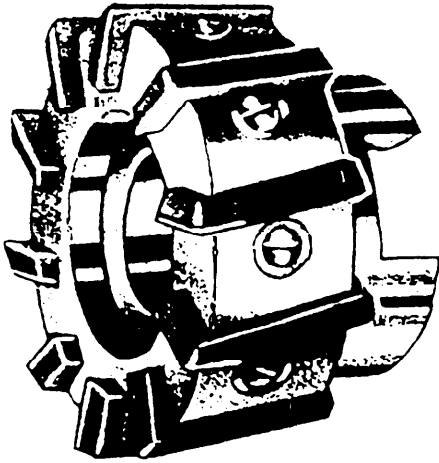


Figure 7-36.—Inserted tooth face milling cutter.

mill cutters. Common operations include the milling of slots, keyways, pockets, shoulders, and flat surfaces, and the profiling of narrow surfaces.

End mill cutters are used most often on vertical milling machines. However, they also are used frequently on machines with horizontal spindles. Many different types of end mill cutters are available in sizes ranging from 1/64 inch to 2 inches. They may be made of high-speed steel, have cemented carbide teeth, or be of the solid carbide type.

**TWO-FLUTE END MILLS** have only two teeth on their circumference. The end teeth can cut to the center. Hence, they may be fed into the work like a drill; they can then be fed lengthwise to form a slot.

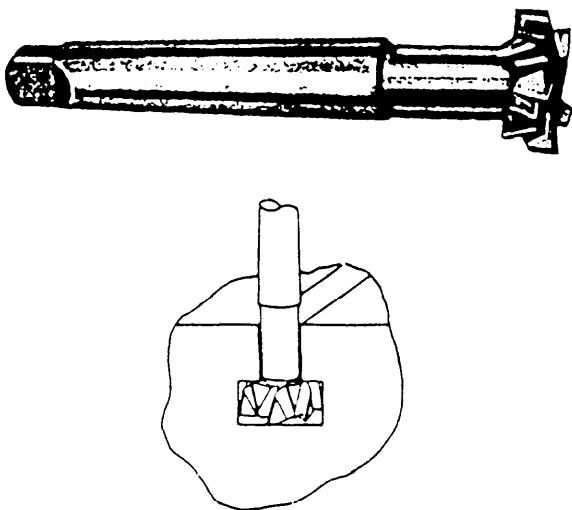


Figure 7-37.—T-slot cutter.

These mills may be either the single-end type with the cutter on one end only, or they may be the double-end type. (See fig. 7-33.)

**MULTIPLE-FLUTE END MILLS** have three, four, six, or eight flutes and normally are available in diameters up to 2 inches. They may be either the single-end or the double-end type (fig. 7-33).

**BALL END MILLS** (fig. 7-33) are used to mill fillets or slots with a radius bottom, to round pockets and the bottom of holes, and for all-around die sinking and die making work. Two-flute end mills with end cutting lips can be used to drill the initial hole as well as to feed longitudinally. Four-flute ball end mills with center cutting lips also are available. These work well for tracer milling, fillet milling, and die sinking.

**SHELL END MILLS** (fig. 7-34) have a hole used to mount the cutter on a short (stub) arbor. The center of the shell is recessed for the screw or nut that fastens the cutter to the arbor. These mills are made in larger sizes than solid end mills, normally in diameters from 1/4 to 6 inches. Cutters of this type are intended for slabbing or surfacing cuts, either face milling or end milling, and usually have helical teeth.

**FACE MILLING CUTTER.**—Inserted tooth face milling cutters (fig. 7-36) are similar to shell end mills in that they have teeth on the circumference and on the end. They are attached directly to the spindle nose and use inserted, replaceable teeth made of carbide or any alloy steel.

**T-SLOT CUTTER.**—The T-slot cutter (fig. 7-37) is a small plain milling cutter with a shank. It is

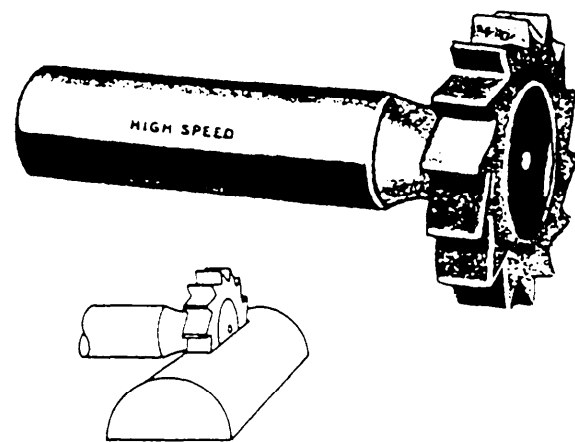


Figure 7-38.—Woodruff keyseat cutter.



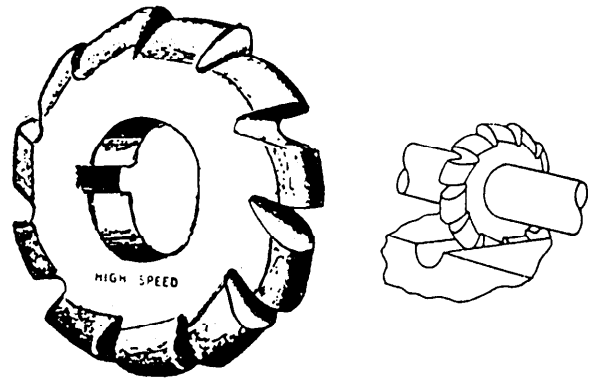
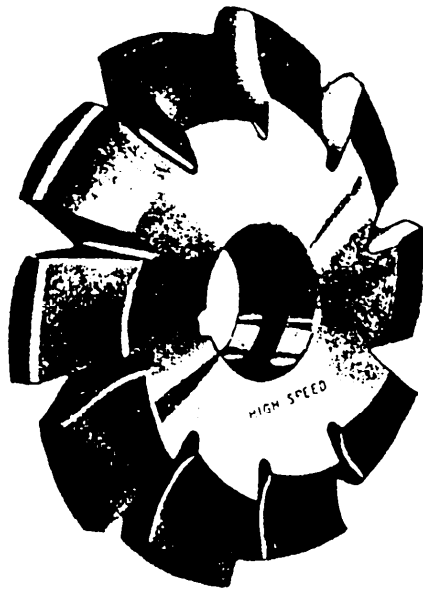


Figure 7-41.—Convex cutter.

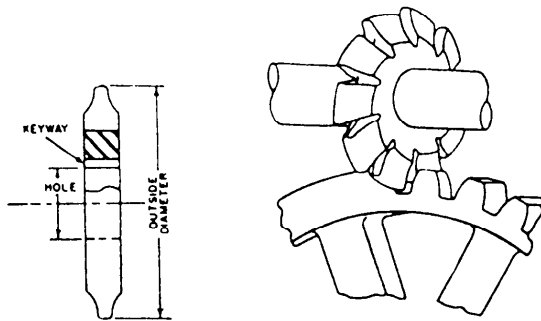


Figure 7-39.—Involute gear cutter.

designed especially to mill the “head space” of T-slots. T-slots are cut in two operations. First, you cut a slot with an end mill or a plain milling cutter, and then you make the cut at the bottom of the slot with a T-slot cutter.

**WOODRUFF KEYSEAT CUTTER.**—A Woodruff keyseat cutter (fig. 7-38) is used to cut curved keyseats. A cutter less than 1/2 inch in diameter has a shank. When the diameter is greater than 1/2 inch, the cutter is usually mounted on an arbor. The larger cutters have staggered teeth to improve the cutting action.

**GEAR CUTTERS.**—There are several types of gear cutters, such as bevel, spur, involute, and so on. Figure 7-39 shows an involute gear cutter. You must select the correct cutter for a particular type of gear.

**CONCAVE AND CONVEX CUTTERS.**—A concave cutter (fig. 7-40) is used to mill a convex surface, and a convex cutter (fig. 7-41) is used to mill a concave surface.

**CORNER ROUNDING CUTTER.**—Corner rounding cutters (fig. 7-42) are formed cutters that are used to round corners up to one-quarter of a circle.



Figure 7-40.—Concave cutter.

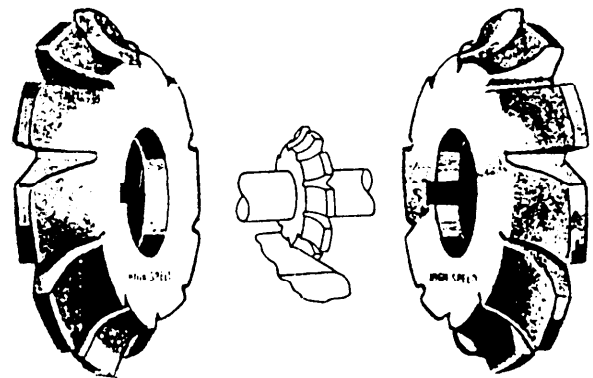


Figure 7-42.—Corner rounding cutter.

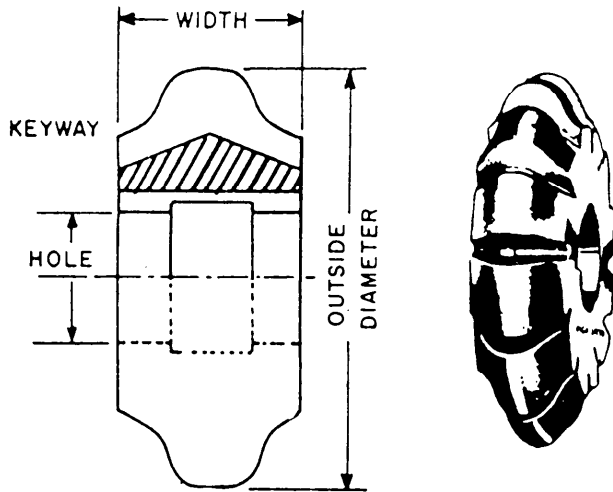


Figure 7-43.—Sprocket wheel cutter.

**SPROCKET WHEEL CUTTER.**—The sprocket wheel cutter (fig. 7-43) is a formed cutter that is used to mill teeth on sprocket wheels.

**GEAR HOB.**—The gear hob (fig. 7-44) is a formed milling cutter with teeth cut like threads on a screw.

**FLY CUTTER.**—The fly cutter (fig. 7-45) is often manufactured locally. It is a single-point cutting tool similar in shape to a lathe or shaper tool. It is held and rotated by a fly cutter arbor. There will be times when you need a special formed cutter for a very limited number of cutting or boring operations. This will probably be the type of cutter you will use since you can grind it to almost any form you need.

We have discussed a number of the more common types of milling machine cutters. For a more detailed discussion of these, other types, and their uses, consult the *Machinery's Handbook*, machinist publications, or the applicable technical manual. We will now discuss the selection of cutters.

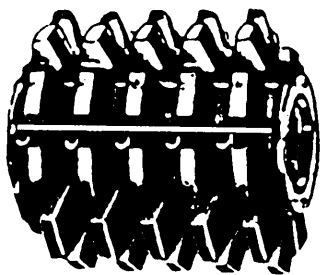


Figure 7-44.—Gear hob.

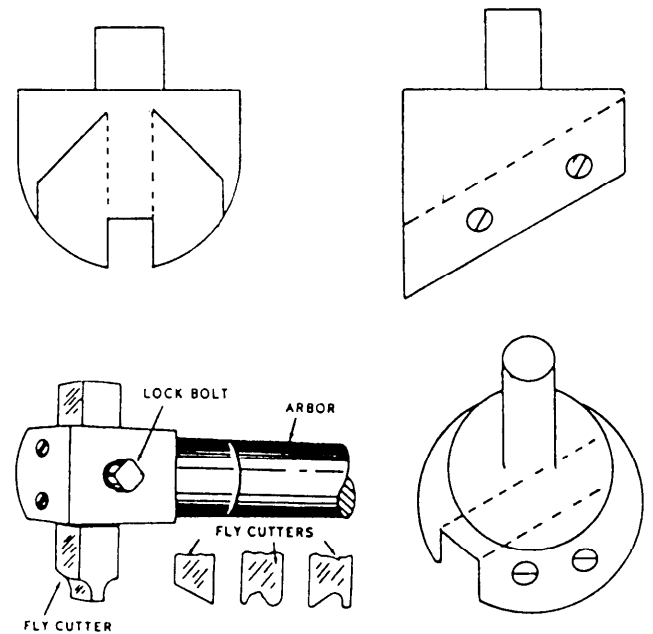


Figure 7-45.—Fly cutter arbor and fly cutters.

### Selection

Each cutter can do one kind of job better than any other cutter in a given situation. A cutter may or may not be limited to a specific milling operation. To select the most suitable cutter for a particular operation, you must consider the kind of cut to be made, the material to be cut, the number of parts to be machined, and the type of milling machine available.

Another factor that affects a milling operation is the number of teeth in the cutter. If there are too many teeth, the space between them is so small that it prevents the free flow of chips. The chip space should also be smooth and free of sharp corners to prevent the chips from clogging the space. A coarse-tooth cutter is more satisfactory for milling material that produces a continuous and curled chip. The coarse teeth not only permit an easier flow of chips and coolant but also help to eliminate chatter. A fine-tooth cutter is more satisfactory for milling a thin material. It reduces cutter and workpiece vibration and the tendency for the cutter teeth to “straddle” the work and dig in.

Another factor you should consider in selecting a cutter is its diameter. Select the smallest diameter cutter that will allow the arbor to pass over the work without interference when you take the cut. Figure 7-46 shows that a small cutter takes a cut in less time than a larger cutter.

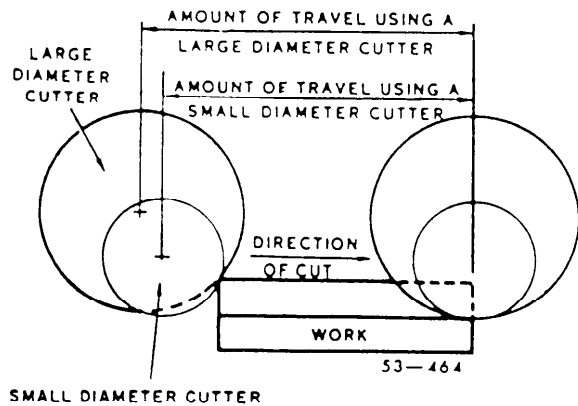


Figure 7-46.—Cutter diameter selection.

## ARBORS

You can mount milling machine cutters on several types of holding devices. You must know the devices and the purpose of each of them to make the most suitable tooling setup for the operation. We will cover the various types of arbors and the mounting and dismounting of arbors in this section.

**NOTE:** Technically, an arbor is a shaft on which a cutter is mounted. For convenience, since there are so few types of cutter holders that are not arbors, we will refer to all types of cutter holding devices as arbors.

### Standard Arbor

There are several types of milling machine arbors. You will use the common or standard types (fig. 7-47) to hold and drive cutters that have mounting holes. One end of the arbor usually has a standard milling

machine spindle taper of 3 1/2 inches per foot. The largest diameter of the taper is identified by a number. For example, the large diameter of a No. 40 milling machine spindle taper is 1 3/4 inches. The following numbers represent common milling machine spindle tapers and their sizes:

<u>Number</u>	<u>Large Diameter</u>
10	5/8 inch
20	7/8 inch
30	1 1/4 inch
40	1 3/4 inches
50	2 3/4 inches
60	4 1/4 inches

Standard arbors are available in styles A and B, as shown in figure 7-47. Style A arbors have a pilot-type bearing usually 1 1/32 inch in diameter. Style B arbors have a sleeve-type outboard bearing. Numerals identify the outside diameter of the bearing sleeves, as follows:

<u>Sleeve Number</u>	<u>Outside Diameter</u>
3	1 7/8 inches
4	2 1/8 inches
5	2 3/4 inches

The inside diameter can be any one of several standard diameters that are used for the arbor shaft.

Style A arbors sometimes have a sleeve bearing that permits the arbor to be used as either a style A or a style B arbor. A code system, consisting of numerals and a letter, identifies the size and style of the arbor. The code number is stamped into the flange

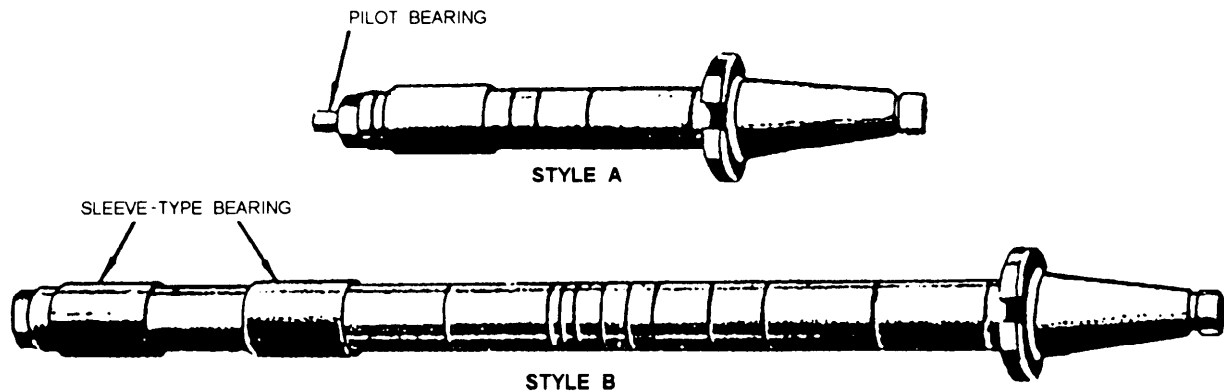


Figure 7-47.—Standard milling machine arbors.

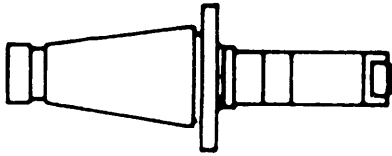


Figure 7-48.—Stub arbor.

or on the tapered portion of the arbor. The first number of the code identifies the diameter of the taper. The second (and if used, the third number) identifies the diameter of the arbor shaft. The letter identifies the type of bearing. The numbers following the letter identifies the usable length of the arbor shaft. Sometimes an additional number is used to identify the size of the sleeve-type bearings. The meaning of a typical code number 5-1¼-A-18-4 is as follows:

- 5 = taper number—50 (the 0 is omitted in the code)
- 1¼ = shaft diameter—1¼ inches
- A = style A bearing—pilot type
- 18 = usable shaft length—18 inches
- 4 = bearing size—2 1/8 inches diameter

### Stub Arbor

Arbors that have very short shafts, such as the one shown in figure 7-48, are called stub arbors. Use stub arbors when it is impractical to use a longer arbor.

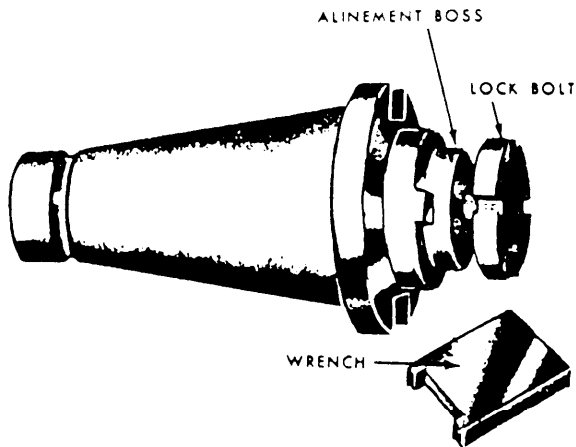


Figure 7-49.—Shell end mill arbor.

You will use arbor spacing collars of various lengths to position and secure the cutter on the arbor. Tighten the spacers against the cutter when you tighten the nut on the arbor. Remember, never tighten or loosen the arbor nut unless the arbor support is in place.

### Shell End Arbor

Shell end mill arbors (fig. 749) are used to hold and drive shell end mills. The shell end mill is fitted over the short boss on the arbor shaft. It is driven by two keys and is held against the face of the arbor by a bolt. Use a special wrench, shown in figure 7-48, to tighten and loosen the bolt. Shell end mill arbors are identified by a code similar to the standard arbor code. The letter *C* identifies a shell end mill arbor. A typical shell mill arbor code 4-1½-C-7/8 is identified as follows:

- 4 = taper code number—40
- 1½ = diameter of mounting hole in end mill—1½ inches
- C = style C arbor—shell end mill
- 7/8 = length of shaft—7/8 inch

### Fly Cutter Arbor

Fly cutter arbors are used to hold single-point cutters. These cutters (fig. 7-45) can be ground to any desired shape and held in the arbor by a locknut. Fly cutter arbor shanks may have a standard milling machine spindle taper, a Brown and Sharpe taper, or a Morse taper.

### Screw Slotting Cutter Arbor

Screw slotting cutter arbors are used with screw slotting cutters. The flanges support the cutter and prevent it from flexing. The shanks on screw slotting cutter arbors may be straight or tapered, as shown in figure 7-50.

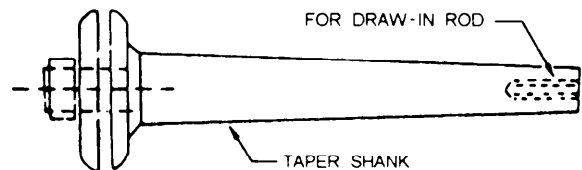


Figure 7-50.—Screw slotting cutter arbor.

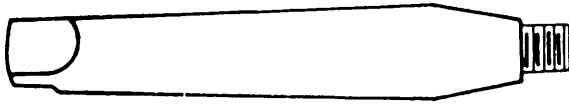


Figure 7-51.—Screw arbor.

### Screw Arbor

Screw arbors (fig. 7-51) are used with cutters that have threaded mounting holes. The threads may be left- or right-hand.

### Taper Adapter

Taper adapters are used to hold and drive taper-shanked tools, such as drills, drill chucks, reamers, and end mills. You insert the tool into the tapered hole in the adapter. The code for a taper adapter includes the number representing the standard milling machine spindle taper and the number and series of the internal taper. For example, the taper adapter code number 43M means:

4 = taper identification number—40

3M = internal taper—number 3 Morse

If a letter is not included in the code number, the taper is understood to be a Brown and Sharpe. For example, 57 means:

5 = taper number—50

7 = internal taper—number 7 B and S

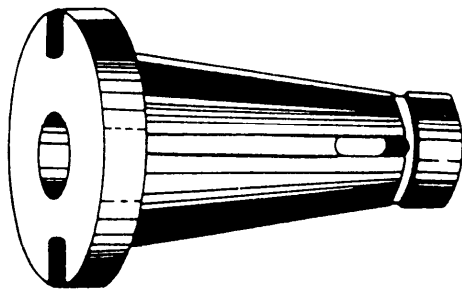


Figure 7-52.—Taper adapter.

and 50-10 means:

50 = taper identification number

10 = internal taper—number 10 B and S

Figure 7-52 shows a typical taper adapter. Some cutter adapters are designed to be used with tools that have taper shanks and a cam locking feature. The cam lock adapter code indicates the number of the external taper, number of the internal taper (which is usually a standard milling machine spindle taper), and the distance that the adapter extends from the spindle of the machine. For example, 50-20-3 5/8 inches means:

50 = taper identification number (external)

20 = taper identification number (internal)

3 5/8 = distance adapter extends from spindle is 3 5/8 inches

### Cutter Adapter

Cutter adapters, such as the one shown in figure 7-53, are similar to taper adapters except they always have straight, rather than tapered, holes. They are used to hold straight shank drills, end mills, and so forth. The cutting tool is secured in the adapter by a setscrew. The code number indicates the number of the taper and the diameter of the hole. For example, 50-5/8 means the adapter has a number 50 taper and a 5/8-inch-diameter hole.

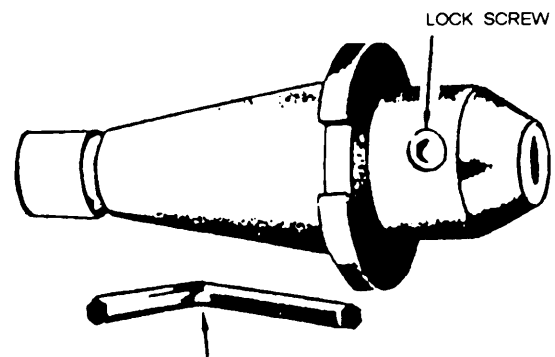


Figure 7-53.—Cutter adapter.

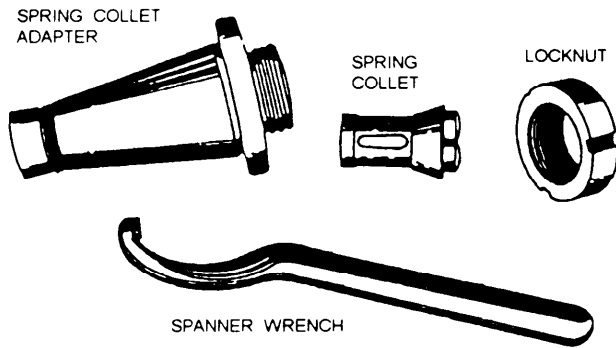


Figure 7-54.—Spring collet chuck adapter.

## Spring Collet Chuck

Spring collet chucks (fig. 7-54) are used to hold and drive straight-shanked tools. The spring collet chuck consists of a collet adapter, spring collets, and a cup nut. Spring collets are similar to lathe collets. The cup forces the collet into the mating taper, causing the collet to close on the straight shank of the tool. The collets are available in several fractional sizes.

## MILLING MACHINE OPERATIONS

The milling machine is one of the most versatile metalworking machines. It can be used for simple operations, such as milling a flat surface or drilling a hole, or more complex operations, such as milling helical gear teeth. It would be impractical to try to discuss all of its operations. Therefore, we'll limit our discussion to plain, face, and angular milling; milling flat surfaces on cylindrical work, slotting, parting, and milling keyseats and flutes; and drilling, reaming, and boring. Even though we will discuss only the more common operations, you will find that by using a combination of operations, you will be able to produce a variety of work projects.

## PLAIN MILLING

Plain milling is the process of milling a flat surface in a plane parallel to the cutter axis. You get the work to its required size by individually milling each of the flat surfaces on the workpiece. You'll use plain milling cutters such as those shown in figure 7-22. If possible, select a cutter that is slightly wider than the width of the surface to be milled. Make the work setup before you mount the cutter; this may prevent cuts on your hands caused by striking the cutter. You can mount the work in a vise or fixture, or

clamp it directly to the milling machine table. You can use the same methods that you used to hold work in a shaper. Clamp the work as closely as possible to the milling machine column so you can mount the cutter near the column. The closer you place the cutter and the work to the column, the more rigid the setup will be.

The following steps explain how to machine a rectangular work blank (for example, a spacer for an engine test stand):

1. Mount the vise on the table and position the vise jaws parallel to the table length.

**NOTE:** The graduations on the vise are accurate enough because we are concerned only with machining a surface in a horizontal plane.

2. Place the work in the vise, as shown in view A, figure 7-55.
3. Select the proper milling cutter and arbor.
4. Wipe off the tapered shank of the arbor and the tapered hole in the spindle with a clean cloth.
5. Mount the arbor in the spindle.
6. Clean and position the spacing collars and place them on the arbor so that the cutter is above the work.
7. Wipe off the milling cutter and any additional spacing collars that may be needed. Then, place the cutter, the spacers, and the arbor bearing on the arbor, with the cutter keyseat aligned over the key. Locate the bearing as

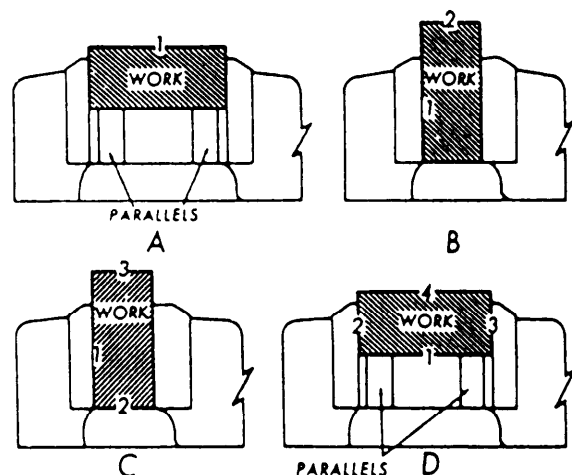


Figure 7-55.—Machining sequence to square a block.

closely as possible to the cutter. Make sure that the work and the vise will clear all parts of the machine.

8. Install the arbor nut and tighten it finger tight only.
9. Position the overarm and mount the arbor support.
10. After supporting the arbor, tighten the arbor nut with a wrench.
11. Set the spindle directional control lever to give the required direction of cutter rotation.
12. Determine the required speed and feed, and set the spindle speed and feed controls.
13. Set the feed trip dogs for the desired length of cut and center the work under the cutter.
14. Lock the saddle.
15. Engage the spindle clutch and pick up the cut.
16. Pick up the surface of the work by holding a long strip of paper between the rotating cutter and the work; very slowly move the work toward the cutter until the paper strip is pulled between the cutter and the work. Keep your fingers away from the cutter. A rotating milling cutter is very dangerous.
17. Move the work longitudinally away from the cutter and set the vertical feed graduated collar at ZERO.
18. Compute the depth of the roughing cut and raise the knee this distance.
19. Lock the knee, and direct the coolant flow on the work and on the outgoing side of the cutter.
20. Position the cutter to within 1/16 inch of the work, using hand table feed.
21. Engage the power feed.
22. After completing the cut, stop the spindle.
23. Return the work to its starting point on the other side of the cutter.
24. Raise the table the distance required for the finish cut.
25. Set the finishing speed and feed, and take the finish cut.

26. When you have completed the operation, stop the spindle and return the work to the opposite side of the cutter.

27. Deburr the work and remove it from the vise.

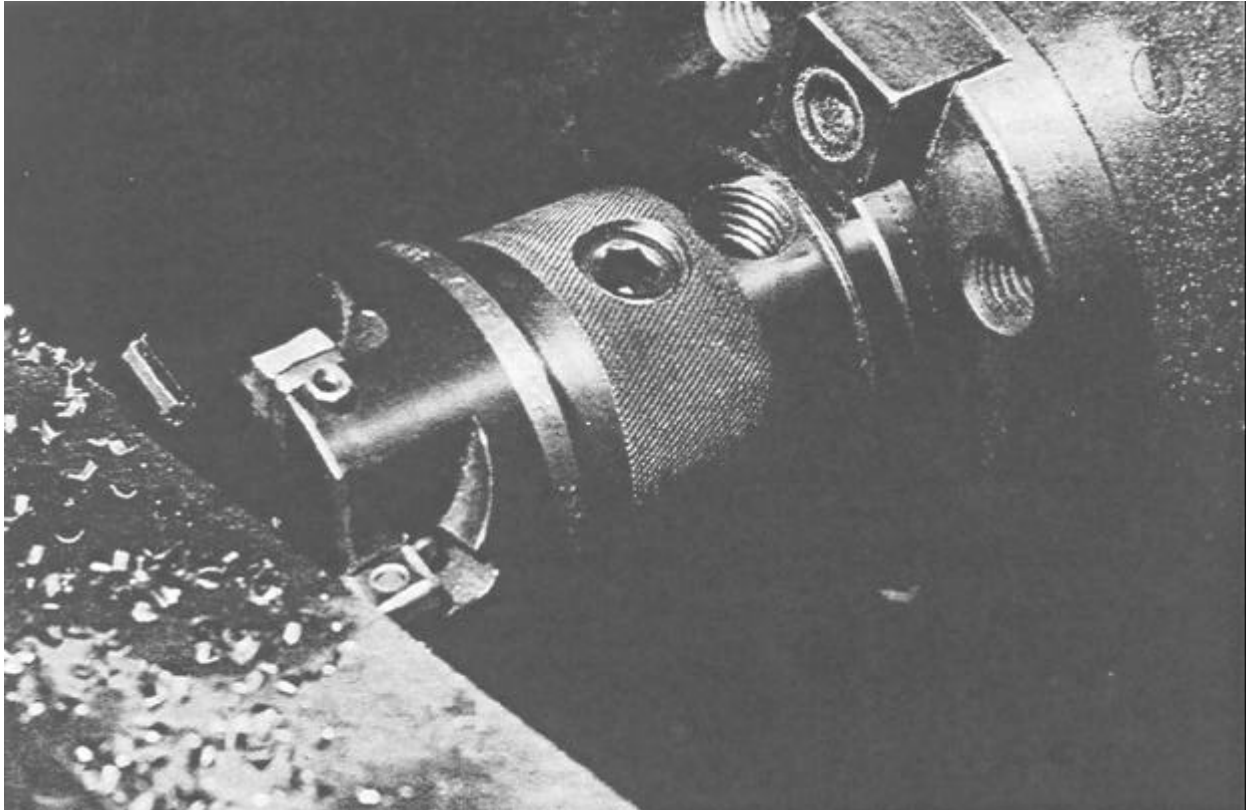
To machine the second side, place the work in the vise as shown in figure 7-55, view B. Rough and finish machine side 2, using the same procedures that you used for side 1. When you have completed side 2, deburr the surface and remove the work from the vise.

Place the work in the vise, as shown in figure 7-55, view C, with side 3 up. Then, rough machine side 3. Finish machine side 3 for a short distance, disengage the spindle and feed, and return the work to the starting point, clear of the cutter. Now you can safely measure the distance between sides 2 and 3. If this distance is correct, you can continue the cut with the same setting. If it is not, adjust the depth of cut as necessary. If the trial finishing cut is not deep enough, raise the work slightly and take another trial cut. If the trial cut is too deep, you will have to remove the backlash from the vertical feed before taking the new depth of cut. Use the following procedure to remove the backlash:

1. Lower the knee well past the original depth of the roughing cut.
2. Raise the knee the correct distance for the finishing cut.
3. Engage the feed and complete your cut.
4. Stop the spindle.
5. Return the work to the starting point on the other side of the cutter.
6. Deburr the work.
7. Remove the work from the vise.

Place side 4 in the vise, as shown in figure 7-55, view D, and machine the side, using the same procedure as for side 3. When you have completed side 4, remove the work from the vise and check it for accuracy.

This completes the machining of the four sides of the block. If the block is not too long, you can rough and finish mill the ends to size in the same manner in which you milled the sides. Do this by placing the block on end in the vise. You also may use face milling to machine the ends.



28.402

Figure 7-56.—Face milling.

## FACE MILLING

Face milling is the milling of surfaces that are perpendicular to the cutter axis, as shown in figure 7-56. Use this method to produce flat surfaces and to machine work to the required length. In face milling, the feed can be either horizontal or vertical.

### Cutter Setup

You can use straight-shank or taper-shank end mills, shell end mills, or face milling cutters for face milling. Select a cutter that is slightly larger in diameter than the thickness of the material you are machining. If the cutter is smaller in diameter than the thickness of the material, you will be forced to make a series of slightly overlapping cuts to machine the entire surface. Mount the arbor and the cutter before you make the work setup. Mount the cutter by any means suitable for the cutter you selected.

### Work Setup

Use any suitable means to hold the work for face milling as long as the cutter clears the workholding device and the milling machine table. You can mount the work on parallels, if necessary, to provide clearance between the cutter and the table. Feed the work from the side of the cutter that will cause the cutter thrust to force the work down. If you hold the work in a vise, position the vise so the cutter thrust is toward the solid jaw. The ends of the work are usually machined square to the sides of the work; therefore, you'll have to align the work properly. If you use a vise to hold the work, you can align the stationary vise jaw with a dial indicator, as shown in figure 7-57. You can also use a machinist's square and a feeler gauge, as shown in figure 7-58.

### Operation

Use the following procedure to face mill the ends of work:

1. Select and mount a suitable cutter.



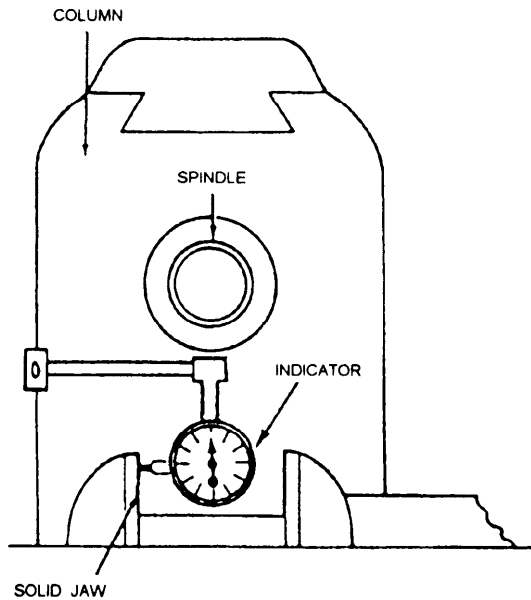


Figure 7-57.—Aligning vise jaws using an indicator.

2. Mount and position a vise on the milling machine table so the thrust of the cutter is toward the solid vise jaw.
3. Align the solid vise jaw square with the column of the machine, using a dial indicator for accuracy.
4. Mount the work in the vise, allowing the end of the work to extend slightly beyond the vise jaws.
5. Raise the knee until the center of the work is approximately even with the center of the cutter.

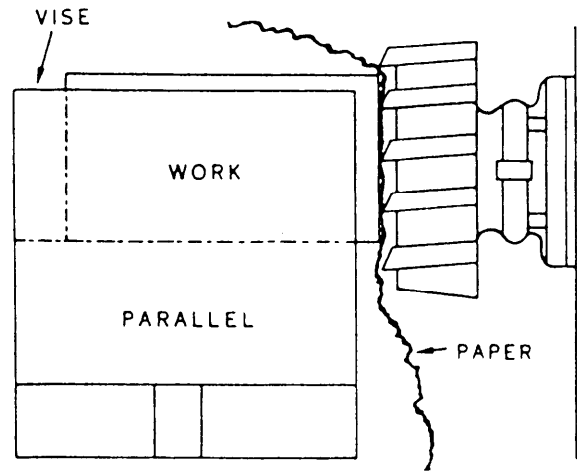


Figure 7-59.—Picking up the work surface.

6. Lock the knee in position.
7. Set the machine for the proper roughing speed, feed, and table travel.
8. Start the spindle and pick up the end surface of the work by hand feeding the work toward the cutter.
9. Place a strip of paper between the cutter and the work, as shown in figure 7-59, to help pick up the surface. When the cutter picks up the paper there is approximately 0.003-inch clearance between the cutter and the material being cut.
10. Once the surface is picked up, set the saddle feed graduated dial at ZERO.

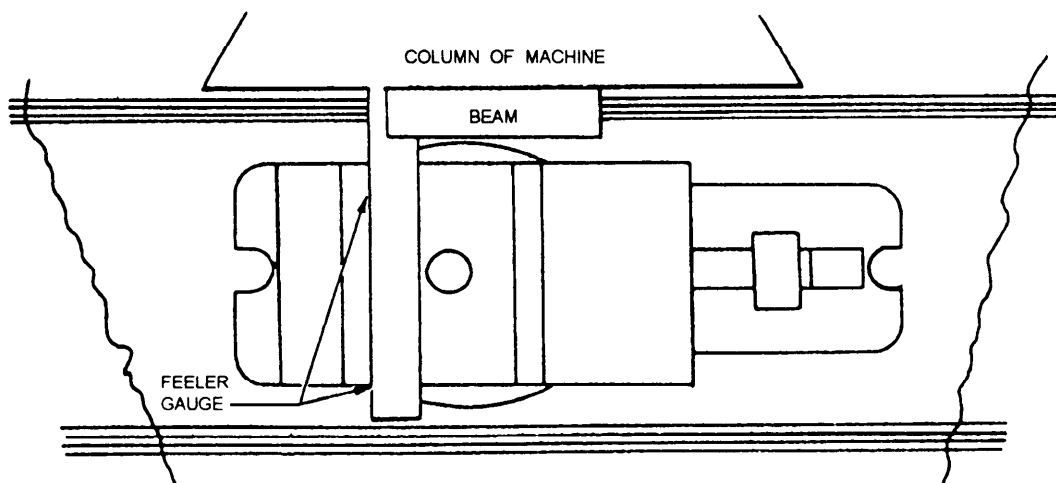


Figure 7-58.—Aligning vise jaws using a square.

## ANGULAR MILLING

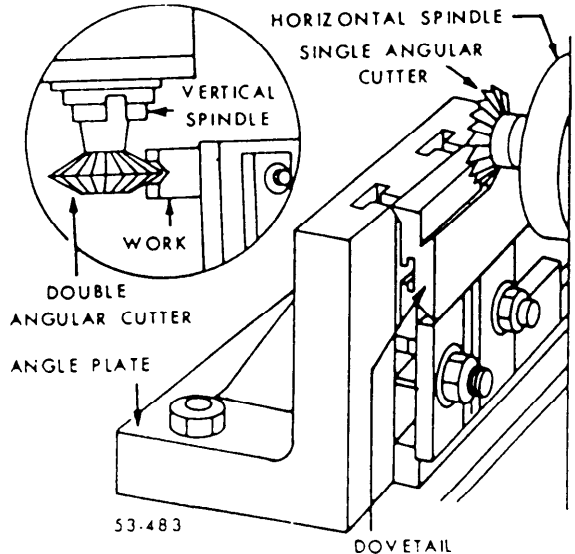


Figure 7-60.—Angular milling.

11. Move the work away from the cutter with the table and direct the coolant flow onto the cutter.
12. Set the roughing depth of cut, using the graduated dial, and lock the saddle.
13. Position the work to about 1/16 inch from the cutter, and then engage the power feed.
14. After completing the cut, stop the spindle, and move the work back to the starting point before the next cut.
15. Set the speed and feed for the finishing cut, and then unlock the saddle.
16. Move the saddle in for the final depth of cut and relock it.
17. Engage the spindle and take the finish cut.
18. Stop the machine and return the work to the starting place.
19. Shut the machine off.
20. Remove the work from the vise. Handle it very carefully to keep from cutting yourself before you can deburr the work.
21. Next, mount the work in the vise so the other end is ready to be machined. Mill this end in the same manner as the first, but be sure to measure the length before you take the finishing cut. Before removing the work from the vise, check it for accuracy and remove the burrs from the newly finished end.

Angular milling is the milling of a flat surface that is at an angle to the axis of the cutter. Normally, you will use an angular milling cutter, as shown in figure 7-60. However, you can perform angular milling with a plain, side, or face milling cutter by positioning the work at the required angle.

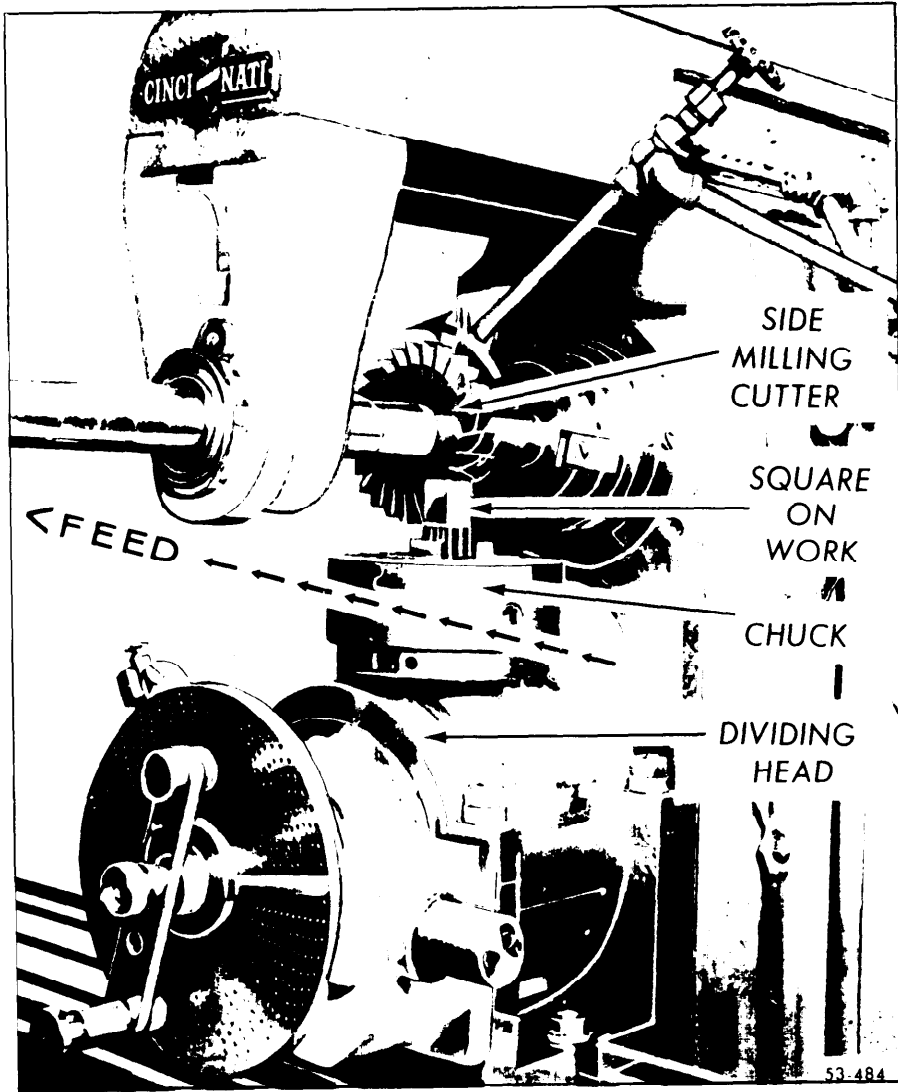
Many maintenance or repair tasks require you to machine flat surfaces on cylindrical work. They include milling squares and hexagons, and milling two flats in the same plane.

A square or hexagon is milled on an object to provide a positive drive, no slip area that can be grasped by various tools, such as wrenches and cranks. You will machine squares and hexagons frequently on the ends of bolts, taps, reamers, or other items that are turned by a wrench and on drive shafts and other items that require a positive drive. The following information will help you to understand the machining of squares and hexagons.

### Cutter Setup

The two types of cutters you will use most often to machine squares or hexagons are side and end milling cutters. You can use side milling cutters to machine work that is held in a chuck and for heavy cutting. You can use end mills for work that is held in a chuck or between centers and for light cutting. If you use a side milling cutter, be sure the cutter diameter is large enough so you can machine the full length of the square or hexagon without interference from the arbor. If you use an end mill, be sure it is slightly larger in diameter than the length of the square or hexagon. The cutter thrust for both types should be up when the work is mounted vertically and down when it is mounted horizontally in order to use conventional (or up) milling.

The reason for what appears to be a contradiction in the direction of thrust is the difference in the direction of the feed. You can see this by comparing figures 7-61 and 7-62. The cutter shown in figure 7-61 rotates in a counterclockwise direction and the work is fed toward the left. The cutter shown in figure 7-62 rotates in a clockwise direction and the work is fed upward.



28.407

Figure 7-61.—Milling a square on work held vertically.

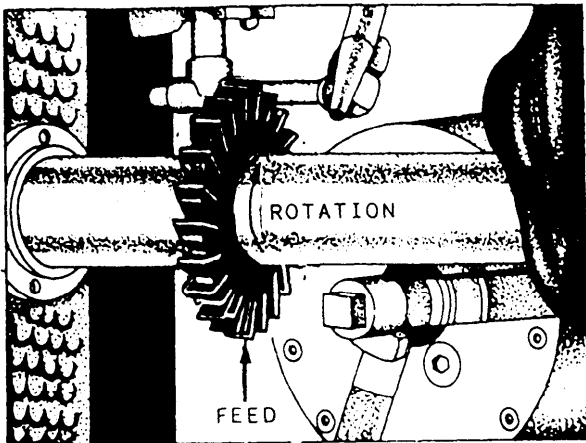
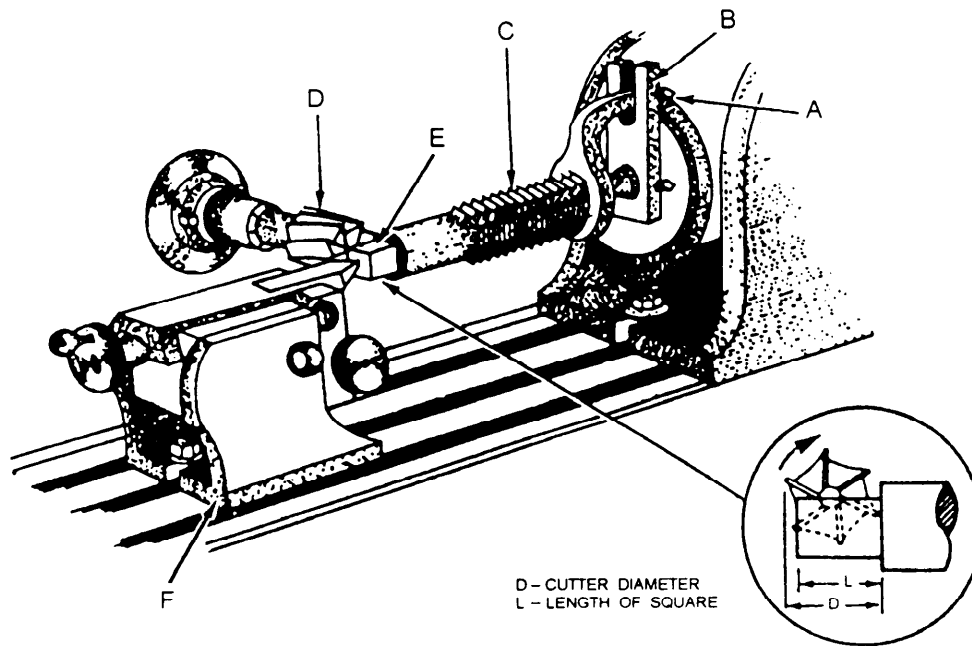


Figure 7-62.—Milling a square on work held horizontally.

### Work Setup

We have already discussed the methods that you will usually use to mount the work. Regardless of the workholding method, you must align the index spindle in either the vertical or the horizontal plane. If you machine work between centers, you must also align the footstock center. If you use a screw-on chuck, consider the cutter rotary thrust applied to the work. Always cut on the side of the work that will tend to tighten the chuck on the index head spindle. When you mount work between centers, a dog rotates the work. The drive plate,



- A. Lock screw for dog
- B. Drive plate
- C. Tap

- D. End mill
- E. Tap square
- F. Footstock

Figure 7-63.—Milling a square using an end mill.

shown in figure 7-63, contains two lock screws. One lock screw clamps the drive plate to the index center and ensures that the drive plate moves with the index spindle. The other lock screw clamps the tail of the dog against the side of the drive plate slot, as shown in figure 7-63, A. This eliminates any movement of the work during the machining operation.

### Calculations

The following information will help you determine the amount of material you must remove to produce a square or a hexagon. You must calculate the dimensions of the largest square or hexagon that you can machine from a piece of stock.

The size of a square (H in fig. 7-64) is measured across the flats. The largest square that you can cut from a given size of round stock equals the diameter of the stock in inches (which is also the diagonal of the square) times 0.707. This may be expressed as:

Opposite side = Side of a square

Hypotenuse = Diagonal of square

$45^\circ = 90^\circ$  bisected

$$H = G \times 0.707 \text{ or } \frac{\text{Opposite side}}{\text{Hypotenuse}} = \text{sine } 45^\circ$$

The diagonal of a square equals the distance across the flats times 1.414. This is expressed as

$$G = H \times 1.414 \text{ or } \frac{\text{Hypotenuse}}{\text{Opposite side}} = \text{cosec } 45^\circ$$

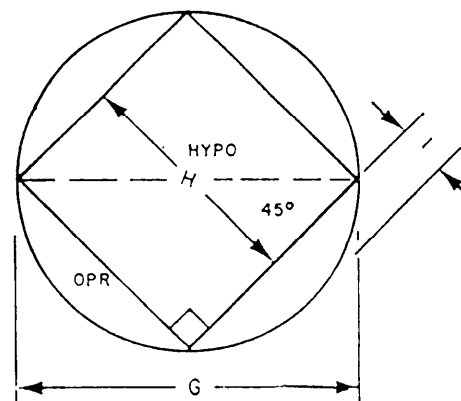


Figure 7-64.—Diagram of a square.

The amount of material that you must remove to machine each side of the square is equal to one-half the difference between the diameter of the stock and the distance across the flats.

$$I = \frac{G - H}{2}$$

You use the same formula

$$(I = \frac{G - H}{2})$$

to determine the amount of material to remove when you machine a hexagon.

The size of the largest hexagon that you can machine from a given size of round stock (H in fig. 7-65) is equal to the diagonal (the diameter of the stock) of the hexagon times 0.866 or

Opposite side = Largest hexagon that can be machined

Hypotenuse = Diagonal or diameter of round stock

$$H = G \times 0.866 \text{ or } \frac{\text{Opposite side}}{\text{Hypotenuse}} = \text{sine } 60^\circ$$

The diagonal of a hexagon equals the distance across the flats times 1.155, or

$$G = H \times 1.155 \text{ or } \frac{\text{Hypotenuse}}{\text{Opposite side}} = \text{cosec } 60^\circ$$

The length of a flat is equal to one-half the length of the diagonal,

$$r = \frac{G}{2}$$

We will explain two methods used to machine a square or hexagon: work mounted in a chuck and work mounted between centers.

You can machine a square or hexagon on work mounted in a chuck by using either a side milling cutter or an end mill. We will discuss the side milling cutter first. Before placing the index head on the milling machine table, be sure the table and the bottom of the index head have been cleaned of all chips and other foreign matter. Spread a thin film of clean machine oil over the area of the table to which the index head will be attached to prevent corrosion.

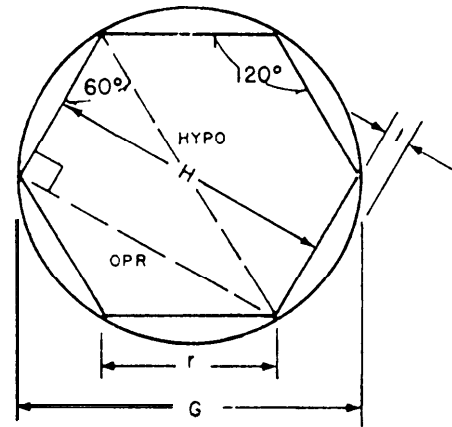


Figure 7-65.—Diagram of a hexagon.

**NOTE:** Because most index heads are quite heavy and awkward, you should get someone to help you place the head on the milling machine table.

After you have mounted the index head on the table, position the head spindle in the vertical position, as shown in figure 7-61. Use the degree graduations on the swivel block. This is accurate enough for most work requiring the use of the index head. The vertical position will allow you to feed the work horizontally.

Then, tighten the work in the chuck to keep it from turning due to the cutter's thrust. Install the arbor, cutter, and arbor support. The cutter should be as close as practical to the column. Remember, this is done so the setup will be more rigid. Set the machine for the correct roughing speed and feed.

1. With the cutter turning, pick up the cut on the end of the work.
2. Move the work sideways to clear the cutter.
3. Raise the knee a distance equal to the length of the flat surfaces to be cut.
4. Move the table toward the revolving cutter and pick up the side of the work. Use a piece of paper in the same manner as discussed earlier in this chapter and shown in figure 7-59.
5. Set the cross-feed graduated dial at ZERO.
6. Move the work clear of the cutter. Remember, the cutter should rotate so the cutting action takes place as in "up milling."
7. Feed the table in the required amount for a roughing cut.

8. Engage the power feed and the coolant flow.
9. When the cut is finished, stop the spindle and return the work to the starting point.
10. Loosen the index head spindle lock.
11. Rotate the work one-half revolution with the index crank.
12. Tighten the index head spindle lock.
13. Take another cut on the work.
14. When this cut is finished, stop the cutter and return the work to the starting point.
15. Measure the distance across the flats to determine whether the cutter is removing the same amount of metal from both sides of the work. If not, check your calculations and the setup for a possible mistake.
16. If the work measures as it should, loosen the index head spindle lock and rotate the work one-quarter revolution, tighten the lock, and take another cut.
17. Return the work to the starting point again.
18. Loosen the spindle lock.
19. Rotate the work one-half revolution.
20. Take the fourth cut.
21. Return the work again to the starting point and set the machine for finishing speed and feed.
22. Now, finish machine opposite sides (1 and 3), using the same procedures already mentioned.
23. Check the distance across these sides. If it is correct, finish machine the two remaining sides.
24. Deburr the work and check it for accuracy.

**NOTE:** You can also machine a square or hexagon with the index head spindle in the horizontal position, as shown in figures 7-62 and 7-63. If you use the horizontal setup, you must feed the work vertically.

### **Square or Hexagon Work Mounted Between Centers**

Machining a square or hexagon on work mounted between centers is done in much the same manner as when the work is held in a chuck.

1. Mount the index head the same way, only with the spindle in a horizontal position. The feed will be in a vertical direction.
2. Insert a center into the spindle and align it with the footstock center.
3. Select and mount the desired end mill, preferably one whose diameter is slightly greater than the length of the flat you are to cut, as shown in figure 7-63.
4. Mount the work between centers. Make sure that the drive dog is holding the work securely.
5. Set the machine for roughing speed and feed.
6. Pick up the side of the work and set the graduated cross-feed dial at ZERO.
7. Lower the work until the cutter clears the footstock.
8. Move the work until the end of the work is clear of the cutter.
9. Align the cutter with the end of the work. Use a square head and rule, as shown in figure 7-66.

**NOTE:** Turn the machine off before you align the cutter by this method.

10. Move the table a distance equal to the length of the flat desired.
11. Move the saddle the distance required for the roughing depth of cut.
12. While feeding the work vertically, machine side 1. Lower the work to below the cutter when you have completed the cut.
13. Loosen the index head spindle lock and index the work one-half revolution to machine the flat opposite side 1.
14. Tighten the lock.
15. Engage the power feed. After completing the cut, again lower the work to below the cutter and stop the cutter.
16. Measure the distance across the two flats to check the accuracy of the cuts. If it is correct, index the work one-quarter revolution to machine another side. When you complete that side, lower the work, index one-half revolution, and machine the last

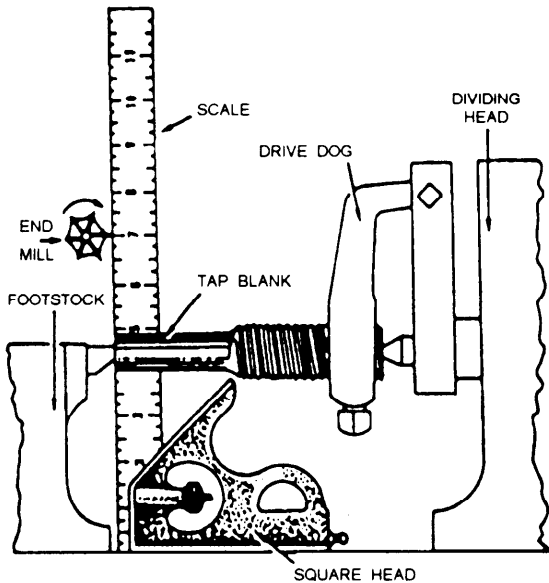


Figure 7-66.—Aligning the work and the cutter.

side. Remember to lower the work to below the cutter again.

17. Set the machine for finishing speed, feeds, and depth of cut, and finish machine all the sides.
18. Deburr the work and check it for accuracy.

### Machining Two Flats in One Plane

You will often machine flats on shafts to serve as seats for setscrews. One flat is simple to machine. You can machine in any manner with a side or end mill, as long as you can mount the work properly. However, machining two flats in one plane, such as the flats on the ends of a mandrel, presents a problem because the flats must align with each other. A simple method is to mount the work in a vise or on V-blocks in such a manner that you can machine both ends without moving the work once it has been secured.

We will describe the method that is used when the size or shape of the work requires repositioning it to machine both flats.

1. Apply layout dye to both ends of the work.
2. Place the work on a pair of V-blocks, as shown in figure 7-67.
3. Set the scribe point of the surface gauge to the center height of the work. Scribe horizontal lines on both ends of the work, as illustrated in figure 7-67.

4. Mount the index head on the table with its spindle in the horizontal position.
5. Again, set the surface gauge scribe point, but to the center line of the index head spindle.
6. Insert the work in the index head chuck with the end of the work extended far enough to permit all required machining operations.
7. To align the surface gauge scribe point with the scribed horizontal line, rotate the index head spindle.
8. Lock the index head spindle in position.

You can mill these flats with either an end mill, a side mill, or a side milling cutter.

**NOTE:** Rotate the cutter in a direction that will cause the thrust to tighten the index head chuck on the spindle when you use a screw-on type of chuck.

9. Raise the knee with the surface gauge still set at center height until the cutter center line is aligned with the scribe point. This puts the center lines of the cutter and the work in alignment with each other.
10. Position the work so that a portion of the flat to be machined is located next to the cutter. Because of the shallow depth of cut, compute the speed and feed as if the cuts were finishing cuts.

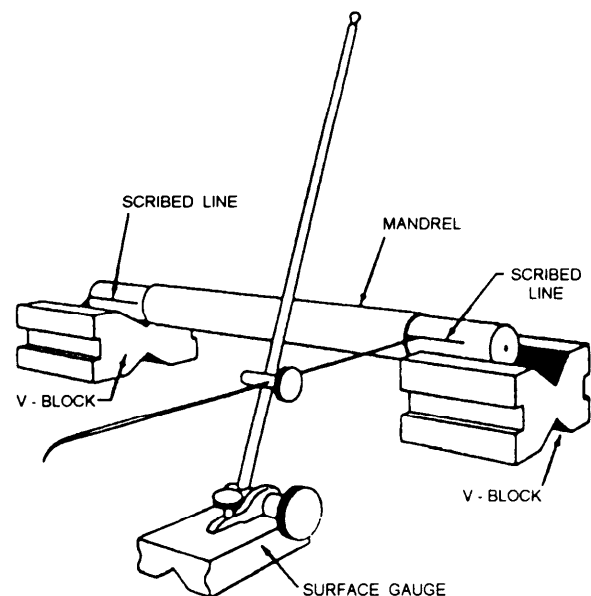


Figure 7-67.—Layout of the work.

11. After starting the machine, feed the work by hand so the cutter contacts the side of the work on which the line is scribed.
12. Move the work clear of the cutter and stop the spindle.
13. Check to see if the greater portion of the cutter mark is above or below the layout line. Depending on its location, rotate the index head spindle as required to center the mark on the layout line.
14. Once the mark is centered, take light "cut and try" depth of cuts until you reach the desired width of the flat.
15. Machine the flat to the required length.
16. When one end is completed, remove the work from the chuck. Turn the work end for end and reinsert it in the chuck.
17. Machine the second flat in the same manner as you did the first.
18. Deburr the work and check it for accuracy.
19. Check the flats to see if they are in the same plane by placing a matched pair of parallels on a surface plate and one flat on each of the parallels. If the flats are in the same plane, you will not be able to wobble the work.

## SLOTTING, PARTING, AND MILLING KEYSEATS

Slotting, parting, and milling keyseats are all operations that require you to cut grooves in the work. These grooves are of various shapes, lengths, and depths, depending on the requirements of the job. They range from flutes in a reamer to a keyseat in a shaft, to the parting off of a piece of metal to a predetermined length.

### Slotting

You can use slotting to cut internal contours, such as internal gears and splines and 6- or 12-point sockets. Most slotting is done with a milling machine attachment called a slotting attachment, as shown in figure 7-68. The slotting attachment is fastened to the milling machine column and driven by the spindle. This attachment changes the rotary motion of the spindle to a reciprocating motion much like that of a shaper. You can vary the length of the stroke within a specified range. A pointer on the slotting attachment

slide shows the length of the stroke. You can pivot the head of the slotting attachment and position it at any desired angle. Graduations on the base of the slotting attachment show the angle at which the head is positioned. The number of strokes per minute is equal to the spindle rpm and is determined by the formula:

$$\text{Strokes per minute} = \frac{\text{CFS} \times 4}{\text{length of stroke}}$$

To make the cutting tools used with slotting attachments, grind them to any desired shape from high-speed steel tool blanks. Clamp the tool to the front of the slide or ram. You can use any suitable means to hold the work, but the most common method is to hold the work in an index head chuck. If the slotted portion does not extend through the work, you will have to machine an internal recess in the work to provide clearance for the tool runout. When it is possible, position the slotting attachment and the work in the vertical position to provide the best possible view of the cutting action of the tool.

### Parting

Use a metal slitting saw for sawing or parting operations and to mill deep slots in metals and in a variety of other materials. Efficient sawing depends to a large extent on the slitting saw you select. The work required of slitting saws varies greatly. It would not be efficient to use the same saw to cut very deep

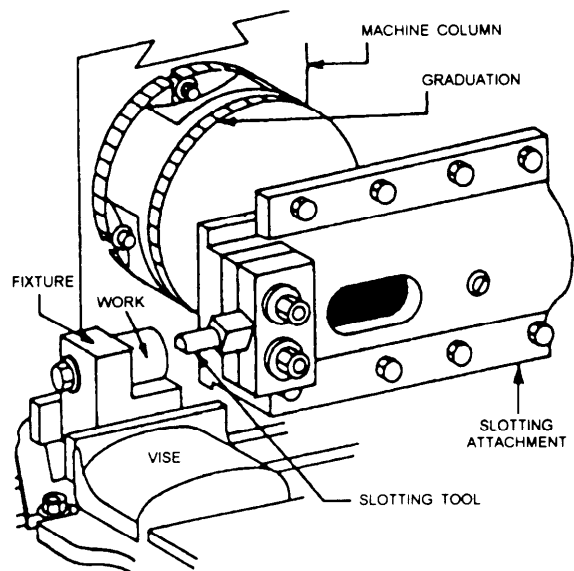


Figure 7-68.—Slotting attachment.



narrow slots, part thick stock, saw thin stock, or saw hard alloy steel. Soft metals, such as copper and babbitt, or nonmetallic materials, such as bakelite, fiber, or plastic, require their own style of slitting saw.

Parting with a slitting saw leaves pieces that are reasonably square and that require you to remove a minimum of stock to finish the surface. You can cut off a number of pieces of varying lengths and with less waste of material than you could saw by hand.

A coarse-tooth slitting saw is best to saw brass and to cut deep slots. A fine-tooth slitting saw is best to saw thin metal, and a staggered-tooth slitting saw is best to make heavy deep cuts in steel. You should use slower feeds and speeds to saw steels to prevent cutter breakage. Use conventional milling to saw thick material. To saw thin material, however, clamp the stock directly to the table and use down milling. Then, the slitting saw will tend to force the stock down on the table. Position the work so the slitting saw extends through the stock and into a table T-slot.

### External Keyseat

It is less complicated to machine an external keyseat on a milling machine than on a shaper. In milling, it is no problem to start an external keyseat. Simply bring the work into contact with a rotating cutter and start cutting. You should be able to picture in your mind how you'll mill a straight external keyseat with a plain milling cutter or an end mill. If the specified length of the keyseat exceeds the length you can obtain by milling to the desired depth, you can move the work in the direction of the slot to get the desired length. It should be easier to picture in

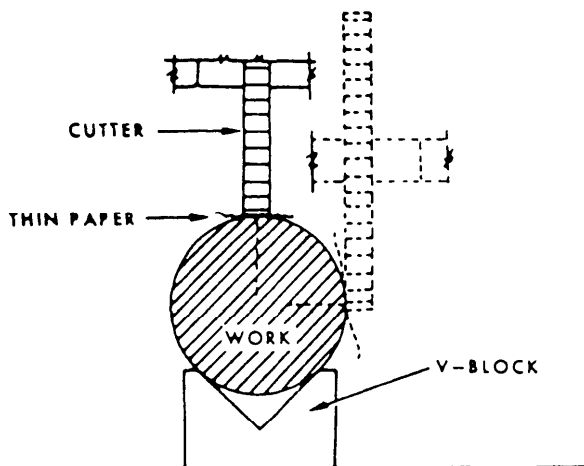


Figure 7-69.—Aligning the cutter using a paper strip.

your mind how you'll mill a Woodruff keyseat. The secret is to select a cutter that has the same diameter and thickness as the key.

### STRAIGHT EXTERNAL KEYSEATS.—

Normally, you'll use a plain milling cutter to mill a straight external keyseat. You also can use a Woodruff cutter or a two-lipped end mill.

Before you can begin milling, align the axis of the work with the midpoint of the width of the cutter. Figure 7-69 shows one method of alignment.

Suppose you're going to cut a keyseat with a plain milling cutter. First, move the work until the side of the cutter is tangent to the circumference of the work. With the cutter turning very slowly and before contact is made, insert a piece of paper between the work and the side of the cutter. Continue moving the work toward the cutter until the paper begins to tear. When it does, lock the graduated dial at ZERO on the saddle feed screw. Then, lower the milling machine knee. Use the saddle feed dial as a guide, and move the work a distance equal to the radius of the work plus one-half the width of the cutter. This will center the cutter over the center line of the keyseat.

Use a similar method to align work with an end mill. Move the work toward the cutter while you hold a piece of paper between the rotating cutter and the work, as shown in figure 7-70. After the paper tears, lower the work to just below the bottom of the end

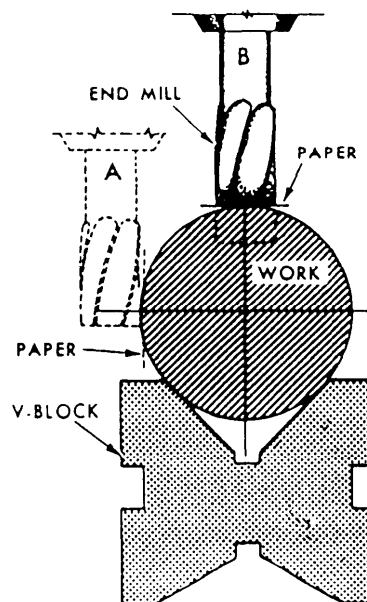


Figure 7-70.—Aligning an end mill with the work.

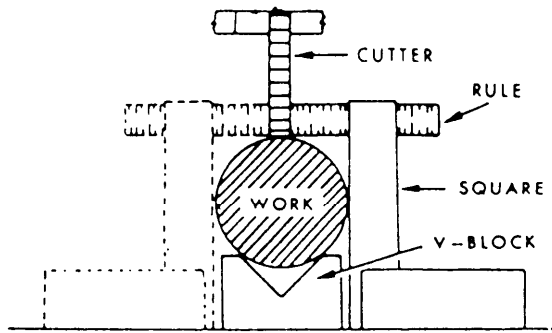


Figure 7-71.—Visual alignment of a cutter.

mill. Then, move the work a distance equal to the radius of the work plus the radius of the end mill. This will center the mill over the center line of the keyseat. Move the work up, using hand feed, until a piece of paper held between the work and the bottom of the end mill begins to tear, as shown in figure 7-70, B. Then, move the table and work away from the bottom of the end mill. Set and lock the graduated dial at ZERO on the vertical feed, and then feed up for the roughing cut. You can determine the cutter rpm and the longitudinal feed in the same manner as you do for conventional milling cutters. The higher speeds and feeds generate more heat, so flood the work and the cutter with coolant.

When extreme accuracy is not required, you can align the work with the cutter visually, as shown in figure 7-7 1. Position the work by eye as near as possible to the midpoint of the cutter. Make the final alignment by moving the work in or out a slight amount, as needed. The cutter should be at the exact center of the work diameter measurement of the steel rule. You can use this method with both plain milling cutters and end mills.

Before you begin to machine the keyseat, you should measure the width of the cut. You cannot be certain that the width will be the same as the thickness of the cutter. The cutter may not run exactly true on the arbor or the arbor may not run exactly true on the spindle. The recommended practice is to nick the end of the work with the cutter and then to measure the width of the cut.

Specifications for the depth of cut are usually furnished. When they are not available, you can determine the total depth of cut for a square keyseat by using the following formula based on dimensions shown in figure 7-72.

$$\text{Total depth of cut } (T) = d + f$$

where

$$d = \frac{W}{2} = \text{depth of the keyseat}$$

$$f = R - \sqrt{R^2 - \left(\frac{W}{2}\right)^2} = \text{height of arc}$$

$W$  = width of the key

$R$  = radius of the shaft

The height of arc ( $f$ ) for various sizes of shafts and keys is shown in table 7-1. Keyseat dimensions for rounded end and rectangular keys are contained in the *Machinery's Handbook*. Check the keyseats for accuracy with rules, outside and depth micrometers, vernier calipers, and go-no-go gauges. Use table 7-1 for both square and Woodruff keyseats, which will be explained next.

**WOODRUFF KEYSEAT.**—A Woodruff key is a small half-disk of metal. The rounded portion of the key fits in the slot in the shaft. The upper portion fits into a slot in a mating part, such as a pulley or gear. You align the work with the cutter and measure the width of the cut in exactly the same manner as you do to mill straight external keyseats.

A Woodruff keyseat cutter (fig. 7-73) has deep flutes cut across the cylindrical surface of the teeth. The cutter is slightly thicker at the crest of the teeth than it is at the center. This feature provides clearance between the sides of the slot and the cutter. Cutters

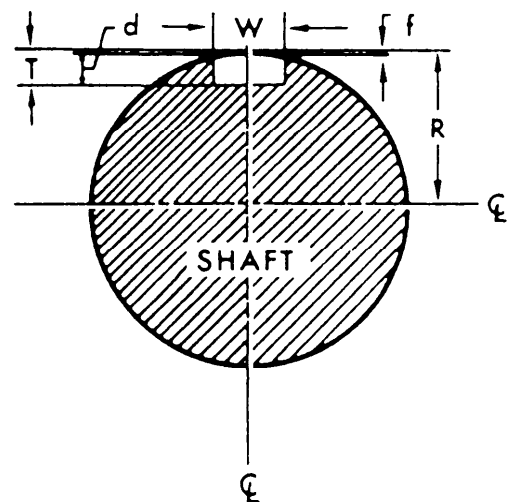


Figure 7-72.—Keyseat dimensions for a straight square key.

Table 7-1.—Values for Factor (f) for Various Sizes of Shafts

WIDTH OF KEY IN INCHES								
DIAMETER OF SHAFT (INCHES)	1/16	3/32	1/8	5/32	3/16	7/32	1/4	5/16
SHAFT SIZE	FACTOR (f)							
1/2	.002	.004	.008	.013	.018	.025	.033	---
5/8	.001	.003	.006	.010	.014	.019	.025	.042
3/4	.001	.003	.005	.008	.012	.016	.022	.034
7/8	.001	.002	.004	.007	.010	.014	.018	.028
1	.001	.002	.004	.006	.009	.012	.015	.024
1 1/8	----	.002	.003	.005	.008	.011	.014	.022
1 1/4	----	.002	.003	.005	.007	.010	.013	.019
1 1/2	----	.001	.002	.004	.006	.008	.011	.016
1 3/4	----	.001	.002	.003	.005	.007	.009	.014

with a 2-inch or larger diameter have a hole in the center to mount the arbor. On smaller cutters, the cutter and the shank are one piece. Note that the shank is “necked” in back of the cutting head to give additional clearance. Also, note that large cutters usually have staggered teeth to improve their cutting action.

We said earlier that to mill a Woodruff keyseat in a shaft, you should use a cutter that has the same diameter and thickness as the key. It is relatively simple to cut a Woodruff keyseat. You simply move the work up into the cutter until you get the desired keyseat depth. You may hold the work in a vise, chuck, between centers, or clamped to the milling

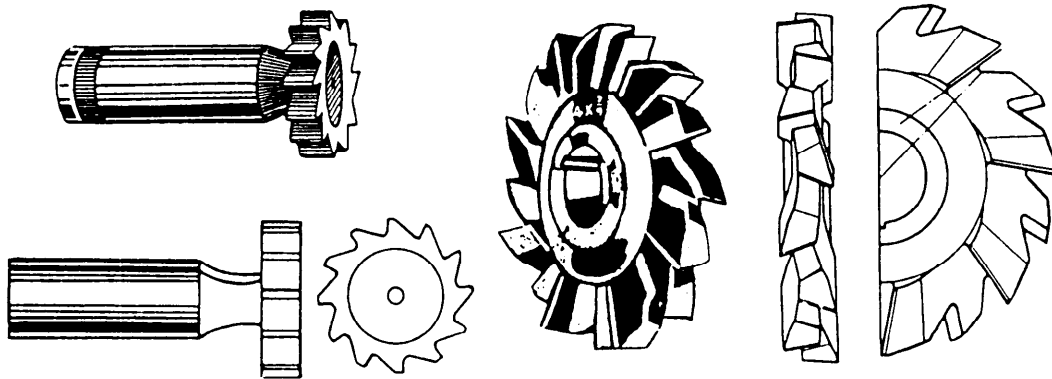


Figure 7-73.—Woodruff keyseat cutter.

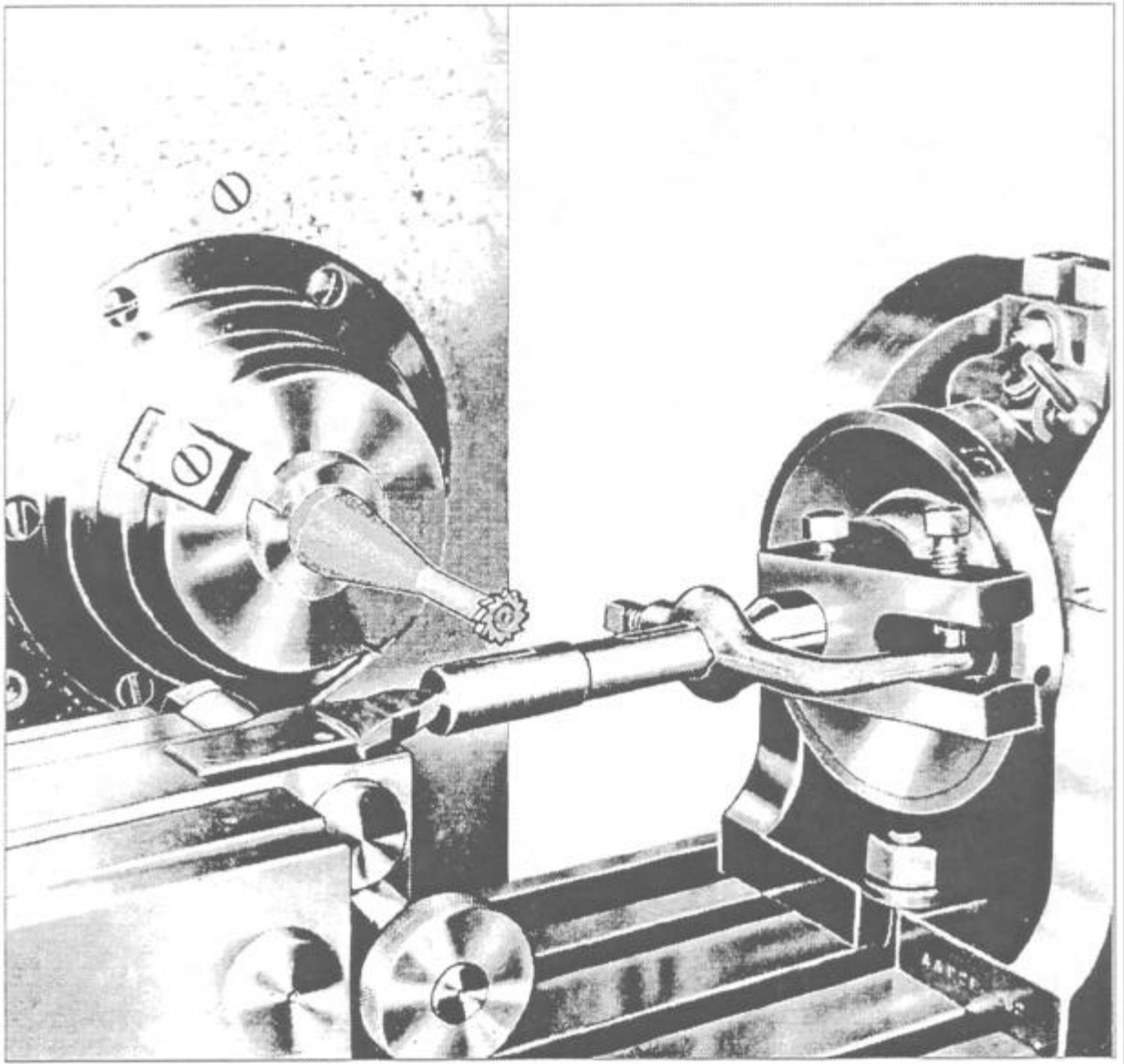


Figure 7-74.—Milling a Woodruff keyseat.

machine table. You will hold the cutter on an arbor, or in a spring collet or drill chuck that has been mounted in the spindle of the milling machine, as in figure 7-74.

In milling the keyseat, locate the cutter centrally over the position in which the keyseat will be cut and parallel with the axis of the work. Raise the work by using the hand vertical feed until the revolving cutter tears a piece of paper held between the teeth of the cutter and the work. At this point, set the graduated dial on the vertical feed at ZERO and set the clamp on the table. With the graduated dial as a guide, raise the work by hand until the full depth of the keyseat is cut. If specifications for the total depth of cut are not

available, use the following formula to determine the correct value:

$$\text{Total depth } (T) = d + f$$

where

$$d \text{ (depth of the keyseat)} = H - \frac{W}{2}$$

$$H = \text{total height of the key}$$

$$W = \text{width of the key}$$

The most accurate way to check the depth of a Woodruff keyseat is to insert a Woodruff key of the correct size in the keyseat. Measure over the key and the work with an outside micrometer to obtain the

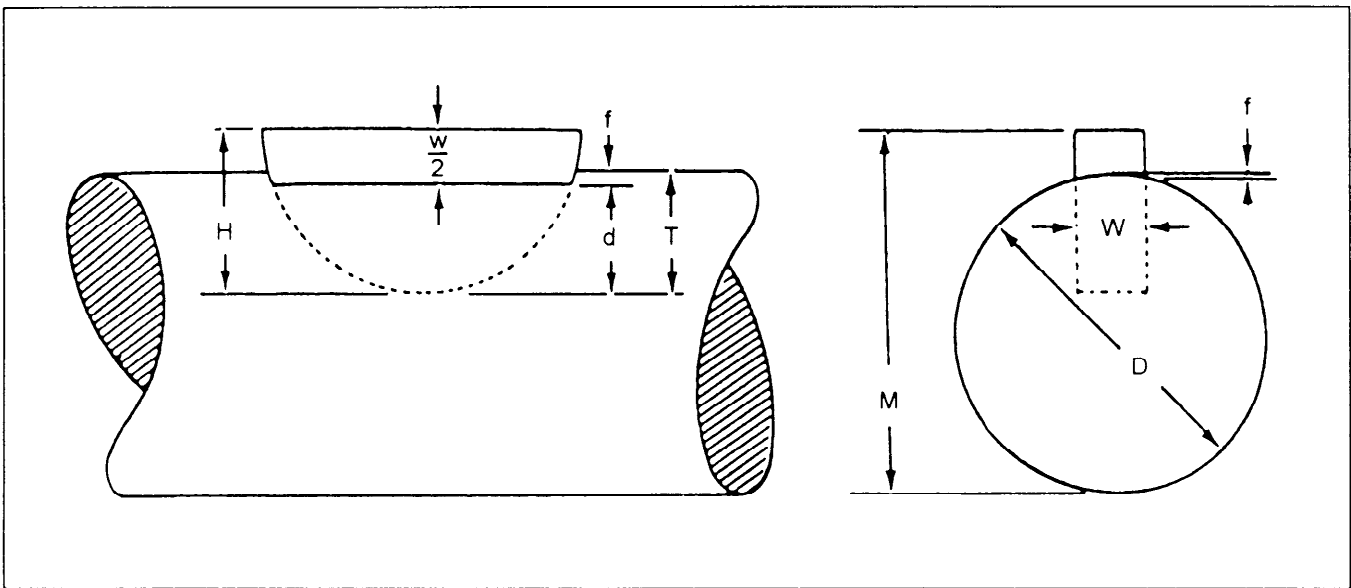


Figure 7-75—Dimensions for a Woodruff keyseat.

distance,  $M$  in figure 7-75. You can also determine distance  $M$  by using the formula:

$$M = D + \frac{(W)}{(2)} - f$$

where

$M$  = micrometer reading

$D$  = diameter of the shaft

$f$  = height of the arc between the top of the slot and the top of the shaft

**NOTE:** Tables in some references may differ slightly from the above calculation for the value  $M$ , due to greater allowance for clearance at the top of the key.

## FLY CUTTING

You will use a fly cutter when a formed cutter is required but not available. Fly cutters are high-speed steel tool blanks that have been ground to the required shape. Any shape can be ground on the tool if the cutting edges arc given enough clearance. Fly cutters are mounted in fly cutter arbors, such as the one shown in figure 7-45. Use a slow feed and a shallow depth of cut to prevent breaking the tool. It is a good idea to rough out as much excess material as possible with ordinary cutters and to use the fly cutter to finish shaping the surface.

## DRILLING, REAMING, AND BORING

Drilling, reaming, and boring are operations that you can do very efficiently on a milling machine. The graduated feed screws make it possible to accurately locate the work in relation to the cutting tool. In each operation the cutting tool is held and rotated by the spindle, and the work is fed into the cutting tool.

### Drilling and Reaming

Use the same drills and reamers that you use to drill and ream in the lathe and the drill press. Hold drills and reamers in the spindle by the same methods that you use to hold straight and taper-shanked end mills. You can hold the work in a vise, clamped to the table, held in fixtures or between centers, and in index head chucks, as you do in milling. Determine the speeds used to drill and ream in the same manner as you did those used to drill and ream in the lathe or the drill press. Feed the work into the drill or reamer by either hand or power feed. If you mount the cutting tool in a horizontal position, use the transverse or saddle feed. If you mount a drill or reamer in a vertical position, as in a vertical-type machine, use the vertical feed.

### Boring

Of the three operations, boring is the only one that warrants special treatment. On a milling machine you

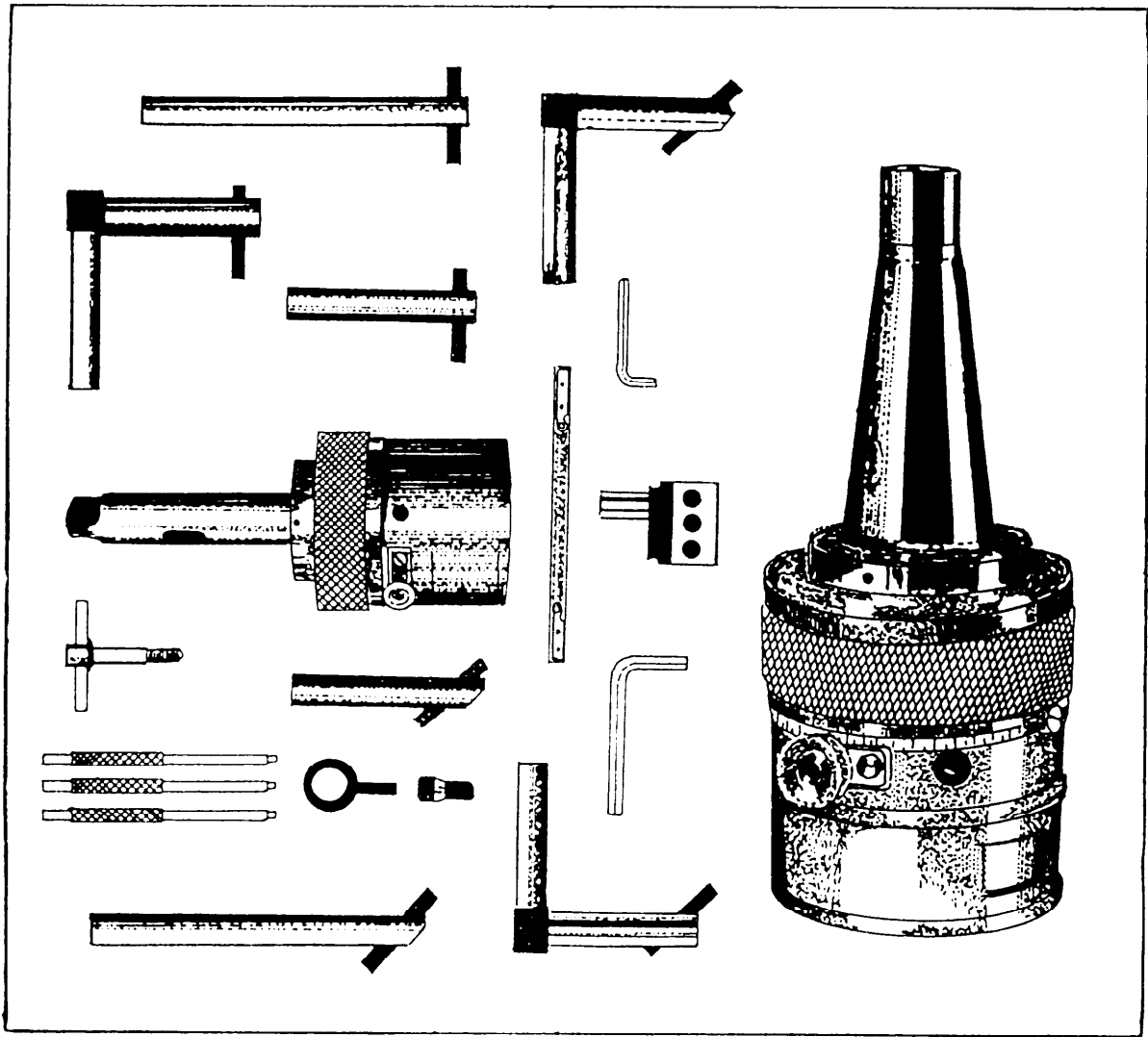


Figure 7-76.—Offset boring head and boring tools.

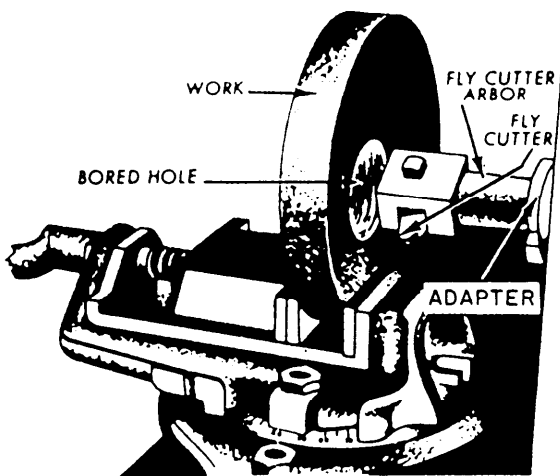


Figure 7-77.—Boring with a fly cutter.

usually bore holes with an offset boring head. Figure 7-76 shows several views of an offset boring head and several boring tools. Note that the chuck jaws, which grip the boring bar, can be adjusted at a right angle to the spindle axis. This feature lets you accurately position the boring cutter to bore holes of varying diameters. This adjustment is more convenient than adjusting the cutter in the boring bar holder or by changing boring bars.

Although the boring bars are the same on a milling machine as on a lathe or drill press, the manner in which they are held is different. Note in figure 7-77 that a boring bar holder is not used. The boring bar is inserted into an adapter and the adapter is fastened in the hole in the adjustable slide. Power to drive the boring bar is transmitted directly through the shank. The elimination of the boring bar holder

Deleted—No permission  
granted for electronic copy.

**Figure 7-78.—Universal milling (head) attachment.**

results in a more rigid boring operation, but the size of the hole that can be bored is more limited than those on a lathe or a drill press.

Fly cutters, which we discussed previously, can also be used for boring, as shown in figure 7-77. A fly cutter is especially useful to bore relatively shallow holes. The cutting tool must be adjusted for each depth of cut.

The speeds and feeds you should use to bore on a milling machine are comparable to those you would use to bore on a lathe or drill press. They also depend on the same factors: hardness of the metal, kind of metal in the cutting tool, and depth of cut. The boring bar is a single-point cutting tool; therefore, the

diameter of the arc through which the tool moves is also a factor. For all of these reasons you must avoid too-great of speeds to prevent vibration.

### **MILLING MACHINE ATTACHMENTS**

Many attachments have been developed that increase the number of jobs a milling machine can do, or that make such jobs easier to do.

### **UNIVERSAL MILLING ATTACHMENT**

The universal milling (head) attachment, shown in figure 7-78, is clamped to the column of the milling machine. The cutter can be secured in the spindle of

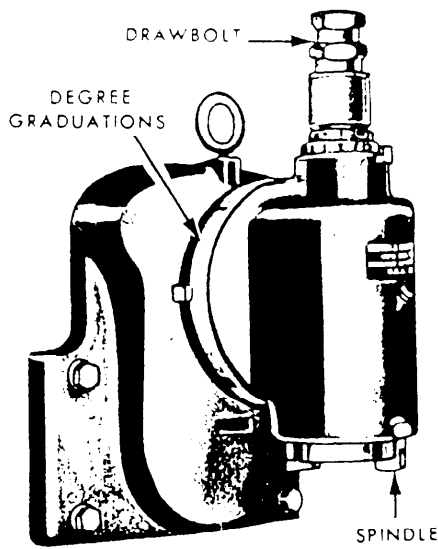


Figure 7-79.—Vertical milling attachment.

the attachment and then set by the two rotary swivels so the cutter will cut at any angle to the horizontal or the vertical plane. The spindle of the attachment is driven by gearing connected to the milling machine spindle.

### VERTICAL MILLING ATTACHMENT

You can use a vertical milling attachment (fig. 7-79) to convert the horizontal spindle machine to a vertical spindle machine and swivel the cutter to any position in the vertical plane. You can use a universal milling attachment to swivel the cutter to any position in both the vertical and horizontal planes. These attachments will help simplify otherwise complex jobs.

### HIGH-SPEED UNIVERSAL ATTACHMENT

You can use a high-speed universal attachment to perform milling operations at higher speeds than those for which the machine was designed. This attachment is clamped to the machine and driven by the milling machine spindle, as you can see in figure 7-80. You can swivel the attachment spindle head and cutter 360° in both planes. The attachment spindle is driven at a higher speed than the machine spindle. You must consider the ratio between the rpm of the two spindles when you calculate cutter speed. Drive small cutters, end mills, and drills at high rates of speed to maintain an efficient cutting action.

### RACK MILLING ATTACHMENT

The rack milling attachment, shown in figure 7-81, is used primarily to cut teeth on racks, although it can be used for other operations. The cutter is mounted on a spindle that extends through the attachment parallel to the table T-slots. An indexing arrangement is used to space the rack teeth quickly and accurately.

### FEEDS, SPEEDS, AND COOLANTS

Milling machines usually have a spindle speed range from 25 to 2,000 rpm and a feed range from 1/4 inch to 30 inches per minute (ipm). The feed is independent of the spindle speed; therefore, you can feed a workpiece at any rate available in the feed range regardless of the spindle speed. In the following paragraphs, we'll discuss some of the factors concerning the selection of appropriate milling feeds and speeds.

### SPEEDS

Heat generated by friction between the cutter and the work may be regulated by the use of proper speed, feed, and cutting coolant. Regulation of this heat is

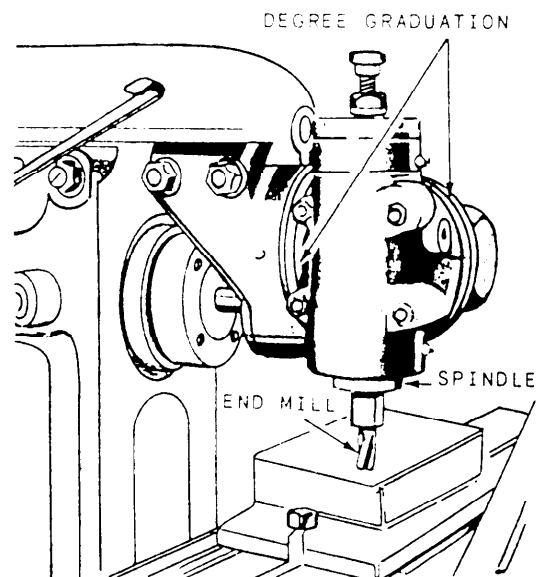


Figure 7-80.—High-speed universal milling attachment.



Deleted—No permission  
granted for electronic copy.

**Figure 7-81.—Rack milling attachment.**

very important because the cutter will be dulled or even made useless by overheating. It is almost impossible to provide any fixed rules that will govern cutting speeds because of varying conditions from job to job. Generally speaking, you should select a cutting speed that will give the best compromise between maximum production and longest life of the cutter. In any particular operation, consider the following factors to determine the proper cutting speed:

- Hardness of the material being cut: The harder and tougher the metal being cut, the slower should be the cutting speed.
- Depth of cut and desired finish: The amount of friction heat produced is directly proportional to the amount of material being removed. Therefore, you can often make finishing cuts at a speeds 40 to 80 percent higher than that used in roughing.
- Cutter material: You can operate high-speed steel cutters from 50 to 100 percent faster than carbon steel cutters because the high-speed cutters have better heat-resistant properties. Depending on the setup, you can operate carbide cutters at up to 4 times the speed of high-speed steel cutters.
- Type of cutter teeth: Cutters that have undercut teeth cut more freely than those that have a radial face. Therefore, you may run cutters with undercut teeth at higher speeds.
- Sharpness of the cutter: You can run a sharp cutter at a much higher speed than a dull cutter.
- Use of coolant: Sufficient coolant will usually cool the cutter so that it will not overheat even at relatively high speeds.

**Table 7-2.—Surface Cutting Speeds**

	HIGH-SPEED STEEL CUTTERS (FEET PER MINUTE)	
	ROUGH	FINISH
CAST IRON: Malleable	90	100
Hard castings	15	20
ANNEALED TOOL STEEL	40	50
LOW - CARBON STEEL	60	70
BRASS	110	150
ALUMINIUM	700	900

Use the approximate values in table 7-2 as a guide when you select the proper cutting speed for high-speed steel cutters. Refer to the manufacturer's recommendations if you are using carbide tooling. If you find you cannot suitably operate the machine, the

cutter, or the work at the suggested speed, make an immediate readjustment.

Use table 7-3 to determine the cutter rpm for cutters varying in diameter from 1/4 inch to 5 inches. For example: You are cutting with a 7/16-inch cutter. If a surface speed of 160 fpm is required, the cutter rpm will be 1,398.

If the cutter diameter you are using is not shown in table 7-3, determine the proper rpm of the cutter by using the formula:

$$(a) \text{ rpm} = \frac{\text{Cutting speed} \times 12}{3.1416 \times \text{Diameter}}$$

$$\text{or rpm} = \frac{\text{fpm}}{0.2618 \times D}$$

where

*rpm* = revolutions per minute of the cutter

*fpm* = required surface speed in feet per minute

*D* = diameter of the cutter in inches

$$0.2618 = \text{constant} = \frac{\pi}{12}$$

**Table 7-3.—Cutter Speeds in Revolutions Per Minute**

Diameter of cutter (in.)	Surface speed (ft. per min.)																
	25	30	35	40	50	55	60	70	75	80	90	100	120	140	160	180	200
	Cutter revolutions per minute																
1/4	382	458	535	611	764	851	917	1,070	1,147	1,222	1,376	1,528	1,834	2,139	2,445	2,750	3,056
5/16	306	367	428	489	611	672	733	856	917	978	1,100	1,222	1,466	1,711	1,955	2,200	2,444
3/8	255	306	357	408	509	560	611	713	764	815	916	1,018	1,222	1,425	1,629	1,832	2,036
7/16	218	262	306	349	437	481	524	611	656	699	786	874	1,049	1,224	1,398	1,573	1,748
1/2	191	229	268	306	382	420	459	535	573	611	688	764	917	1,070	1,222	1,375	1,528
5/8	153	184	214	245	306	337	367	428	459	489	552	612	736	857	979	1,102	1,224
3/4	127	153	178	203	254	279	306	357	381	408	458	508	610	711	813	914	1,016
7/8	109	131	153	175	219	241	262	306	329	349	392	438	526	613	701	788	876
1	95.5	115	134	153	191	210	229	267	287	306	344	382	458	535	611	688	764
1 1/4	76.3	91.8	107	123	153	168	183	214	230	245	274	306	367	428	490	551	612
1 1/2	63.7	76.3	89.2	102	127	140	153	178	191	204	230	254	305	356	406	457	508
1 3/4	54.5	65.5	76.4	87.3	109	120	131	153	164	175	196	218	262	305	349	392	436
2	47.8	57.3	66.9	76.4	95.5	105	115	134	143	153	172	191	229	267	306	344	382
2 1/2	38.2	45.8	53.5	61.2	76.3	84.2	91.7	107	114	122	138	153	184	213	245	275	306
3	31.8	38.2	44.6	51	63.7	69.9	76.4	89.1	95.3	102	114	127	152	178	208	228	254
3 1/2	27.3	32.7	38.2	44.6	54.5	60	65.5	76.4	81.8	87.4	98.1	109	131	153	174	196	213
4	23.9	28.7	33.4	38.2	47.8	52.6	57.3	66.9	71.7	76.4	86	95.6	115	134	153	172	191
5	19.1	22.9	26.7	30.6	38.2	42	45.9	53.5	57.3	61.1	68.8	76.4	91.7	107	122	138	153

Example: What is the spindle speed for a 1/2-inch cutter running at 45 fpm?

$$rpm = \frac{45}{0.2618 \times 0.5}$$

$$rpm = 343.7$$

To determine cutting speed when you know the spindle speed and cutter diameter, use the following formula:

$$fpm \times 12 = rpm \times 3.1416 \times D$$

$$fpm = \frac{3.1416 \times Diameter \times rpm}{12}$$

$$fpm = 0.2618 \times D \times rpm$$

Example: What is the cutting speed of a 2 1/4-inch end mill running at 204 rpm?

$$fpm = 0.2618 \times D \times rpm$$

$$rpm = 0.2618 \times 2.25 \times 204$$

$$fpm = 120.1$$

## FEEDS

The rate of feed is the rate of speed at which the workpiece travels past the cut. When selecting the feed, consider the following factors:

- Forces are exerted against the work, the cutter, and their holding devices during the cutting process. The force exerted varies directly with the amount of metal being removed and can be regulated by adjusting the feed and the depth of cut. The feed and depth of cut are therefore interrelated, and depend on the rigidity and power of the machine. Machines are limited by the power they can develop to turn the cutter and by the amount of vibration they can withstand during coarse feeds and deep cuts.
- The feed and depth of cut also depend on the type of cutter you are using. For example, do

not attempt deep cuts or coarse feeds with a small diameter end mill; it will spring or break the cutter. You can feed coarse cutters with strong cutting teeth at a relatively high rate of feed because the chips will be washed out easily by the coolant.

- Do not use coarse feeds and deep cuts on a frail piece of work or on work mounted in such a way that the holding device will spring or bend.
- The desired degree of finish affects the amount of feed. A fast feed removes metal rapidly and the finish will not be very smooth. However, a slow feed and a high cutter speed will produce a finer finish. For roughing, it is advisable to use a comparatively low speed and a coarse feed. You will make more mistakes if you overspeed the cutter than if you overfeed the work. Overspeeding is indicated by a squeaking, scraping sound. If chattering occurs in the milling machine during the cutting process, reduce the speed and increase the feed. Other common causes of chattering are excessive cutter clearance, poorly supported work, or a badly worn machine gear.

One procedure used to select an appropriate feed for a milling operation is to consider the chip load of each cutter tooth. The chip load is the thickness of the chip that a single tooth removes from the work as it passes over the surface. For example, when a cutter with 12 cutting teeth and a feed rate of 1 ipm turns at 60 rpm, the chip load of a single tooth of the cutter will be 0.0014 inch. An increase of cutter speed to 120 rpm reduces the chip load to 0.0007 inch; an increase of feed to 2 ipm increases chip load to 0.0028 inch. Use the following formula to calculate chip load:

$$Chip\ load = \frac{feed\ rate\ (ipm)}{cutter\ speed\ (rpm) \times number\ of\ teeth\ in\ the\ cutter}$$

Table 7-4.—Recommended Chip Loads

Material	Face Mills	Helical Mills	Slotting & Side Mills	End Mills	Form Relieved Cutters	Circular Saws
Plastic . . . . .	.013	.010	.008	.007	.004	.003
Magnesium and alloys	.022	.018	.013	.011	.007	.005
Aluminum and alloys	.022	.018	.013	.011	.007	.005
Free cutting brasses & bronzes . . . . .	.022	.018	.013	.011	.007	.005
Medium brasses & bronzes . . . . .	.014	.011	.008	.007	.004	.003
Hard brasses & bronzes . . . . .	.009	.007	.006	.005	.003	.002
Copper . . . . .	.013	.010	.007	.006	.004	.003
Cast iron, soft (150-180 BH)*. . . . .	.016	.013	.009	.008	.005	.004
Cast iron, med. (180-220 BH) . . . . .	.013	.010	.007	.007	.004	.003
Cast iron, hard (220-300 BH) . . . . .	.011	.008	.006	.006	.003	.003
Malleable iron . . . . .	.012	.010	.007	.006	.004	.003
Cast steel . . . . .	.012	.010	.007	.006	.004	.003
Low carbon steel, free mach. . . . .	.012	.010	.007	.006	.004	.003
Low carbon steel . . . . .	.010	.008	.006	.005	.003	.003
Medium carbon steel	.010	.008	.006	.005	.003	.003
Alloy steel, annealed (180-220 BH) . . . . .	.008	.007	.005	.004	.003	.002
Alloy steel, tough (220-300 BH) . . . . .	.006	.005	.004	.003	.002	.002
Alloy steel, hard (300-400 BH) . . . . .	.004	.003	.003	.002	.002	.001
Stainless steel, free mach. . . . .	.010	.008	.006	.005	.003	.002
Stainless steels . . . . .	.006	.005	.004	.003	.002	.002
Monel metals . . . . .	.008	.007	.005	.004	.003	.002

\* (BH: Brinell Hardness Number)

Table 7-4 shows recommended chip loads for milling various materials with various types of high-speed steel cutters.

**COOLANTS**

The purpose of a cutting coolant is to reduce frictional heat and thereby extend the life of the cutter's edge. Coolant also lubricates the cutter face and flushes away the chips, reducing the possibility of damage to the finish.

There are a number of synthetic coolants. Follow the manufacturer's recommendations when mixing them. If a synthetic coolant is not available, you can use soluble oil mixed at the rate of 40 parts water to 1 part oil.

When using a periphery milling cutter, apply the coolant to the point at which the tooth leaves the work. This will allow the tooth to cool before you begin the next cut. Allow the coolant to flow freely on the work and cutter.

## CHAPTER 8

# VERTICAL TURRET LATHE AND HORIZONTAL BORING MILL

### CHAPTER LEARNING OBJECTIVES

*Upon completing this chapter, you should be able to do the following:*

- Describe and explain the use of a vertical turret lathe.
- Describe and explain the use of a horizontal boring mill.

A vertical turret lathe works much like an engine lathe turned up on end. You can perform practically all of the typical lathe operations on a vertical turret lathe, including turning, facing, boring, machining tapers, and cutting internal and external threads.

A horizontal boring mill can be used for many kinds of shopwork, such as facing, boring, drilling, and milling. In horizontal boring mill work, the setup of the work, as well as the setting of the tools, is similar to that found in lathe and milling machine work.

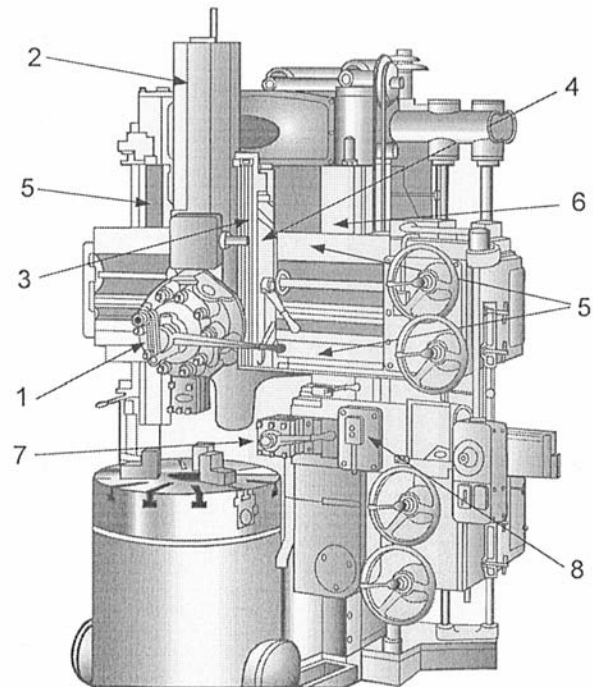
As with any shop equipment you must observe all posted safety precautions. Review your equipment operators manual for safety precautions and any chapters of *Navy Occupational Safety and Health (NAVOSH) Program Manual for Forces Afloat*, OPNAV Instruction 5100.19B, that pertain to the equipment.

### VERTICAL TURRET LATHE

The characteristic features of the vertical turret lathe are (1) a horizontal table or faceplate that holds the work and rotates about a vertical axis; (2) a side head that can be fed either horizontally or vertically; and (3) a turret slide, mounted on a crossrail that can feed nonrotating tools either vertically or horizontally.

Figures 8-1 and 8-2 show vertical turret lathes similar to those generally found in repair ships and shore repair facilities. The main advantage of the vertical turret lathe over the engine lathe is that heavy or awkward parts are easier to set up on the vertical turret lathe and, generally, the vertical turret lathe will handle much larger workpieces than the engine lathe. The size of the vertical turret lathe is designated by

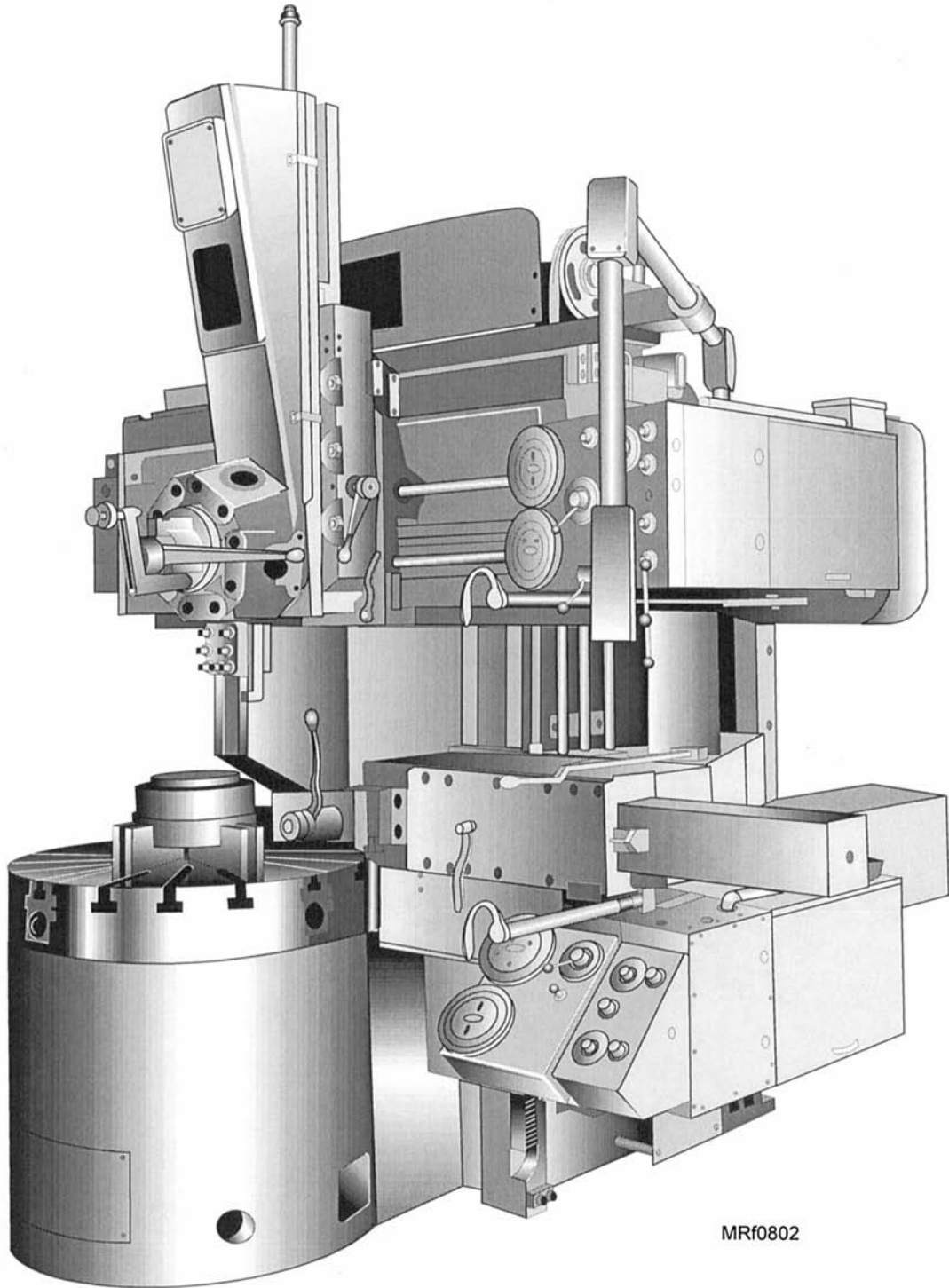
the diameter of the table. For instance, a 30-inch lathe has a table 30 inches in diameter. The capacity of a specific lathe is not necessarily limited to the size of the table. A 30-inch vertical lathe (fig. 8-1) can hold and machine a workpiece up to 34 inches in diameter by using both the main and side turrets. If you use



MR10801

- |                      |                     |
|----------------------|---------------------|
| (1) Main turret head | (5) Main rails      |
| (2) Turret slide     | (6) Upright bedways |
| (3) Swivel plate     | (7) Side turret     |
| (4) Saddle           | (8) Side head       |

Figure 8-1.—A 30-inch vertical turret lathe.



MRf0802

Figure 8-2.—A 36-inch vertical turret lathe.

only the main turret, you can machine a workpiece as large as 44 inches in diameter.

The main difference between the vertical turret lathe and the horizontal turret lathe is in the design and operating features of the main turret head. Refer to figure 8-1. Note that the turret slide (2) is mounted on a swivel plate (3) which is attached to the saddle (4). The swivel plate allows the turret slide to be swung up to 45° to the right or left of the vertical, depending on the machine model. The saddle is carried on, and can traverse, the main rails (5). The main rails are gibbed and geared to the upright bedways (6) for vertical movement. This arrangement allows you to feed main turret tools either vertically or horizontally, as compared to one direction on the horizontal turret lathe. Also, you can cut tapers by setting the turret slide at a suitable angle.

The side turret and side head of the vertical turret lathe correspond to the square turret and cross slide of the horizontal turret lathe. A typical vertical turret lathe has a system of feed trips and stops that functions similarly to those on a horizontal turret lathe. In addition, the machine has feed disengagement devices to prevent the heads from going beyond safe maximum limits and bumping into each other.

Vertical turret lathes have varying degrees of capabilities, including feed and speed ranges, angular turning limits, and special features such as threading.

You can expect to find a more coarse minimum feed on the earlier models of vertical turret lathes. Some models have a minimum of 0.008 inch per revolution of the table or chuck, while other models will go as low as 0.001 inch per revolution. The maximum feeds obtainable vary considerably also; however, this is usually less of a limiting factor in job setup and completion.

The speeds on any given vertical turret lathe tend to be much slower than those on a horizontal lathe. This reduction in speed is often required because of the large and oddly shaped sizes of work done on vertical turret lathes. A high speed can throw a workpiece out of the machine that may damage equipment and injure personnel.

One of the major differences between the lathes shown in figures 8-1 and 8-2 is in the method you will use to position the cutter to the work. On the lathe in figure 8-1, you will use a handwheel to position the

work manually. On the lathe in figure 8-2, you will use an electric drive controlled by a lever. When you move the feed control lever to the creep position, the turret head moves in the direction selected in increments as low as 0.0001 inch per minute. This creep feed is independent of table revolution and can be made with the table stopped.

An attachment available on some machines permits threading of up to 32 threads per inch with a single-point tool. The gears, as specified by the lathe manufacturer, are positioned in the attachment to provide a given ratio between the revolutions per minute of the table and the rate of advance of the tool.

The same attachment also lets the operator turn or bore an angle of 1° to 45° in any quadrant by positioning certain gears in the gear train. You can then engage the correct feed lever to cut the angle. Later in this chapter, we'll explain in detail how you turn tapers on a vertical turret lathe without this attachment.

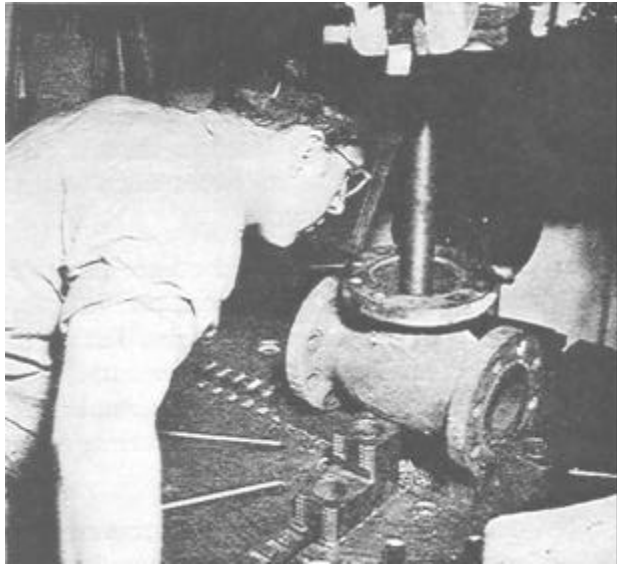
## **VERTICAL TURRET LATHE TOOLING**

The principles used to operate a vertical turret lathe are not very different from those for a horizontal turret lathe. The only significant difference is in the main turret. We said earlier that the main head corresponds to the hexagonal turret of the horizontal machine. You can feed it vertically toward the headstock (down), horizontally, or at an angle. To do this, you can engage both the horizontal and vertical feeds, or you can set the turret slide at an angle from the vertical and use only the vertical feed.

The tool angles used for the cutters of the vertical machine correspond to those on the horizontal turret lathe; they are an important factor in successful cutting. It is equally important to set cutters on center and maintain the clearance and rake angles in the process. Again, you must be sure the cutters are held rigidly.

In vertical turret lathe work, you must often use offset or bent-shank cutters, special sweep tools, and forming tools, particularly when you machine odd-shaped pieces. Many such cutting tools are designed to take advantage of the great flexibility of operation provided in the main head.

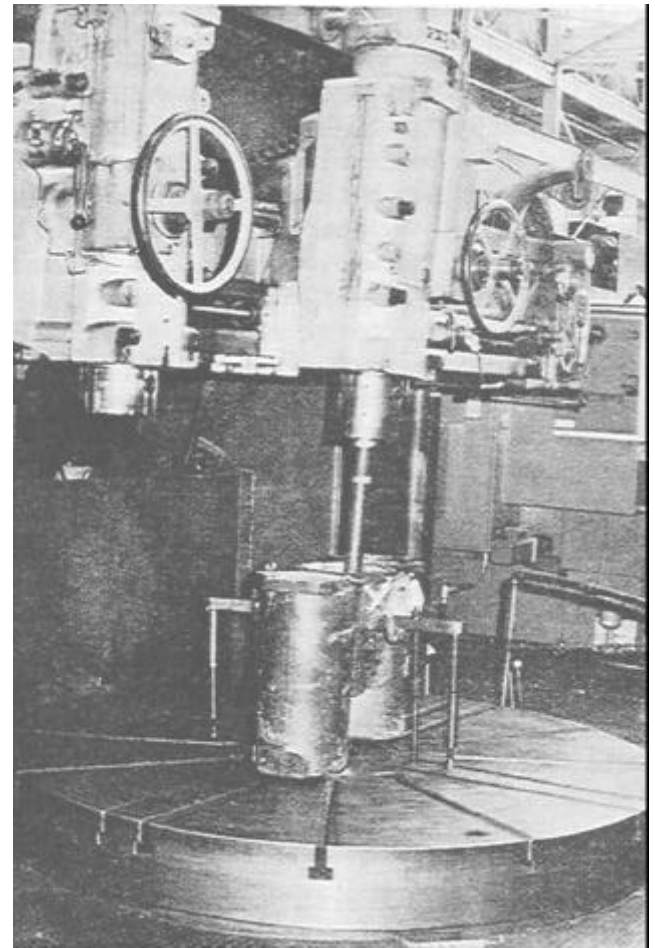
On a repair shop, you normally will use the vertical turret lathe for jobs other than straight



28.194

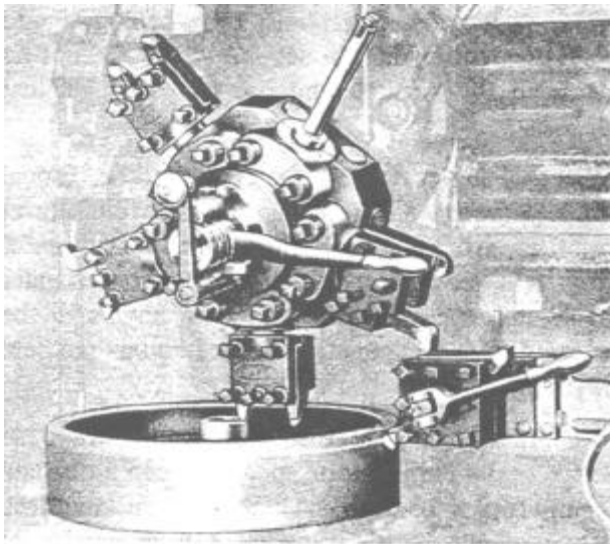
Figure 8-3.—Refacing a valve seat in a vertical turret lathe.

production work. For example, you can mount a large valve on the horizontal face of its worktable or chuck easier than on almost any other type of machine. For other examples, figure 8-3 shows a typical valve seat refacing job on a vertical turret lathe; figure 8-4 shows the double tooling principle applied to a machining operation, and figure 8-5 shows a straight boring bar used to bore a large saltwater strainer body.



28.461

Figure 8-5.—Straight boring bar being used to bore a large saltwater strainer.



28.195

Figure 8-4.—Double tooling.

## TAPER TURNING

The following information is based on a Bullard vertical turret lathe. (See fig. 8-1.)

There are several ways to cut a taper on a vertical turret lathe. You can cut a 45° taper with either a main turret-held cutter or a side head-held cutter if you engage the vertical and horizontal feeds simultaneously. To cut a taper of less than 30° with a main turret-held tool, set the turret slide for the correct degree of taper and use only the vertical feed for the slide. If you did this operation on an engine lathe, you would use the compound rest and advance the cutter by manual feed. On a vertical lathe, you would USC the vertical power feed.



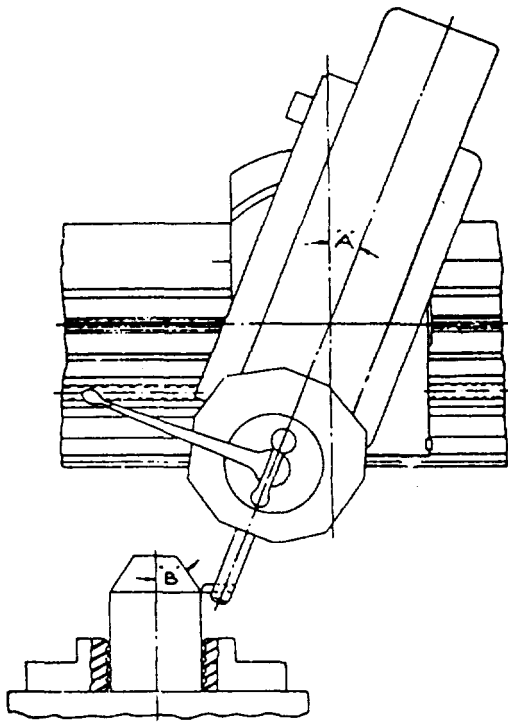


Figure 8-6.—Head setting for 30° to 45° angles.

If you swivel the main turret head on a vertical turret lathe, you can cut 30° to 60° angles without special attachments. To machine angles greater than 30° and less than 60° from the vertical, engage both the horizontal feed and the vertical feed simultaneously and swivel the head. Determine the angle to which you swivel the head in the following manner. For angles between 30° and 45°, swivel the head in the direction opposite to the taper angle you are turning, as shown in figure 8-6. The formula to determine the proper angle is  $A = 90^\circ - 2B^\circ$ . A sample problem from figure 8-6 follows:

Formula:  $A = 90^\circ - 2B^\circ$

Example:  $B = 35^\circ$

Therefore,  $A = 90^\circ - (2 \times 35^\circ)$

$A = 90^\circ - 70^\circ$

Angle:  $A = 20^\circ$

For angles between 45° to 60°, swivel the head in the same direction as the taper angle you are turning as shown in figure 8-7. The formula to determine the proper angle is  $A = 2B^\circ - 90^\circ$ . A sample problem from figure 8-7 follows:

Formula:  $A = 2B^\circ - 90^\circ$

Example:  $B = 56^\circ$

Therefore,  $A = (2 \times 56^\circ) - 90^\circ$

$A = 112^\circ - 90^\circ$

Angle:  $A = 22^\circ$

When you use the swivel method to turn a taper, use great care to set the slide in a true vertical position after you complete the taper work and before you use the main head for straight cuts. A very small departure from the true vertical will produce a relatively large taper on straight work. You may cut a dimension undersize before you are aware of the error.

Another way to cut tapers with either a main head-held or side head-held tool is to use a sweep-type cutter ground. Set it to the desired angle and feed it straight to the work to produce the desired tapered shape. This, of course, is feasible only for short taper cuts.

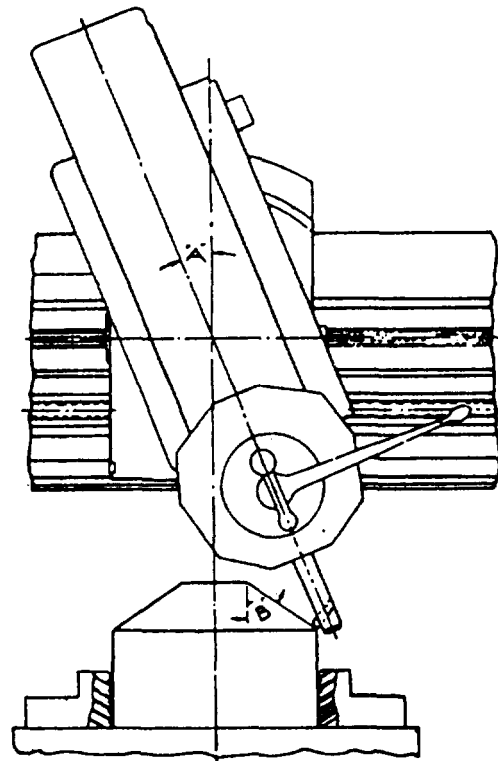


Figure 8-7.—Head setting for 45° to 60° angles.

## HORIZONTAL BORING MILL

The horizontal boring mill (fig. 8-8) consists of the four major elements described in the next paragraphs.

1. **BASE and COLUMN:** The base contains all the drive mechanisms for the machine and provides a platform that has precision ways machined lengthwise for the saddle. The column provides support for the head and has two rails machined the height of the column for full vertical travel of the head.

2. **HEAD:** The head contains the horizontal and auxiliary spindle and the mechanism to control them. The head also provides a station on which you can mount various attachments. The spindle feed and hand feed controls are contained in the head, along with the quick traverse turnstile and the spindle feed engagement lever.

3. **SADDLE and TABLE:** A large rectangular slotted table is mounted on a saddle that can be

traversed the length of the ways. T-slots are machined the entire length of the table. They are used to hold down work and various attachments, such as rotary table angle plates.

4. **BACKREST or END SUPPORT:** The backrest is mounted on the back end of the ways. It supports arbors and boring bars as they rotate and travel lengthwise through the work, such as the in-line boring of a pump casing or large bearing. The backrest blocks have an antifriction bearing; the boring bar passes through and rotates within this bearing. The backrest blocks travel vertically with the head.

Navy machine shops and shore repair activities usually have two types of horizontal boring mills: The table type is used for small work, and the floor type for large work. The floor type is the most common of the two. This machine is well suited for repair work where you often machine large, irregular parts.

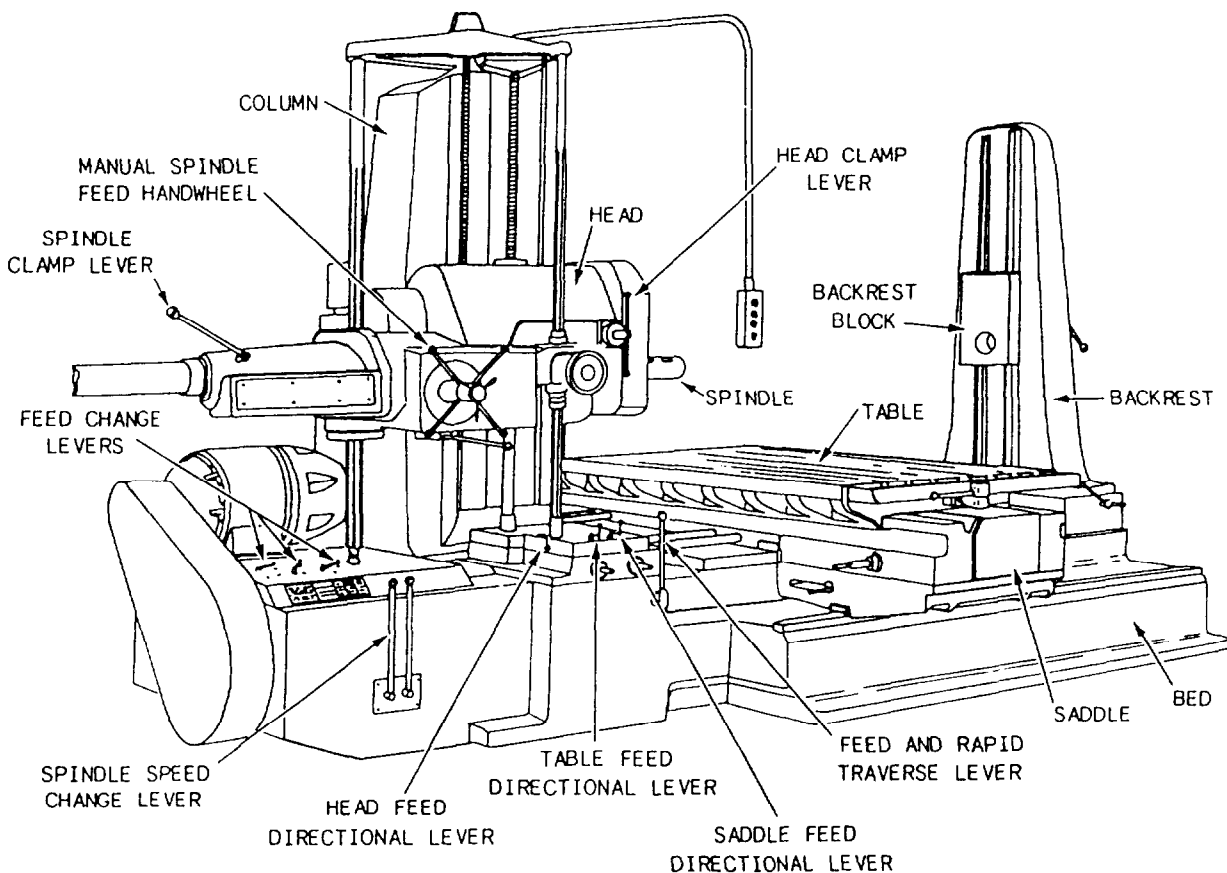


Figure 8-8.—Horizontal boring mill.

28.426

The reference to the size of horizontal boring mills differs with the manufacturer. Some use spindle size. For example, Giddings and Lewis model 300T has a 3-inch spindle. Others use the largest boring bar the machine will accept. In planning a job, consider both of these factors along with the table size and the height the spindle can be raised. Always refer to the technical manual for your machine.

It is most important that you set up the work correctly. Mistakes cost man-hours and material. Often you will find it's better to set up a casting to the layout lines than to a rough surface since the layout lines will always be used as a reference.

Be sure the holding clamps used to secure a piece of work are tight. If you use braces, place them so they can't come loose. Fasten blocks, stops, and shims securely. If a workpiece is not properly secured, you could ruin the material or the machine and injure personnel.

Different jobs may require different types of attachments. These attachments include angular milling heads, combination boring and facing heads, thread lead arrangements, and so forth. Boring heads are available in a variety of diameters. These boring heads are particularly useful to bore large diameter holes and face large castings. You also can use locally made collars, and you can use stub arbors to increase diameters.

## COMBINATION BORING AND FACING HEAD

The boring and facing head (fig. 8-9) is used to face and bore large diameters. It is mounted and bolted directly to the spindle sleeve, and it has a slide with automatic feed that holds the boring or facing tools. (This attachment can be fed automatically or positioned manually.) There are various sizes, but each is made and used similarly. The heads are balanced to permit high-speed operation with the tool slide centered. Whenever you use tools off center, be sure you counterbalance the head, or use it at lower speeds.

Generally, the boring and facing head will come equipped with several toolholders for single-point tools, a right-angle arm, a boring bar, and a boring bar holder that mounts on the slide. Use the following instructions to set up and operate the boring and facing head:

1. Retract the spindle of the machine into the sleeve. Engage the spindle ram clamp lever.
2. Disengage the overrunning spindle feed clutch to prevent accidental engagement of the spindle power feed while you mount the combination head on the machine. If the slide is centered and locked, you may run the spindle through it for use in other operations without removing the attachment, but be sure you disengage the spindle overrunning clutch again before you resume use of the slide.
3. Set the spindle for the speed to be used.
4. When the combination head is mounted on the sleeve, follow these steps: Before you shift the spindle back-gear to neutral, or make any spindle back-gear change, rotate the sleeve by joggling it until the heavy end of the head is down. Any spindle back-gear change requires a momentary shift to neutral which allows the sleeve to turn freely. The sleeve may rotate unexpectedly until the heavy end of the facing head is down, hitting you or the work.
5. Lift the head into position on the machine at the sleeve by inserting an eyebolt into the tapped hole in the top of the head.
6. To line up the bolt holes in the sleeve with those in the head, jog the spindle into position.

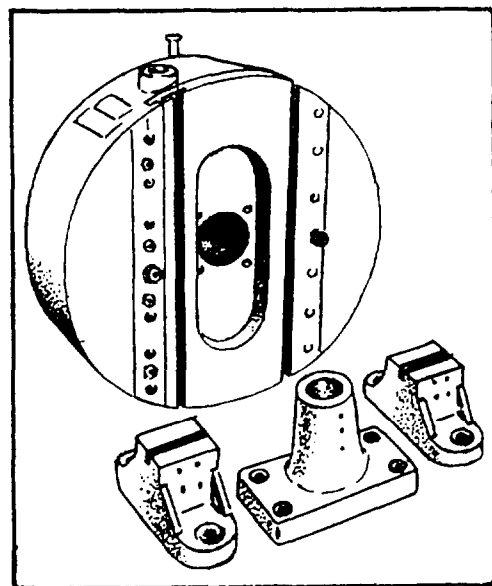


Figure 8-9.—Combination boring and facing head.

7. After you have tightened the mounting bolts, rotate the feed adjusting arm on the backing plate until the arm points directly toward the front.
8. Mount the restraining block on the head.
9. Set the slide manually; insert the tee-handled wrench into the slot in the slide adjusting dial and turn the wrench until the slide is positioned. The dial is graduated in thousandths of an inch and one complete turn equals a 0.125-inch movement of the slide.

After the slide is clamped in place, a spring-loaded safety clutch prevents movement of the slide or damage to the feed mechanism if the feed is inadvertently engaged. This is not provided to allow continuous operation of the head when the slide is clamped and the feed is engaged—it is a jamming protection only. A distinct and continuous ratcheting of the safety clutch warns you to unlock the slide or to disengage the feed. Do not confuse this warning with the intermittent ratcheting of the feed driving clutches as the head rotates. The same safety clutch stops the feed at the end of travel of the slide that prevents jamming of the slide or the mechanism through overtravel.

The slide directional lever is located on the backing plate beneath the feed adjusting arm. The arrows on the face of the selector show which way it should be turned to feed the slide in either direction. There are also two positions of the selector to disengage the slide feed. The direction of the spindle rotation has no effect on the direction of the slide feed.

The slide feed rate adjusting arm scale is graduated in 0.010-inch increments from 0.000 to 0.050 inch, but the first two increments are each 0.005 inch. Set the feed rate by turning the knurled adjusting arm to the desired feed in thousandths per revolution.

When you mount the single-point toolholders, be sure the tool point is on center or slightly below center so the cutting edge has proper clearance at the small diameters. You may damage the feed mechanism if you operate the head with the tool above center.

After you mount the facing head, perform the machining operation using the instructions in the operator's manual for your boring machine.

## RIGHT-ANGLE MILLING ATTACHMENT

The right-angle milling attachment is mounted over the spindle sleeve and bolted directly to the face of the head. It is driven by a drive dog inserted between the attachment and the spindle sleeve. This attachment lets you perform milling operations at any angle setting through a full 360°. You can perform boring operations at right angles to the spindle axis using either the head or the table feed depending on the position of the hole to be bored. You may use standard milling machine tooling held in the spindle by a drawbolt that extends through the spindle. Figure 8-10 shows a right-angle milling attachment.

## BORING MILL OPERATIONS

You can use the boring mills for drilling, reaming, and boring operations. You also can use it to face valve flanges, and bore split bearings and pump cylindrical liners. We will explain these in the next paragraphs.

### Drilling, Reaming, and Boring

Drilling and reaming operations are done the same way with both a horizontal boring mill and a radial drill. The major difference is the way the tool is held in the machine. It's horizontal in the horizontal boring mill (fig. 8-11) and vertical in the radial drill.

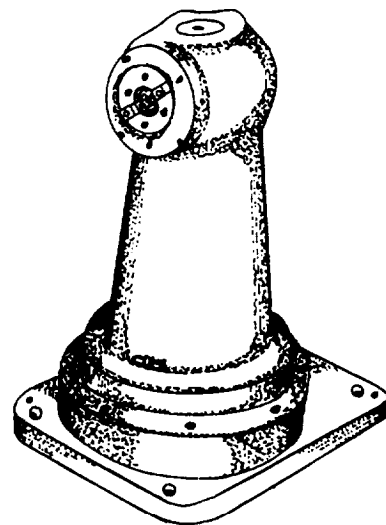
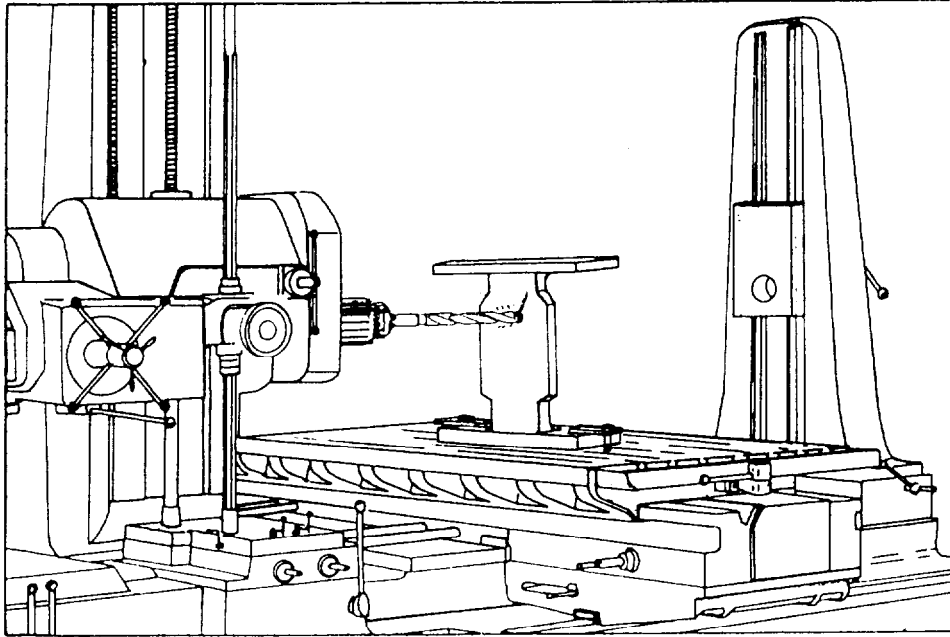


Figure 8-10.—Angular milling head.



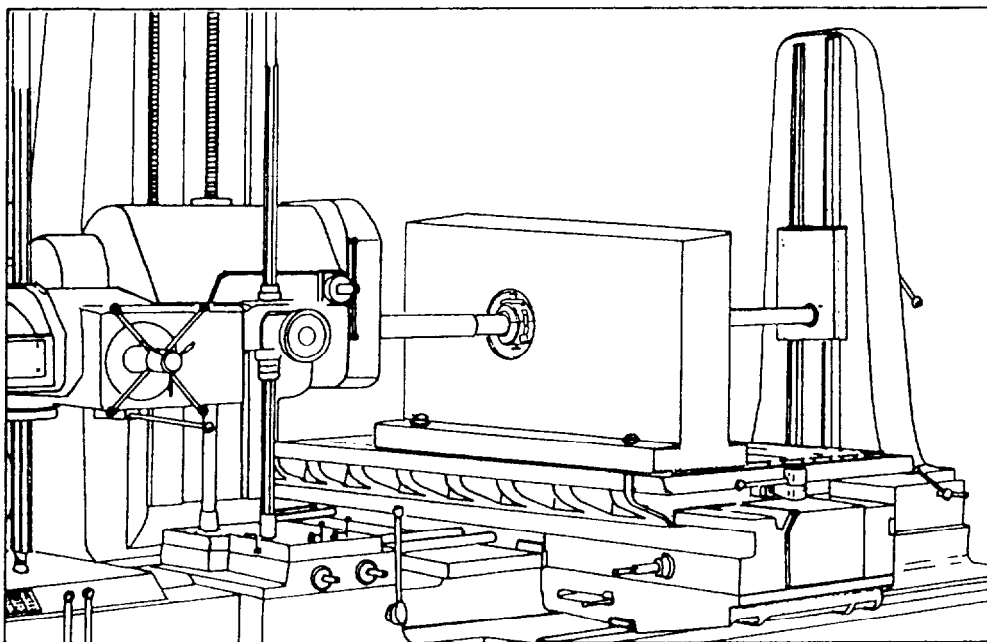
126.30

Figure 8-11.—Drilling in the horizontal boring mill.

### In-Line Boring

To set the horizontal boring machine for a line boring operation, insert a boring bar into the spindle and pass it through the work. The boring bar is supported on the foot end by the backrest assembly. Depending on the size of the bore, you can use either standard or locally manufactured tooling. The head

provides the rotary motion for the tools mounted in the boring bar. Align the work with the axis of the boring bar and bolt and/or clamp it to the table. In the cutting operation, the spindle usually moves while the work is held stationary. However, there may be times when you need to hold the bar in a fixed position and move the table lengthwise to complete the operation. (See fig. 8-12.)



28.280

Figure 8-12.—Boring bar driven by the spindle and supported in the backrest block.

The table can be power driven to provide travel perpendicular to the spindle. This makes it possible to bore, elongate, and slot when you use the table in conjunction with vertical movement of the head.

You can use a horizontal boring mill to line bore a split casing pump. You can use a standard boring bar, but it is preferable to manufacture dummy bearings and install them in the pump's bearing housings. After you have installed the dummy bearings, you will manufacture a boring bar to fit the bearings. You will then modify a tapered shank that fits the boring machine spindle so you can have a universal joint welded to it. The other end of the universal joint will be modified to accept the boring bar. By using a universal joint, the tapered shank will drive the boring bar without the pump being in perfect alignment. This is a long and complicated job, and it is best to consult with someone that has done it before you attempt it.

### **Reconditioning Split-Sleeve Bearings**

Practically all of the high-speed bearings the Navy uses on turbines are the babbitt-lined split-sleeve type. Once a bearing of this type has wiped, it must be reconditioned at the first opportunity. *Wiped* means the bearing has been damaged by an abnormal condition, such as insufficient lubrication. If it has wiped only slightly, it can probably be scraped to a good bearing surface and restored to service. If it is badly wiped, it will have to be rebabbitted and rebored, or possibly replaced. When you receive a wiped bearing for repair, use the following procedure and follow it as closely as possible:

1. Check the extent of damage and wear marks.
2. Take photos of the bearing to show the actual condition of the bearing and for future reference during machining and reassembly.
3. Check the shell halves for markings. A letter or number should be on each half for proper identification and assembly. (If the shell halves are not marked, mark them before you disassemble the bearing.)
4. Inspect the outer shell for burrs, worn ends, and the condition of alignment pins and holes.
5. Check the blueprint and job order to be sure the required information has been provided to you.

6. Be sure the actual shaft size has not been modified from the blueprint.

After you have completed these steps, send the bearing to the foundry to be rebabbitted. When you receive the rebabbitted bearing from the foundry, rough machine the bearing on a shaper to remove the excess babbitt extending above the horizontal flanges. Be extremely careful that you do not damage the base metal of the horizontal flanges during this operation. After rough machining, blue the remaining excess babbitt and scrape it until no more excess babbitt extends above the horizontal flanges.

Next, assemble the two half-shells and set them up on the horizontal boring mill. Check the spherical diameter of the bearing to ensure that it is not distorted beyond blueprint specifications. Generally, the words "BORE TRUE TO THIS SURFACE" are inscribed on the front face of the bearing shell. When you dial in the bearing, be sure to dial in on this surface.

When you have aligned the bearing in the boring mill, you can complete practically all the other operations without changing the setup. Bore the bearing to the finished diameter and machine the oil grooves as required by blueprint specifications. Figure 8-13 shows a line shaft bearing that has had the "cheeks" or oil reservoir grooves cut into it

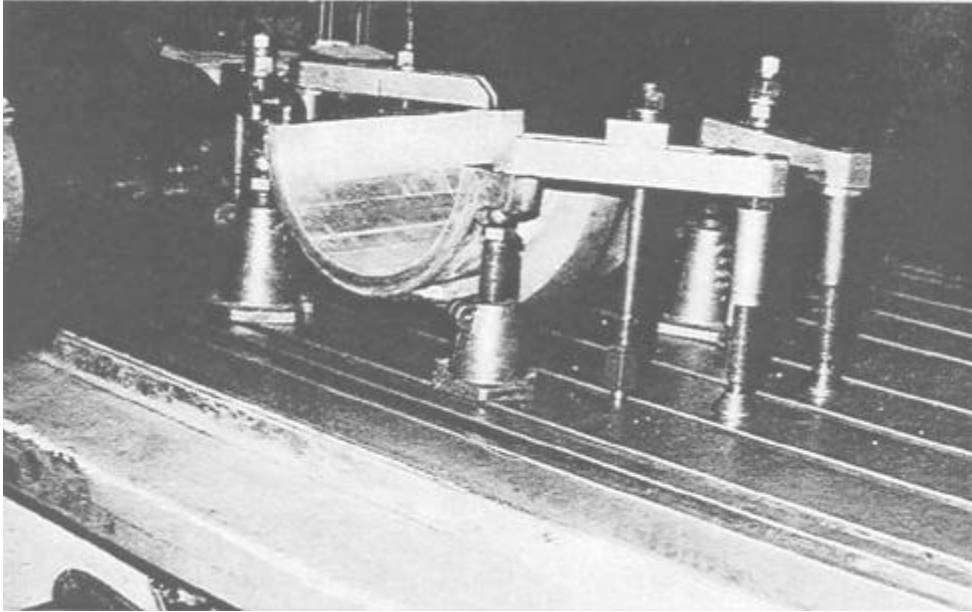
Oil is distributed through the bearing by oil grooves. These grooves may be of several forms; the two simplest are axial and circumferential. Sometimes circumferential grooves are placed at the ends of the bearings as a controlling device to prevent side leakage, but this type of grooving does not affect the distribution of lubricant.

When you machine grooves into a bearing, you must be careful in beveling the groove out into the bearing leads to prevent excess babbitt from clogging the oil passage. The type of grooves used in a bearing will not be changed from the original design.

When all machining is complete, both the repair activity and the ship's force determine that the bearing meets blueprint specifications and has a good bond between the shell and the babbitt metal.

### **Threading**

You can cut threads on horizontal boring mills that have a thread lead arrangement. On some machines, a thread lead arrangement is available with



28.462

Figure 8-13.—Line shaft bearing that has had the “cheeks” or oil reservoir grooves cut into it.

as many as 23 different threads, both standard and metric.

To cut threads with these machines, use a system of change gear combinations to obtain the different leads. Secure a single-point tool in a suitable toolholder and mount the toolholder in the spindle of the machine. While you cut threads, keep the spindle locked in place. The saddle, carrying the workpiece, advances at a rate determined by the change gear combination, Feeding, in conjunction with the spindle rotation in the low back gear range, produces the threads.

Cut the thread a little at a time in successive passes. The thread profile depends on how the cutting tool is ground. When you have completed the first pass, back the cutting tool off a few thousandths of an inch to avoid touching the workpiece on the return movement. Then, reverse the spindle driving motor. This causes the saddle direction to reverse while the

direction selection lever position remains unchanged. Allow the machine to run in this direction until the cutting tool has returned to its starting point. Advance the cutter to cut the thread a little deeper, set the spindle motor to run in forward, then make another cutting pass. Follow this procedure until the thread is completed. A boring bar with a micro-adjustable tool bit or a small precision head is ideal for this operation. It allows fast, easy adjustment of the tool depth and accuracy and control of the depth setting.

When you set up to cut threads, remove the thread lead access covers and set up the correct gear train combination as prescribed by the manufacturer’s technical manual. After you have set up the gear train, tighten the nuts on the arm clamp to lock the sliding arm. Be sure to replace the retaining washers on all the studs and lock them with the screws provided with the machine. Refer to the manufacturer’s technical manual for the machine you are using for the correct gear arrangement.





## CHAPTER 9

# SHAPERS, PLANERS, AND ENGRAVERS

### CHAPTER LEARNING OBJECTIVES

*Upon completing this chapter, you should be able to do the following:*

- *Identify and explain the use of shapers.*
- *Identify and explain the use of planers.*
- *Explain the use of pantographs.*

In this chapter we will discuss the major types of shapers, planers, and pantographs (engravers), and their individual components, cutters, and operating principles and procedures. A shaper has a reciprocating single-edged cutting tool that removes metal from the work as the work is fed into the tool. A planer operates on a similar principle except that the work reciprocates, and the tool is fed into the work. A pantograph is used primarily to engrave letters and designs on any type of material. The material can be flat, concave, convex, or spherical.

As with any shop equipment you must observe all posted safety precautions. Review safety precautions in your equipment operators manual and any chapters of *Navy Occupational Safety and Health (NAVOSH) Program Manual for Forces Afloat*, OPNAV Instruction 5100.19B, that pertain to the equipment.

### SHAPERS

A shaper has a reciprocating ram that carries a cutting tool. The tool cuts only on the forward stroke of the ram. The work is held in a vise or on the worktable, which moves at a right angle to the line of motion of the ram, permitting the cuts to progress across the surface being machined. A shaper is identified by the maximum size of a cube it can machine; thus, a 24-inch shaper will machine a 24-inch cube.

### HORIZONTAL SHAPERS

There are three distinct types of horizontal shapers: crank, geared, and hydraulic. The type depends on how the ram receives motion to produce its own reciprocating motion. In a crank shaper the ram is

moved by a rocker arm that is driven by an adjustable crankpin secured to the main driving gear. Quick return of the ram is a feature of a crank shaper. In a geared shaper, the ram is moved by a spur gear that meshes with a rack secured to the bottom of the ram. In a hydraulic shaper, the ram is moved by a hydraulic cylinder whose piston rod is attached to the bottom of the ram. Uniform tool pressure, smooth drive, and smooth work are features of the hydraulic shaper.

There are many different makes of shapers, but the essential parts and controls are the same on all. When you learn how to operate one make of shaper, you will not have any trouble learning to operate another make. Figure 9-1 is an illustration of a crank shaper found in shops in many Navy ships and shore repair facilities.

### Shaper Components

This section covers the construction and operation of the main components. They are the main frame assembly, drive assembly, crossrail assembly, toolhead assembly, and table feed mechanism. (See fig. 9-2.)

**MAIN FRAME ASSEMBLY.**—The main frame assembly consists of the base and the column. The base houses the lubricating pump and sump, which provide forced lubrication to the machine. The column contains the drive and feed actuating mechanisms. A dovetail slide is machined on top of the column to receive the ram. Vertical flat ways are machined on the front of the column to receive the crossrail.

**DRIVE ASSEMBLY.**—The drive assembly consists of the ram and the crank assembly. These parts convert the rotary motion of the drive pinion to the reciprocating motion of the ram. By using the

Deleted—No permission  
granted for electronic copy.

**Figure 9-1.—Standard shaper.**

adjustments provided, you can increase or decrease the length of stroke of the ram. You also can position the ram so the stroke is in the proper area in relation to the work.

You can adjust the **CRANKPIN**, which is mounted on the crank gear, from the center of the crank gear outward. The sliding block fits over the crankpin and has a freesliding fit in the rocker arm. If you center the crankpin (and therefore the sliding block) on the axis of the crank gear, the rocker arm will not move when the crank gear turns. But, if you set the crankpin off center by turning the stroke adjusting screw, any motion of the crank gear will cause the rocker arm to move. This motion is transferred to the ram through the ram linkage and starts the reciprocating motion of the ram. The distance the crankpin is set off center determines the length of stroke of the tool.

To position the ram, turn the ram positioning screw until the ram is placed properly with respect to the work. Specific procedures for positioning the ram and setting the stroke are in the manufacturer's technical manual for the specific machines you are using.

**CROSSRAIL ASSEMBLY.**—The crossrail assembly includes the crossrail, the crossfeed screw, the table, and the table support bracket (foot). (See fig. 9-1.) The crossrail slides on the vertical ways on the front of the shaper column. The crossrail apron (to which the worktable is secured) slides on horizontal ways on the crossrail. The crossfeed screw engages in a mating nut, which is secured to the back of the apron. You can turn the screw either manually or by power to move the table horizontally.

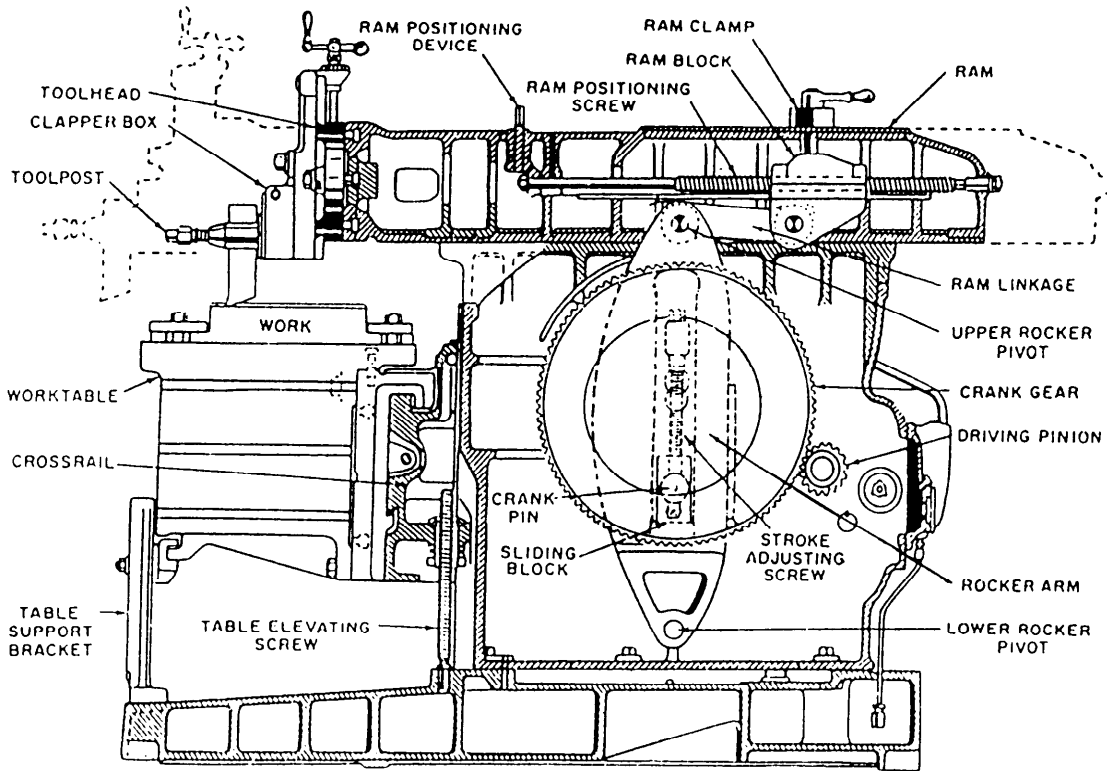


Figure 9-2.—Cross-sectional view of a crank-type shaper.

The worktable may be plain or universal, as shown in figure 9-3. Some universal tables can be swiveled only right or left, away from the perpendicular; others may be tilted fore or aft at small angles to the ram. T-slots on the worktables are for mounting the work or work-holding devices. A table support bracket (foot) holds the worktable and can be adjusted to the height required. The bracket slides along a flat surface on the base as the table moves horizontally. The table can be adjusted vertically by the table elevating screw (fig. 9-2).

Deleted—No permission granted for electronic copy.

**TABLE FEED MECHANISM.**—The table feed mechanism (fig. 9-4) consists of a ratchet wheel and

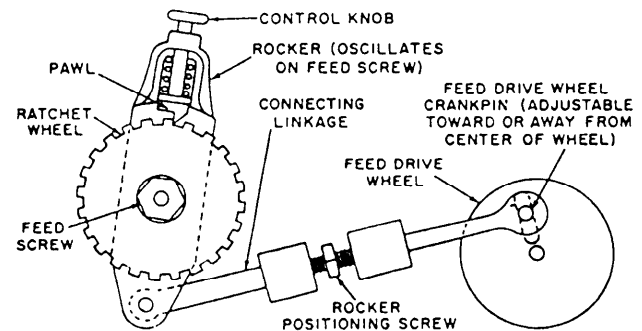


Figure 9-3.—Swiveled and tilted table.

Figure 9-4.—Mechanical table feed mechanism.

pawl, a rocker, and a feed drive wheel. The feed drive wheel is driven by the main crank. It operates similarly to the ram drive mechanism and converts rotary motion to reciprocating motion. As the feed drive wheel rotates, the crankpin (which can be adjusted off center) causes the rocker to oscillate. The straight face of the pawl pushes on the back side of a tooth on the ratchet wheel, turning the ratchet wheel and the feed screw. The back face of the pawl is cut at an angle to ride over one or more teeth as it is rocked in the opposite direction. To change the direction of feed, lift the pawl and rotate it one-half turn. To increase the rate of feed, increase the distance between the feed drive wheel crankpin and the center of the feed drive wheel.

The ratchet wheel and pawl method of feeding crank-type shapers has been used for many years. Relatively late model machines still use similar principles. Procedures used to operate feed mechanisms vary, so consult manufacturers' technical manuals for explicit instructions.

**TOOLHEAD ASSEMBLY.**—The toolhead assembly consists of the toolslide, the downfeed mechanism, the clapper box, the clapper head, and the toolpost at the forward end of the ram. You can swivel the entire assembly and set it at any angle not exceeding 50° on either side of the vertical. Raise or lower the toolhead by hand feed to make vertical cuts on the work. When you make vertical or angular cuts, swivel the clapper box away from the surface to be machined (fig. 9-5); otherwise, the tool will dig into the work on the return stroke.

### Vises and Toolholders

Vises and toolholders are not integral parts of the shaper as are the previously mentioned assemblies, so we will discuss them separately in the next paragraphs.

**WISE.**—The shaper vise is a sturdy mechanism secured to the table by T-bolts. It has two jaws, one stationary and the other movable, that can be drawn together by a screw (fig. 9-3). These jaws are longer and deeper than most similar devices to accommodate large work, and most of them have hardened steel jaws ground in place. Some shapers use a universal vise that can be swiveled in a horizontal plane from 0° to 180°. However, the jaws are usually set either parallel to, or at a right angle to, the stroke of the ram. Before you start work, be sure the vise is free from any obstruction that might keep the work from seating properly, and remove burrs, rough edges, and chips left from previous machining.

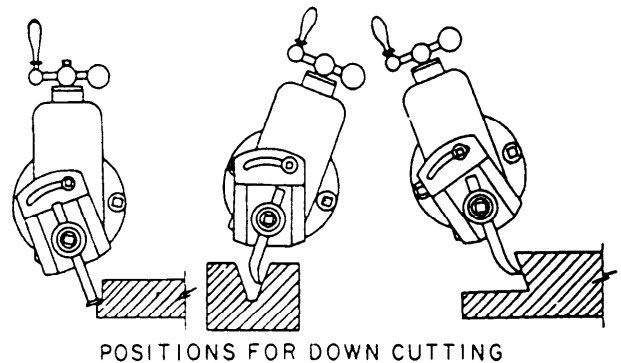
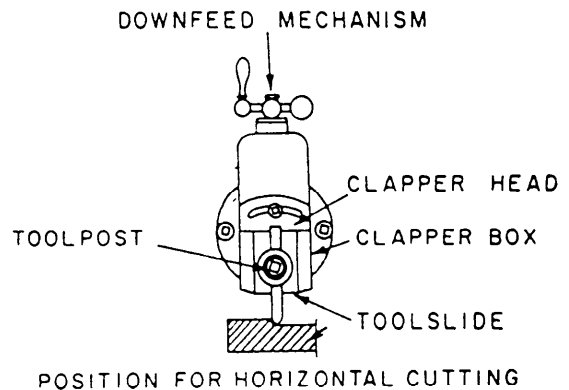


Figure 9-5.—Toolhead assembly in various positions.

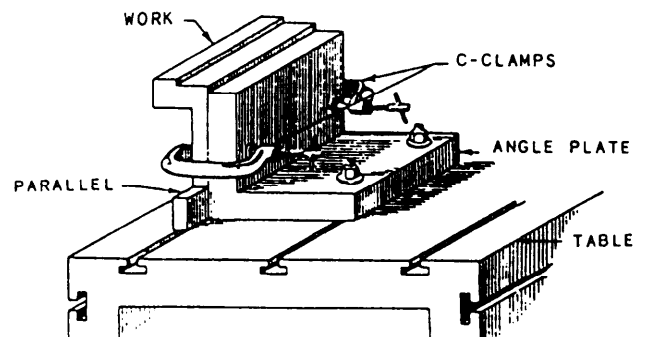


Figure 9-6.—Methods of holding and clamping.

You can set the work on parallels so the surface to be cut is above the top of the vise. You can use shaper holddowns to hold the work between the jaws of the vise. If the work is larger than the vise will hold, you can clamp it directly to the top or side of the machine table. When you must rotate work too large or awkward for a swivel vise, you can clamp it to a rotary table. You also may use V-blocks, angle plates, and C-clamps to mount work on shaper tables (fig. 9-6).

**TOOLHOLDERS.**—Various types of toolholders made to hold interchangeable tool bits are used to a great

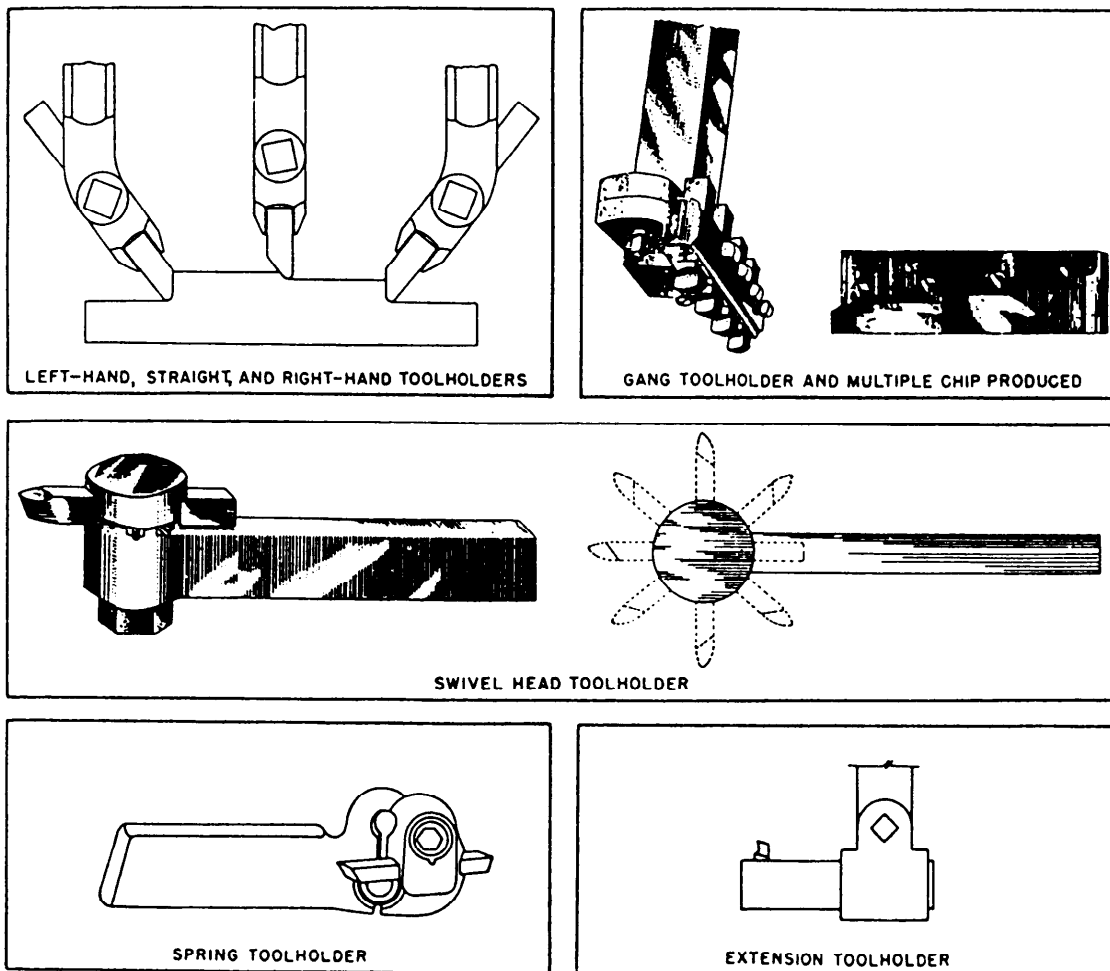


Figure 9-7.—Toolholders.

extent in planer and shaper work. Tool bits are available in different sizes and are hardened and cut to standard lengths to fit the toolholders. The toolholders that you will most commonly use are described in the following list and shown in figure 9-7:

1. Right-hand, straight, and left-hand toolholders used in most common shaper and planer operations.

2. Gang toolholders especially adapted to surface large castings. With a gang toolholder, you make multiple cuts with each forward stroke of the shaper. Each tool takes a light cut and there is less tendency to “break out” at the end of a cut.

3. Swivel head toolholders are universal, patented holders that you can adjust to place the tool in various radial positions. This feature allows you to convert the swivel head toolholder to a straight, right-hand, or left-hand holder at will.

4. Spring toolholders have a rigid, U-shaped spring that lets the holder cap absorb a considerable

amount of vibration. This toolholder is particularly good for use with formed cutters, which have a tendency to chatter and dig into the work.

5. Extension toolholders are adapted to cut internal keyways, splines, and grooves on the shaper. You can adjust the extension arm of the holder to change the exposed length and the radial position of the tool.

Chapter 5 contains procedures used to grind shaper and planer tool bits for various operations.

## Operations

Before beginning any job on the shaper, you should thoroughly study and understand the blueprint or drawing from which you are to work. In addition, you should take the following precautions:

- Make certain that the shaper is well oiled.
- Clean away **ALL** chips from previous work.

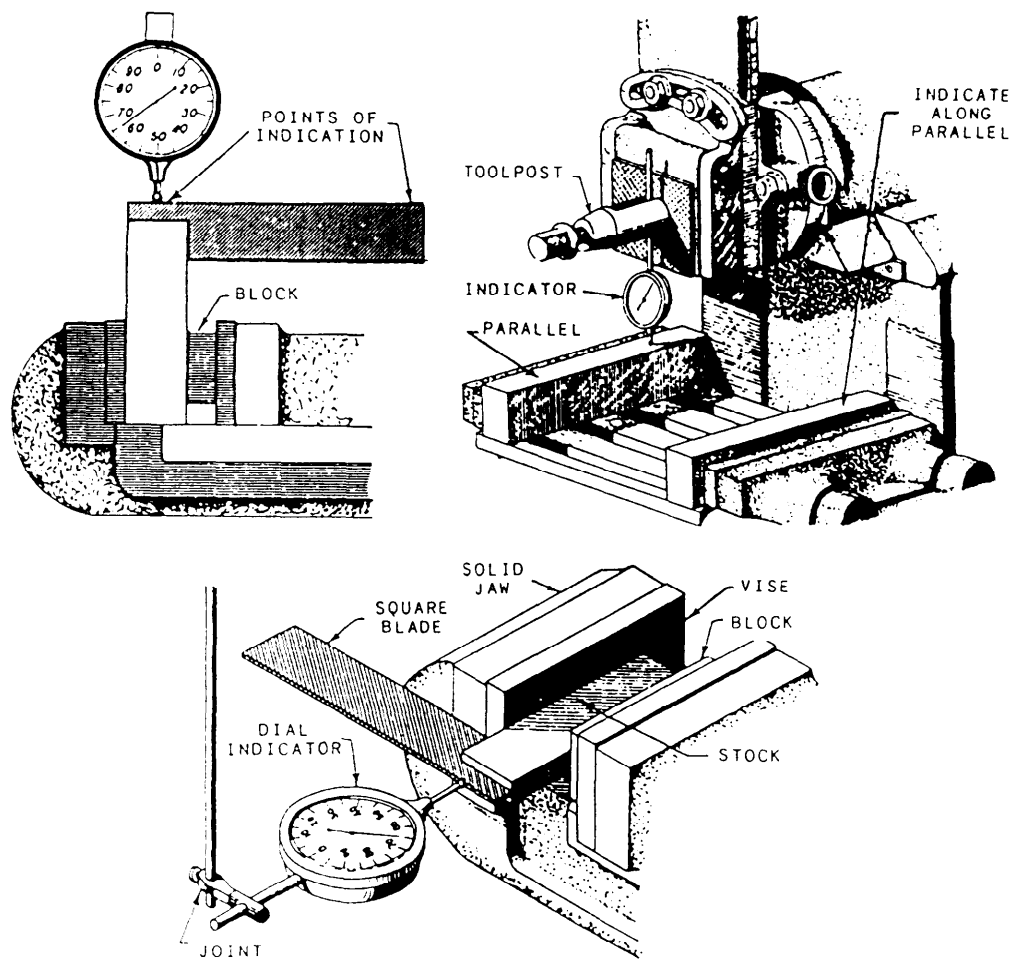


Figure 9-8.—Squaring the table and the vise.

- Be sure the cutting tool is set properly; otherwise, the tool bit will chatter. Set the toolholder so the tool bit does not extend more than about 2 inches below the clapper box.
- Be sure the piece of work is held rigidly in the vise to prevent chatter. You can seat the work by tapping it with a babbitt hammer.
- Test the table to see if it is level and square. Make these tests with a dial indicator and a machinist's square, as shown in figure 9-8. If either the table or the vise is off parallel, check for dirt under the vise or improper adjustment of the table support bracket.
- Adjust the ram for length of stroke and position. The cutting tool should travel 1/8 to 1/4 inch past the edge of the work on the forward stroke and 3/4 to 7/8 inch behind the rear edge of the work on the return stroke.

**SPEEDS AND FEEDS.**—You will set up the shaper to cut a certain material similar to the way you set up other machine tools, such as drill presses and lathes. First, determine the approximate required cutting speed, then determine and set the necessary machine speed to produce your desired cutting speed. On all of the machine tools we discussed in the previous chapters, cutting speed was directly related to the speed (rpm) of the machine's spindle. You could determine what spindle rpm to set by using one formula for all brands of a particular type of machine. The setup for a shaper is slightly different. You still relate cutting speed to machine speed through a formula, but the formula depends on the brand of machine that you operate. This is because some manufacturers use a slightly different formula to compute cutting speed than others. To determine the correct formula for your machine, consult the operator's manual provided by the manufacturer.

The following discussion explains basically how the operation of a shaper differs from the operation of other machine tools. It also explains how to determine

Table 9-1.—Recommended Cutting Speeds for Various Metals

Type of metal	Cutting speed (feet per minute)			
	Carbon steel tools		High-speed steel tools	
	Roughing	Finishing	Roughing	Finishing
Cast iron-----	30	20	60	40
Mild steel-----	25	40	50	80
Tool steel-----	20	30	40	60
Brass-----	} 75	100	150	200
Bronze-----				
Aluminum-----				

the cutting speeds and related machine speeds for a Cincinnati shaper.

When you determine the speed of the shaper required to produce a particular cutting speed, you must account for the shaper's reciprocating action. This is because the tool only cuts on the forward stroke of the ram. In most shapers the time required for the cutting stroke is 1 1/2 times that required for the return stroke. This means that in any one cycle of ram action the cutting stroke consumes 3/5 of the time and the return stroke 2/5 of the time. The formula used to determine machine strokes contains a constant that accounts for the time consumed by the cutting stroke.

To determine a cutting stroke value to set on the shaper speed indicator, first select a recommended cutting speed for the material you plan to shape from a chart such as the one shown in table 9-1.

Next, determine the ram stroke speed by using the following formula (remember, your machine may require a slightly different formula):

$$SPM = \frac{CS}{0.14 \times LOS}$$

Where: SPM = strokes of the ram per minute

CS = cutting speed in feet per minute

LOS = length of stroke in inches

0.14 = constant that accounts for partial ram cycle time and that converts inches to feet

Then, set the number of strokes per minute on the shaper by using the gear shift lever. A speed (strokes) indicator plate shows the positions of the lever for a variety of speeds. Take a few trial cuts and adjust the

ram speed as necessary until you obtain the desired cut on the work.

If after you have adjusted the ram speed, you want to know the exact cutting speed of the tool, use the following formula:

$$CS = SPM \times LOS \times 0.14$$

The speed of the shaper is regulated by the gear shift lever. The change gear box, located on the operator's side of the shaper, lets you change the speed of the ram and cutting tool according to the length of the work and the hardness of the metal. When the driving gear is at a constant speed, the ram will make the same number of strokes per minute regardless of whether the stroke is 4 inches or 12 inches. Therefore, to maintain the same cutting speed, the cutting tool must make three times as many strokes for the 4-inch cut as it does for the 12-inch cut.

Horizontal feed rates of up to approximately 0.170 inch per stroke are available on most shapers. There are no hard and fast rules for selecting a specific feed rate; you must rely on experience and common sense. Generally, to make roughing cuts on rigidly held work, set the feed as heavy as the machine will allow. For less rigid setups and for finishing, use light feeds and small depths of cut. It is best to start with a relatively light feed and increase it until you reach a desirable feed rate.

**SHAPING A RECTANGULAR BLOCK.**—An accurately machined rectangular block has square corners and opposite surfaces that are parallel to each other. In this discussion, faces are the surfaces of the block that have the largest surface area; the ends are the surfaces that limit the length of the block; and the sides are the surfaces that limit the width of the block.

You can machine a rectangular block in four setups if you use a shaper vise. Machine one face and an end in the first setup. Machine the opposite face and end in

the second setup. Then, machine the sides in two similar but separate setups. Align the vise jaws at right angles to the ram in both setups.

To machine a rectangular block from a rough casting, use the following sequence of operations:

1. Clamp the casting in the vise so a face is horizontally level and slightly above the top of the vise jaws. Allow one end to extend out of the side of the vise jaws enough so you can take a cut on the end without unclamping the casting. Now feed the cutting tool down to the required depth and take a horizontal cut across the face. After you have machined the face, readjust the cutting tool so it will cut across the surface of the end that extends from the vise. Use the horizontal motion of the ram and the vertical adjustment of the toolhead to move the tool across and down the surface of the end. When you have machined the end, check to be sure it is square with the machined face. If it is not square, adjust the toolhead swivel to correct the inaccuracy and take another light finishing cut down the end.

2. To machine the second face and end, turn the block over and set the previously machined face on parallels (similar to the method used in step 1). Insert small strips of paper between each corner of the block and the parallels. Clamp the block in the vise and use a soft-face mallet to tap the block down solidly on the parallels. When the block is held securely in the vise, machine the second face and end to the correct thickness and length dimensions of the block.

3. To machine a side, open the vise jaws so the jaws can be clamped on the ends of the block. Now set the block on parallels in the vise with the side extending out of the jaws enough to permit a cut using the downfeed mechanism. Adjust the ram for length of stroke and for position to machine the side and make the cut.

4. Set up and machine the other side as described in step 3.

**SHAPING ANGULAR SURFACES.**—You may use one of two methods to machine angular surfaces. For steep angles, such as on V-blocks, mount the work horizontally and swivel the toolhead to the desired angle. For small angles of taper, such as on wedges, mount the work on the table at the desired angle from the horizontal, or you can tilt the table if the shaper has a universal table.

To machine a steep angle using the toolhead swiveled to the proper angle, use the following sequence of operations:

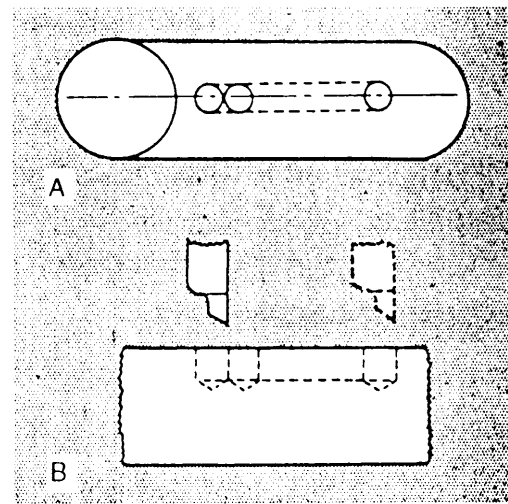


Figure 9-9.—Cutting a keyway in the middle of a shaft.

1. Set up the work as you would to machine a flat surface parallel with the table.

2. Swivel the toolhead (fig. 9-5) to the required angle. (Swivel the clapper box in the opposite direction.)

3. Start the machine and, using the manual feed wheel on the toolhead, feed the tool down across the workpiece. Use the horizontal feed control to feed the work into the tool and to control the depth of cut (thickness of the chip). (Because the tool is fed manually, be careful to feed the tool toward the work only during the return stroke.)

4. Set up and machine the other side as described in step 3.

**SHAPING KEYWAYS IN SHAFTS.**—Occasionally, you may use a shaper to cut a keyway in a shaft. Normally, you will lay out the length and width of the keyway on the circumference of the shaft. A centerline laid out along the length of the shaft and across the end of the shaft will make the setup easier (fig. 9-9, view A). Figure 9-9 also shows holes of the same diameter as the keyway width and slightly deeper than the key drilled into the shaft. These holes are required to provide tool clearance at the beginning and end of the cutting stroke. The holes shown in figure 9-9 are located to cut a blind keyway (not ending at the end of a shaft). If the keyway extends to the end of the shaft, only one hole is necessary.

To cut a keyway in a shaft, use the following sequence of operations:



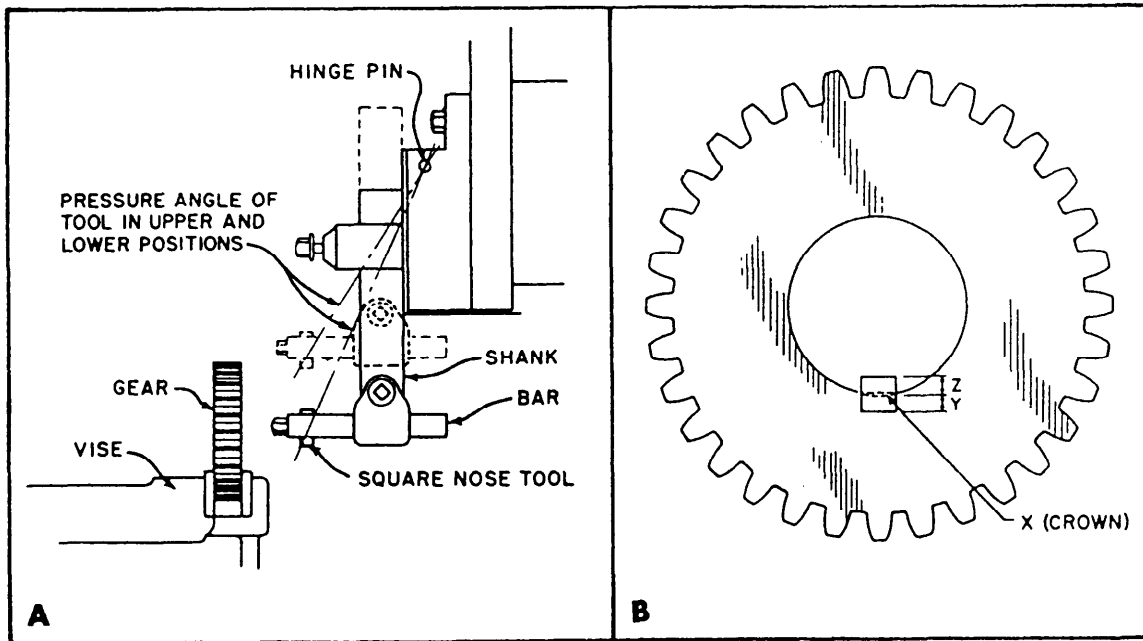


Figure 9-10.—Internal keyway: A. Shaping an internal keyway in a gear. B. Depth of keyways.

1. Lay out the centerline, the keyway width, and the clearance hole centers, as shown in view A of figure 9-9. Drill the clearance holes.

2. Position the shaft in the shaper vise or on the worktable so that it is parallel to the ram. Use a machinist's square to check the centerline on the end of the shaft to be sure it is perpendicular to the surface of the worktable. This ensures that the keyway layout is exactly centered at the uppermost height of the shaft and that the keyway is centered on the centerlines of the shaft.

3. Adjust the stroke and the position of the ram so the forward stroke of the cutting tool ends at the center of the clearance hole. (If you are cutting a blind keyway, be sure the cutting tool has enough clearance at the end of the return stroke so the tool will remain in the keyway slot.) (See view B of fig. 9-9.)

4. Position the work under the cutting tool so that the tool's center is aligned with the centerline of the keyway. (If the keyway is more than 1/2 inch wide, cut a slot down the center and shave each side of the slot until you get the proper width.

5. Start the shaper and use the toolhead slide to feed the tool down to the depth required, as shown on the graduated collar.

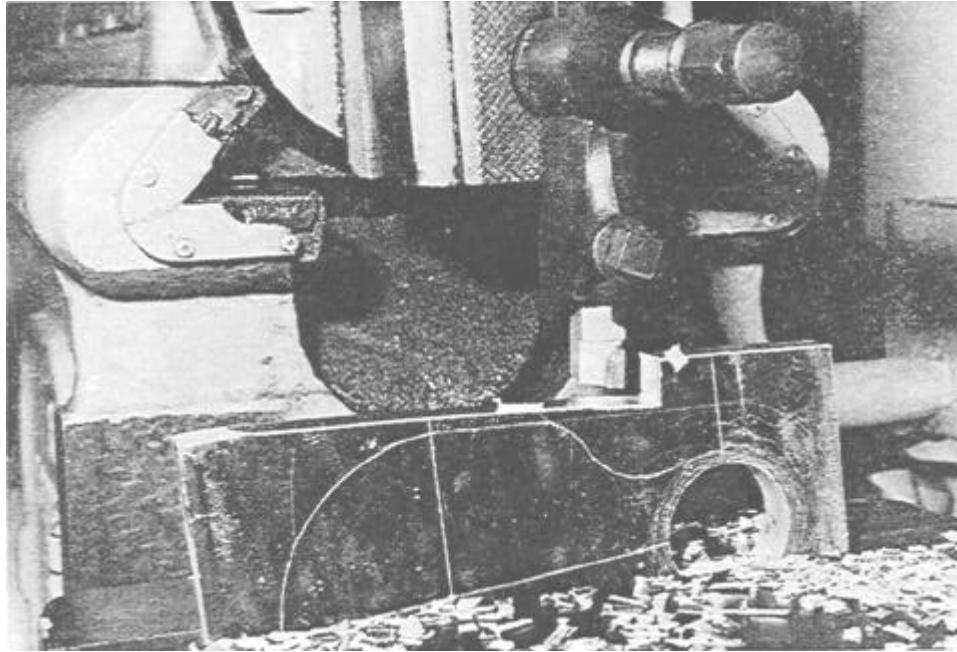
**SHAPING AN INTERNAL KEYWAY.**—To cut an internal keyway in a gear, you will have to use extension tools. These tools lack the rigidity of external

tools, and the cutting point will tend to spring away from the work unless you take steps to compensate. The keyway **MUST** be in line with the axis of the gear. Test the alignment with a dial indicator by taking a reading across the face of the gear. Swivel the vise slightly to correct the alignment if necessary.

The bar of the square-nose toolholder should not extend further than necessary from the shank; otherwise, the bar will have too much spring and will allow the tool to be forced out of the cut.

The extension toolholder should extend as far as practical below the clapper block, rather than in the position shown by the dotted lines in view A of figure 9-10. The pressure angle associated with the toolholder in the upper position may cause the pressure of the cut to open the clapper block slightly and allow the tool to leave the cut. In the lower position, the pressure angle is nearly vertical and prevents the clapper block from opening. Another method to prevent the clapper block from opening is to mount the tool in an inverted position.

With the cutting tool set up as in view A of figure 9-10, center the tool within the layout lines in the usual manner, and make the cut to the proper depth while feeding the toolhead down by hand. If you mount the tool in an inverted position, center the tool within the layout lines at the top of the hole, and make the cut by feeding the toolhead upward.



28.227

Figure 9-11.—Shaping irregular surfaces.

Figure 9-10, view B, shows the relative depths to which external and internal keyways are cut to produce the greatest strength. When you cut a keyway in the gear, set the downfeed micrometer collar to zero at the point where the cutting tool first touches the edge of the hole. First, remove the crown, X, from the shaft to produce a flat whose width is equal to the width of the key. Then, make a cut in the shaft to depth 2. The distance of Y plus Z is equal to the height of the key that is to lock the two parts together.

**SHAPING IRREGULAR SURFACES.**—To machine irregular surfaces, use form ground tools and feed the cutting tool vertically by hand while using power feed to move the work horizontally. A gear rack is an example of work you might shape by using form tools. You can use the toolhead feed to shape work such as concave and convex surfaces. When you machine irregular surfaces, you have to pay close attention because you control the cutting tool manually. Also, you should lay out the job before you machine it to provide reference lines. You also should take roughing cuts to remove excess material to within 1/16 inch of the layout lines.

You can cut **RACK TEETH** on a shaper as well as on a planer or a milling machine. During the machining operation, you may either hold the work in the vise or clamp it directly to the worktable. After you mount and position the work, use a roughing tool to rough out the

tooth space in the form of a plain rectangular groove, then finish it with a tool ground to the tooth's finished contour and size.

To machine a rack, use the following sequence of operations:

1. Clamp the work in the vise or to the table.
2. Position a squaring tool, which is narrower than the required tooth space, so the tool is centered on the first tooth space to be cut.
3. Set the graduated dial on the crossfeed screw to zero, and use it as a guide to space the teeth.
4. Move the toolslide down until the tool just touches the work, and lock the graduated collar on the toolslide feed screw.
5. Start the machine and feed the toolslide down slightly less than the whole depth of the tooth, using the graduated collar as a guide, and rough out the first tooth space.
6. Raise the tool to clear the work and move the crossfeed a distance equal to the linear pitch of the rack tooth by turning the crossfeed lever. Rough out the second tooth space, and repeat this operation until all spaces are roughed out.

7. Replace the roughing tool with a tool ground to size for the desired tooth form, and align the tool.
8. Adjust the work so the tool is properly aligned with the first tooth space that you rough cut.
9. Set the graduated dial on the crossfeed screw at zero and use it as a guide to space the teeth.
10. Move the toolslide down until the tool just touches the work, and lock the graduated collar on the toolslide feed screw.
11. Feed the toolslide down the whole depth of the tooth, using the graduated collar as a guide, and finish the first tooth space.
12. Raise the tool to clear the work and move the crossfeed a distance equal to the linear pitch of the rack tooth by turning the crossfeed lever.
13. Finish the second tooth space; then measure the thickness of the tooth with the gear tooth vernier caliper. Adjust the toolslide to compensate for any variation indicated by this measurement.
14. Repeat the process of indexing and cutting until you have finished all of the teeth.

Use the following procedure to machine irregular surfaces that have **CONVEX** and/or **CONCAVE** radii. On one end of the work, lay out the contour of the finished job. When you shape to a scribed line, as shown in figure 9-11, it is good practice to rough cut to within 1/16 inch of the line. You can do this by making a series of horizontal cuts using automatic feed and removing excess stock. Use a left-hand cutting tool to remove stock on the right side of the work and a right-hand cutting tool to remove stock on the left side of the work. When 1/16 inch of metal remains above the scribed line, take a file and bevel the edge to the line. This will eliminate tearing of the line by the breaking of the chip. Starting at the right-hand side of the work, set the automatic feed so the horizontal travel is rather slow. Feed the tool vertically by hand to take finishing cuts and produce a smooth contoured surface.

## VERTICAL SHAPERS

The vertical shaper (slotter), shown in figure 9-12, is especially adapted to slot internal holes or keyways with angles up to 10°. The vertical ram (fig. 9-12) reciprocates up and down. To do angular slotting, tilt the ram to the required angle. Different models of machines will have their control levers in different

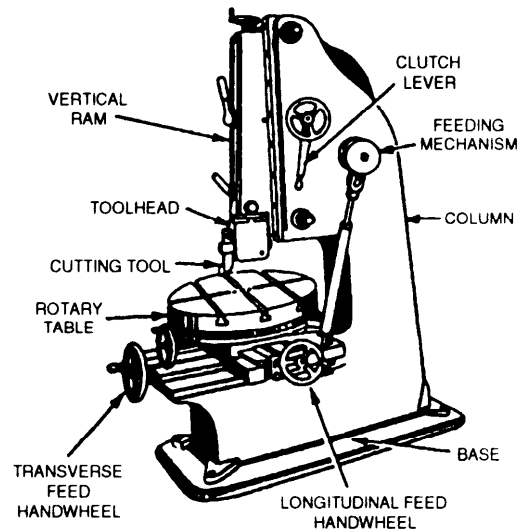


Figure 9-12.—Vertical shaper.

locations, but all of them will have the same basic functions and capabilities. The speed of the ram is adjustable to allow for the various materials and machining requirements. Speed is expressed in either strokes per minute or feet per minute, depending on the particular model. You also may adjust the length and the position of the ram stroke. Automatic feed for the cross and longitudinal movements, and on some models the rotary movement, is provided by a ratchet mechanism, gear box, or variable speed hydraulic system. Again, the method depends on the model. You may hold the work in a vise mounted on the rotary table, clamp it directly to the rotary table, or hold it by special fixtures. The square hole in the center of a valve handwheel is an example of work that can be done on a machine of this type. The sides of the hole are cut on a slight angle to match the angled sides of the square on the valve stem. If this hole were cut by using a broach or an angular (square) hole drill, the square would wear prematurely due to the reduced area of contact between the straight and angular surfaces.

## PLANERS

Planers are rigidly constructed machines, particularly suitable for machining long cuts on large and heavy work. In general, planers and shapers can be used for similar operations. However, the reciprocating motion of planers is provided by the worktable (platen), while the cutting tool is fed at a right angle to this motion. Like the shaper, the planer cuts only on the forward stroke, after which the table makes a quick return to bring the work into position for the next cut.

Deleted—No permission  
granted for electronic copy.

**Figure 9-13.—Open side planer.**

The size of a planer is determined by the size of the largest work that can be clamped and machined on its table; thus, a 30 inch by 30 inch by 6 foot planer is one that can accommodate work up to these dimensions.

Planers are divided into two general classes, the **OPEN** side type and the **DOUBLE HOUSING** type.

Planers of the open side type (fig. 9-13) have a single vertical housing to which the crossrail is attached. The advantage of this design is that you can plane work that is too wide to pass between the uprights of a double housing machine.

In the double housing planer, the worktable moves between two vertical housings to which a crossrail and toolhead are attached. The larger machines are usually equipped with the cutting heads mounted to the crossrail as well as a side head mounted on each housing. With this setup, it is possible to machine simultaneously both

the side and the top surfaces of work mounted on the table.

### **MAJOR COMPONENTS**

All planers consist of five principal parts: the bed, table, columns, crossrail, and toolhead.

The bed is a heavy, rigid casting that supports the entire piece of machinery. The ways on which the planer table rides are on the upper surface of the bed.

The table is a flat, cast-iron surface to which the work is mounted. The planer table has T-slots and reamed holes that are used to fasten work to the table. On the underside of the table there is usually a gear train or a hydraulic mechanism that gives the table its reciprocating motion.

The columns of a double housing planer are attached to either side of the bed and at one end of the planer. On the open side planer there is only one column

or housing attached on one side of the bed. The columns support and carry the crossrail.

The crossrail serves as the rigid support for the toolheads. The vertical and horizontal feed screws on the crossrail are used to adjust the machine for work of various sizes.

The toolhead is similar to that of the shaper in construction and operation.

All sliding surfaces subject to wear are provided with adjustments. Keep the gibes adjusted to take up any looseness due to wear.

## OPERATING THE PLANER

Before you operate a planer, be sure you know where the various controls are and what function each controls. Once you master one model or type of planer, you will have little difficulty with others. However, always look in the manufacturer's technical manual for specific operating instructions on the machine you are using. The following sections contain general information on planer operation.

### Table Speeds

The table speeds are controlled by the start-stop lever and the flow control lever (fig. 9-13). Two ranges of speeds and a variation of speeds within each range are available. Use the start-stop lever to select the speed range (**LOW-MAXIMUM CUT** or **HIGH-MINIMUM CUT**), and use the flow control lever to vary the speeds within each range. As the flow control lever is moved toward the right, the table speed will gradually increase until it reaches the highest possible speed.

Use the **LOW** speed range to shape hard materials that require high cutting force at low speeds. Use the **HIGH** range for softer materials that require less cutting force but higher cutting speeds.

The **RETURN** speed control provides two return speed ranges (**NORMAL** and **FAST**). In **NORMAL**, the return speed varies in ratio with the cutting speed selected. In **FAST**, the return speed remains constant (full speed), independent of the cutting speed setting.

### Feeds

Adjust the feed by turning the handwheel that controls the amount of toolhead feed. Turn it counterclockwise to increase the feed. You can read the amount of feed on the graduated dials at the operator's end of the crossrail feed box. Each graduation indicates a movement of 0.001 inch.

To control the toolhead's direction of feed (right or left, up or down), use the lever on the rear of the feed box. To engage or disengage the vertical feed, use the upper of the two levers on the front of the feed box. To give a downward feed to the toolhead, shift the rear, or directional, lever to the down position and engage the clutch lever by pressing it downward. To give an upward feed, shift the directional lever to the up position.

Use the lower clutch lever on the front of the feed box to engage the horizontal feed of the toolhead. When the directional lever on the rear of the box is in the down position, the head is fed toward the left. When it is in the up position, the head is fed toward the right.

Use the ball crank on top of the vertical slide (toolhead feed) to hand feed the toolslide up or down. A graduated dial directly below the crank indicates the amount of travel.

Use the two square-ended shafts at the end of the crossrail to move the toolhead by hand. To use either of the shafts, put a handcrank on the square end, ensure that the directional lever on the rear of the feedbox is in the center, or neutral, position, and then turn the shaft. The upper shaft controls vertical movement. The lower shaft controls horizontal movement.

Use lock screws on both the cross-slide saddle and the vertical slide to lock these slides in position after you make the tool setting.

The planer side head has powered vertical feed and hand-operated horizontal feed. Use a lever on the rear of the side head feed box to control the vertical feed, both engagement and direction. Control vertical traverse by turning the square shaft that projects from the end of the feed box. Use the bell crank at the end of the toolhead slide to control horizontal movement, both feed and traverse.

### Rail Elevation

To raise or lower the crossrail, use the handcrank on the squared shaft projecting from the rear of the rail brace. To move the rail, first loosen the two clamp nuts at the rear of the column and the two at the front; then use the handcrank to move the rail to the desired height. Be sure to tighten the clamp nuts before you do any machining.

On machines that have power rail elevation, a motor is mounted within the rail brace and connected to the elevating mechanism. Rush buttons control the motor's forward and reverse operation. The clamp nuts described in the previous paragraph have the same use on all machines whether they use manual or power elevation.

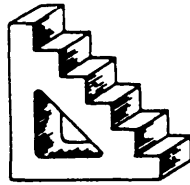


Figure 9-14.—Step block.

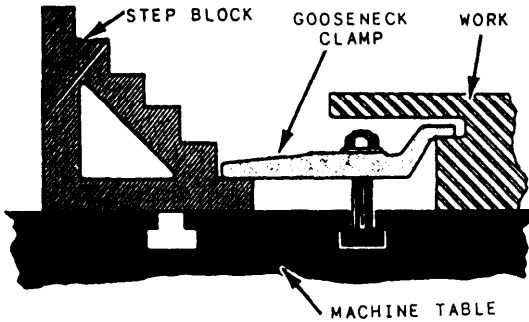


Figure 9-15.—Application of step block and clamp.

## Holding the Work

The various accessories used to hold planer or shaper work may make the difference between a superior job and a poor job. There are no set rules on the use of planer accessories to clamp down a piece of work—results will depend on your ingenuity and experience.

One way to hold down work on the worktable is by using clamps attached to the worktable by bolts inserted in the T-slots. Figure 9-14 shows a step block that you can use with clamps when you need to clamp an irregularly shaped piece of work to the planer table. One way to do this is illustrated in figure 9-15; where an accurately machined step block is used with a gooseneck clamp. Figure 9-16 illustrates correct and incorrect ways to apply clamps.

You can use jacks of different sizes to level and support work on the planer table. The conical point screw (fig. 9-17, B) replaces the swivel pad-type screw for use in a corner. You can use extension bases (fig. 9-17, C, D, E, and F) to increase the effective height of the jack

## PANTOGRAPHS

The pantograph (engraving machine) is essentially a reproduction machine. It is used in the Navy to engrave letters and numbers on label plates, to engrave and graduate dials and collars, and in other work that requires the exact reproduction of a flat pattern on the

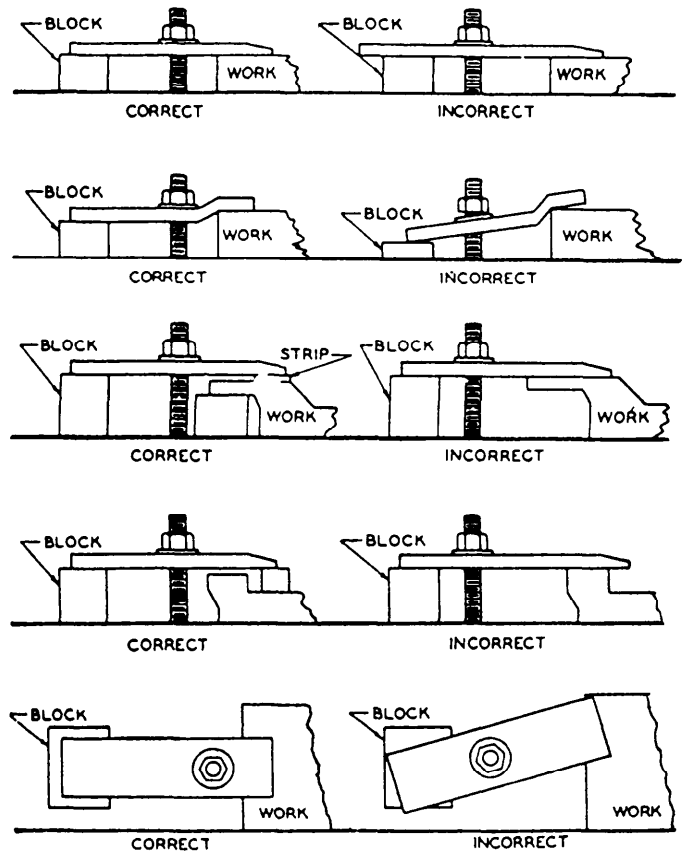


Figure 9-16.—Correct and incorrect clamp applications.

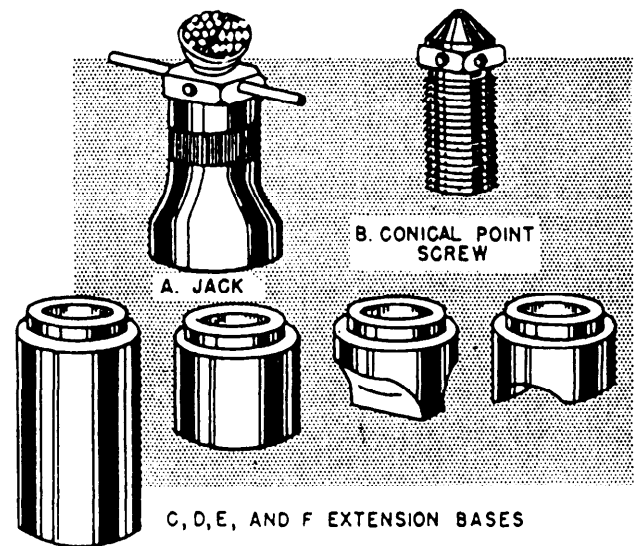


Figure 9-17.—Planer jack and extension bases.

workpiece. You can use it to engrave flat and uniformly curved surfaces.

There are several different models of engraving machines that you may have to operate. Figure 9-18 shows one model that mounts on a bench or a table top

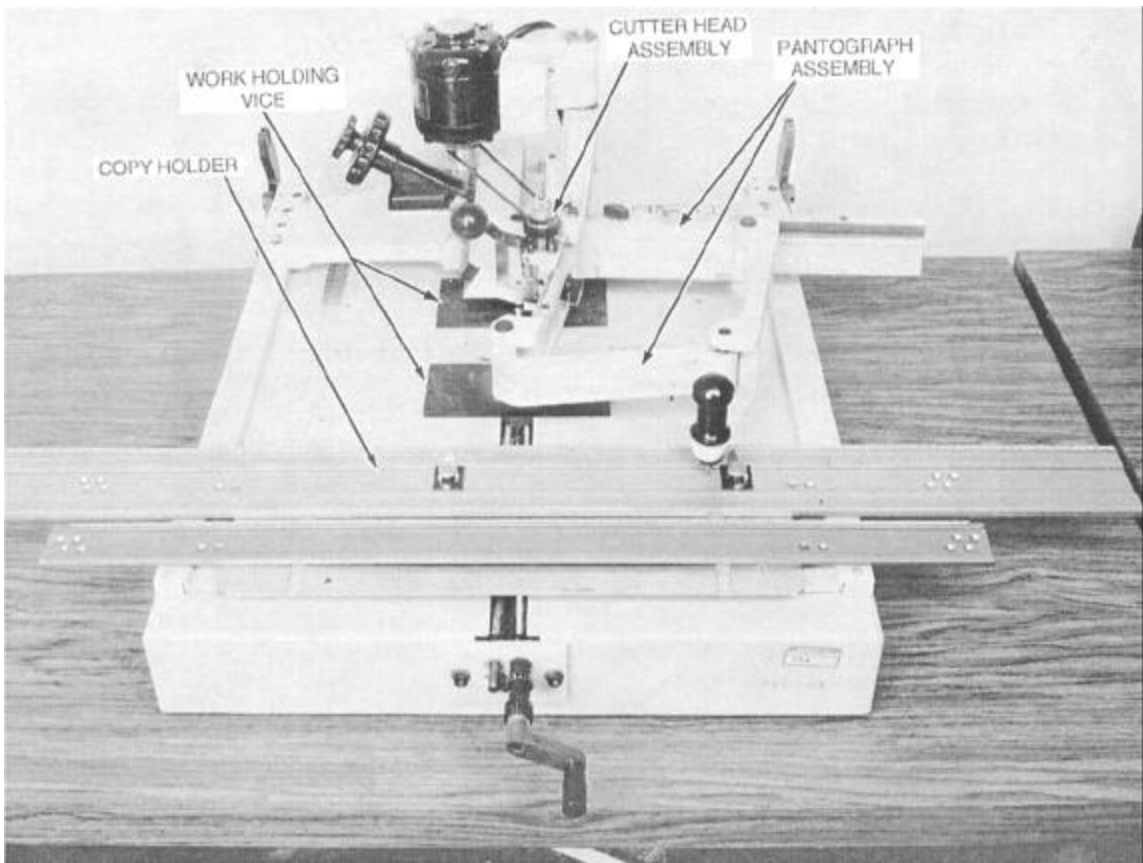


Figure 9-18.—Engraving machine.

28.473



Figure 9-19.—Computer-controlled engraving machine.

28.474

and is used primarily to engrave small items. This particular machine is manufactured by the New Hermes Inc. It's ratio settings range from 2 to 8. That means the largest finished engraving pattern you can produce from

a given master will be one-half the size of the original master character.

Figure 9-19 shows a computer-controlled engraving machine. There are several software packages available

for it. You can do anything from regular engraving to engravings of images produced on the computer screen. Once you learn to operate this machine, you will be able to complete jobs at a much faster pace than you did with a manual engraving machine.

Most computer-controlled engraving machines are on tenders and at shore repair facilities. We will not discuss setup and training on those machines because it is included in the purchase price and provided by the manufacturer. However, nearly all Navy ships have an engraving machine similar to the one shown in figure 9-18. You will need training on it, so we will discuss it in detail.

## MAJOR COMPONENTS

The pantograph engraving machine, shown in figure 9-18, consists of four principal parts: pantograph assembly, cutterhead assembly, worktable, and copyholder. We will discuss these parts in the following paragraphs:

1. **PANTOGRAPH ASSEMBLY:** The pantograph assembly (fig. 9-18) consists of moveable bars used to set the reduction and to hold the stylus and cutterhead. The relationship between movement of the stylus point and movement of the cutter is governed by the relative positions of where the bars and the cutter are set.

2. **CUTTERHEAD ASSEMBLY:** The cutterhead assembly (fig. 9-18) houses the precision cutter spindle. You can adjust spindle speeds by changing the pulley drives located between the motor and the spindle. There is a vertical feed lever at the head of the cutter. It provides a range of limited vertical movement from 1/16 inch to 1/4 inch to prevent the cutter from breaking when it feeds into work. A plunger locks the spindle for flat surface engraving or releases it for floating vertical movement of 1/2 inch with the forming guide on curved work. The cutterhead assembly is hinged to permit spindle removal from the side. This makes it unnecessary to disturb any work by lowering the table.

3. **WORKHOLDING VISE:** The workholding vice shown in figure 9-18 is used to hold flat material or nametags. For odd-shaped jobs, there are several fixtures available that mount to the machine base. You can buy these fixtures from your machine's manufacturer.

4. **COPYHOLDER:** The copyholder shown in figure 9-18 is a dovetailed slot used to hold the master characters commonly known as copy.

## SETTING COPY

Lettering used with an engraver is known by various terms, but the Navy uses the term copy to designate the characters used as sample guides. Copy applies specifically to the standard brass letters, or type, that are set in the copyholder of the machine and guide the pantograph in reproducing that copy. Shapes, as distinguished from characters, are called templates or masters.

Copy is not self-spacing; therefore, you should adjust the spaces between the characters by inserting suitable blank spacers furnished with each set of copy. Each line, when set in the copyholder, should be held firmly between clamps.

After setting up the copy in the holder, and before engraving, be sure that the holder is firmly set against the stop screws in the copyholder base. This ensures that the holder is square with the table. Do not disturb these stops; they were properly adjusted at the factory, and any change will throw the copyholder out of square with the table. The worktable T-slots are parallel with the table's front edge, making it easy to set the work and the copy parallel to each other.

## SETTING THE PANTOGRAPH

The correct setting of the pantograph is determined from the ratio of (1) the size of the work to the size of the copy layout, or (2) the desired size of engraved characters to the size of the copy characters. This ratio is called a reduction. As we stated before a 2 to 1 reduction results in an engraved layout one-half the size of the master character; an 8 to 1 reduction results in an engraved layout one-eighth the size of the master character.

If a length of copy is 10 inches and the length of the finished job is to be 2 inches, divide the length of the job into the length of the copy:

$$10 \div 2 = 5 \text{ inches}$$

For this job, set the scales (fig. 9-18) at 5.

If the length of the copy is 11 inches and the length of the finished job is to be 4 inches, the reduction is

$$11 \div 4 = 2.75$$

After you have set a reduction, check the pantograph. First, place a point into the spindle; then raise the table until the point barely clears the table. Next, trace along an edge of a copy slot in the copyholder with the tracing stylus. If the cutter point follows parallel to the workholding vise, the reduction is proper. If the point forms an arc or an angle, recalculate the setting and reset the machine.



Table 9-2.—Cutter Speeds

Materials and Feeds	Cutter diameter (at cutting point)								
	1/32"	1/16"	1/8"	3/16"	1/4"	5/16"	3/8"	7/16"	1/2"
	Speeds (rpm)								
Hardwood (650-800 ft./min.)----	10,000 to 20,000	10,000 to 20,000	10,000 to 20,000	10,000 to 20,000	10,000 to 20,000	9,000	8,000	7,000	6,000
*Bakelite (170-250 ft./min.)----	10,000	8,000	6,000	4,000	3,000	2,200	1,800	1,500	1,300
**Engraver's brass and aluminum (375-425 ft./min.)	10,000 to 15,000	10,000 to 15,000	10,000 to 15,000	8,000	6,000	5,000	4,000	3,500	3,000
Cast iron (130-250 ft./min.)----	8,000	7,500	5,500	3,500	2,500	2,000	1,650	1,400	1,200
Hard bronze and machine steel (80-200 ft./min.)	7,000	6,000	3,000	2,200	1,600	1,200	975	800	700
Annealed tool steel (70-100 ft./ min.)	5,000	4,500	2,300	1,600	1,200	1,000	850	725	600
Stainless steel, Monel (45-75 ft./min.)	3,500	2,750	1,400	1,050	700	575	500	435	350
Very hard die and alloy steels (30-45 ft./min.)	2,000	1,250	800	600	475	400	350	300	250

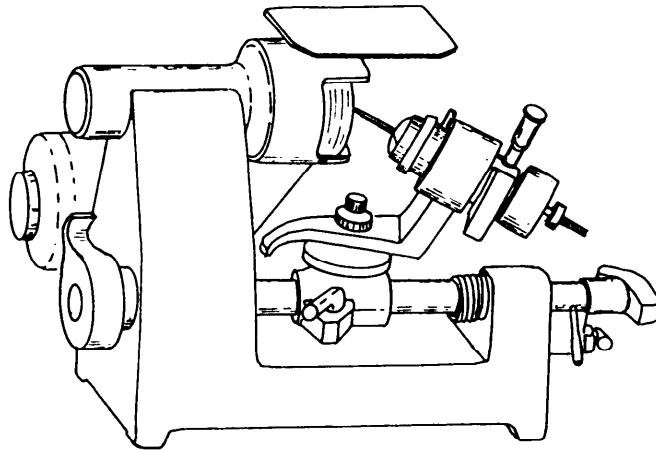


Figure 9-20.—Cutter grinder.

## CUTTER SPEEDS

The speeds listed in table 9-2 represent typical speeds for given materials when you are using a high-speed steel cutter. If you are using a carbide cutter, refer to your operators manual for the correct speeds. When using table 9-2, keep in mind that the speeds recommended will vary greatly with the depth of cut, and particularly with the rate at which you feed the cutter through the work.

Run the cutters at the highest speeds possible without burning them, and remove stock with several light, fast cuts rather than one heavy, slow cut. When you cut steel and other hard materials, start with a slow speed and work up to the fastest speed the cutter will stand without losing its cutting edge. Sometimes you may have to sacrifice cutter life to obtain the smoother

finish possible at higher speeds. With experience you will know when the cutter is running at its maximum efficiency.

## GRINDING CUTTERS

Improper grinding of cutters causes most of the problems in using very small cutters on small lettering. The cutter point must be accurately sharpened. Problems usually occur because the point is burned, the flat is either too high or too low, or perhaps the clearance does not run all the way to the point. Stone off the flat with a small, fine oilstone to make the cutting edge keener.

The cutter grinder shown in figure 9-20 is equipped with interchangeable grinding wheels for carbide and high-speed steel cutters. We will discuss grinding-high

Deleted—No permission granted for electronic copy.

Figure 9-21.—Position of diamond for truing a grinding wheel.

Deleted—No permission granted for electronic copy.

Figure 9-22.—Grinding a conical point. A. Cutter angle. B. Rough and finished conical shape.

speed cutters. Refer to your machine manufacturer's manual for information on the operation of your grinder and the angles for carbide cutters.

### Grinding Single-Flute Cutters

Before you begin grinding, true up the grinding wheel with the diamond tool supplied with the grinder. Insert the diamond and set the toolhead at approximately the same relation to the wheel, as shown in figure 9-21. Then, swing the diamond across the face of the wheel by rocking the toolhead in much the same manner as you do when grinding a cutter. Your maximum cut should be 0.001 to 0.002 inch. If the diamond fails to cut freely, turn it slightly in the toolhead to present an unused portion of the diamond to the wheel.

**ROUGH AND FINISH GRINDING A CONICAL POINT.**—Set the grinder toolhead to the desired cutting edge angle (fig. 9-22, view A). This angle usually varies from 30° to 45° depending on the work desired. Use a 30° angle for most sunken letter or design engraving on metal or bakelite plates. Now place the cutter in the toolhead and rough grind it to approximate size by swinging it across the wheel's face. Do not rotate the cutter while it is in contact with the face of the wheel, but swing it straight across, turning it slightly **BEFORE** or **AFTER** it makes contact with the wheel. This will produce a series of flats, as in the rough shape shown in figure 9-22, view B. Now feed the cutter

Deleted—No permission granted for electronic copy.

Figure 9-23.—Grinding the flat. A. Flat not ground to center. B. Flat ground to center.

Deleted—No permission granted for electronic copy.

Figure 9-24.—First operation in grinding clearance.

Deleted—No permission granted for electronic copy.

Figure 9-25.—A tipped off cutter.

into the wheel and rotate it at the same time to grind off the flats and produce a smooth cone. The finished cone should look like the finished conical shape in figure 9-22, view B, smooth and entirely free of wheel marks.

**GRINDING THE FLAT TO CENTER.**—The next operation is to grind the flat to center. For very small, delicate work it is absolutely essential to grind this flat **EXACTLY** to center. If the flat is oversize, you

Table 9-3.—Rake Angles for Single-Flute Cutters

Material to be cut	Angle B (See figs. 12-27) and 12-28)
Tool steel -----	5-10 degrees
Machine steel-----	10-15 degrees
Hard brass -----	15-20 degrees
Aluminum -----	20-25 degrees
Bakelite, celluloid, wood, fiber -----	20-25 degrees

can readily see it after grinding the cone, and the point will appear as shown in figure 9-23, view A and the left side of view B. To correct this, grind the flat to center as in the right side of view B.

**GRINDING THE CHIP CLEARANCE.**—The cutter now has the correct angle and a cutting edge, but has no chip clearance. This must be provided to keep the back side of the cutter from rubbing against the work and heating excessively, and to allow the hot chips to fly off readily. The amount of clearance varies with the angle of the cutter. Use the following procedure to grind chip clearance:

In the first step, gently feed the cutter into the face of the wheel. Do not rotate the cutter. Hold the back (round side) of the conical point against the wheel. Rock the cutter continuously across the wheel's face, without turning it, until you grind a flat that runs out exactly at the cutter point (fig. 9-24). Check this very carefully, with a magnifying glass if necessary, to be sure you have reached the point with this flat. Be extremely careful not to go beyond the point.

In the next step, grind away the rest of the stock on the back of the conical side to the angle of the flat, up to the cutting edge. Rotate the conical side against the face of the wheel and remove the stock, as shown in figure 9-22, view B. Be extremely careful not to turn the cutter too far and grind away part of the cutting edge. Clean up all chatter marks. Be careful of the point; this is where the cutting is done. If this point is incorrectly ground, the cutter will not work.

**TIPPING OFF THE CUTTER POINT.**—To engrave hairline letters up to 0.0005 inch in depth, you should not flatten, or **TIP OFF**, the cutter point. For ordinary work, however, you should flatten this point as much as the work will permit. Otherwise, it is very difficult to retain a keen edge with such a fine point, and when the point wears down, the cutter will immediately fail to cut cleanly. The usual way to tip off is to hold the

cutter in your hands at the proper inclination from the grinding wheel face and touch the cutter very lightly against the wheel. You also may dress it with an oilstone. Angle A (fig. 9-25) should be approximately 3°; this angle causes the cutter to bite into the work like a drill when it is fed down. Angle B (fig. 9-25) varies, depending on the material to be engraved. Use table 9-3 as a guide to determine angle B.

**Grinding Square-Nose Single-Flute Cutters**

A properly ground square-nose single-flute cutter should be similar to the one shown in figure 9-26. When square-nose cutters are ground, they should be tipped off in the same manner as described in connection with figure 9-25. All square-nose cutters have their peripheral clearances ground back of the cutting edge. After grinding the flat to center (easily checked with a micrometer), grind the clearance by feeding the cutter in the required amount toward the wheel and turning the cutter until you have removed all stock from the back

Deleted—No permission granted for electronic copy.

Figure 9-26.—Square-nose cutter with a properly ground tip.

Table 9-4.—Chip Clearance Table for Square-Nose Cutters

Cutter diameter	Clearance	Cutter diameter	Clearance
Inches	Inches	Inches	Inches
1/10	.004	1/4	.010
1/8	.006	5/16	.012
5/32	.006	3/8	.015
3/16	.008	7/16	.015
		1/2	.020

Table 9-5.—Clearance Angles for Three- and Four-Sided Cutters

Degrees of cutting . . . . .	45°	40°	35°	30°	25°	20°	15°	10°	5°
Angle of clearance:(Degrees)									
3 sides . . . . .	26 1/2	23	19 1/2	16	13	10 1/2	7 1/2	5	2 1/2
4 sides . . . . .	35 1/2	23	25 1/2	22 1/2	18 1/2	14 1/2	10	7	3 1/2

(round side), up to the cutting edge. Table 9-4 provides information on chip clearance for various sized cutters.

**Grinding Three- and Four-Sided Cutters**

Three- and four-sided cutters (see fig. 9-27) are used to cut small steel stamps and to engrave small engraving where a very smooth finish is desired. The index plate on the toolhead collet spindle has numbered index holes for indexing to grind three- and four-sided cutters, as explained in the next paragraph.

Set the toolhead for the desired angle. Plug the pin in the index hole for the desired number of divisions and grind the flats. Now, without loosening the cutter in the toolhead collet, reset the toolhead to the proper clearance angle. Clearance angles are listed in table 9-5.

**PANTOGRAPH ATTACHMENTS**

Some attachments commonly used with the pantograph are copy dial holders, indexing attachments,

forming guides, and rotary tables. These attachments extend the capabilities of the pantograph from flat, straight line engraving to include circular work, cylindrical work, and indexing.

When you use a circular copy plate, you may use the copy dial holder, shown in figure 9-28, instead of the regular copyholder. This holder has a spring-loaded indexing pawl, which is aligned with the center pivot hole. This pawl engages in the notches in a circular copy plate to hold the plate in the position required to engrave the character.

You may use an indexing attachment, such as that shown in figure 9-29, to hold cylindrical work to be graduated. In some cases, the dividing head (used on the milling machine) is used for this purpose. The work to

Deleted—No permission granted for electronic copy.

Figure 9-27.—Three-sided cutter.

Deleted—No permission granted for electronic copy.

Figure 9-28.—Copy dial holder and plate.

Deleted—No permission  
granted for electronic copy.

**Figure 9-29.—Using an indexing attachment.**

be engraved is held in this attachment and may be indexed for any number of divisions available on the plate. Figure 9-29 shows a micrometer collar being held for graduation and engraving.

You will use a forming guide (sometimes called a radius plate) to engrave cylindrical surfaces. The contour of the guide must be the exact opposite of the work; if the work is concave the guide must be convex and vice versa. Mount the forming guide on the forming bar. (See fig. 9-29.) When the spindle floating mechanism is released, the spindle follows the contour of the forming guide.

Use the rotary table shown in figure 9-30 to hold work such as face dials. It is similar to the rotary table used on milling machines. It is mounted directly on the

Deleted—No permission  
granted for electronic copy.

**Figure 9-30.—A rotary table.**

worktable and provides a means of rapid graduation and of engraving the faces of disks.

## USING A CIRCULAR COPY PLATE

You should be able to use a circular copy plate efficiently to engrave several similar workpieces with single characters used consecutively. For example, you can use the following setup to engrave 26 similar workpieces with a single letter, but with each piece having a different letter.

1. Set the workpiece conveniently on the worktable and clamp two aligning stops in place. Do not remove these stops until the entire job is completed.

2. Set the circular plate on the copyholder so that the plate can be rotated by hand. Check to ensure that the indexing pawl engages the notch on the rim so the plate will be steady while you trace each character.

3. Set the machine for the required reduction and speed, and adjust the worktable so the spindle is in position over the workpiece.

4. Clamp the first workpiece in place on the worktable. (The aligning stops, step 1, ensure accurate positioning.)

5. Rotate the circular plate until the letter A is under the tracing stylus and the index pawl is engaged in the notch.

6. Engrave the first piece with the letter A. Check the operation for required adjustments of the machine.

7. After you have finished the first piece, remove it from the machine. Do not change the alignment of the aligning stops (step 1), the worktable, or the copyholder. Place the second workpiece in the machine. Index the circular plate to the next letter and repeat the process.

8. Continue to load the workpieces, index the plate to the next character, engrave, and remove the work until you have finished the job.

## ENGRAVING A GRADUATED COLLAR

To engrave a graduated collar, as shown in figure 9-29, use a forming guide and indexing attachment. You also can use the circular copy plate to speed up the numbering process. After you engrave each graduation, index the work to the next division until you finish the graduating. When you engrave numbers with more than one digit, offset the work angularly by rotating the work

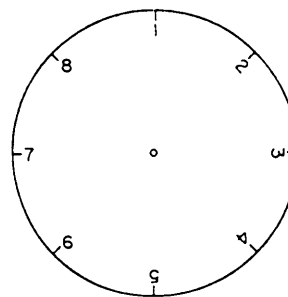


Figure 9-31.—A dial face.

so the numbers are centered on the required graduation marks.

## ENGRAVING A DIAL FACE

Use a rotary table and a circular copy plate to engrave a dial face, such as the one shown in figure 9-31. Note that the figures on the right side of the dial are oriented differently from those on the left side; this illustrates the usual method of positioning characters on dials. The graduations are radially extended from the center of the face. The graduations also divide the dial into eight equal divisions.

Use the following procedures to set up and engrave a dial face:

1. Set the reduction required. Use the size of the copy on the circular copy plate and the desired size of the numerals on the work as the basis to compute the reduction.

2. Set the copy plate on the copyholder and be sure it is free to rotate when the ratchet is disengaged.

3. Mount a rotary table on the worktable of the engraver. Position the dial blank on the rotary table so the center of the dial coincides with the center of the rotary table. Clamp the dial blank to the rotary table.

4. Place the tracing stylus in the center of the circular copy plate and adjust the worktable so the center of the dial is directly under the point of the cutter.

5. Rotate the copy plate until the copy character used to make graduation marks is aligned with the center of the copy plate and the center of the work. Set the stylus in this mark. Now, by feeding the worktable straight in toward the back of the engraver, adjust the table so the cutter will cut the graduation to the desired length.

6. Start the machine and adjust the engraver worktable vertically for the proper depth of cut. Then, clamp the table to prevent misalignment of the work.

Any further movement of the work will be made by the rotary table feed mechanism.

7. Engrave the first graduation mark.

8. Using the rotary table feed wheel, rotate the dial to the proper position for the next graduation. Since there are eight graduations, rotate the table  $45^\circ$ ; engrave this mark and continue until the circle is graduated. You will now be back to the starting point.

**NOTE:** Do not move the circular copy plate during the graduating process.

9. To engrave numbers positioned as shown on the right side of the dial in figure 9-31, move the worktable so the cutter is in position to engrave the numbers. Rotate the circular copy plate to the numeral 1 and engrave it. Rotate the rotary table  $45^\circ$  and the circular

copy plate to 2, and engrave it. Continue this process until you have engraved all the numbers. If two- (or more) digit numbers are required, offset the dial as previously described.

10. To engrave the numbers shown on the left side of the dial in figure 9-31, rotate the copy plate to the required number. Then, using the cross feed and longitudinal feed of the engraver table, position the cutter over the work at the point where the number is required. This method requires you to reposition the worktable for each number. As previously stated, movement of the engraver worktable in two directions results in angular misalignment of the character with the radius of the face; in this example, angular misalignment is required.





## CHAPTER 10

# PRECISION GRINDING MACHINES

### CHAPTER LEARNING OBJECTIVES

*Upon completing this chapter, you should be able to do the following:*

- *Describe speeds, feeds, and coolants used while grinding.*
- *Describe and explain the use of surface grinders.*
- *Describe and explain the use of cylindrical grinders.*
- *Describe and explain the use of tool and cutter grinders.*

Modern grinding machines are versatile and are used to perform work of extreme accuracy. They are used primarily to finish surfaces that have been machined in other machine tool operations. Surface grinders, cylindrical grinders, and tool and cutter grinders can perform practically all of the grinding operations required in Navy repair work.

To perform these operations, you must know the construction and principles of operation of commonly used grinding machines. You gain proficiency in grinding through practical experience. Therefore, you should take every opportunity to watch or perform grinding operations from setup to completion.

There are several classes of each type of grinder. The **SURFACE** grinder may have either a rotary or a reciprocating table and either a horizontal or a vertical spindle. **CYLINDRICAL** grinders may be classified as plain, centerless, or internal grinders; the **TOOL AND CUTTER** grinder is basically a cylindrical grinder. Those generally found in Navy machine shops are the reciprocating table grinder, the horizontal spindle (planer type) surface grinder, the plain cylindrical grinder, and the tool and cutter grinder. Shops also may have a universal grinder, which is similar to a tool and cutter grinder except that it is designed for heavier work and usually has a power feed system and a coolant system.

Before operating a grinding machine, you must understand the underlying principles of grinding and the purpose and operation of the various controls and parts of the machine. You also must know how to set

up the work in the machine. The setup procedures will vary with the different models and types of machines. Study the manufacturer's technical manual to learn specific procedures for a particular model of machine.

As with any shop equipment you must observe all posted safety precautions. Review your equipment operators manual for safety precautions and any chapters of *Navy Occupational Safety and Health (NAVOSH) Program Manual for Forces Afloat*, OPNAV Instruction 5100.19B, that apply to the equipment.

### GRAIN DEPTH OF CUT

On most ships, stowage space is limited. Consequently, the inventory of grinding wheels must be kept to a minimum. It would be impractical and unnecessary to keep on hand a wheel for every grinding job. With a knowledge of the theory of grain depth of cut you can vary the cutting action of the various wheels and with a small inventory can perform practically any grinding operation that may be necessary.

For ease in understanding this theory, assume that a grinding wheel has a single grain. When the grain reaches the point of contact with the work, the depth of cut is zero. As the wheel and the work revolve, the grain begins cutting into the work, increasing its depth of cut until it reaches a maximum depth at some point along the arc of contact. This greatest depth is called the grain depth of cut.

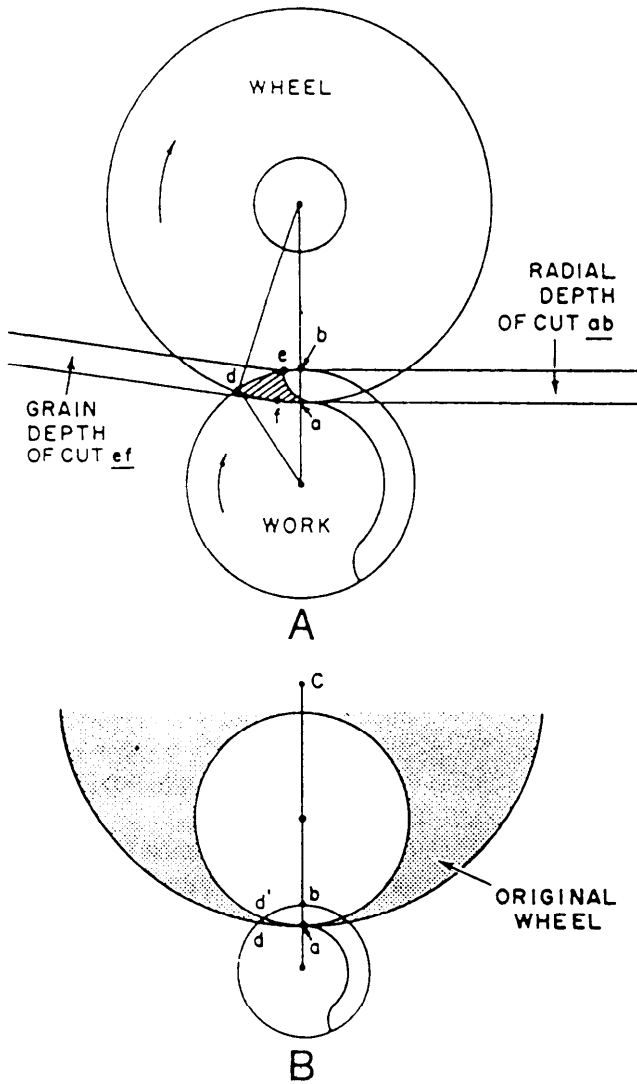


Figure 10-1.—Grain depth of cut; center-type machine.

To understand what part grain depth of cut plays in grinding, look at figure 10-1. View **A** illustrates a grinding wheel and a workpiece;  $ab$  is the radial depth of cut,  $ad$  is the arc of contact, and  $ef$  is the grain depth of cut. As the wheel rotates, the grain moves from the point of contact  $a$  to  $d$  in a given amount of time. During the same time, a point on the workpiece rotates from  $d$  to  $e$ , at a slower speed than that of the wheel. During this time the grain will remove an amount of material represented by the shaded area  $ade$ . Now refer to view **B** and assume that the wheel has worn down to a much smaller size, while the wheel and work speeds remain unchanged. The arc of contact  $ad'$  of the smaller wheel is shorter than the arc of contact  $ad$  of the original (larger) wheel. Since the width of the grains remains the same, decreasing the length of the arc of contact will decrease the surface (area = length  $\times$  width) that a grain on the smaller wheel covers in the same time as a grain

on the larger wheel. If the depth that each grain cuts into the workpiece remains the same, the grain on the smaller wheel will remove a smaller volume (volume = length  $\times$  width  $\times$  depth) of material in the same time as the grain on the larger wheel. However, for both grains to provide the same cutting action, they both have to remove the same volume of material in the same length of time. To make the volume of material the grain on the smaller wheel removes equal to that of the grain on the larger wheel, you have to either make the grain on the smaller wheel cut deeper into the workpiece or cover a larger workpiece surface area at its original depth of cut.

To make the grain cut deeper, you must increase the feed pressure on the grain. This increase of feed pressure will cause the grain to be torn from the wheel sooner, making the wheel act like a softer wheel. Thus, the grain depth of cut theory says that as a grinding wheel gets smaller, it will cut like a softer wheel because of the increase in feed pressure required to maintain its cutting action.

The opposite is true if the wheel diameter increases. For example, if you replace a wheel that is too small with a larger wheel, you must decrease feed pressure to maintain the same cutting action.

The other previously mentioned way to make a grain on a smaller wheel remove the same amount of material as a grain on a larger wheel is to keep the depth of cut the same (no increase in feed pressure) while you increase the surface area the grain contacts. Increasing the surface area requires lengthening the contact area, since the width remains the same. To lengthen the contact area, you can either speed up the workpiece rotation or slow down the wheel rotation. Either of these actions will cause a longer surface strip of the workpiece to come in contact with the grain on the wheel, thereby increasing the volume of material removed.

As mentioned earlier, the opposite is true if you increase the wheel diameter. To keep from removing a larger volume of material, you must decrease the surface of the workpiece with which the grain comes into contact. You can do this by either slowing down the workpiece rotation or speeding up the wheel rotation.

Keep in mind that all of these actions are based on the grain depth of cut theory. That is, making adjustments to the grinding procedure to make one wheel cut like another. The following summary shows the actions you can take to make a wheel act a certain way:

### MAKE THE WHEEL ACT SOFTER (INCREASE THE GRAIN DEPTH OF CUT)

Increase the work speed.

Decrease the wheel speed.

Reduce the diameter of the wheel and increase feed pressure.

### MAKE THE WHEEL ACT HARDER (DECREASE THE GRAIN DEPTH OF CUT)

Decrease the work speed.

Increase the wheel speed.

Increase the diameter of the wheel and decrease feed pressure.

### SPEEDS, FEEDS, AND COOLANTS

As with other machine tools, the selection of the proper speed, feed, and depth of cut is an important factor in grinding. Also, coolants may be necessary for some operations. The definitions of the terms *speed*, *feed*, and *depth of cut*, as applied to grinding, are basically the same as those in other machining operations.

**WHEEL SPEED**, unless otherwise defined, means the surface speed of the grinding wheel in fpm. **TRAVERSE** (longitudinal or cross) is the rate that the work is moved across the working face of the grinding wheel. **FEED** is the depth of cut the wheel takes in each pass across the work. We'll explain each of these in the next paragraphs

### WHEEL SPEED

Grinding wheel speeds commonly used in precision grinding vary from 5,500 to 9,500 fpm. You can change wheel speed by changing the spindle speed or by using a larger or smaller wheel. To find the wheel speed in fpm, multiply the spindle speed (rpm) by the wheel circumference (inches) and divide the product by 12.

$$fpm = \frac{(cir. \times rpm)}{12}$$

$$fpm = \frac{\pi \times D \times rpm}{12}$$

The maximum speed listed on a grinding wheel is not necessarily the speed at which it will cut best. The manufacturer decides the maximum speed based on the strength of the wheel. That speed provides a margin of safety and the wheel usually will cut better at a lower speed.

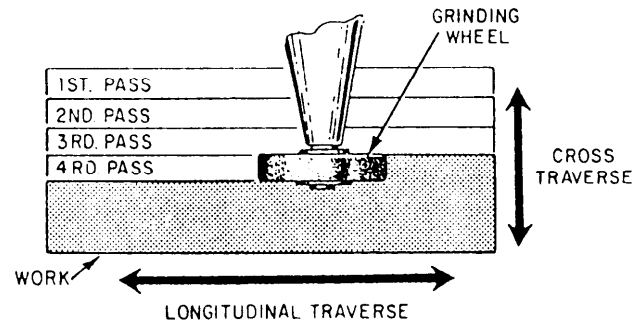


Figure 10-2.—Surface grinding a flat workpiece.

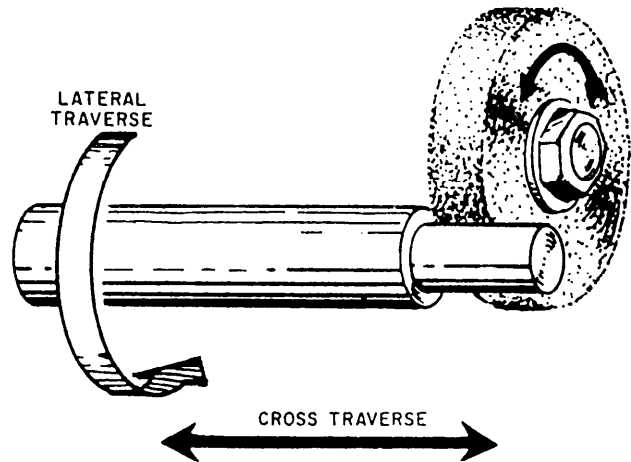


Figure 10-3.—Surface grinding a cylindrical workpiece.

One method used to determine the proper wheel speed is to set the speed between the minimum and maximum recommended by the manufacturer. Take a trial cut. If the wheel acts too soft, increase the speed. If it acts too hard, decrease the speed.

### TRAVERSE (WORK SPEED)

During the surface grinding process, the work moves in two directions. As a flat workpiece is being ground (fig. 10-2), it moves under the grinding wheel from left to right (longitudinal traverse). This longitudinal speed is called work speed. The work also moves gradually from front to rear (cross traverse), but this movement occurs at the end of each stroke and does not affect the work speed. We'll explain how to set cross traverse later in this chapter.

You should grind a cylindrical workpiece in a manner similar to the finishing process used on a lathe (fig. 10-3). As the surface of the cylinder rotates under the grinding wheel (lateral traverse), the work moves from left to right (cross traverse).

To select the proper work speed, take a cut with the work speed set at 50 fpm. If the wheel acts too soft, decrease the work speed. If the wheel acts too hard, increase the work speed.

Wheel speed and work speed are closely related. Usually, you can adjust one or both to get the most suitable combination.

## DEPTH OF CUT

The depth of cut depends on such factors as the material from which the work is made, heat treatment, wheel and work speed, and condition of the machine. Roughing cuts should be as heavy as the machine can take; finishing cuts are usually 0.0005 inch or less. For rough grinding, you might use a 0.003-inch depth of cut as a trial. Then, adjust the machine until you get the best cutting action.

## COOLANTS

The cutting fluids used in grinding operations are the same as those used in other machine tool operations. Synthetic coolants are the best, but you also may use a mixture of soluble oil and water. As in most machining operations, the coolant helps to maintain a uniform temperature between the tool and the work to prevent extreme localized heating. Excessive heat will damage the edges of cutters, cause warpage, and may cause inaccurate measurements.

In other machine tool operations, the chips will fall aside and present no great problem; this is not true in grinding work. If you have no way to remove chips, they can become embedded in the face of the wheel. This embedding, or loading, will cause unsatisfactory grinding and you will need to dress the wheel frequently. A sufficient volume of cutting fluid will help prevent loading. The fluid also helps to reduce friction between the wheel and the work and to produce a good finish. When you select a cutting fluid for a grinding operation, it should have the following characteristics:

- Have a high cooling capacity to reduce cutting temperature
- Prevent chips from sticking to the work
- Be suitable for a variety of machine operations on different materials, reducing the number of cutting fluids needed in the shop
- Have long life and not emit obnoxious odors or vapors harmful to personnel

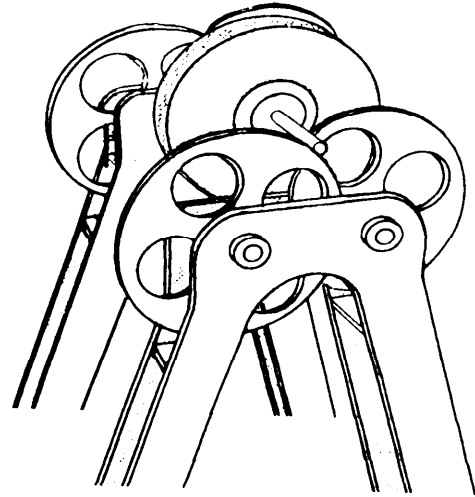


Figure 10-4.—Overlapping disk balancing ways (roller type).

- Not cause rust or corrosion
- Have a low viscosity to permit gravity separation of impurities and chips as it is circulated in the cooling system
- Not oxidize or form gummy deposits that will clog the circulating system
- Be transparent, allowing a clear view of the work
- Be safe, particularly in regard to fire and accident hazards
- Not cause skin irritation

The principles discussed above are basic to precision grinding machines. Keep them in mind as you study about the machines in the remainder of this chapter.

## WHEEL BALANCING

You may need to balance wheels larger than 14 inches, but usually not smaller ones. A wheel that is slightly out of balance may cause chatter marks in the workpiece finish. One that is drastically out of balance may damage the grinder or fly apart and injure the operator.

You should balance grinding wheels on either the overlapping disk balancing ways (roller type) (fig. 10-4) or on parallel ways (knife edge) (fig. 10-5). Set these stands as level as possible, mount the wheel on a balancing arbor, and place it on the rollers or ways. The heavy side will rotate to the lowest position. Adjust

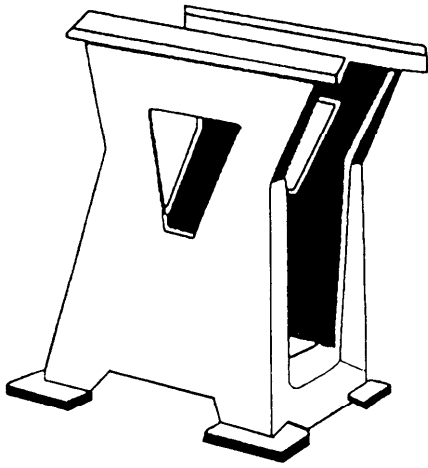


Figure 10-5.—Parallel ways (knife edge).

Deleted—No permission granted for electronic copy.

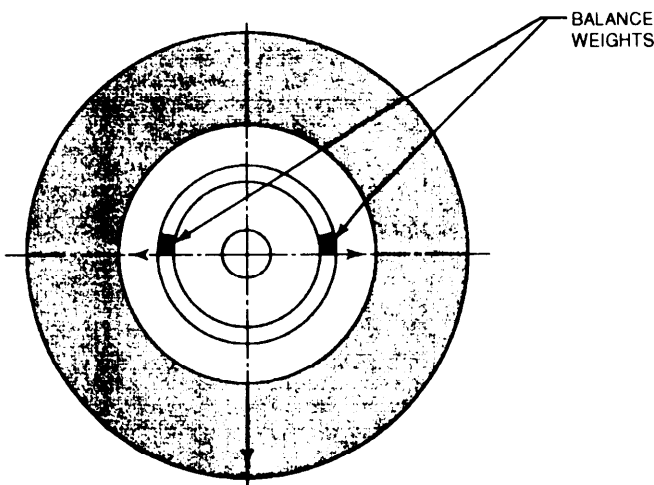


Figure 10-6.—Balance weights.

Figure 10-7.—Surface grinder (planer type).

weights in the flanges (fig. 10-6) to get the correct balance.

sliding tables. This smooth, direct power is very advantageous in grinding. The piping from this unit is usually connected to power cylinders under the traverse table. When the machine is operating automatically, control valves divert pressurized hydraulic fluid to the proper cylinder, causing the table to move in the desired direction. Suitable bypass and control valves in the hydraulic system let you stop the traverse table in any position and regulate the speed of movement of the table within limits. These valves provide a constant pressure in the hydraulic system, allowing you to stop the feed without securing the system.

### SURFACE GRINDER

Most of the features shown in figure 10-7 are common to all planer-type surface grinders. The basic components of this machine are a base, a cross traverse table, a sliding worktable, and a wheelhead. Various controls and handwheels control the movement of the machine during the grinding operation.

### CROSS TRAVERSE TABLE

The cross traverse table is mounted on ways that are parallel to the spindle of the wheelhead unit. This allows the entire width of the workpiece to be traversed under the grinding wheel.

The base is a heavy casting that houses the wheelhead motor, the hydraulic power feed unit, and the coolant system. Use the ways on top of the base to mount the cross traverse table. Use the vertical ways on the back of the base to mount the wheelhead unit.

A piston in a power cylinder is fastened to the cross traverse table to provide power feed. A handwheel attached to a feed screw provides manual feed. The thickness (width) of the grinding wheel determines the amount of cross traverse feed per stroke of the reciprocating sliding table. During roughing cuts, the work should traverse slightly less than the thickness of the wheel each time it passes under the wheel. For finish cuts, decrease the rate until you obtain the desired finish. When you engage the power feed mechanism, the cross traverse table feeds only at each end of the stroke of the

The hydraulic power unit includes a motor, a pump, and piping. These provide hydraulic pressure to the power feed mechanisms on the cross traverse and

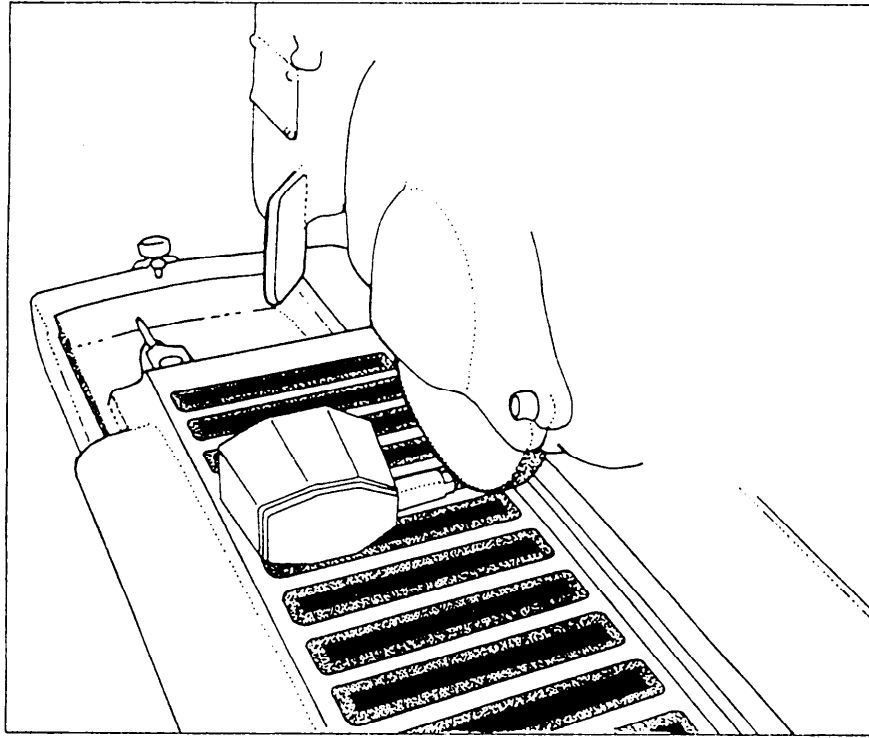


Figure 10-8.—Magnetic chuck used for holding a tool grinding fixture.

sliding table (discussed in the next paragraphs). The grinding wheel clears the ends of the workpiece before cross-feed is made; this decreases side thrust on the grinding wheel and prevents a poor surface finish on the ends of the workpiece.

Grinding machines in shipboard shops usually have 12 inches or less of cross traverse. It isn't necessary to traverse the full limit for each job. To limit the cross traverse to the width of the work being ground, use the adjustable cross traverse stop dogs that actuate the power cross traverse control valves.

### SLIDING TABLE

The sliding table is mounted on ways on the top of the cross traverse table. Recall that the sliding table moves from left to right, carrying the workpiece under the grinding wheel.

The top of the sliding table has T-slots machined in it so you can clamp work or workholding devices like magnetic chucks or vises onto the table. You can traverse the sliding table manually or by power.

The power feed of the table is similar to that of the cross traverse table. During manual traverse, a pinion turned by a handwheel engages a rack attached to the bottom of the sliding table.

During manual operation of the sliding table, table stop dogs limit the length of stroke. When power feed

is used, table reverse dogs reverse the direction of movement of the table at each end of the stroke. The reverse dogs actuate the control valve to shift the hydraulic feed pressure from one end of the power cylinder to the other.

You can usually adjust the speed (fpm) of the sliding table within a wide range to give the most suitable speed.

### WHEELHEAD

The wheelhead carries the motor-driven grinding wheel spindle. You can adjust the wheelhead vertically to feed the grinding wheel into the work by turning a lead screw type of mechanism similar to that used on the cross traverse table. A graduated collar on the handwheel lets you keep track of the depth of cut.

The wheelhead movement is not usually power fed because the depth of cut is quite small and you need large movement only to set up the machine. The adjusting mechanism is quite sensitive; you can adjust the depth of cut in amounts as small as 0.0001 inch.

### WORKHOLDING DEVICES

In most surface grinding operations, you will use one of two workholding devices, either a magnetic

chuck or a universal vise. We will discuss each of them in the next paragraphs.

## Magnetic Chucks

Since most surface grinding is done on flat workpieces, most surface grinders have magnetic chucks. These chucks are simple to use. You can mount the work directly on the chuck or on angle plates, parallels, or other devices mounted on the chuck. You cannot hold nonmagnetic materials in a chuck unless you use special setups.

The top of a magnetic chuck (see fig. 10-8) is a series of magnetic poles separated by nonmagnetic materials. The magnetism of the chuck may be induced by permanent magnets or by electricity. In a permanent-type magnetic chuck, the chuck control lever positions a series of small magnets inside the chuck to hold the work. In an electromagnetic chuck, electric current induces magnetism in the chuck; the control lever is an electric switch. For either chuck, work will not remain in place unless it contacts at least two poles of the chuck.

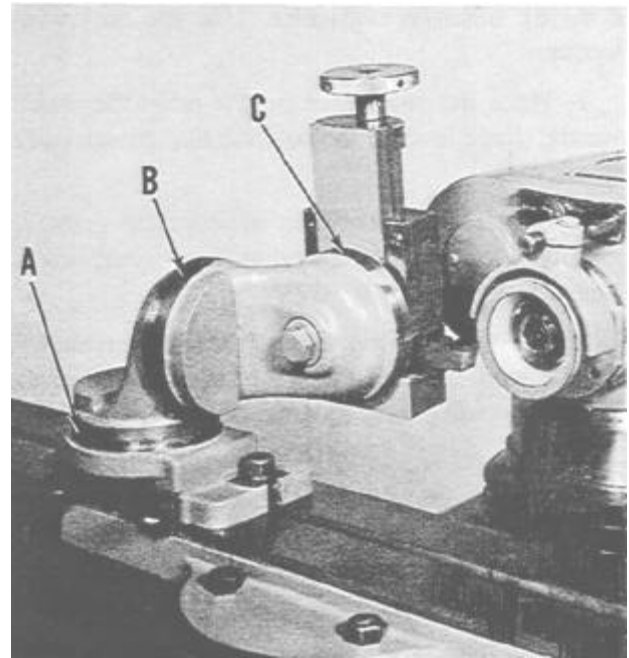
Work held in a magnetic chuck may become magnetized during the grinding operation. This is not usually desirable and the work should be demagnetized. Most modern magnetic chucks are equipped with demagnetizers.

A magnetic chuck will become worn and scratched after repeated use and will not produce the accurate results normally required of a grinder. You can remove small burrs by hand stoning with a fine grade oilstone. But, you must regrind the chuck to remove deep scratches and low spots caused by wear. If you remove the chuck from the grinder, be sure to regrind the chuck table when you replace the chuck to make sure the table is parallel with the grinder table. To grind the table, use a soft grade wheel with a grit size of about 46. Feed the chuck slowly with a depth of cut that does not exceed 0.002 inch. Use enough coolant to help reduce heat and flush away the grinding chips.

## Universal Vise

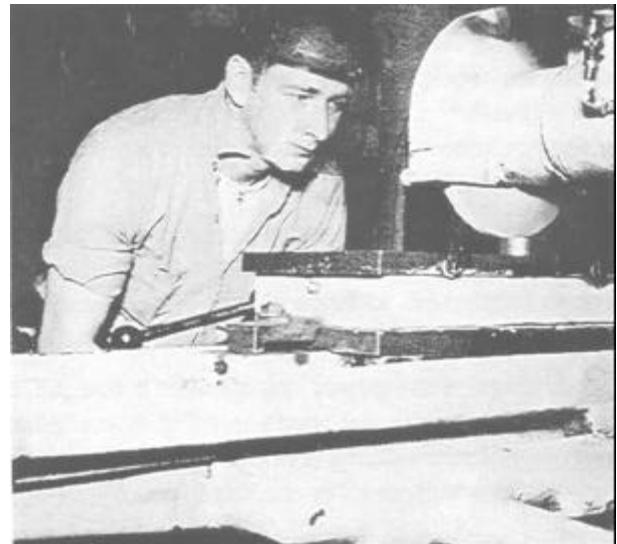
You will usually use the universal vise (fig. 10-9) when you need to grind complex angles on a workpiece. You can mount the vise directly on the worktable of the grinder or on the magnetic chuck.

You can use the universal vise to set up work, such as lathe tools, so you can position the surface to be ground at any angle. The swivels rotate through 360°. You can rotate the base swivel (A, fig. 10-9) in a horizontal plane; the intermediate swivel (B, fig. 10-9)



28.251

Figure 10-9.—Universal vise (mounted on a tool and cutter grinder). A. Base swivel. B. Intermediate swivel. C. Vise swivel.



28.256

Figure 10-10.—Grinding a spacer on a surface grinder.

in a vertical plane; and the vise swivel (C, fig. 10-9) in either a vertical or a horizontal plane, depending on the position of the intermediate swivel.

## SURFACE GRINDER OPERATION

We will use a hardened steel spacer similar to the one shown in figure 10-10 as an example of work you

can do on a surface grinder. Use the following procedures:

1. Place the workpiece on the magnetic chuck. Move the chuck lever to the position that energizes the magnetic field.
2. Select and mount an appropriate grinding wheel. This job requires a straight-type wheel with a designation similar to A60F12V.
3. Set the table stop dogs so the sliding table will move the work clear of the wheel at each end of the stroke. If you use power traverse, set the table reverse dogs.
4. Set the longitudinal traverse speed of the worktable. To rough grind hardened steel, use a speed of about 25 fpm; to finish the piece, use 40 fpm.
5. Set the cross traverse mechanism so the table moves under the wheel a distance slightly less than the width of the wheel after each pass. (Refer to the manufacturer's technical manual for specific procedures for steps 4 and 5.)
6. Start the spindle motor, let the machine run for a few minutes, and then dress the wheel.
7. Feed the moving wheel down until it just touches the work surface; then use the manual cross traverse handwheel to move the work clear of the wheel. Set the graduated feed collar on zero to keep track of how much you feed the wheel into the work.
8. Feed the wheel down about 0.002 inch and engage the longitudinal power traverse. Use the cross traverse handwheel to bring the grinding wheel into contact with the edge of the workpiece.
9. Engage the power cross traverse and let the wheel grind across the surface of the workpiece. Carefully note the cutting action to decide if you need to adjust the wheel speed or the work speed.
10. Stop the longitudinal and cross traverses and check the workpiece.

Figure 10-9 shows a universal vise being used on a tool and cutter grinder to grind a lathe tool bit. For this job, set the base swivel (A) to the required side cutting edge angle, the intermediate swivel (B) to the side clearance angle, and the vise swivel (C) so the vise jaws are parallel to the table. Then, use a cup-type wheel to grind the side of the tool. Reset the universal vise to cut the end and top of the tool after the side is ground.

You can use the universal vise on a surface grinder for very accurate grinding of lathe cutting tools such as

threading tools. For example, to grind an Acme threading tool, set the vise swivel at  $14\ 1/2^\circ$  from parallel to the table. Set the intermediate swivel to the clearance angle. Set the base swivel so the tool blank (held in the vise jaws) is parallel to the spindle of the grinder. Remember to leave the tool blank extending far enough out of the end of the vise jaws to prevent the grinding wheel from hitting the vise. After grinding one side of the tool bit, turn it one-half turn in the vise and set the intermediate swivel to an equal but opposite angle to the angle set for the first side. This setting will result in a clearance equal to the clearance of the first side.

Another method for grinding single-point tools is to hold the tool in a special fixture, as shown in figure 10-8. The fixture surfaces are cut at the angles necessary to hold the tool so the angles of the tool bit are formed properly.

When you use either method to grind tool bits, check the bit occasionally with an appropriate gauge until you have the correct dimensions. To save time, rough grind the bit to approximate size on a bench grinder before you set it in the jig.

## CYLINDRICAL GRINDER

The cylindrical grinder is used to grind work such as round shafts. Although many of the construction features of the cylindrical grinder are similar to those of the surface grinder, there is a considerable difference in the functions of the components. Cylindrical grinders have no cross traverse table. An additional piece of equipment (the workhead) is mounted on the sliding table, and the wheelhead spindle is parallel to the sliding table. See figure 10-11.

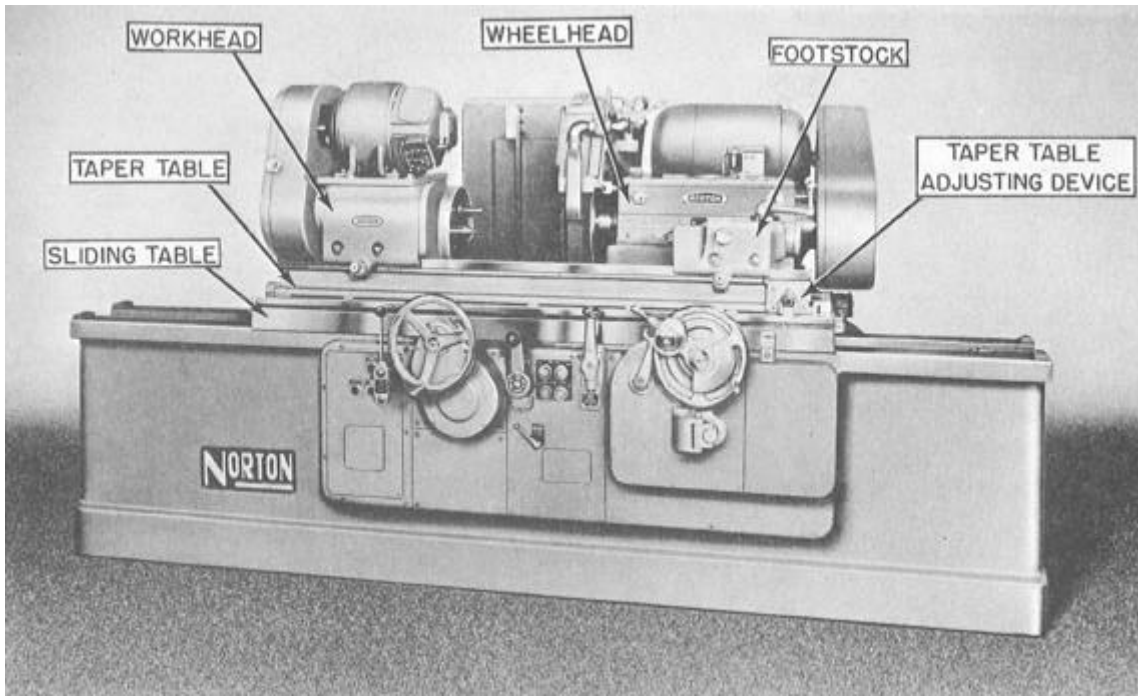
As in the surface grinder, the base of this machine contains a hydraulic power unit and a coolant system. Longitudinal ways support the sliding table. Horizontal ways (at right angles to the longitudinal ways) permit the wheelhead to move toward or away from the workpiece. You will use this horizontal movement to feed the grinding wheel into the work for a depth of cut.

## SLIDING TABLE

The sliding table of the cylindrical grinder is mounted directly on the longitudinal ways. This table moves back and forth to traverse the work longitudinally along the width of the grinding wheel.

An adjustable taper table, located on top of the sliding table is used to grind long (small angle) tapers





28.252

Figure 10-11.—Cylindrical grinder (with workhead and footstock mounted).

on the workpiece. Adjust the taper table like the taper attachment on a lathe. Clamp workholding devices on top of the taper table.

The motor-driven workhead is mounted on the taper table. This component holds and rotates the work during the grinding cut. To meet the requirements of a job, you may need to change the speed at which the workpiece rotates. The workhead has variable-speed drive motors or step pulleys for this purpose.

You may use a chuck, a center, or a faceplate to mount work on the workhead. You also may use center rests and steady rests in conjunction with the workhead to mount long workpieces for cylindrical grinding.

On most cylindrical grinders used by the Navy, the workhead is mounted on a swivel base. This allows you to set the work to grind relatively large taper angles.

### WHEELHEAD

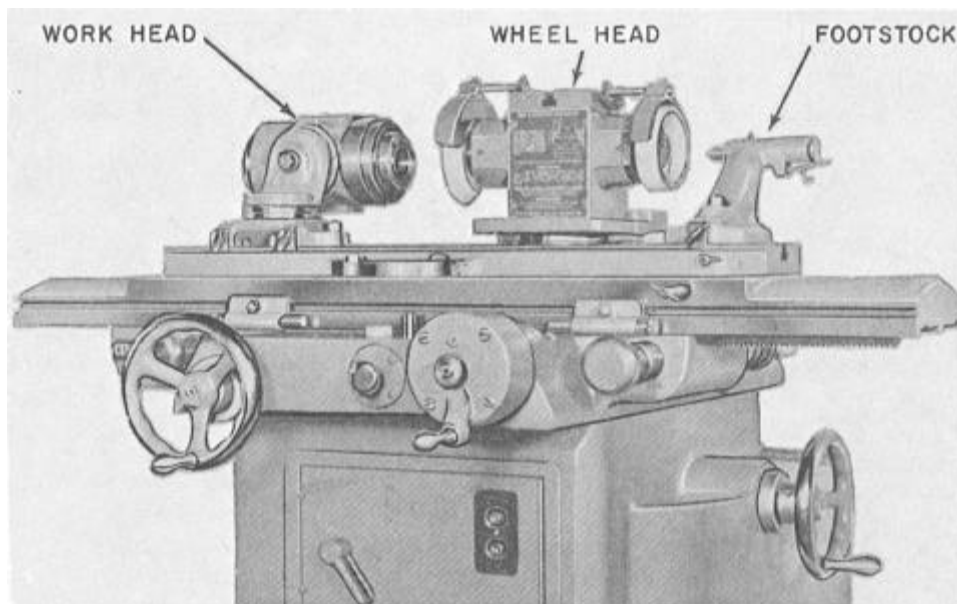
The wheelhead of a cylindrical grinder moves on the horizontal ways (platen). Since cylindrical grinding is done with the axis of the spindle level with the center of the work, there is no need for vertical movement of the wheelhead. Some wheelheads are mounted on swivel bases to provide versatility in taper and angle grinding setups.

### CYLINDRICAL GRINDER OPERATION

The methods used to set up stock in a cylindrical grinder are similar to the methods used to set up lathes. If you plan to grind work between centers, you will usually machine it to approximate size between centers on a lathe. Then, you will use the same center holes for the grinding setup. Use center rests or steady rests (as applicable) to support long work or overhanging ends. You can hold short workpieces in chucks. If you need to do internal grinding (on machines that have an internal grinding spindle), hold the work in a chuck and use steady rests for any necessary support.

When you set up a workpiece to grind between centers, use the following procedures:

1. Be sure the centers in the workhead and footstock and the center holes in the workpiece are in good condition.
2. Clamp a driving dog onto the workpiece.
3. Position the workhead and footstock and set the traverse stop dogs so that when the workpiece is in place, the table will traverse (longitudinally) the proper distance to grind the surface.
4. Make sure the workhead swivel, the taper table attachment, and the wheelhead swivel are set properly.



28.253

Figure 10-12.—Tool and cutter grinder (workhead and footstock).

for straight cylindrical grinding or for the correct taper or angle, depending on the job.

5. Adjust the workhead speed mechanism to get the proper rotational speed. Normally, you should use a slow speed for roughing and a high speed for finishing.

6. Set the longitudinal traverse speed so the work advances from two-thirds to three-fourths the thickness of the wheel during each revolution of the workpiece. Use a fast traverse feed for roughing and a slow feed for finishing.

7. Set the workpiece in place and clamp the footstock spindle after making sure that both centers are seated properly and that the driving dog is not binding.

8. Select and mount the grinding wheel.

9. Start the spindle motor, hydraulic power pump, and coolant pump. After the machine has run for a few minutes, start the coolant flow and dress the wheel.

10. Using the cross traverse mechanism, bring the wheel up to the workpiece and traverse the table longitudinally by hand to see that the wheel will travel through the cycle without hitting any projections. (About one-half of the wheel width should remain on the work at each end of the longitudinal traverse stroke.) Clamp the table dogs in the correct positions to limit longitudinal traverse.

11. Start the workhead motor and feed the grinding wheel in sufficiently to make a cleanup cut (a light cut the entire length of the surface to be ground).

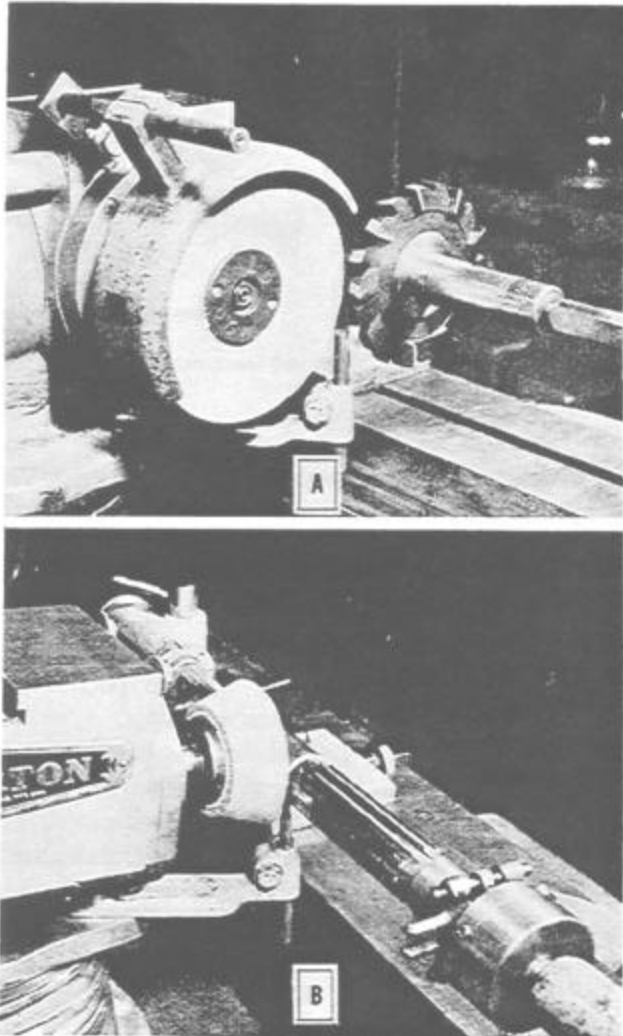
12. Using power longitudinal traverse, take a cut. Then, disengage the power traverse, stop the workhead motor and wheelhead rotation, and check the workpiece for taper. Make any changes required. (If you are using the taper table attachment and you need to make an adjustment at this point, dress the wheel again.)

We have not provided specific information on how to set the various controls and speeds because there are variations for each machine. Look for this information in the manufacturer's technical manual for your machine.

## TOOL AND CUTTER GRINDER

The tool and cutter grinder (fig. 10-12) has a combination of the features of the plain cylindrical grinder and the planer-type surface grinder. A tool and cutter grinder is used primarily to grind multiedged cutting tools, such as milling cutters, reamers, and taps. The worktable has the same basic construction features as the surface grinder, but a taper table is mounted on the sliding table so you can grind tools that have small tapers, such as tapered reamers.

You can adjust the wheelhead in two directions. You can move it vertically on its support column through 360°. If you need to change the rotational direction of the grinding wheel, simply rotate the wheelhead 180°.



28.253A

**Figure 10-13.—Tool grinding setups on a tool and cutter grinder. A. Straight wheel grinding a milling cutter. B. Cup wheel grinding a reamer.**

Also, the spindle is double ended, allowing you to mount two wheels on the wheelhead.

The basic workholding devices used on the tool and cutter grinder are the workhead and the footstock (fig. 10-12). When there is no workhead, you can use a left-hand footstock similar to the right-hand footstock shown mounted on the table in figure 10-12. Also, you will have a variety of tooth rests to support and guide the teeth of a cutter being sharpened.

Most tool and cutter grinders have control handwheels at both the back and the front of the machine. These dual controls permit you to stand in the most convenient position to view the work while you operate the machine. You can usually disengage the sliding table handwheel to push the table back and forth by hand. Graduated collars on the handwheels offer a

Deleted—No permission granted for electronic copy.

**Figure 10-14.—Direction of wheel rotation. A. Toward the cutting edge. B. Away from the cutting edge.**

quick visible guide to show you the amount of movement of the various feed components.

## CUTTER SHARPENING

The working efficiency of a cutter is largely determined by the keenness of its cutting edge. Therefore, you should sharpen a cutter at the first sign of dullness; this practice is both economical and a sign of good workmanship. A dull cutter not only leaves a poorly finished surface, but also may be damaged beyond repair if you continue to use it in that condition. Here is a good rule to help you decide when to sharpen a cutter; sharpen it when the wear land on the cutting edge is between 0.010 and 0.035 inch.

Cutters to be sharpened may be divided into two groups: (1) those that are sharpened on the relief and (2) those that are sharpened on the face. The first group includes cutters such as plain milling, side milling, stagger tooth, angle, and end nulls. The second group includes the various form cutters such as involute gear cutters and taps. The manufacturer provides the relief on the second type of cutter by grinding the faces of the teeth to sharpen them.

Figure 10-13 shows two methods used to grind cylindrical cutting tools on a tool and cutter grinder. View A shows a setup to grind a staggered tooth cutter using a straight wheel. View B shows a setup to grind a reamer using a cup type wheel. You can use either type of wheel; the cup-type produces a straight clearance angle; the straight wheel produces a hollow ground clearance angle.

When you use the straight wheel, set the spindle parallel to the table. When you use a flaring cup wheel, turn the spindle at an angle of  $89^\circ$  to the table. This provides the necessary clearance for the trailing edge of the grinding wheel as it is traversed along the cutter.

When you grind a cutter, you should have the grinding wheel rotating as shown in view B of figure 10-14. This method tends to keep the tooth of the cutter

Figure 10-15.—Typical tooth rest blades.

firmly against the tooth rest, ensuring a correct cutting edge. If this method causes too much burring on the cutting edge, you may reverse the direction of wheel rotation as shown in view A. If you use the latter method, be sure the tooth being ground rests firmly on the tooth rest during the cut.

### Dressing and Truing

You will usually need a soft grade wheel to sharpen a high-speed steel cutter or reamer. A soft grade wheel breaks down easily and is less likely to burn the cutter. True and dress the wheel before you start the sharpening operation and then redress as necessary, depending on the amount of wheel wear. As you grind each cutter tooth, the grinding wheel diameter decreases because of wear. As a result, you will remove less metal and the teeth will gradually increase in size.

To compensate for wheel wear and to be sure all the teeth are the same size, rotate the cutter 180° and grind all the teeth again. Be careful not to grind the cutter undersize.

To ensure a good cutting edge on the cutter, there must be a good finish on the clearance angle; therefore, you will occasionally need to dress the grinding wheel. Use the wheel truing attachment for this operation and for the initial truing and dressing operation on the wheel.

### Tooth Rest Blades and Holders

Tooth rest blades are not carried in stock, so you must make them in the shop. Once you understand the requirements for the blades, you can fabricate various shapes to suit the types of cutters you will sharpen. Normally, these blades should be made of spring steel.

Use a plain (straight) tooth rest blade (view A, fig. 10-15) to sharpen side milling cutters, end mills, straight-fluted reamers, or any straight-fluted cutter. Use a rounded tooth rest blade (view B, fig. 10-15) for

Figure 10-16.—L-shaped tooth rest blade.

helix cutters, shell end mills, and small end mills. The offset tooth rest blade (view C, fig. 10-15) is a universal blade and you can use it for most applications. Figure 10-16 shows an L-shaped tooth rest blade used to sharpen metal slitting saws and straight tooth plain milling cutters with closely spaced teeth. You can make other shapes of tooth rest blades to fit the specific type of cutter or the cutter grinder you are using.

HOLDERS for the tooth rest blades may be either plain or universal. Figure 10-17, view A, shows a tooth rest blade in a plain holder and view B shows a tooth rest blade in a universal-type holder. The universal tooth rest holder has a micrometer adjustment at its bottom to help you make precise up and down movements in the final positioning of the blade.

### Setting the Clearance Angle

It is essential that the back of the cutting edge of any cutter have correct clearance. If it has too little clearance, the teeth will drag, causing friction and slow cutting. Too much clearance produces chatter and dulls the teeth rapidly. The cutting edge must have strength, and the correct clearance will provide this strength. Figure 10-18 shows a typical cutter tooth and the angles produced by grinding.

The primary clearance angle is the angle you grind when you sharpen a cutter. The number of degrees in the primary clearance angle vary according to the diameter of the cutter and the material being cut. A large diameter cutter requires less clearance than a small cutter. Cutters used to cut hard materials such as alloy and tool steels require less clearance than cutters used to cut softer materials such as brass and aluminum.

The primary clearance angles range from 4° for a large cutter to 13° for a smaller cutter. Some manufacturers of tool and cutter grinders have charts that can help you determine the correct clearance angle. The width of the primary land (the surface created when you

Deleted—No permission granted for electronic copy.

Figure 10-17.—A. Tooth rest blade in a plain holder. B. Tooth rest blade in a universal holder.

grind the primary clearance angle) varies according to the size of the cutter. Primary land widths range from 0.0005 to 0.015 inch for a small cutter to 0.030 to 0.062 inch for a large cutter. You should grind the lands very carefully. A land that is too narrow will allow the cutting edge to chip or wear rapidly. A land that is too wide will cause the trailing side (heel) of the land to rub the work.

When the width of the primary land becomes excessive due to repeated grindings, you must grind the secondary clearance angle to reduce it. The secondary clearance angle is normally  $3^{\circ}$  to  $5^{\circ}$  greater than the primary clearance angle.

You get the desired clearance angle by the positioning of the grinding wheel, the cutter, and the tooth rest. The general procedure is to position the center of the wheel, the center of the work, and the tooth

rest all in the same plane and then raise or lower the wheelhead the proper distance to give the desired clearance angle.

When you use the straight wheel, use a centering gauge (fig. 10-19) or a height gauge to bring the center of the wheel and the center of the work into the same plane. Then, fasten the tooth rest to the machine table and adjust the tooth rest to the same height as the center

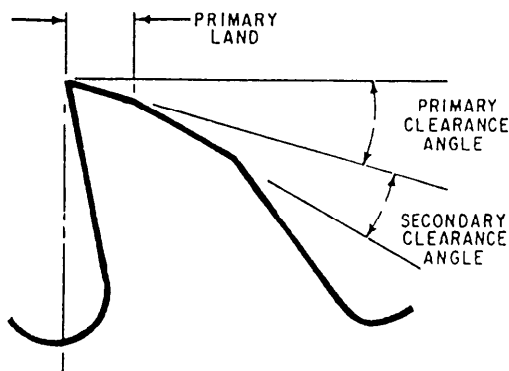


Figure 10-18.—Cutter clearance angles.

Deleted—No permission granted for electronic copy.

Figure 10-19.—Centering gauge.

of the work. Raise or lower the wheelhead a pre-determined amount to give the correct clearance angle. To determine the amount to raise or lower the wheelhead, multiply the clearance angle (in degrees) by the diameter of the wheel (inches) and then multiply this product by the constant 0.0087.

When you use a cup wheel, mount the tooth rest on the wheelhead. Position the center of the cutter in the same plane as the tooth rest. Then, raise or lower the wheelhead the proper amount to give the desired clearance. To determine the amount to raise or lower the wheelhead, multiply the clearance angle (in degrees) by the diameter of the cutter (in inches) and then multiply this product by the constant 0.0087.

Some tool and cutter grinders have a tilting wheelhead or a clearance setting device. Where you use a tilting wheelhead, simply tilt the wheelhead to the desired clearance angle. If you use a clearance setting device, follow the steps listed here.

1. Clamp a dog to the mandrel on which the cutter is mounted.
2. Insert the pin on the side of the dog into the hole in the clearance setting plate that is mounted on the footstock.
3. Loosen the setscrew in the clearance setting plate and rotate the cutter to the desired setting (graduations found on the clearance setting plate).
4. Tighten the setscrew.
5. Remove the dog.

When you grind the teeth of end mills, side milling cutters, or stagger tooth cutters, use the graduated dials on the workhead to set the clearance angle.

## **CUTTER SHARPENING SETUPS**

Tool and cutter grinders vary in design and in the type of accessory equipment; however, most tool and cutter grinders operate in the same way. By using only the standard workhead, footstocks, and tooth rest blade holders, you can sharpen practically any cutter. In fact, you can sharpen most cutters by using essentially the same method. Study the following sections, use a little ingenuity and forethought, and you will be able to sharpen any cutter that may be sent to your shop.

The following sections cover the sharpening of various types of cutters in various depths of detail. We have provided more detail in the explanation of how to sharpen a plain milling cutter with helical teeth because this method is basically used to sharpen many other cutters.

## **Plain Milling Cutters (Helical Teeth)**

Follow the steps listed here to sharpen plain milling cutters with helical teeth:

1. Remove all accessory equipment from the machine table.
2. Clean the table and the bottoms of the footstocks.
3. Mount the footstocks on the table. Allow just enough space between them to accommodate the mandrel with a slight amount of tension on the spring-loaded center.
4. Swivel the wheelhead to 89°. (This allows the end of the cutter to clear the opposite cutting face when you use a cup-type wheel.)
5. Mount the wheel and the wheel guard.
6. Use a dressing stick to thin the cutting face of the wheel to not more than 1/8 inch. Use a diamond truing device to true the wheel.
7. Use the centering gauge to bring the wheelhead axis into the same horizontal plane as the axis of the footstock centers.
8. Mount the cutter on a mandrel. (A knurled sleeve on the end of the mandrel will help the mandrel maintain an even, effective grip while you grind the cutter.)
9. Mount the mandrel between the footstock centers, preferably in a position so that the grinding wheel cuts onto the cutting edge of the teeth.
10. Mount the plain tooth rest holder (with a rounded tooth rest blade) on the wheelhead.
11. Place the centering gauge on top of the wheelhead and the tip of the gauge directly in front of the cutting face of the wheel, and then adjust the tooth rest blade to gauge height. (This brings the blade into the same horizontal plane as the footstock centers.)
12. Traverse the saddle toward the wheelhead until one tooth rests on the tooth rest blade; then lock the table into position.
13. Let a cutter tooth rest on the tooth rest, and then lower the wheelhead until the desired clearance is shown on the clearance setting plate. If you have no clearance setting device, calculate the distance to lower the wheelhead using the method described earlier in this chapter.



Figure 10-20.—Grinding the side teeth of a side milling cutter.

Before you start the sharpening operation, run through it without the machine running. This will let you get the feel of the machine and assure you that there is nothing to obstruct the grinding operation. Traverse the table with one hand and use the other hand to hold the cutter against the tooth rest blade. On the return movement, the tooth rest blade will cause the mandrel to turn in your hand; this eliminates the need to move the table away from the wheel on the return traverse.

To sharpen the teeth of any milling cutter, grind one tooth; then rotate the cutter  $180^\circ$  and grind another tooth. Check the teeth with a micrometer to be sure you are not grinding a taper. If there is taper, you must remove it by swiveling the swivel table of the machine.

As the width of the land increases with repeated sharpening, you will need to grind a secondary land on the cutter. Never allow the primary land to become greater than  $1/16$  inch wide, because the heel of the tooth may drag on the work. To control the width of the

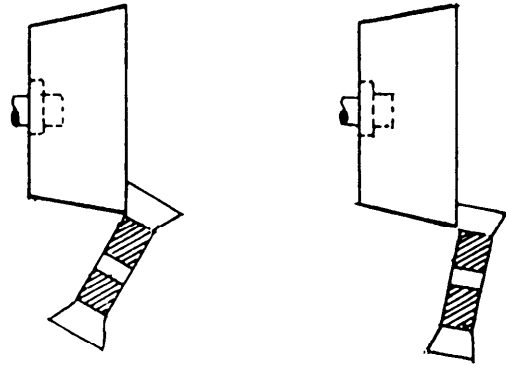


Figure 10-21.—Changing clearance angle by swiveling the cutter in a vertical plane.

primary land, double the clearance angle and grind a secondary land.

### Side Milling Cutters

The peripheral teeth of a side milling cutter are ground in exactly the same manner as the teeth of a plain milling cutter, with the exception that you will use a plain tooth rest blade.

To sharpen the side teeth, mount the cutter on a stub arbor and clamp the arbor in a universal workhead. Then, mount a universal tooth rest holder onto the workhead so that when the workhead is tilted the tooth rest holder moves with it (fig. 10-20).

The procedure used to grind clearance angles varies, depending on the type of grinding wheel used. If you are using a cup wheel, swivel the workhead vertically to move the tooth toward or away from the wheel. The clearance angle increases as the tooth is swivelled away from the wheel (fig. 10-21). If you use a straight wheel, set the cutter arbor horizontally and raise or lower the wheel to change the clearance angle. The clearance angle increases as the wheel is raised (fig. 10-22).

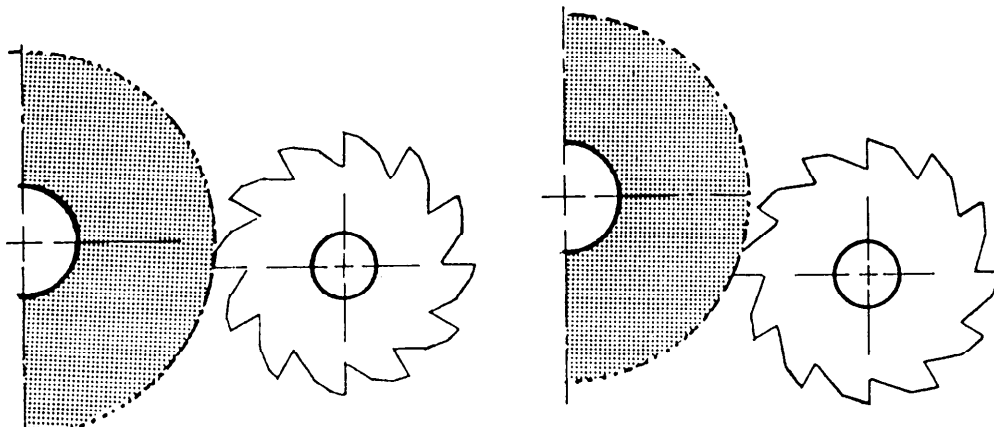


Figure 10-22.—Changing the clearance angle by raising the grinding wheel.

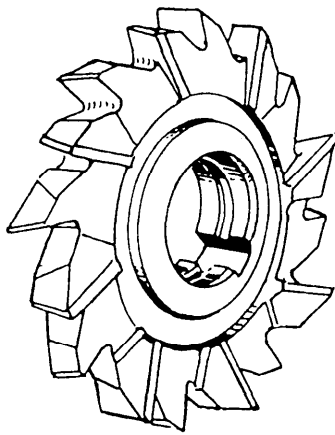


Figure 10-23.—Staggered-tooth side milling cutter.

### Staggered Tooth Cutters

You can sharpen staggered tooth milling cutters (fig. 10-23) in exactly the same manner as plain milling cutters with helical teeth (fig. 10-24). If you use this method, grind all of the teeth on one side of the cutter. Then, turn the cutter over and grind all of the teeth on the other side.

There is, however, a method you can use to sharpen all of the cutter's teeth in one setting (see setup, fig. 10-13, view A). Follow the steps listed here:

Deleted—No permission granted for electronic copy.

Figure 10-24.—Tooth rest mounted on the wheelhead in grinding a helical-tooth cutter.

1. Mount the cutter on a mandrel held between centers.
2. Fasten the tooth rest holder to the wheelhead.
3. Grind the tool rest blade to the helix angle of the cutter teeth on each side of the blade (fig. 10-25).

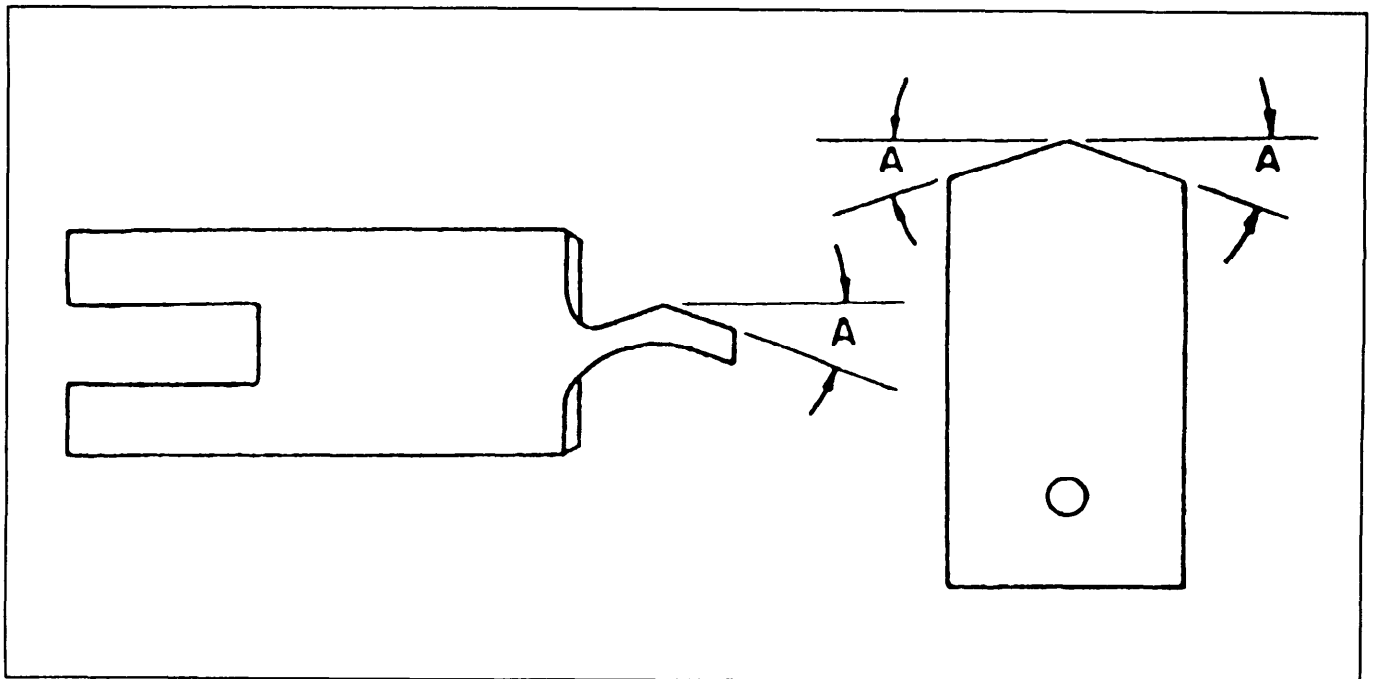


Figure 10-25.—Tooth rest blades for staggered tooth cutters.



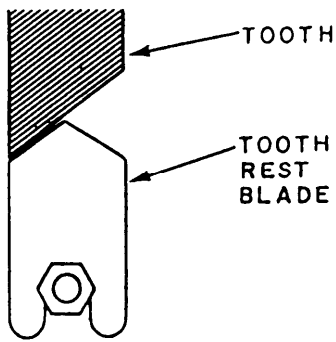


Figure 10-26.—Resting the face of a tooth on its corresponding side of the tooth rest blade.

4. Position the high point of the tooth rest blade in the center of the cutting face of the wheel.
5. Align the wheelhead shaft center line, the footstock centers, and the high point of the tooth rest blade in the same horizontal plane.
6. Raise or lower the wheelhead to give the desired clearance angle.
7. Rest the face of a tooth on its corresponding side of the tooth rest blade (fig. 10-26).

8. Move the cutting edge of the tooth across the face of the wheel. On the return cut, rest the next tooth on the opposite angle of the tooth rest. Continue alternating teeth on each pass until you have sharpened all the teeth.

### Angular Cutters

To sharpen an angular cutter, mount the cutter on a stub arbor and mount the arbor in a universal workhead. Then, swivel the workhead on its base to the angle of the cutter. If the cutter has helical teeth, mount the tooth rest on the wheelhead. But, if the cutter has straight teeth, mount the tooth rest on the table or on the workhead. To set the clearance angle for both types of teeth, tilt the workhead the required number of degrees toward or away from the grinding wheel. Then, use a centering gauge to align the cutting edge of one tooth parallel with the cutting face of the wheel. Take a light cut to check your settings, and make fine adjustments until you get the desired clearance angle.

### End Mills

You may salvage a damaged end mill by cutting off the damaged portion with a cylindrical grinding attachment, as shown in figure 10-27. Use a coolant if

Deleted—No permission granted for electronic copy.

Figure 10-27.—Cutting off the damaged end of a helical end mill.

Deleted—No permission  
granted for electronic copy.

**Figure 10-28.—Grinding the peripheral teeth of an end mill.**

Deleted—No permission  
granted for electronic copy.

**Figure 10-29.—Grinding the end teeth of a shell end mill.**

possible to avoid removing the temper at the end of the cutter. Be sure to relieve the center of the end in the same way as on the original cutter.

Generally, it will not be necessary to sharpen the peripheral teeth. However, if you must grind them, use

the same procedure that you would use to sharpen a plain milling cutter except for the method of mounting the cutter. Mount the end mill in a universal workhead (fig. 10-28) instead of between centers. You must remember that whenever you grind the peripheral teeth

of an end mill, you change the size (diameter) of the cutter. Therefore, you must show that the cutter size has been changed. Either mark the new size on the cutter or grind off the old size and leave the cutter unmarked.

Use the following steps to sharpen the end teeth:

1. Mount the end mill in a universal workhead.
2. Swivel the wheelhead to 89°.

3. Use a centering gauge to bring the cutting edge of a tooth into the same horizontal plane as the wheelhead spindle axis. Place the gauge on top of the wheelhead and raise or lower the wheelhead enough to place the blade of the gauge on the tooth's cutting edge. This also will align the cutting edge with the centerline of the wheel.

4. Lock the workhead spindle in place to prevent the cutter from moving.

5. Clamp the tooth rest blade onto the workhead so that its supporting edge rests against the underside of the tooth to be ground.

6. Swivel the workhead downward to the desired clearance angle and clamp it in position. At this point, make sure the tooth next to the one being ground will clear the wheel. If it does not, raise or lower the wheelhead until the tooth does clear the wheel.

7. Unclamp the workhead spindle and begin grinding the mill.

8. After you have ground all of the primary lands, tilt the workhead to the secondary clearance angle and grind all the secondary lands.

On end mills with large diameter wheels, it is often a good idea to back off the faces of the teeth toward the center of the cutter, similar to the teeth of a face mill. An angle of about 3° is enough, allowing a land of 3/16 to 5/16 inch long.

You must use as much care when you grind the comers of the teeth as when you grind the faces of the peripheral teeth. If not, the cutting edges will dull rapidly, and they will produce a poor finish. The comers of the teeth are usually chamfered 45° by swiveling the workhead or table and are left 1/6 to 1/8 inch wide.

To sharpen the end teeth of a shell end mill (fig. 10-29), mount the cutter on an arbor set in a taper shank mill bushing. Then, insert the bushing into the taper shank mill bushing sleeve held in the universal workhead. To get the desired clearance angle, swivel the workhead in the vertical plane and swivel it slightly in the horizontal plane to grind the teeth low in the

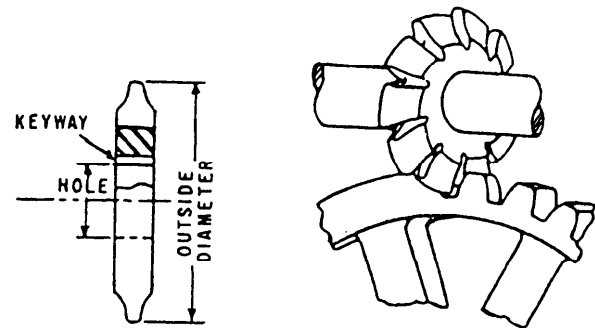
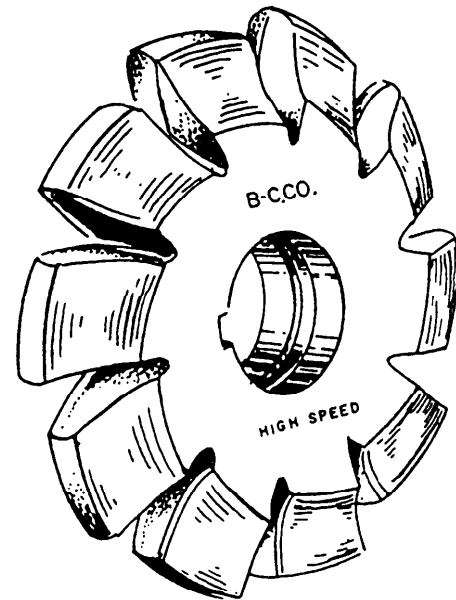


Figure 10-30.—Involute gear cutter.

center of the cutter. Turn the cutter until one of the teeth is horizontal; then raise the wheel until that tooth can be ground without interference.

### Formed Cutters

Two methods are commonly used to sharpen formed milling cutters. The first method uses a formed cutter sharpening attachment and is by far the most convenient. In the second, set up the cutter on a mandrel, grind the backs of the teeth, and then reverse the cutter to sharpen the cutting faces.

The involute cutter (fig. 10-30) will serve as an example. Since the teeth of these cutters have a specific shape, the only correct way to sharpen them is to grind their faces. It is most important that the teeth are ground uniformly and that they all have the same thickness from the back face to the cutting face. To get this uniformity, grind the back faces of all new cutters before you use them. Grind only the back faces, since the cutting faces are already sharp and ready to use.

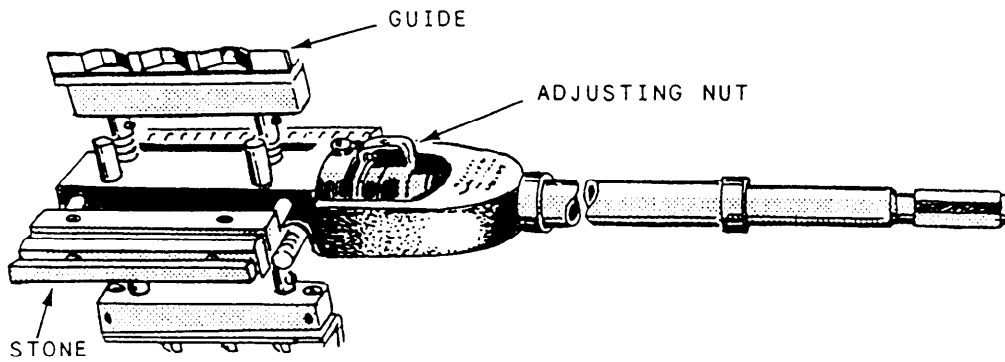


Figure 10-31.—Portable hone.

Once the teeth are uniform, they should remain uniform through repeated sharpening because you will be taking identical cuts on the cutting faces whenever you sharpen the cutter.

To sharpen a formed cutter using the formed cutter sharpening attachment, attach the wheelhead shaft extension to the shaft and mount a dish-shaped wheel on the extension. With the wheelhead swiveled to 90°, clamp the attachment to the table with the pawl side of the attachment away from the wheel. Place the cutter on a stud and line up the cutting face of a tooth with the attachment centering gauge. Loosen the pawl locking knob and adjust the pawl to the back of the tooth. Then, adjust the saddle to bring the face of the tooth in line with the face of the grinding wheel. Once you have made this adjustment, do not readjust the saddle except to compensate for wheel wear. Grind one tooth, move the saddle away from the wheel, index to the next tooth, and grind that one. If you grind all of the teeth once and they have not been ground enough, rotate the tooth face toward the wheel and make a second cut on each tooth.

If a cutter has been initially provided with a radial rake angle, this angle must be retained or the cutter will not cut the correct form. To sharpen this type of cutter, line up the point of one cutter tooth with the attachment gauge, swivel the table to the degree of undercut, adjust the saddle to bring the face of the tooth in line with the face of the wheel, and grind.

If you don't have a formed cutter sharpening attachment, you can sharpen formed cutters by using a setup similar to that used to sharpen a plain milling cutter—between centers on a mandrel. In this method, the setup used to grind a radial tooth formed milling cutter is essentially the same as that used to grind a tap.

## HONING EQUIPMENT

In honing, abrasive action does the cutting. You can use honing to remove stock from a drilled, bored, reamed, or ground hole to correct taper, out-of-roundness, or bow (bell-mouthed, barrel shape or misalignment). You can also use honing to develop a highly smooth finish while accurately controlling the size of the hole.

You may do cylindrical honing on a honing machine or on some other machine tool by attaching the honing device to the machine spindle, or you may do it by hand. Regardless of the method, either the hone or the work must rotate, and the honing tool must move back and forth along the axis of rotation.

## PORTABLE HONING EQUIPMENT

The portable hone shown in figure 10-31 is similar to the type used in most Navy machine shops. It is normally available in sizes ranging from 1 3/4 to 36 inches, and each hone set is adjustable to cover a certain range within those sizes. The hone in figure 10-31 has two honing stones and two soft metal guides. The stones and the guides advance outward together to maintain a firm cutting action. An adjusting nut just above the stone and guide assembly is used to regulate the size of the honed bore. You can achieve accuracy to within 0.0001 inch when you follow the operating procedures.

To use the portable hone, follow these basic steps:

1. Clamp the hone shaft in the drill press chuck.
2. Clamp the workpiece to the drill press table.
3. Put the hone into the hole to be polished. Use honing compound as required.
4. Turn on the drill press and use the drill press feed handle to move the rotating hone up and down in the hole.

When you use a lathe (vertical or horizontal) to hone, you can mount the work in a chuck or on a faceplate and rotate it. In this arrangement, you will hold the honing tool in the tailstock with a chuck and use the tailstock spindle to move it back and forth in the workpiece bore.

When you use a milling machine or a horizontal boring mill, mount the workpiece on the table and the honing tool in the spindle. Move the machine table to pass the hone back and forth in the workpiece bore.

You also can use a hand-held power drill to rotate the hone in the workpiece. Move the rotating hone in and out of the hole by hand.

Each of these methods requires that the hone be allowed to self-align with the workpiece bore. To help this process, place one or two universals between the hone shaft and the device or spindle that will hold or drive the hone. Hone manufacturers can usually furnish these universals and shaft extensions.

When you hone large bores, use a device that attaches to the hone and lends support to the stones and guides to ensure a rigid setup.

## STATIONARY HONING MACHINE

Most large machine shops have a stationary honing machine such as the one shown in figure 10-32. These machines are usually self-contained hones with a built-in honing oil pump and reservoir, a workholding device, and a spindle to rotate and stroke the honing stones. They usually have standard controls to adjust the rpm, the rate of stroke, and the pressure feeding the stones to the desired size. Most models have a zero setting dial indicator that lets you know when the desired bore size is reached. Follow your machine manufacturer's operating manual.

## STONE SELECTION

The honing stone is made somewhat like a grinding wheel, with grit, a bond, and air voids. The grit is the cutting edge of the tool. It must be tough enough to withstand the pressure needed to make it penetrate the surface, but not so tough that it cannot fracture and sharpen itself. The bond must be strong enough to hold the grit, but not so strong that it rubs on the bore and interferes with the cutting action of the grit. Air voids in the structure of the stone help the coolant or honing oil clear chips and dissipate heat.

Honing stones have either aluminum oxide grit for ferrous metals or silicon carbide grit for nonferrous



28.478

Figure 10-32.—Stationary honing machine.

metals and glass. Grit sizes range from 150 to 400. If you need to remove a large amount of metal, use a coarse grit stone such as a 150-grit to bring the base to within 0.0002 to 0.001 inch of the finish size. Then, use a finer grit stone to get a smooth finish. The hone manufacturer will recommend stones needed for specific jobs.

## HONING HINTS

Honing does not change the axial location of a hole. The center line of the honing tool aligns itself with the center line of the bore. Either the tool or the part floats to ensure that the tool and the base align. Floating allows the tool to exert equal pressure on all sides of the bore.

As the honing tool is stroked through the bore, the pressure of the grit is greatest at the tight spots. Therefore, the hone takes out all taper and out-of-roundness before it removes any stock from the larger section of the bore. It also takes out any bow. Since the honing stones are rigid throughout their length, they cannot follow a bow—they bridge the low spots and cut deeper on the high spots, tending to straighten out a bow.

After you have honed out the inaccuracies, you must abrade every section of the bore equally. To be sure this happens, maintain both the rotating and reciprocating motions so that every part of the bore is covered before any grit repeats its path of travel.

If a bore will require honing to correct taper or out-of-roundness, leave about twice as much stock for honing as there is error in the bore. It is sometimes practical and economical to perform two honing operations: (1) rough honing to remove stock and (2) finish honing to develop the desired finish. We said earlier that you should leave from 0.0002 to 0.001 inch for finish honing.

If a machined bore must be heat-treated, rough hone it before heat treating to produce an accurately sized,

round, and straight bore. After heat-treating the work-piece, finish hone to correct any minor distortion and to produce the desired finish.

Honing produces a crosshatch finish. The depth of cut depends on the abrasive, speed, pressure, and coolant or honing oil used. To produce a finer finish, you can do one or all of the following:

1. Use a finer grit stone.
2. Increase the rotating speed.
3. Decrease the stroking speed.
4. Decrease the feed pressure
5. Increase the coolant flow.

## CHAPTER 11

# COMPUTER NUMERICAL CONTROL MACHINES

### CHAPTER LEARNING OBJECTIVES

*Upon completing this chapter, you should be familiar with the following:*

- *Set up CNC lathes and milling machines.*
- *Develop CNC lathe and milling machine programs using CAD/CAM.*

As the hardware of an advanced technology becomes more complex, new approaches to the processing of materials into useful products come into common use. This has been the trend in machining processes in recent years. Parallel development in other technologies such as electronics and computers have made available to the machine tool designer methods and processes that can permit a machine tool to far exceed the capabilities of the most experienced machinist. To state it very simply, the MR rate has gone from the horse and buggy days to the space shuttle days almost overnight.

This chapter will give you some information on the impact numerical control (NC) has had in the field of machining. It is only an overview and cannot be expected to take the place of a programming manual for a specific machine, on-the-job training, or MR "C" school.

With the development of NC, a variety of input media has been used to convey the information from the print to the machine. The most common types of input media used in the past were magnetic tape, punched cards, and punched tape. However, most of the new machines are controlled by computers. All of the machines on board Navy intermediate maintenance activities (IMAs) are computer numerical control (CNC).

There are many advantages to using NC machines. The greatest advantage in NC machining comes from the unerring and rapid positioning movements possible. An NC machine does not stop at the end of a cut to plan its next move. It does not get fatigued and is capable of uninterrupted machining, error free, hour after hour. In the past, NC machines were used for mass production. With the introduction of CNC, a qualified machinist can program and produce even a single part economically.

### NC MACHINE SAFETY

All safety rules that apply to conventional machine tools also apply to NC machines. Always wear appropriate eye protection. Remove all rings, bracelets, watches, necklaces, and loose clothing that may be caught by moving or rotating equipment. Always wear safety shoes.

Always keep the work area around the machine clean and clear of obstructions. Do not use compressed air to clean the machine or the area around it; chips can become dangerous missiles. Never use machine surfaces as worktables. Use proper lifting methods to handle heavy workpieces. Take measurements only after the spindle has come to a complete stop. Never handle chips with your bare hands.

Before you start the machine, make sure the work-holding device and the workpiece are securely fastened. When changing cutting tools, protect the workpiece from damage, and protect your hands from sharp cutting edges. Make sure cutting tools are installed correctly.

Do not operate any machine controls unless you understand their function. All NC machines have electrical compartments; keep the doors closed to keep out dirt and chips. Only authorized technicians should perform maintenance or repairs in these compartments.

To avoid damage to the machine or workpiece, check the tool path by making a dry run through the program; that is, let the machine make all the positioning and cutting moves without a cutting tool installed.

Above all, follow all safety precautions posted on the machine and any listed in *Navy Occupational Safety and Health (NAVOSH) Program Manual for Forces Afloat*, OPNAV Instruction 5100.19B.

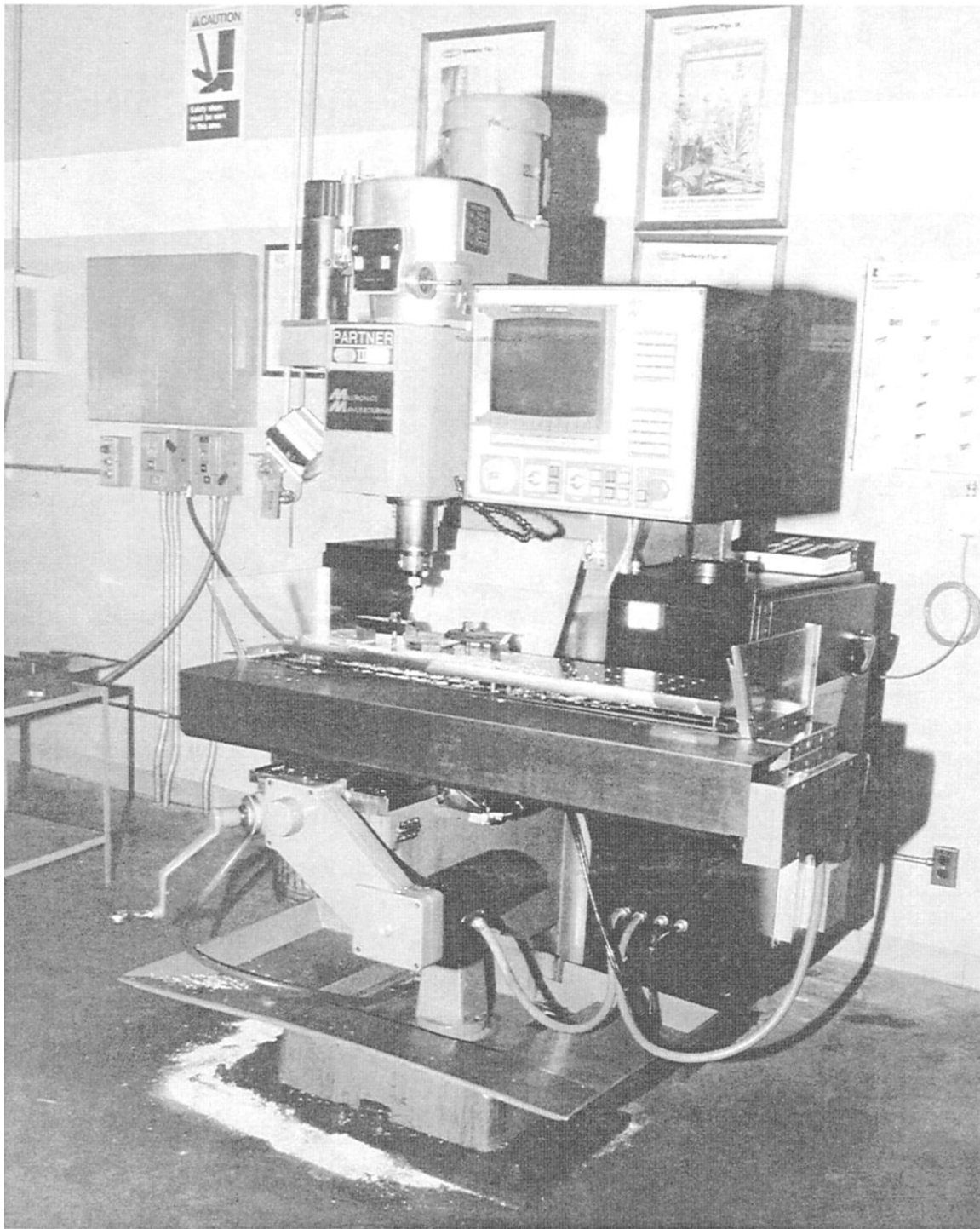


Figure 11-1.—CNC vertical spindle milling machine.

28.468

## MACHINES

With the rapid development of machining technology in the last few years, many new types of CNC machines have been introduced. Many of these

machines are not simply CNC machines, but are CNC turning centers. Turning centers may have one or more turret-type toolholders or have an automatic tool change system. For illustration purposes we will discuss a CNC vertical milling machine and a CNC lathe.





Figure 11-2.—CNC lathe.

28.469

### **CNC VERTICAL SPINDLE MILLING MACHINE**

Many of the CNC vertical spindle milling machines being introduced to the Navy today are similar to the one shown in figure 11-1. It is basically a vertical milling machine that has an onboard computer to control its motion. Most of these machines are manufactured with what is known as an R-8 spindle taper that employs a quick-change tool system.

The quick-change tool system consists of a quick release chuck (which is held in the spindle) and a set of toolholders that hold the individual tools needed for a particular part program. The chuck is a separate toolholding mechanism that stays in the spindle. During a

tool change, the toolholder is removed from the chuck and a toolholder containing the next required tool is installed in its place. Many varieties of quick-change tool systems are available on the market.

Since this is only a brief overview, we will not discuss each part of the machine. Refer to your machine's technical manual for more information.

### **CNC LATHE**

Many CNC lathes (fig. 11-2) look like traditional engine lathes. The lathe carriage rests on the ways. The ways are in the same plane and are parallel to the floor. On other CNC lathes, the turret tool post is mounted on

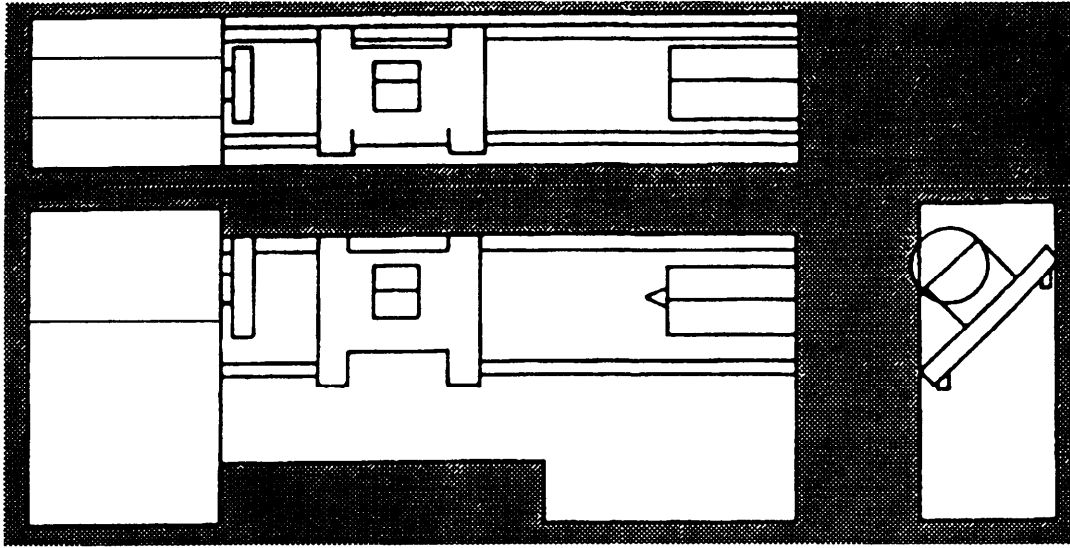


Figure 11-3.—Slant bed for CNC lathe.

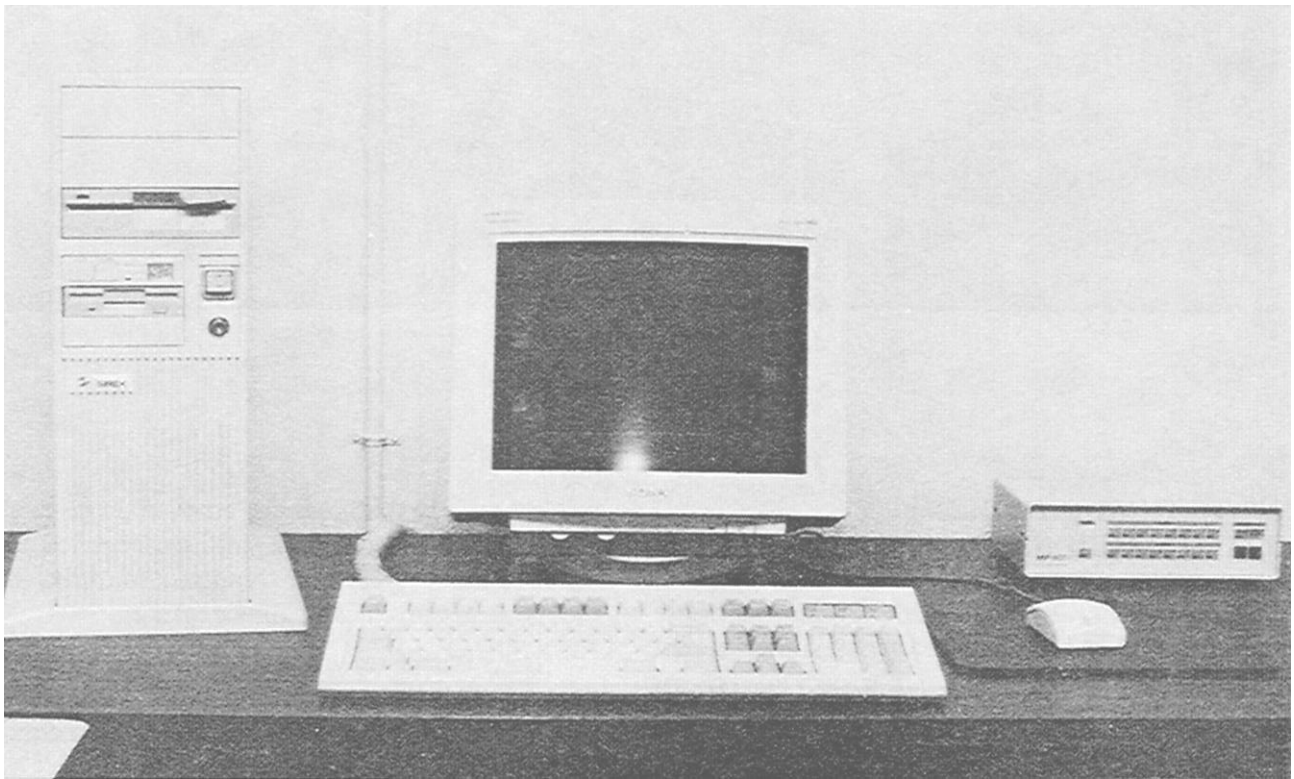


Figure 11-4.—CNC programming station.

28.470

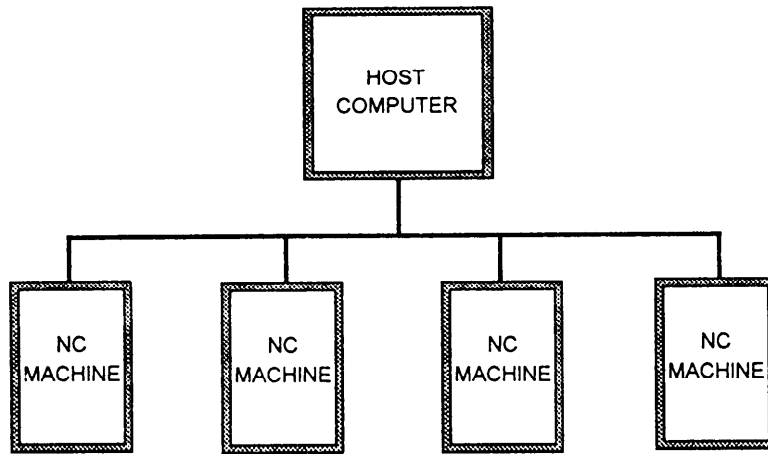


Figure 11-5.—Direct numerical control.

the opposite side of the saddle (fig. 11-3) and the machine has a slant bed. The slant bed allows the chips to fall into the chip pan, rather than on tools or bedways. Despite this odd appearance, the slant bed CNC lathe functions just like a conventional lathe.

As with CNC milling machines, you must have the controller manual for your machine's controller to program it and operate the machine.

### CNC TOOLING

There are many different tool-holding devices used for CNC machines. They can be as simple as a quick-change tool post or as complicated as an automatic tool change system, but they all serve the same purpose. The tool-holding devices for each shop will vary since each machine comes with different tooling and because shop personnel will purchase the tooling they prefer.

Cutting tools are available in three basic material types: high-speed steel, tungsten carbide, and ceramic. Since we covered cutting tools in chapter 5, we will only briefly discuss them now. High-speed steel is generally used on aluminum and other nonferrous alloys, while tungsten carbide is used on high-silicon aluminums, steels, stainless steels, and exotic metals. Ceramic inserts are used on hard steels and exotic metals. Inserted carbide tooling is becoming the preferred tooling for many CNC applications.

### COMPUTER-AIDED DESIGN/COMPUTER-AIDED MANUFACTURING

Computer technology has reached the stage where a machinist can use computer graphics (fig. 11-4) to

design a part. The computer is used to place the design elements (lines, curves, circles, and so on) and dimensions on the computer display screen.

The machinist defines the geometry of the part to the computer using one or more input devices. These devices may be the keyboard, a mouse, a digitizer, or a pen light. When the design has been edited and proofed, the computer can be instructed to analyze the geometry of the part and calculate the tool paths that will be required to machine the part. Each tool path is translated into a detailed sequence of machine axes movement commands that will enable a CNC machine tool to produce the part. No engineering drawing is required.

The computer-generated instructions can be stored in a central computer for direct transfer to a CNC machine tool for parts manufacture as shown in figure 11-5. This is known as direct numerical control (DNC). The data also can be stored on disk for future use.

The system that makes all this possible is computer-aided design/computer-aided manufacturing (CAD/CAM). There are several CAD/CAM software programs. They are constantly being upgraded and made more user friendly.

To state it simply, CAD is used to draw the part and to define the tool path. CAM is used to convert the tool path into codes that the computer on the machine can understand.

### NUMERICAL CONTROL SYSTEMS

A CNC machine consists of two major components: the machine tool and the controller, which is an onboard computer. These components may or may not be



Figure 11-6.—A typical CNC controller.

28.471

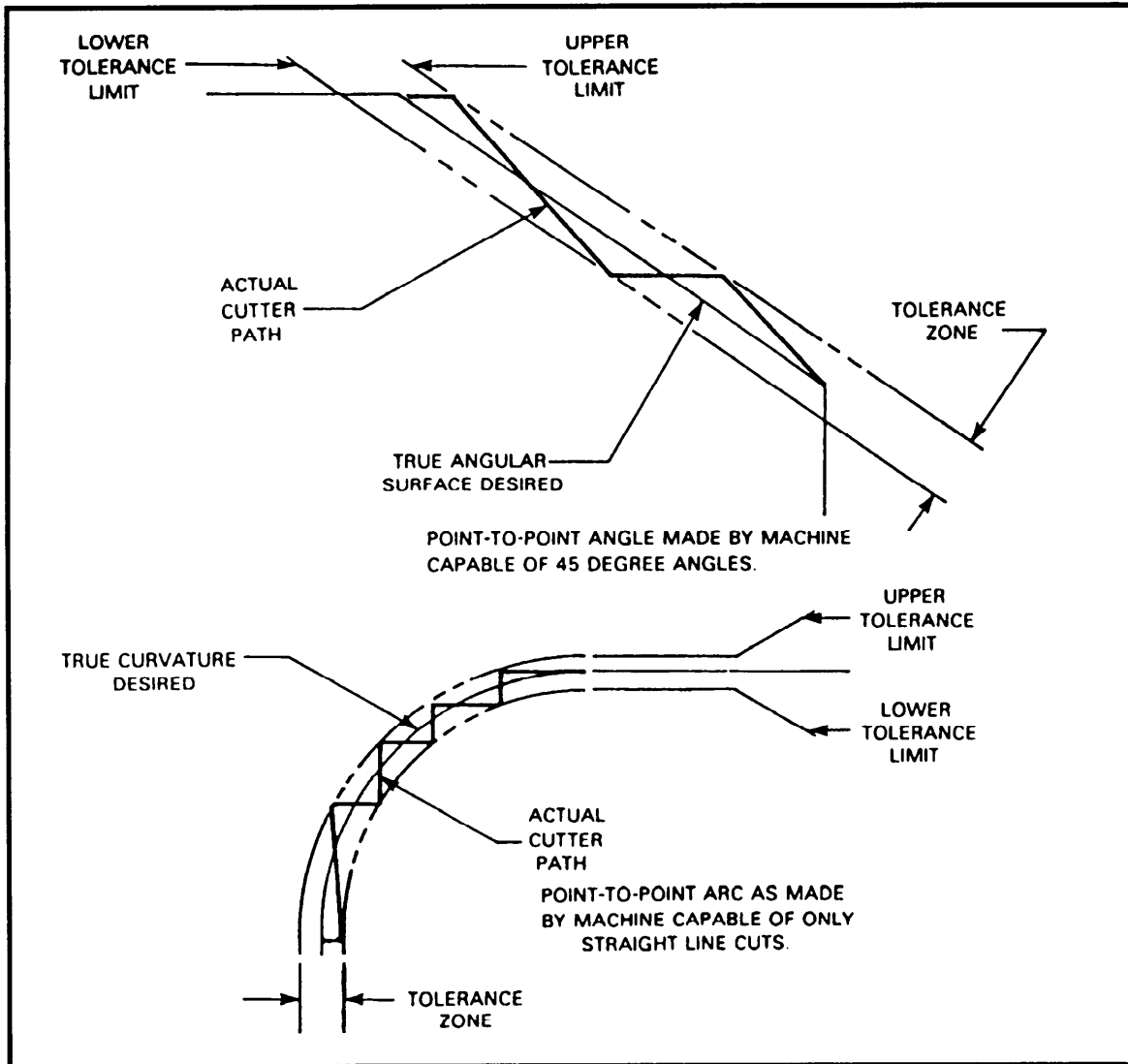


Figure 11-7.—Point-to-point angles and arcs.

manufactured by the same company. Figure 11-6 shows a typical controller. Each controller is manufactured with a standard set of built-in codes. Other codes are added by the machine tool builders. For this reason, program codes differ somewhat from machine to machine. Every CNC machine, regardless of manufacture, is a collection of systems coordinated by the controller.

## TYPES OF CONTROL SYSTEMS

There are two types of control systems used on NC machines: point-to-point systems and continuous-path systems.

Point-to-point machines move only in straight lines. They are limited in a practical sense to hole operations (drilling, reaming, boring, and so on) and straight milling cuts parallel to a machine axis. When making an axis move, all affected drive motors run at the same speed. When one axis motor has moved the instructed amount, it stops while the other motor continues until its axis has reached its programmed location. This makes the cutting of 45-degree angles possible, but not arcs or angles other than 45 degrees. Arcs and angles must be programmed as a series of straight line cuts, as shown in figure 11-7.

A continuous-path machine can move its drive motors at varying rates of speed while positioning the machine. Therefore, it can more easily cut arcs and

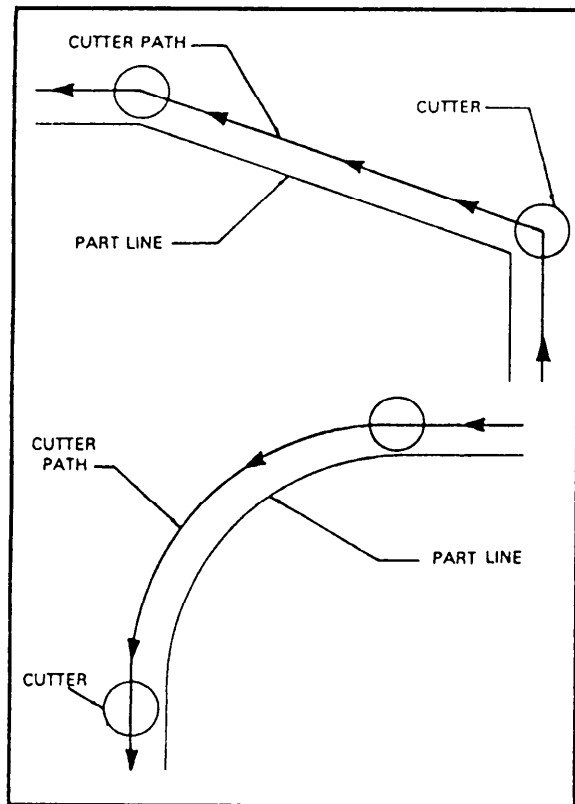


Figure 11-8.—Continuous-path angles and arcs.

angles, as shown in figure 11-8. Most newer NC machines are the continuous-path type.

## SERVOMECHANISMS

It will be helpful to understand the drive systems used on NC machinery. The drive motors on a particular machine will be one of four types: stepper motors, dc servos, ac servos, or hydraulic servos. Stepper motors move a set amount of rotation (a step) every time the motor receives an electrical pulse. DC and ac servos are widely used variable-speed motors found on small and medium continuous-path machines. Unlike a stepper motor, a servo does not move a set distance. When current is applied, the motor starts to turn: when the current is removed, the motor stops turning. The ac servo is a fairly recent development. It can develop more power than a dc servo and is commonly found in newer CNC machines. Hydraulic servos, like ac or dc servos, are variable-speed motors. Because they are hydraulic motors, they can produce much more power than an electric motor. They are used on large NC machinery, usually with an electric or pneumatic control system.

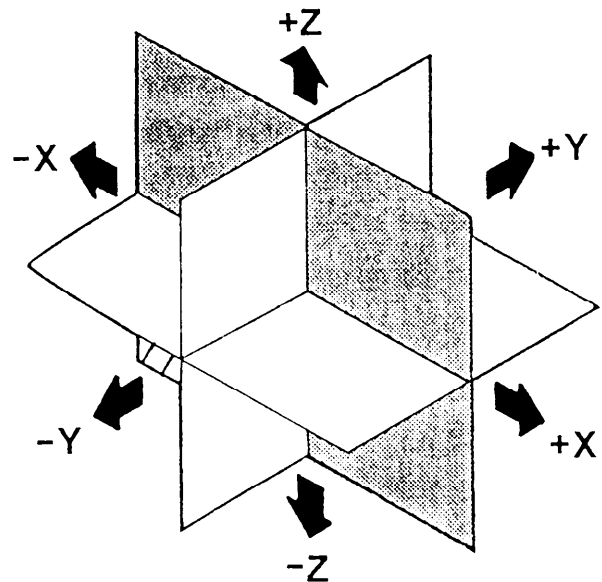


Figure 11-9.—Cartesian coordinate system.

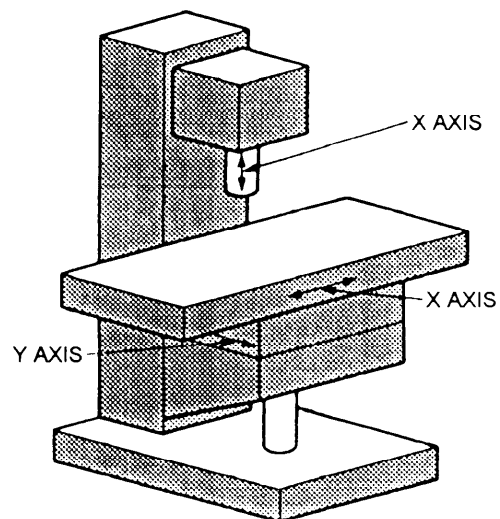


Figure 11-10.—Three-axis vertical mill.

## CARTESIAN COORDINATE SYSTEM

The basis for all machine movement is the Cartesian coordinate system (fig. 11-9). Programs in either inch or metric units specify the destination of a particular movement. With it, the axis of movement (X, Y, or Z) and the direction of movement (+ or -) can be identified. Some machining centers may have as many as five or six axes, but for our purposes we will only discuss three axes. To determine whether the movement is positive (+) or negative (-), the program is written as though the tool, rather than the work, is doing the moving.

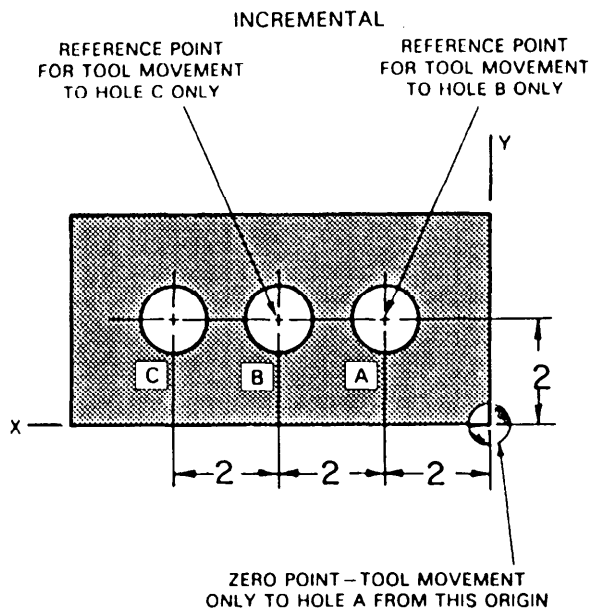


Figure 11-11.—Incremental positioning system.

Spindle motion is assigned the Z axis. This means that for a drill press or vertical milling machine the Z axis is vertical, as shown in figure 11-10. For machines such as lathes or horizontal milling machines, the Z axis is horizontal.

## POSITIONING SYSTEMS

There are two ways that machines position themselves with respect to their coordinate systems. These systems are called incremental positioning and absolute positioning. With incremental positioning (fig. 11-11) each tool movement is made with reference to the prior or last tool position. Absolute positioning (fig. 11-12) measures all tool movement from a fixed point, origin, or zero point. Use absolute dimensioning where possible because a mistake on the dimensions at one point will not be carried over to the dimensions at other points. It is also easier to check for errors.

### SETTING THE MACHINE ORIGIN

Most CNC machinery has a default coordinate system the machine assumes upon power-up, known as the machine coordinate system. The origin of this system is called the **machine origin** or **home zero**

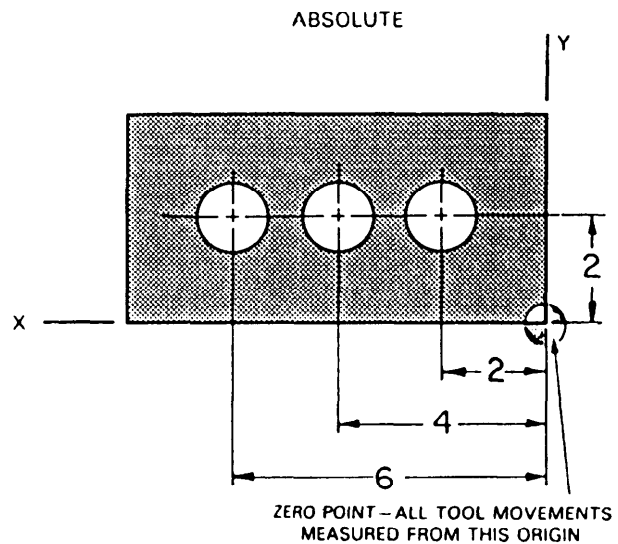


Figure 11-12.—Absolute positioning system.

location. Home zero is usually, but not always, located at the tool change position of a machining center. A part is programmed independent of the machine coordinate system. The programmer will pick a location on the part or fixture. This location becomes the origin of the coordinate system for that part. The programmer's coordinate system is called the local or part coordinate system. The machine coordinate system and the part coordinate system will almost never coincide. Before running the part program, the coordinate system must be transferred from the machine system to the part system. This is known as setting a zero point. In other words, the machine has a zero point that is already programmed into it, but you can place the part to be machined either in the chuck or on the table and establish your zero point, and then the machine will use that point as its zero point. This eliminates having to use fixtures and other complicated setups. You just put your work in the machine and by using the proper codes you tell the machine where the zero point is located.

As stated earlier in the chapter, this has only been a brief overview of CNC. It is a complicated subject that many books have been written about. To cover it completely you will need to have formal training and extensive on-the-job training. As the Navy expands into the world of CNC this training will become more readily available.

## CHAPTER 12

# METAL BUILDUP

### CHAPTER LEARNING OBJECTIVES

*Upon completing this chapter, you should be able to do the following:*

- *Explain the thermal spray system.*
- *Explain contact electroplating.*

Metal buildup is a rapid and effective method that can be used to apply almost any metal to a base material. It is used to restore worn mechanical equipment, to salvage mismachined or otherwise defective parts, and to protect metals against corrosion. Compared to original component replacement costs, metal buildup is a low-cost, high-quality method of restoration.

As you advance in the MR rating you must know how to prepare a surface for metal buildup and to set up and operate the equipment used in the thermal spray systems and the contact electroplating process. In this chapter, we will briefly discuss the thermal spray systems and contact electroplating. We will not cover the actual spraying or plating processes; you will learn them in classes you need to attend before you can be a qualified sprayer or plater.

Additional information on metalizing is in MIL-STD-1687A(SH), *Thermal Spray Processes for Naval Ship Machinery Applications*.

Additional information on electroplating is in MIL-STD-2197(SH), *Brush Electroplating on Marine Machinery*.

As with any shop equipment, you must observe all posted safety precautions. Review your equipment operators manual for safety precautions and any chapters of *Navy Occupational Safety and Health (NAVOSH) Program Manual for Forces Afloat*, OPNAV Instruction 5100.19B, that apply to the equipment. Also, read the sections in MIL-STD-1687A(SH) and MIL-STD-2197(SH) that cover safety.

### THERMAL SPRAY SYSTEMS

There are four different thermal spray processes: wire-oxygen-fuel spray, wire-consumable electrode spray, plasma-arc spray, and powder-oxygen-fuel

spray. All four generally perform the same basic function: they heat the wire or powder to its melting point, atomize the molten material with either high-velocity gas or air, and propel it onto a previously prepared surface. In this chapter we will discuss the wire-oxygen-fuel and powder-oxygen-fuel spray processes, with emphasis on the latter.

The rapid rate at which metal coatings can be sprayed and the portability of the equipment have increased the use of thermal spray processes. Metal coatings are especially useful to (1) rebuild worn shafts and other machine parts not subject to tensile stress, (2) apply hard surfacing that must resist wear and erosion, and (3) protect metal surfaces against heat and corrosion. Navy repair facilities use thermal spray processes to coat metallic and nonmetallic surfaces with practically any metal, metal alloy, ceramic, or cermet that can be made in wire or powder form. (Cermet is a strong alloy of a heat-resistant compound, a metal used especially on turbine blades.)

### APPLICATIONS

Thermal spray coatings have been approved by NAVSEA for several applications. Case-by-case approval is not needed for the following applications, but the procedures used for these applications are limited to those approved by NAVSEA:

- Repair of static fit areas to restore original dimensions, finish, and alignment
- Repair of seal (including packing areas) to restore original dimensions and finish
- Repair of fit areas on shafts to restore original dimensions and finish (except for motor generator sets)



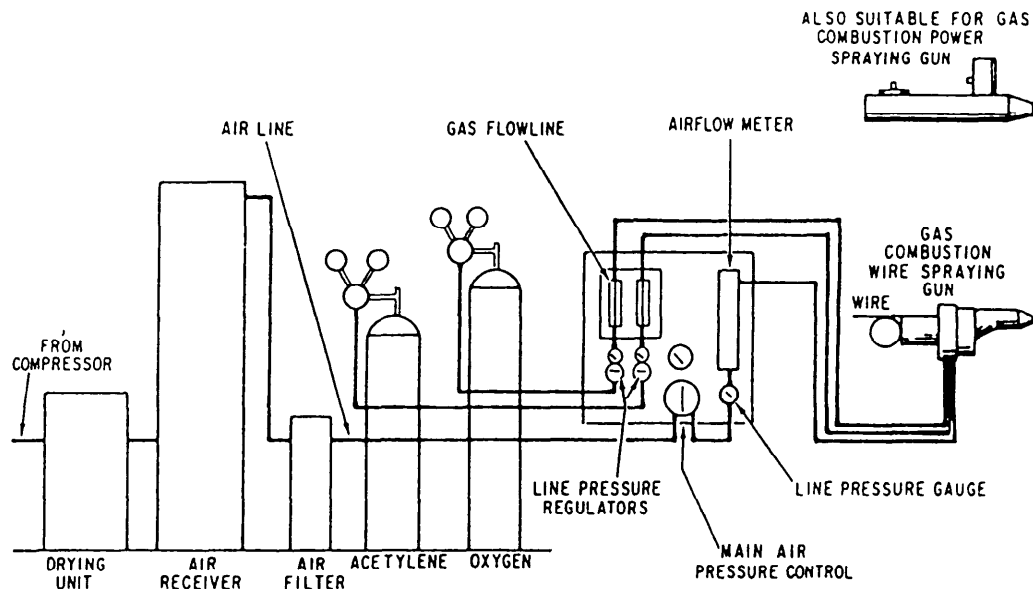


Figure 12-1.—Typical installation for combustion gas spraying.

- Buildup of pump shaft sleeves and wear rings to restore original dimensions
- Repair of bearing shaft journals to restore original dimensions
- Babbitt bearings for auxiliary equipment

Thermal spray is **NOT** approved for the following machinery applications on surface ships:

- Primary and secondary nuclear systems
- Main propulsion turbines
- Ships's service turbine generators
- Reduction gears
- Lineshafts and lineshaft bearings

**NOTE:** The thermal spray process is **NOT** authorized in the repair of submarine components (MIL-STD-1687A(SH)).

## QUALIFICATION OF PERSONNEL

Thermal spray operations are performed only by qualified personnel. Potential operators who pass the performance tests are certified to perform manual spraying, with the coating system and spray process used in the qualification testing. For each process, the operator must prepare test specimens for visual, microscopic, bend, and bond tests using qualified procedures developed for that particular coating and thermal spray process. In addition, the operator is

responsible for setting up the spraying equipment (gun-to-work distance, air, fuel gas, and so on) as required by the spraying procedure.

Certified operators retain their certification as long as they do not let 6 months or more time pass between their uses of the thermal spray process. Operators who let their certification lapse may requalify by satisfactorily completing the qualification tests. Complete information about certification is contained in MIL-STD-1687A(SH).

## TYPES OF THERMAL SPRAY

The two types of thermal spray discussed in this chapter are wire-oxygen-fuel spray and powder-oxygen-fuel spray.

### Wire-Oxygen-Fuel Spray

The wire-oxygen-fuel spray process is suitable for all-purpose use. It offers variable, controlled wire feed rate within the ranges required for all commonly used metalizing wires, and it can be used in both hand-held and machine-mounted applications. Figure 12-1 shows a typical installation.

The type 12E thermal spray gun (fig. 12-2) can spray metalizing wires such as aluminum, zinc, copper, Monel, nickel, and so forth. It can hold wire sizes ranging from 3/16 inch down to 20 gauge, and it can use acetylene, propane, natural gas, manufactured gas, or MPS as fuel. The wire is drawn through the gun and the nozzle by a pair of wire feed drive rollers, powered by

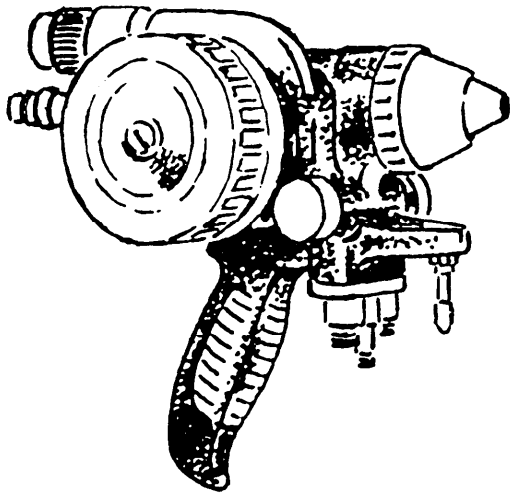
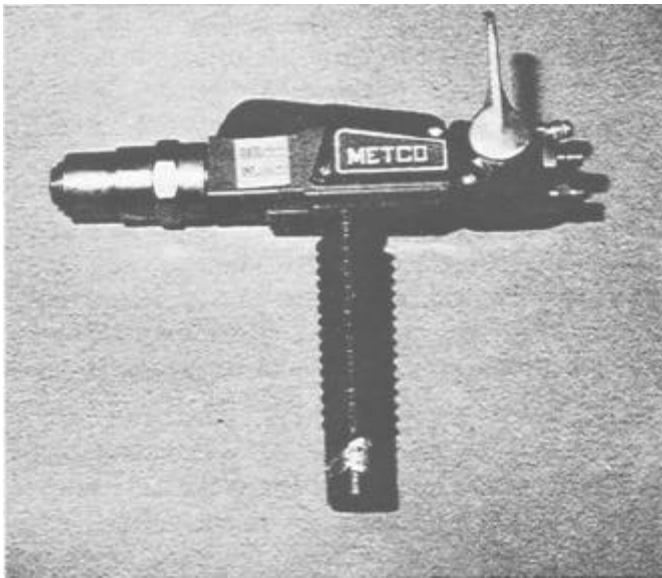


Figure 12-2.—Type 12E spray gun.



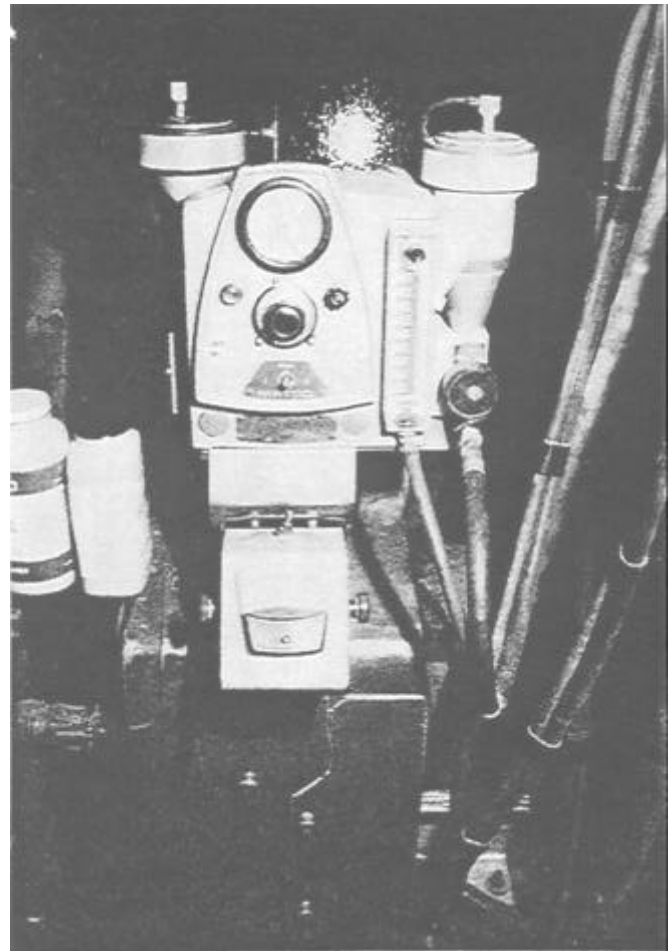
28.463

Figure 12-3.—Type 6P-II powder spray gun.

a self-contained compressed air turbine. At the nozzle, the wire is continually melted in an oxygen-fuel gas flame. Then, a controlled stream of compressed air blasts the molten tip of the wire, producing a fine metal spray. Systems of this type are commonly used to spray aluminum wire coatings for corrosion control on items such as steam valves, stanchions, exhaust manifolds, deck machinery, and equipment foundations.

### Powder-Oxygen-Fuel Spray

Figure 12-3 shows a type 6P-II powder spray gun. The powder is fed into the gun by a powder feed unit



28.464

Figure 12-4.—Power feed unit.

(fig. 12-4). The powder is propelled through the flame where it melts and is deposited on the work in the form of a coating. This gun will spray metal, ceramic, cement, and exothermic powders.

Exothermic coating composites are materials that produce an exothermic (heat evolved) reaction from their chemical creation. For example, when nickel and aluminum composites reach a certain temperature in the spray gun flame, they combine to produce nickel aluminite and heat. The extra heat provided to the molten particles by the exothermic reaction, coupled with the high particle velocity of the thermal spray process, accounts for the self-bonding characteristics of the coating and its exceptional strength.

Exothermic materials are often called one-step coatings. They produce self-bonding, one-step buildup coatings that combine metallurgical bonding with good wear resistance. They also eliminate the need for separate bond and buildup coatings.

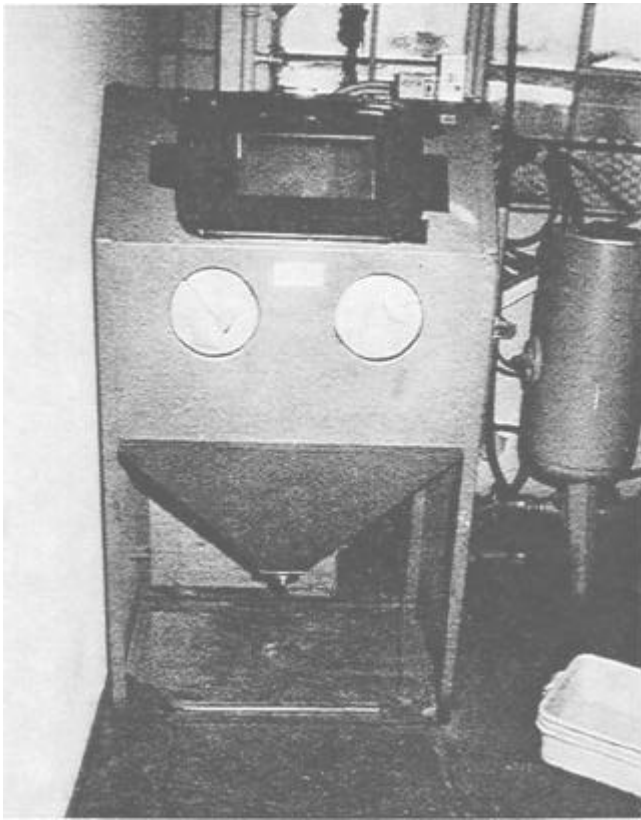


Figure 12-5.—A typical sandblaster. 28.465

## PREPARING THE SURFACES

Surface preparation is often the most critical part of the job, yet it often gets the least attention. We cannot overemphasize its importance because an improperly prepared surface will cause the part to fail under operating conditions. For this reason, even the best and most elaborate preparation is still the cheapest part of the job. Quite often, surfaces are not prepared properly

because it is inconvenient or the necessary equipment is not available. To help ensure a quality job, be sure you use the required equipment and prepare the surface carefully and thoroughly.

Surface preparation includes three distinct operations: (1) cleaning, (2) undercutting, and (3) surface roughening. We will discuss each of them in the next paragraphs.

### Cleaning

You must ensure a good bond between the sprayed coating and the base material to which it is applied. To do that, be sure the areas to be coated and the adjacent areas are free from oil, grease, water, paint, and other foreign matter that may contaminate the coating.

**SOLVENT CLEANING.**—Before blasting or spraying, use solvent to clean all surfaces that have come in contact with any oil or grease. (Vapor degreasing is preferred, but you may use solvent washing.) When using solvent, be very careful that it is not strong enough to attack the base material; do NOT leave any residue on the surfaces. Trichloroethane and toluene are suitable solvents. Most solvents are flammable and toxic, so you must follow proper precautions when you use them. You also must be very careful to protect any parts that may be attacked by the solvents.

**ABRASIVE CLEANING.**—You can use a sand blaster such as the one shown in figure 12-5 to remove heavy or insoluble deposits. Be sure to follow your operator's manual. Do not use the same abrasive blasting equipment to roughen surfaces that you use for general cleaning.

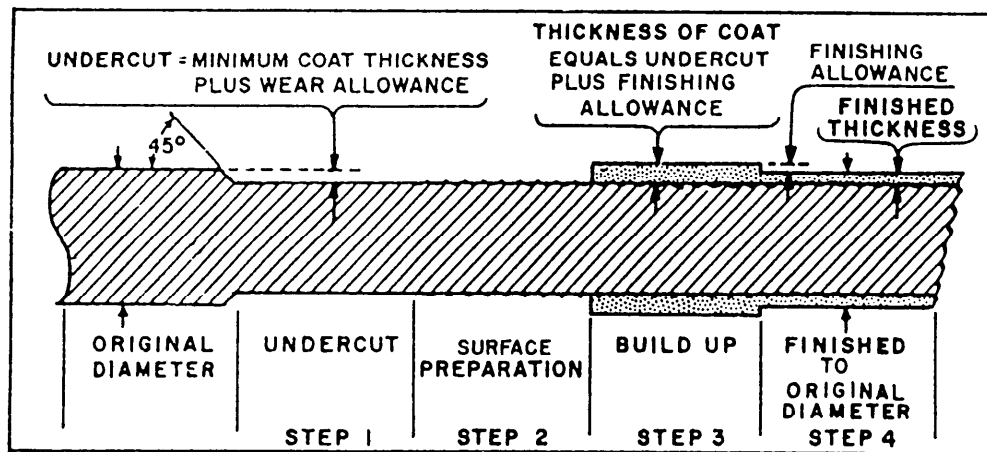


Figure 12-6.—Major steps in restoration of dimensions with thermal spray.

**HEAT CLEANING.**—Use a solvent to clean porous materials that have been contaminated with grease or oil. Then, heat them for 4 hours to char and drive out foreign materials from the pores. Heat steel alloys at 650°F maximum; heat aluminum alloys at 300°F maximum. Do not heat age-hardening alloys. In thin sections, use lower temperatures to minimize warpage.

### Undercutting

In undercutting, you remove enough of the surface of the metal to be built up to ensure a satisfactory thickness of metalized deposit on the finished job. (See fig. 12-6.) Undercutting must be a dry machining operation; any cutting lubricants or coolants used will contaminate the surface of the workpiece. When you build up shafts, be sure the undercut section is concentric to the original axis of the shaft. The length of the undercut should extend beyond both ends of the sleeve or bearing, the limits of the carbon or labyrinth ring, or the packing gland in which the shaft will operate. However, you must be careful not to remove any fillets at points where the shaft section diameter changes. The ends of the undercut should be at 15 to 45 degrees to the base metal.

Several factors determine the depth to which you should undercut a shaft. Some of them are severity of service, the amount of wear expected in service, the depth of metal loss, the remaining thickness of the load-carrying member, and the limits of the coating you will use. In general, the minimum specified depth of the undercut should be at least equal to the recommended minimum thickness of the coating, plus the wear or corrosion tolerance for the application.

Undercutting reduces the effective structural cross section of the part to be metalized. Also, sharp grooves and shoulders without a fillet or radius may produce stress risers. A stress riser is a spot on a part where stresses have been set up that may cause the part to fail.

When you prepare for thermal spraying, carefully examine the workpiece from a design standpoint. Consider all parts that will be subjected to high stresses, shock loads, or critical applications to be sure the structure maintains adequate strength. You cannot depend upon metal spray deposits to restore qualities such as tensile strength or resistance to fatigue stress.

### Surface Roughening

After undercutting the shaft, you must roughen the undercut section to provide a bond for the metal spray.

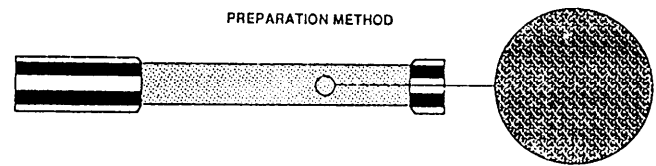


Figure 12-7.—A 2- to 3-mil anchor-tooth profile.

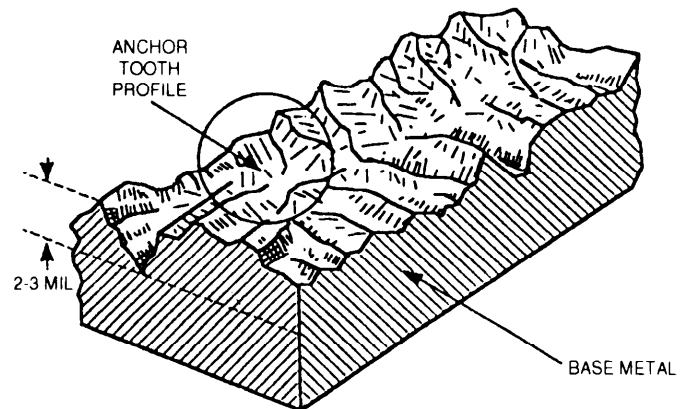


Figure 12-8.—Profile of an anchor-tooth pattern.

Do NOT use a lubricant or coolant during the undercutting and roughening process. Keep the surface clean and dry; you can contaminate it if you touch it with your hands. If the surface becomes contaminated, you must thoroughly clean and degrease it. The cleanliness and roughness greatly affect the strength of the bond between the base metal and the sprayed coating. Two methods of surface roughening are (1) abrasive blasting and (2) macroroughening. Use the latter method to restore dimensions greater than 1/2 inch where you cannot use exothermic materials.

**ABRASIVE BLASTING.**—Before thermal spraying, use abrasive blasting to condition the surfaces to be coated. Blasting must not be so severe as to distort the part. The required depth of surface roughness is related to the configuration (size and shape) of the part. Where part configuration permits, use a roughness profile of 2 to 3 mils (as shown in figs. 12-7 and 12-8). When this depth may cause distortion because of the part configuration, you can reduce the anchor-tooth pattern to a 1-mil profile.

The blasting particles recommended for surface preparation are angular nonmetallic grit (for example, aluminum oxide) and the recommended mesh size is 16. When a grit is designated for surface preparation, it must remain clean, so do not use it for any other purpose.

Clean, dry air is essential for proper blasting. Traces of oil in the air that cannot be readily detected can seriously affect the bond.

Before reuse, screen the aluminum oxide grit using a 30-mesh screen, and visually inspect it for debris and oil contamination according to MIL-STD-1687A(SH).

Cover and mask all areas of a component that will not be grit blasted to prevent damage or contamination by the abrasive blasting medium and debris. Grit rebounding from the walls of the blast room or blast cabinet may scratch and damage those uncovered areas. Masking may be an expensive part of the operation and you should consider cost when you select the masking method. When you finish blasting, remove any masking material that is unsuitable as masking for the thermal spray process and replace it with suitable material. We will discuss this in later paragraphs.

Rubber or aluminum masking tape is satisfactory for all operations where you can do hand masking economically. Since rubber is not cut by the blasting operation, you can use it almost indefinitely. You can use thin rubber tape for heavy blasting protection.

**MACROROUGHENING.**—Macroroughening is a lathe operation performed on bearing areas of shafts or similar surfaces. It consists of cutting a narrow, low-pitch, shallow groove or thread in the surface.

## **APPLYING THE COATING**

You will apply the coating by using three distinct procedures: (1) mask the component, (2) spray the coating, and (3) apply a sealant to the coating. We will discuss each in the next paragraphs.

### **Masking for Spraying**

You can use tape, liquid masking compounds, silicon rubber, or metal shielding as thermal-spray masking materials. Tape must be designed for high-temperature use. Masking materials must not cause corrosion or contamination of the sprayed coatings. Generally, you will mask materials to be sprayed with masking tape and masking compound. Use a pressure-sensitive masking tape designed to withstand the usual spray temperatures.

Use masking compound where a liquid masking material is more convenient. It is a water-soluble material that can be brushed onto any surface to prevent the adhesion of sprayed material. Approved masking compound will not run or bleed at the edges.

You also may use masking compound to protect the spray booths and other equipment that is subject to overspray, such as rotating spindles, chucks, lathes, and the like. When you use masking compound for this purpose, be sure you clean the surfaces on a regular schedule and reapply the compound. If you don't, it will eventually dry out and the sprayed material will then stick to the substrate.

In situations where you cannot protect holes, slots, keyways, or other types of recesses with tapes or shields, use inserts of carbon, metal, or rubber. Install them before you begin abrasive blasting and spraying, and leave them in place throughout the thermal spray operation. Remove them after you complete the surface finishing but before you apply the final sealer.

### **Spraying the Coating**

Spray the component using the specifications you will find in the approved procedure for the material being sprayed. These specifications cover gun-to-work distance, rotational or linear speed of the gun to the workpiece, air, fuel, gas, primary and secondary pressures, and power output. Figure 12-9 shows a shaft being thermal sprayed.

### **Applying the Sealant**

Sprayed coatings must be treated with a sealant to prevent corrosive attack or fluid leakage. Select the sealant on the basis of the maximum use temperature of the component and the purpose of sealing the coatings. Apply the sealant after spraying and before finish machining.

## **SURFACE FINISHING**

Use surface finishing to reduce the component to its specified dimensions and to provide a finer surface finish than the sprayed finish. Remove all masking materials before you finish a surface. The acquisition specification or drawing will dictate the finished dimensions.

Coatings may be used in the as-sprayed condition whenever permitted. The type, hardness, and thickness of the coating determines the finishing method. You will often finish softer coating materials by machining. You can get a good machine finish in most applications by using high speed and carbide tools. Generally, you will grind harder coating materials to get the best finish.

Take care in any machining or grinding operation to avoid damage to the coating. Improper machining



**Figure 12-9.—A shaft being thermal sprayed.**

**28.466**

techniques can pull out particles, producing a severely pitted surface or heat checking. It is essential that the sprayed particles be cleanly sheared and not pulled from the surface by the finishing operation.

Generally, wet grinding is better than dry grinding if you use the proper wheel. Use wheels with coarse grain and low bond strength to grind sprayed coatings; this prevents loading the wheel. When you use a coolant, try to get one with a rust inhibitor and keep it clean and free of foreign matter.

Always consult and follow the coating manufacturer's finishing recommendations when you select the finishing technique, including the proper tool, feeds, and speeds.

## **QUALITY ASSURANCE**

In-process inspection of each sprayed component shall assure, as a minimum, verification of the anchor-tooth prepared surface with a profile tape test; no moisture, oil, grit, contaminants, blisters, cracks, chips, pits, or coating separation are present before or during spraying; coating thickness per pass conforms to the procedure, if this is an essential element; and the coating manufacturer's recommended temperature range is maintained.

As a minimum, the end item inspection of sprayed coating will include a visual examination. The finished coating, when examined with a 10X magnification, will

be free of defects such as cracks, chips, blisters or loosely adhering particles, oil or other contaminants that bleed out through the coating, pits exposing the undercoat or substrate, and coating separation. The item will be checked for correct dimensions.

## **CONTACT ELECTROPLATING**

Contact (brush-on) electroplating is also called contact plating. It is a method used to deposit metal from concentrated electrolyte solutions without the use of immersion tanks. The solution is held in an absorbent material attached to the anode lead of a dc power pack. The cathode lead of the power pack is connected to the workpiece to provide the ground and complete the plating circuit. Electroplating deposits metal when the absorbent material on the anode contacts the work area. Constant motion between the anode and the work is required to produce high-quality, uniform deposits.

Contact electroplating can be used effectively on small to medium size areas to perform the same functions as bath plating. Some examples are corrosion protection, wear resistance, lower electrical contact resistance, and repair of worn or damaged machine parts. This process is not recommended to replace bath plating. However, electroplating is superior to bath plating in some situations, most of which are in the following list:

- The equipment is portable; plating can often be done at the job site.

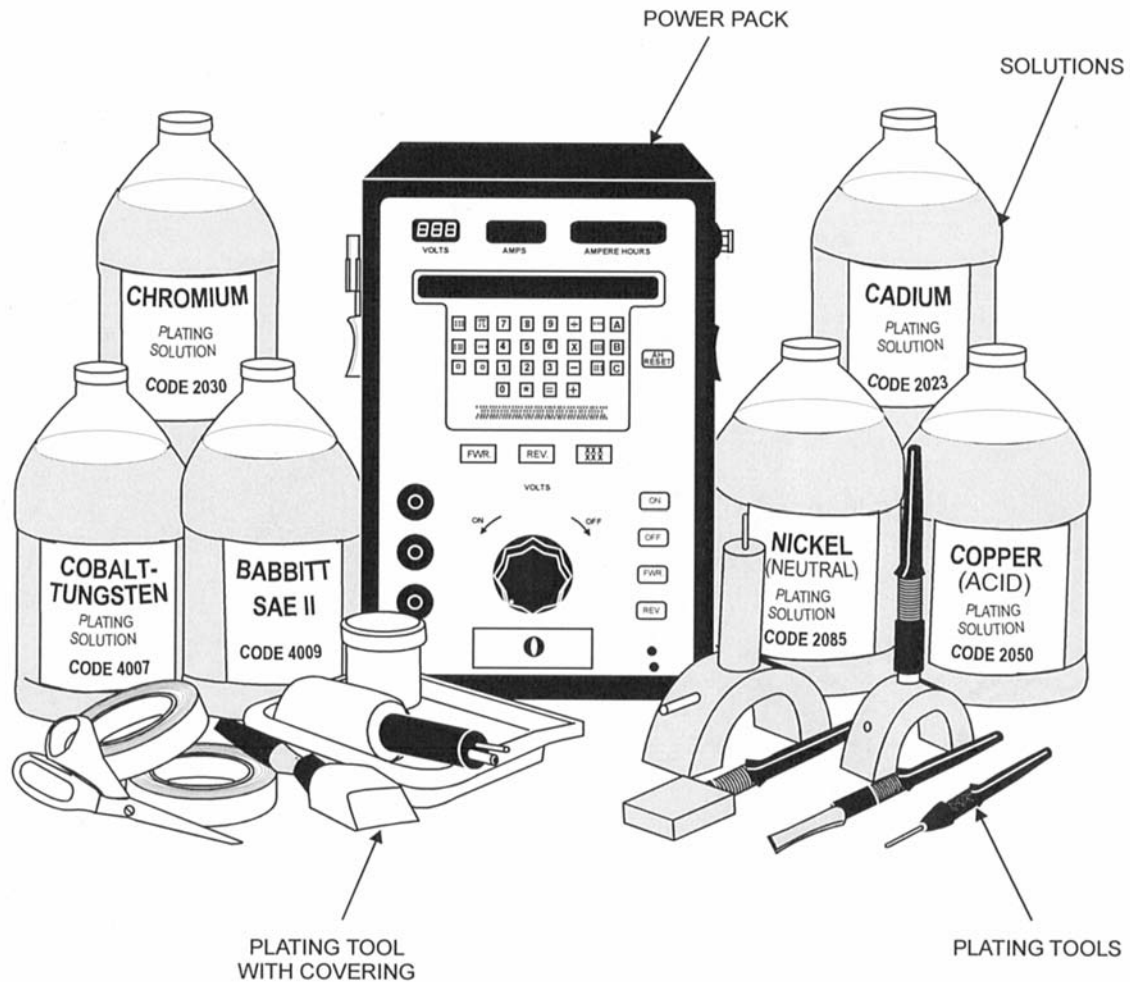


Figure 12-10.—Electroplating equipment.

- It can reduce the amount of masking and disassembly required.
- It permits plating of small areas of large assembled components or parts too large for available plating tanks.
- By plating to the required thickness, it can often eliminate finish machining or grinding of the plated surface.
- Damaged or defective areas of existing plating can be touched up instead of complete stripping and replating of the entire part.

## ELECTROPLATING EQUIPMENT

We will discuss contact electroplating equipment in the following paragraphs. These are the power pack,

plating tools, solutions, and plating tool coverings, and they are shown in figure 12-10. We will cover them briefly because your plating machine operators manual covers them in depth.

### Power Pack

Contact plating power packs are available in the following dc output ranges: 0 to 15 amperes at 0 to 20 volts and 0 to 150 amperes at 0 to 40 volts. They operate on 115- or 230-volt, 60-Hz, single- or three-phase ac input.

The intermediate sizes, 25 to 100 ampere maximum output, are the most common. They are portable, weighing less than 150 lbs, yet can provide the required power for most shipboard and shop work. A unit in the 60- to 100-ampere range is recommended as basic

contact plating shop equipment. It will remain useful even if changes in the workload require smaller or larger units to supplement it.

## Plating Tools

Contact plating tools consist of a stylus handle with a conductive core, which is insulated for operator safety, and an insoluble anode normally of high-quality graphite. Since considerable heat is generated during plating operations, there must be a means of cooling the plating tool. The handles of plating tools have cooling fins to dissipate heat, but you may need to cool larger tools with plating solution or water. Graphite anodes are brittle and are not practical where a very small diameter anode is required. For plating holes less than 1/2 inch in diameter, or narrow slots and keyways, anodes made of 90 percent platinum and 10 percent iridium material are recommended.

The equipment manufacturers offer removable anodes in a wide range of standard sizes and in three basic shapes: cylindrical or convex to plate inside diameters, concave for outside diameter's, and flat or spatula shaped. You also may purchase graphite material to manufacture special tools.

## Solutions

The solutions used in contact plating include preparatory solutions used to clean and activate the surface to be plated, plating solutions used to deposit pure or alloy metals, and stripping solutions used to remove defective plating. These solutions are manufactured and sold by the process equipment manufacturers. You can use solutions of any trade name if the deposits meet the applicable plating specification and if they are certified by procedure tests. However, do NOT use plating and preparatory solutions of different manufacturers for the same plating job.

For plating operations, pour solution into a shallow glass or plastic dishes or beakers for dipping, or use them in a pump that dispenses solution through the tool.

## Plating Tool Coverings

The most common tool covering is cotton batting of surgical grade U.S.P. long fiber, sterile cotton. It is fastened to the anode to hold and distribute the solution uniformly. You can use cotton batting alone for jobs that involve a few short preparing and plating operations, or to ensure maximum tool to workpiece contact for plating in corners or on irregularly shaped areas. When

you need longer tool cover life, place cotton, Dacron, or cotton-Dacron tubegauze sleeving over the cotton batting. You also may use Dacron batting, Pellon, and treated Scotchbrite to cover plating tools.

## APPLICATIONS

The contact plating process is a rapidly expanding field. When used to deposit a corrosion-resistant coating, electroplating has shown enough success to permit almost unrestricted use. The vast field of possible applications in the repair of worn or damaged parts of high-speed rotating and reciprocating machinery is limited only by the knowledge and skills of the operator in areas where plating is allowed. Electroplating applications are classified as follows:

- Class 1: Plating used for decorative or corrosion prevention functions only
- Class 2: Plating on parts to restore dimensions on surfaces that remain in static contact with gaskets, O-rings, or other metal surfaces
- Class 3: Plating on parts that make rubbing or intermittent contact with other plated or unplated parts, including electrical contacts except those in class 3A
- Class 3A: Plating on rubbing contact surfaces of turbines, reduction gears, electric power generating units, main propulsion shaft seals, steam valves, and other sliding contact areas when specified
- Class 4: Plating on parts under the cognizance of the Nuclear Propulsion Directorate

Refer to MIL-STD-2197(SH) for plating applications for each of these classes.

## OPERATOR QUALIFICATION

Operators will be qualified by the quality assurance function of the plating activity before being permitted to perform contact electroplating.

Before examination for qualification, each prospective operator will successfully complete a manufacturer-sponsored training course or one provided by the plating activity. The course shall be approved by the



quality assurance function of the plating activity and will as a minimum prepare the prospective operator to demonstrate a knowledge of the following:

- The technical aspects of brush electroplating
- Job safety for hazardous chemicals and electrical work
- The calculation of plating amperage, plating time, quantity of solution required, surface area, and ampere-hours
- The meaning of the terms *current density, activation, anode, cathode, adhesion, burned deposits, modulus, porosity stripping, etch, waterbreak, matte finish, volts, and amperes.*
- Setup and operation of a power supply
- Preparation of metal surface for brush electroplating
- Selection, preparation of, and postuse care of the plating tools (anodes) and covers
- The attributes used to control plating thickness time and quality
- Prevention of contamination of plating solutions
- Proper masking technique
- Proper plating technique
- Proper surface finishing technique
- Evaluation of the deposit's adhesion, thickness, and visual appearance
- Preparation of job records

An operator will have passed a written examination covering these subjects. The examination will be administered either by the training activity or the plating activity, and approved by the quality assurance function of the plating activity.

The operator will demonstrate to the quality assurance function of the plating activity that he or she is capable of performing brush electroplating by plating test specimens following MIL-STD-2197(SH) specifications.

Requalification is required when the operator has not performed any production work for which he or she is qualified for a period of 12 months or more, or when

the quality assurance function of the plating activity has reason to question the ability of the operator to produce quality plating.

## **PLATING PROCEDURES**

Brush electroplating will be performed to an approved written procedure. The procedure will contain as a minimum the following:

- A unique identifying number
- Date of approval
- Authorizing signature
- Applicable plating thickness
- Plating treatment's, such as stress relief or peening, if required
- Required operators qualification
- Preliminary cleaning
- Electrocleaning and etching
- Rinsing
- Activating
- Plating solutions, preplate (if needed), current density, and anode to cathode speed
- Drying
- Postplate treatments, such as blasting or grinding, if required
- Records
- Inspection requirements and acceptance criteria

In addition to MIL-STD-2197(SH) and MIL-STD-865, commercial manuals provided by brush electroplating solution and equipment contractors form the basis for information pertaining to brush electroplating.

## **QUALITY ASSURANCE**

The quality assurance function of the plating activity shall enforce the requirements of M-STD-2197(SH). The tests will include visual inspection, adhesion test, thickness of deposit, and dye penetrant inspection for classes 3 and 3A applications only.

## CHAPTER 13

# REPAIR WORK

### CHAPTER LEARNING OBJECTIVES

*Upon completing this chapter, you should be able to do the following:*

- *Explain the removal of broken studs and taps.*
- *Describe the repair and inspection of pumps.*
- *Explain the procedure used to straighten shafts.*
- *Describe the inspection of constant-pressure governors.*
- *Explain the uses of in-place machining equipment.*
- *Explain the purpose of METCAL.*
- *Explain the purpose of the quality assurance program.*
- *Explain the purpose of the planned maintenance system.*

In this chapter we'll discuss some of the different jobs you may encounter as an MR. We'll also discuss some of the things you need to know before you start the job, such as quality assurance, calibration, and planning.

### JOB PREPARATION

There are a number of things you must do before you actually start a job in a machine shop. If you ignore these things, the job may turn out to be inaccurate. Even worse, it may be perfect but still not useable because of improper documentation. We'll now discuss some of the things you must do to prepare for the job.

As with any shop equipment you must observe all posted safety precautions. Review your equipment operators manual for safety precautions. Also read any chapters of *Navy Occupational Safety and Health (NAVOSH) Program Manual for Forces Afloat*, OPNAV Instruction 5100.19B, that apply to the equipment.

### CALIBRATION

Calibration assures us that the parts we manufacture will fit together as they should. The increased complexity of ship systems has made it necessary to improve the accuracy of measurements. The Navy addressed this problem by creating the Navy Metrology and Calibration (**METCAL**) Program. This program ensures the traceability and accuracy of instrument calibration. To operating personnel, this means that any instrument used for quantitative measurement must be calibrated.

Simply stated, you must always be sure the instruments you use for quantitative measurement are calibrated. Never use an instrument with an outdated calibration sticker. If you suspect a measuring instrument has been damaged, be sure it is taken out of use and calibrated. For more information on the **METCAL** program refer to *Instrumentman 3 & 2*, NAVEDTRA 10193-D.

### QUALITY ASSURANCE

The philosophy of quality assurance (QA) is unique in that it does not recognize degrees of success. QA is

pass-fail. In our educational system, a student who answers 99 percent of the questions correctly will get straight A's. By contrast, an MR may manufacture 99 percent of a part perfectly, but the part ends up in the scrap bin because of the 1 percent done improperly. The part must be redone and the costs are additional time, effort, money, and embarrassment to the machinist.

Quality assurance is used to lay out procedures in which we assemble and disassemble components and repair their parts. All MRs must be familiar with QA since it is something they will use every day on the job. Refer to your type commander's quality assurance manual, which is developed according to SECNAVINST 4855.1, for information on the quality assurance program. *Engineering Administration*, NAVEDTRA 12147, also contains a chapter on QA that is condensed and easily understood.

## PLANNED MAINTENANCE SYSTEM

Maintenance is one of the most important jobs you will do in the Navy. The degree of accuracy to which you can machine a part is often directly related to the condition of the machine tools you are using. If preventive maintenance is not done properly, or not done at all, your equipment may be put out of commission until it can be repaired.

Preventive maintenance includes actions to prevent equipment from failing, such as taking oil samples, changing the oil, greasing, cleaning or replacing filters, or simply cleaning each machine before and after its use.

Information on the planned maintenance system is found in *Ships' Maintenance and Material Management (3-M) Manual*, OPNAVINST 4790.4.

## PLANNING WORK

Occasionally you may be fortunate enough to have a TRS (technical repair standard) to give you step-by-step instructions for a job. Unfortunately there are very few TRSs for machine shop work. You normally have to plan the steps for each job.

To start with, you will need to research technical publications or blueprints for job specifications. If a job is as-per-sample, you may need to draw your own blueprint. Decide which machines are required to make the part and calculate all necessary dimensions. Choose the most logical sequence of machining operations so that the part is machined in a minimum of setups. Be sure the correct material is on hand for the job.

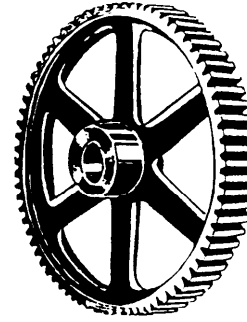


Figure 13-1.—Part made in a machine shop.

Once you have the job planned, be sure all documentation is properly recorded from the start of the job until the finish.

## REPAIR JOBS

The Navy supply system usually provides replacement parts for most equipment, but occasionally you will need to make parts such as shafts and gears. (See fig. 13-1).

A major portion of the repair work done in shipboard machine shops involves machining worn or damaged parts so that they can be placed back in service. For example, you will machine the sealing surfaces of leaking valves and pumps, remove broken studs, and repair bent or damaged shafts. Repair work is usually more difficult than manufacturing work because of alignment problems in the machining operation.

## SHAFTS

If you work in a machine shop, some of your common jobs will be to manufacture, straighten, and stub shafts. We will discuss them in the following paragraphs.

### Manufacturing a New Shaft

In figure 13-2, the circled numbers show a sequence of operations by which a shaft might be made in a machine shop. The manufacturer's technical manual for the equipment that contains the shaft will normally have this information. Look at figure 13-2 as you read the following material.

Select and cut a piece of round stock at least 1/16 inch larger in diameter and 1/8 inch longer than the shaft. Face and center drill each end of the stock. In

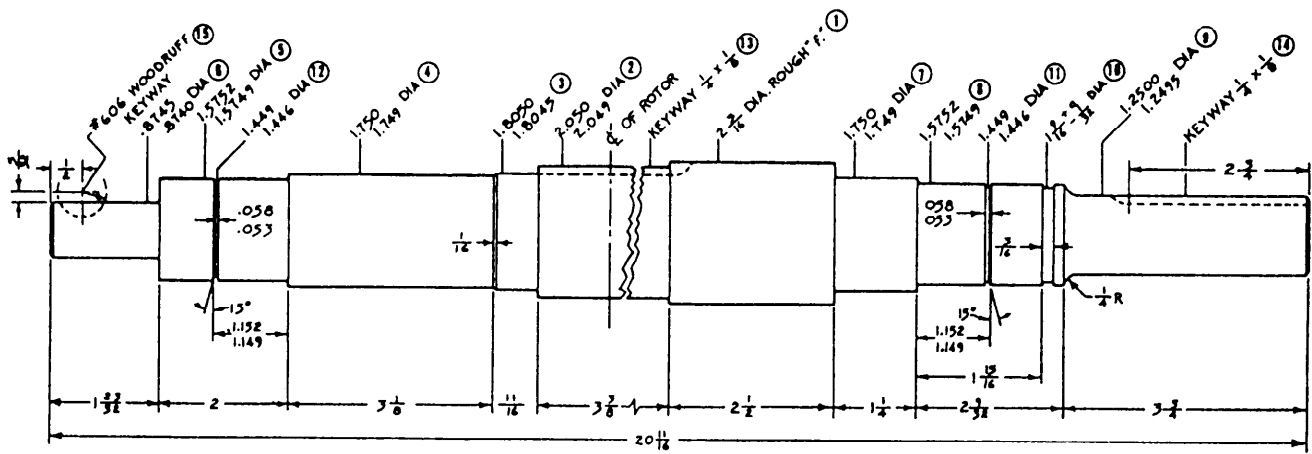


Figure 13-2.—Steps in making a shaft.

facing, be sure you face the workpiece to the correct length for the shaft, which in this example is 20 11/16 inches. Most of the linear dimensions in figure 13-2 are given in the form of mixed numbers of proper fractions; this indicates that you can use a rule to measure the dimensions. However, the linear position of the grooves at numbers 11 and 12 are in decimal fractions; you must measure these with an instrument more accurate than a rule. When you manufacture a new shaft, you must take all linear dimensions from the same reference point to ensure the correct lengths.

You can machine this particular shaft in two lathe setups and two mill setups. In the first lathe setup, do the plain turning required on surfaces 1 through 6; then machine surfaces 7 through 12 in the second lathe setup. Machine keyways 13 and 14 in the first milling setup; and then change the cutter to machine the Woodruff keyway (15). To machine the shaft, take the following steps:

1. Turn the workpiece to a 2 3/16-inch diameter. Check the diameter for taper and make corrections as necessary.

2. Set hermaphrodite calipers to 11 3/32 inches and lay out the shoulder between the 2 3/16 inch diameter and the 2.050 inch finish diameter. Using the crossfeed handwheel with the micrometer collar set on zero, feed the tool in 0.068 inch (one-half of the difference between 2.050 and 2 3/16). Make a short length of cut at the end of the shaft and measure the diameter with a micrometer. Adjust the crossfeed handwheel as required to provide the 2.050 + 0.000 - 0.001 diameter and complete the cut to the layout line.

3. Use procedures similar to those described in step 2 to machine surfaces 3 through 6. Be extremely careful to accurately measure the diameter of the beginning of each cut to ensure that you hold the dimensions within the range provided in the illustration.

4. Turn the workpiece end-for-end and machine surfaces 7, 8, and 9 as described in step 2.

5. Set a 3/16-inch parting tool in the toolholder, position the tool (by rule measurement) to make groove 10, and make the groove.

6. Set the compound rest parallel to the axis of the workpiece to lay out grooves 11 and 12. Place a sharp pointed tool in the toolholder and align the point of the tool with the shoulder between surfaces 7 and 8. Then use the compound rest to move the tool 1.152 inches longitudinally as indicated by the micrometer collar on the compound feed screw. Feed the tool toward the work with the crossfeed until a thin line is scribed on the surface of the workpiece. Now swivel the compound rest to the angle required to cut the chamfer, and cut the chamfer. (Calculate the angular depth from the given dimensions.) Then use a parting tool between 0.053 and 0.058 inch wide to make the groove.

7. With a fine cut file, remove all sharp edges from shoulders and grooves.

8. Remove the shaft from the lathe, mount it in the milling machine, and mill the keyways to the required dimensions.

### Straightening a Shaft

In many cases, bent shafts can be straightened so they have less than 0.001 inch runout. Before you try to

straighten a shaft, however, always be sure the leading petty officer of the shop is informed of the operation. Use the following steps to straighten a shaft:

1. Mount the shaft between centers in a lathe. If the shaft is too long, mount it on rollers.

2. Clamp a dial indicator on the compound rest, locate the area of the bend, and measure how much the shaft is bent (runout). To determine the area of the bend, run the dial indicator along the shaft longitudinally. The greatest variation of the pointer from zero indicates the bend area. With the dial indicator set at this point, rotate the shaft and note the amount of fluctuation of the pointer. This fluctuation is the amount of runout. Mark the longitudinal position of the bend and the high side of the bend with chalk or a grease pencil.

3. Remove the shaft from the lathe and place it on a hydraulic press. Place a V-block on each side of the bend area and turn the shaft so the high side is up. Move the press ram downward until it touches the shaft. Set up a dial indicator so that the contact point contacts the high side of the shaft as near to the ram as possible.

4. Carefully apply pressure on the shaft with the ram. Watch the pointer of the dial indicator to determine how much the shaft is “sprung” in the direction opposite the bend. When the indicator reading is 0.002 or 0.003 inch greater than the amount of runout, release the ram pressure.

5. Set up the shaft between centers and check again as explained in step 1. Repeat steps 2, 3, and 4 until the runout is decreased to within acceptable limits.

If the first attempt produces little or no change in runout, spring the shaft further in the second operation to overcome the elasticity of the shaft so that it bends in the required direction. It’s better to make several tries and gain a few thousandths of an inch at a time than to do it in one or two tries and perhaps bend the shaft too far in the opposite direction.

### **Stubbing a Shaft**

You can repair the damaged ends of shafts by removing the bad section and replacing it with a new “stub” end. Always check to see if your type commander allows stubbing of shafts. Use the following steps to stub a shaft:

1. If a blueprint is not available, make a drawing of the shaft showing all dimensions.

2. Begin with a piece of scrap stock (spud) of the same material as the shaft. Use a lathe to machine it to

the diameter of the shaft at the point where the center rest will be used. Carefully align the center rest on this spud.

3. Mount the undamaged end of the shaft in a 4-jaw chuck and “zero in” the shaft near the jaws of the chuck. Use soft jaws or aluminum shims to prevent damage to the shaft surface.

4. Position the previously set center rest under the shaft so the center rest is between the chuck and the damaged end of the shaft.

5. Cut off the damaged portion of the shaft.

6. Face, center drill, and drill the end of the shaft. The diameter of the hole should be about 5/8 of the diameter of the shaft; the depth of the hole should be at least 1/2 times the hole diameter.

7. Chamfer the end of the shaft liberally to allow space for weld deposits.

8. Make a stub of the same material as the shaft. The stub should be 1/4 inch larger in diameter and 3/8 inch longer than the damaged portion of the shaft plus the depth of the hole drilled in the shaft. This provides ample machining allowance.

9. Machine one end of the stub to a press fit diameter of the hole in the shaft. The length of this portion should be slightly less than the depth of the hole in the shaft. (A screw fit between the shaft and stub can be used instead of the press fit.)

10. Chamfer the shoulder of the machined end of the stub the same amount as the shaft is chamfered.

11. Press (or screw for a threaded fitting) the stub into the shaft and have the chamfered joint welded and stress relieved.

12. Mount the shaft with the welded stub back in the lathe, and machine the stub to the original shaft dimensions provided by the drawing or blueprint.

### **REPAIRING VALVES**

To repair valves, you must have a knowledge of the materials from which they are made. Each material has its limitations of pressure and temperature; therefore, the materials used in each type of valve depend upon the temperatures and pressures of the fluids that they control.

Valves are usually made of bronze, brass, cast or malleable iron, or steel. Steel valves are either cast or forged and are made of either plain steel or alloy steel.

Alloy steel valves are used in high-pressure, high-temperature systems; the disks and seats of these valves are usually surfaced with a chromium-cobalt alloy known as Stellite. This material is extremely hard.

You will find information on the commonly used types of valves and their construction in *Fireman, NAVEDTRA 12001*. The information in the following sections applies to globe, ball, and gate valves, but the procedures can usually be adapted to repair any type of valve.

## Repairing Globe Valves

Begin with an inspection of all parts of the valve for wear and alignment and, if you find them defective, repair or renew them. However, most valve repair is limited to overhaul of the seat and disk, and we will concentrate on those procedures.

Make a close inspection of the valve seat and disk. Look for erosion, cuts on the seating area, and proper fit of the disk to its seat. In a normal overhaul, you will grind-in the seat and disk, or lap the seat and machine the disk in a lathe. When the parts are in such bad condition that the normal procedure will not work, you must machine both the valve disk and valve seat in a lathe. If the disk and seat appear to be in good condition, use the spotting-in procedure described in the next paragraphs to be sure.

**SPOTTING-IN.**—Use this procedure to visually determine whether or not the seat or disk make good contact with each other. To spot-in a valve seat, first apply a thin coating of prussian blue evenly over the entire machined face surface of the disk. Next, insert the disk into the valve and rotate it a quarter turn, using a light downward force. The prussian blue will adhere to the valve seat at points where the disk makes contact. Figure 13-3 shows the patterns of prussian blue on a correct seat and on imperfect seats. After you have noted the condition of the seat surface, wipe all the prussian blue off of the disk face surface, then apply a thin, even coat on the contact face of the seat. Again place the disk on the valve seat and rotate the disk a quarter turn. Examine the resulting blue ring on the valve disk. If the ring is unbroken and of uniform width, and there are no cuts, scars, or irregularities on the face, the disk is in good condition. If the ring is broken or wavy, the disk is not making proper contact with the seat and must be machined.

**GRINDING.**—Valve grinding is the method of removing small irregularities from the contact surfaces

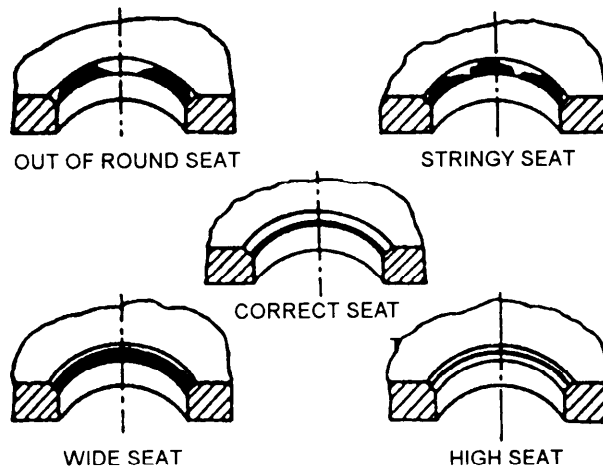


Figure 13-3.—Examples of spotted-in valve seats.

of the seat and disk. You also will use this process to on seats or disks you have machined.

To grind-in a valve, apply a small amount of grinding compound to the face of the disk, insert the disk into the valve and rotate the disk back and forth about a quarter turn. Shift the disk-seat relation from time to time so the disk will be rotated gradually in increments through several rotations. The grinding compound will gradually be displaced from between the seat and disk surfaces, so you must stop every minute or so to replenish the compound. For best results when you replenish, wipe the old compound off the seat and the disk before you apply the new compound. When it appears that the irregularities have been removed, spot-in the disk to the seat as described previously.

When you first spot-in a machined valve seat and disk, the seat contact will be very narrow and located close to the edge of the bore. Grinding-in, using finer compounds as the work progresses, causes the seat contact to become broader until it looks like the “correct seat” shown in figure 13-3. The contact area should be a perfect ring, covering approximately one-third of the seating surface.

Avoid over-grinding. It will produce a groove in the seating surface of the disk and it may round off the straight angular surface of the seat. You will have to machine the surfaces to correct the effects of overgrinding.

**LAPPING.**—Lapping serves the same purpose as grinding, but it works only on the valve seat and it removes slightly larger irregularities than grinding. In this procedure, you will use a cast-iron lapping tool that

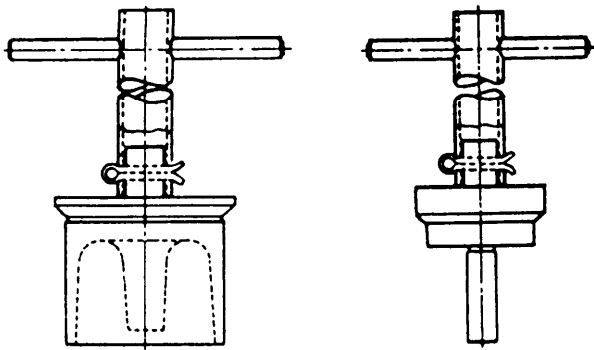


Figure 13-4.—Lapping tools.

has the same angle as the valve seat (fig. 13-4). You will use the lapping tool and grinding compounds in almost the same way you used the disk in the grinding process. However, you NEVER use the valve disk as a lap. The following list shows the essential points you must keep in mind while using the lapping tool:

- Do not bear heavily on the handle of the lap.
- Do not bear sideways on the handle of the lap.
- Shift the lap-valve seat relation so that the lap will gradually and slowly rotate around the entire seat circle.
- Check the working surface of the lap; if a groove wears on it, have the lap refaced.
- Use only clean compound.
- Replace the compound often.
- Spread the compound evenly and lightly.
- Do not lap more than is necessary to produce a smooth and even seat.

- Always use a fine grinding compound to finish the lapping job.
- When you complete the lapping job, spot-in and grind-in the disk to the seat.

Abrasive compound needed to grind-in and lap-in valve seats and disks is available in Navy stock in four grades. The following list shows grades and the recommended sequence of use:

GRADE	USE
Coarse	To lap-in seats that have deep cuts and scratches or extensive erosion.
Medium	To follow up the coarse grade: also may be used at the start of the reconditioning process where damage is not too severe.
Fine	To use when the reconditioning process nears completion.
Microscopic fine	To finish lap-in and do final grind-in.

**REFACING.**—The seat of a valve may be so deeply cut, scored, or corroded that lapping will not correct the condition. If so, you must machine it, or, in an extreme case, replace it with a new seat.

Many valves have removable seats that are threaded, welded, threaded and welded, or pressed into the valve body. In view A of figure 13-5, the valve seating surface has been welded so that it has become

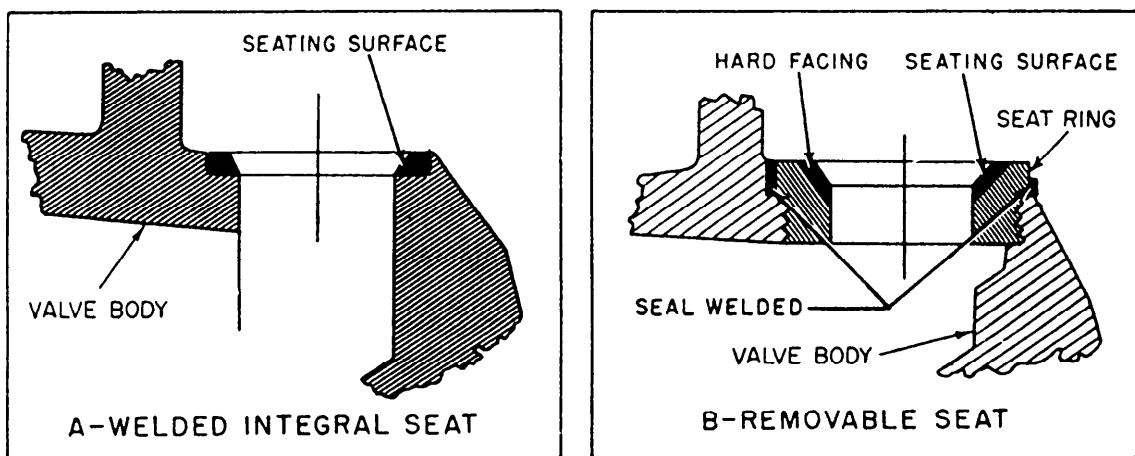


Figure 13-5.—Valve seat construction.

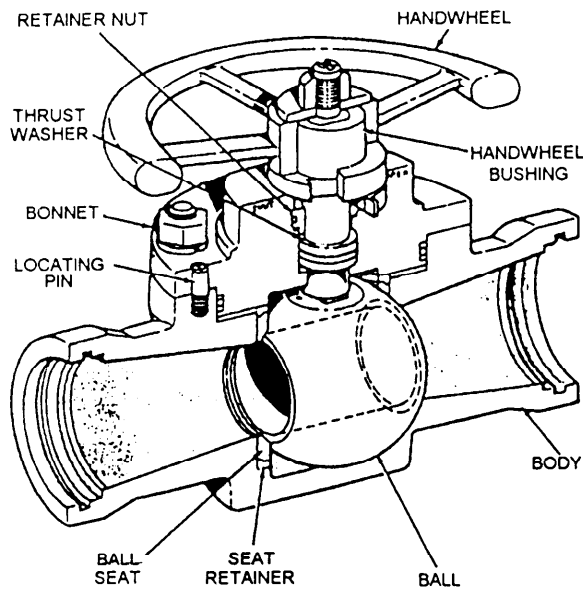


Figure 13-6.—Typical seawater ball valve.

an integral part of the valve body. In view B, the seating surface has been welded so that it has become an integral part of the seat ring. The seat ring is threaded into the body and then seal-welded. If you must renew the seating surface of A, you need only machine away the existing weld material and then rebuild the seating surface with successive deposits of new weld material. Then you can machine a new seating surface. If you must renew the seating surface shown in view B, first machine the seal weld from the ring and remove the ring from the valve body. You may then either install a new seat ring or remove, rebuild, and machine the existing seat surface.

After you have completed the machining, spot-in, and lightly grind-in the seat and disk. Then respot the seat and disk to be sure contact between the two is as it should be.

### Repairing Ball Valves

Ball valves, as the name implies, are stop valves that use a ball to stop or start the flow of fluid. The ball, shown in figure 13-6, performs the same function as the disk in a globe valve. When you turn the handwheel to open the valve, the ball rotates to a point where the hole through the ball is in line with the valve body inlet and outlet. When you shut the valve, the ball rotates so the hole is perpendicular to the flow openings of the valve body, and the flow stops.

Most ball valves are the quick-acting type; they require only a 90-degree turn of a simple lever or

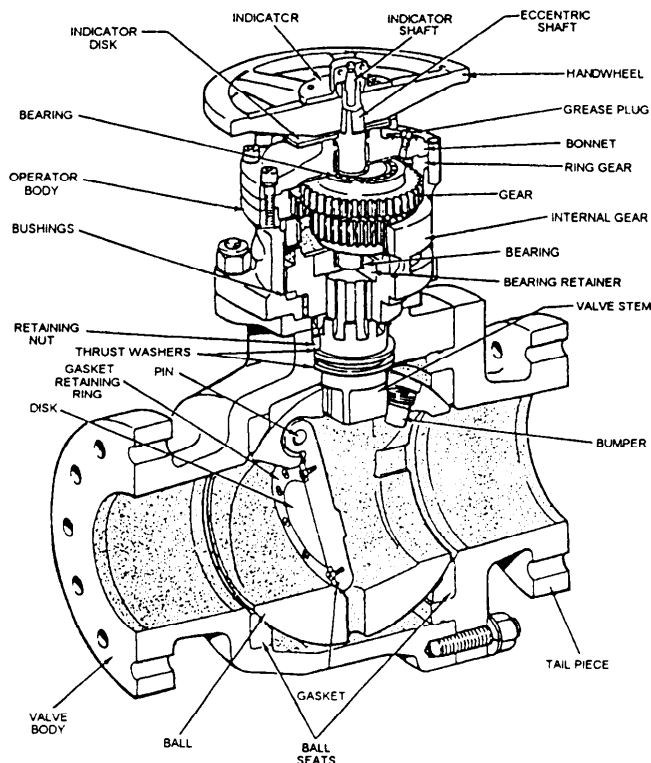


Figure 13-7.—Typical ball stop swing-check valve for seawater service.

handwheel to completely open or close the valve. Others are operated by planetary gears that use a relatively small handwheel and opening force to operate a fairly large valve. The gearing does, however, increase the time needed to open and close the valve. Some ball valves have a swing-check located within the ball to give the valve a check valve feature. Figure 13-7 shows a ball stop swing-check valve with planetary gear operation. Ball valves are normally found in the following systems aboard ship: seawater, sanitary, trim and drain, air, hydraulic, and oil transfer. Portsmouth Process Instruction 4820-921-339D contains repair procedures for ball valves. In the smaller types, you will normally replace parts rather than machine and rebuild them.

### Repairing Gate Valves

Gate valves answer a need for a straight line flow of fluid with minimum flow restriction. Gate valves are so named because the part (gate) that either stops or allows flow through the valve acts somewhat like the opening or closing of a gate. The gate is usually wedge-shaped. When the valve is wide open, the gate is fully drawn up into the valve. This leaves an opening for flow through the valve that is the same size as the



pipe in which the valve is installed. Gate valves are not suitable for throttling purposes because turbulence makes it difficult to control flow. Also, fluid force against a partially open gate causes it to vibrate, causing extensive damage to the valve.

Gate valves are classified as either rising stem (fig. 13-8) or nonrising stem valves (fig. 13-9). In a rising stem gate valve, the stem is attached to the gate, and the gate and the stem rise and lower together as the valve is operated. In a nonrising stem gate valve, the stem is threaded on its lower end into the gate. As you rotate the handwheel on the stem, the gate travels up or down the stem on the threads while the stem remains vertically stationary. This type of valve almost always has a pointer type of indicator threaded onto the upper end of the stem to show the gate's position.

With this basic information on the principles of the gate valve, you are ready to learn about repair procedures and the manufacture of repair parts.

You should use lapping to correct defects such as light pitting or scoring and imperfect seat contact. Use a lapping tool designed for the type of valve to be reconditioned. NEVER use the gate as a lap.

Use the same lapping process for gate valves that we described earlier for globe valves. But with gate valves, turn the lap by a handle extending through the inlet or outlet end of the valve body. Insert the lapping tool, minus the handle, into the valve so you cover one of the seat rings. Then attach the handle to the lap and begin the lapping work. You can lap the wedge gate to a true surface by using the same lap you used on the seat rings. In some cases when a gate is worn beyond repair and a shim behind the seat will not give a proper seat, you may need to plate the gate or seat.

**NOTE:** A shim has to be applied behind both seats to maintain the proper angle.

As another alternative, you may weld repair the damaged gate, then use a mill or lathe with an angle plate or fixture to machine it to its original specifications. Plating has one advantage over welding; the selective brush plating method does not heat the gate. When you build up metal by welding, it always heats the surfaces and can cause loss of temper or other weaknesses in the metal.

### Repairing Constant-Pressure Governors

Many turbine driven pumps are fitted with special valves called constant-pressure governors. This

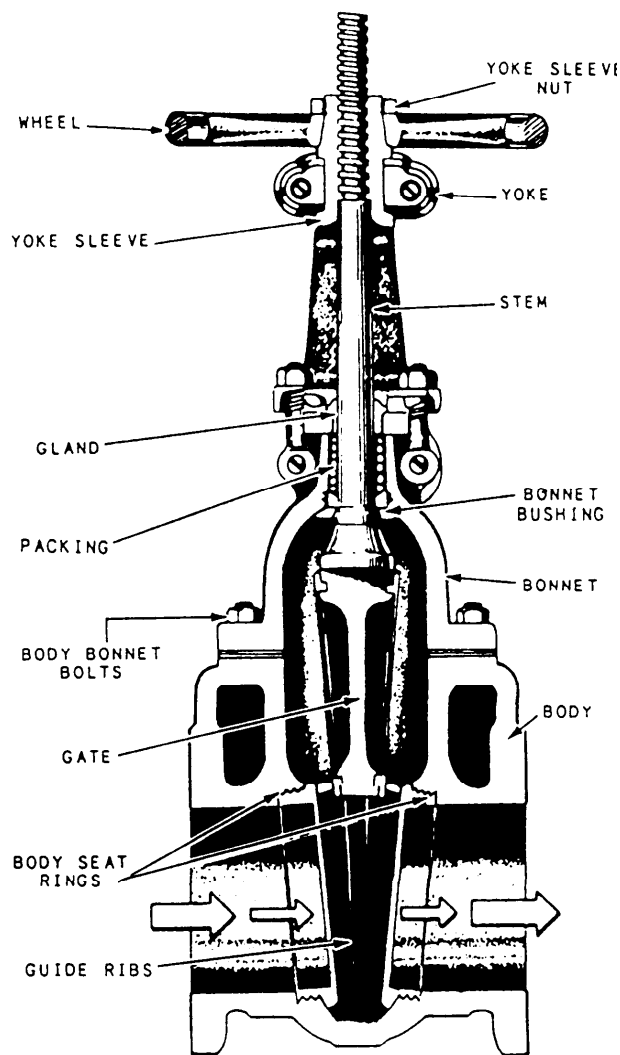
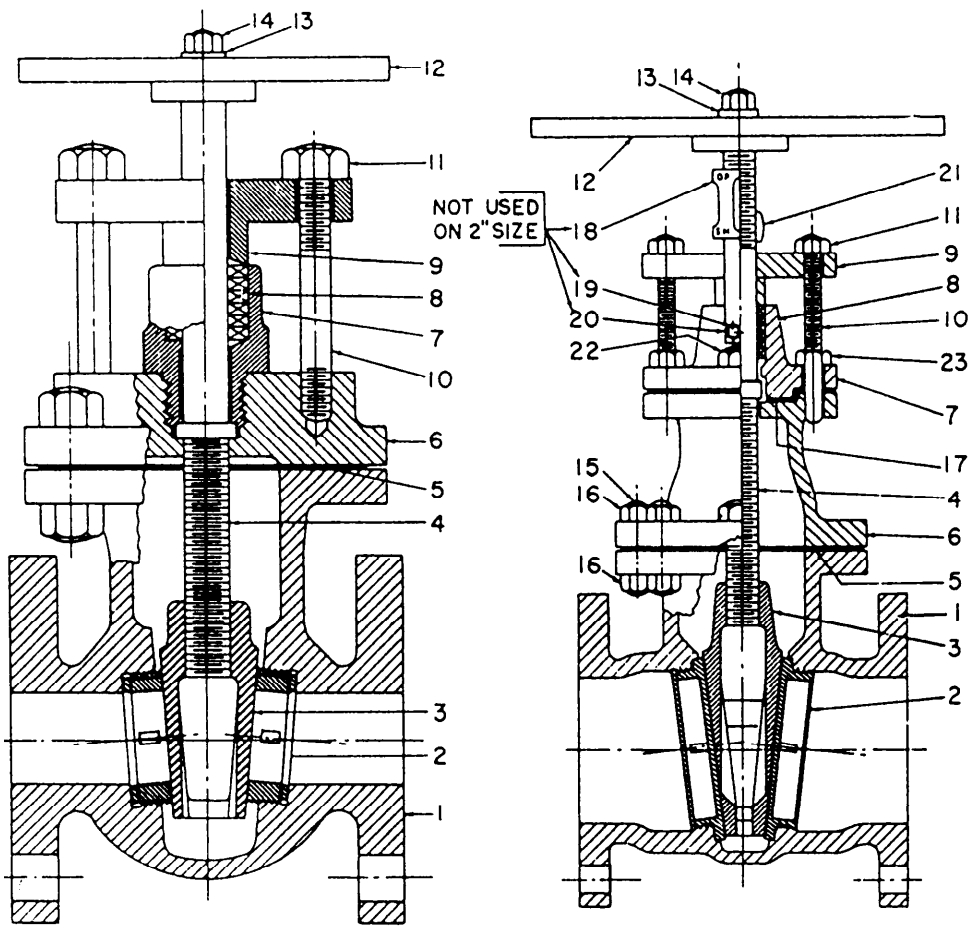


Figure 13-8.—Cutaway view of a gate stop valve (rising stem type).

governor maintains a constant pump discharge pressure under varying conditions of load. It is installed in the steam line to the pump. It controls the amount of steam admitted to the driving turbine, thereby controlling the pump discharge pressure.

Two of the most common types of constant-pressure pump governors used by the Navy are the Leslie and the Atlas. The two are very similar in operating principles. Our discussion is based on the Leslie governor, but most of the information also applies to the Atlas governor.



LIST OF PARTS			
PART NO.	NAME OF PART	PART NO.	NAME OF PART
1	BODY	13	HANDWHEEL WASHER
2	SEAT RING	14	HANDWHEEL NUT
3	GATE	15	BONNET STUD
4	STEM	16	BONNET STUD NUT
5	BONNET GASKET	17	STUFFING BOX GASKET
6	BONNET	18	INDICATOR PLATE
7	STUFFING BOX	19	LOCK WASHER
8	PACKING	20	INDICATOR PLATE SCREW
9	GLAND	21	INDICATOR NUT
10	GLAND STUD	22	STUFFING BOX STUD
11	GLAND STUD NUT	23	STUFFING BOX STUD NUT
12	HANDWHEEL		

Figure 13-9.—Cross-sectional views of gate stop valves (nonrising stem type).

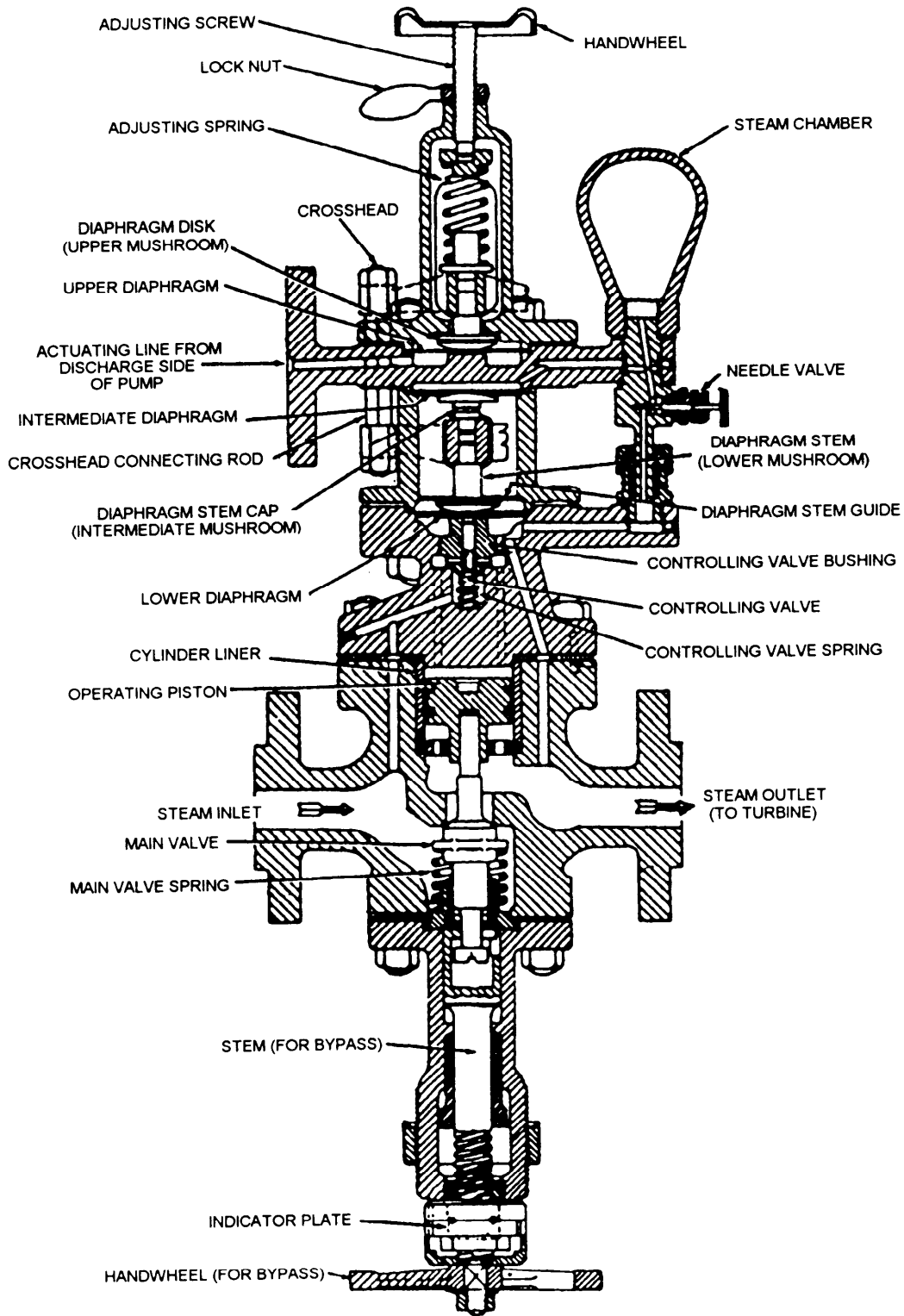


Figure 13-10.—Constant-pressure governor for main feed pump.

Figure 13-10 shows a Leslie constant-pressure governor for a main feed pump. The governors used on fuel oil service pumps, lube oil service pumps, fire and flushing pumps, and various other pumps are almost identical. The chief difference between governors used

for different services is in the size of the upper diaphragm. A governor used for a pump that operates with a high discharge pressure has a smaller upper diaphragm than one used for a pump that operates with a low discharge pressure.

Two opposing forces are involved in the operation of a constant-pressure pump governor. Fluid from the pump discharge, at discharge pressure, is led through an actuating line to the space below the upper diaphragm. The pump discharge pressure exerts an UPWARD force on the upper diaphragm. Opposing this, an adjusting spring exerts a DOWNWARD force on the upper diaphragm.

When the downward force of the adjusting spring is greater than the upward force of the pump discharge pressure, the spring forces both the upper diaphragm and the upper crosshead downward. A pair of connecting rods connects the upper crosshead rigidly to the lower crosshead, so the entire assembly of upper and lower crossheads moves together. When the crosshead assembly moves downward, it pushes the lower mushroom and the lower diaphragm downward. The lower diaphragm is in contact with the controlling valve. When the lower diaphragm is moved downward, the controlling valve is forced down and open.

The controlling valve is supplied with a small amount of steam through a port from the inlet side of the governor. When the controlling valve is open, steam passes to the top of the operating piston. The steam pressure acts on the top of the operating piston, forcing the piston down and opening the main valve. The extent to which the main valve is opened controls the amount of steam admitted to the driving turbine. Increasing the opening of the main valve therefore increases the supply of steam to the turbine and so increases the speed of the turbine.

The increased speed of the turbine is reflected in an increased discharge pressure from the pump. This pressure is exerted against the underside of the upper diaphragm. When the pump discharge pressure has increased to the point that the upward force acting on the underside of the upper diaphragm is greater than the downward force exerted by the adjusting spring, the upper diaphragm is moved upward. This action allows a spring to start closing the controlling valve, which, in turn, allows the main valve spring to start closing the main valve against the now-reduced pressure on the operating piston. When the main valve starts to close, the steam supply to the turbine is reduced, the speed of the turbine is reduced, and the pump discharge pressure is reduced.

At first glance, it might seem that the controlling valve and the main valve would open and close constantly and the pump discharge pressure would vary continually over a wide range. But this does not happen because the governor prevents such excessive opening or closing. An intermediate diaphragm bears against an intermediate mushroom, which, in turn, bears against

the top of the lower crosshead. Steam is led from the governor outlet to the bottom of the lower diaphragm and also through a needle valve to the top of the intermediate diaphragm. A steam chamber provides a continuous supply of steam at the required pressure to the top of the intermediate diaphragm.

Any up or down movement of the crosshead assembly is therefore opposed by the force of the steam pressure acting on either the intermediate diaphragm or the lower diaphragm. The whole arrangement prevents extreme reactions of the controlling valve in response to variations in pump discharge pressure.

Limiting the movement of the controlling valve in the manner just described reduces the amount of hunting the governor must do to find each new position. Under constant-load conditions, the controlling valve takes a position that causes the main valve to remain open by the required amount. A change in load conditions causes momentary hunting by the governor until it finds the new position required to maintain pump discharge pressure at the new load.

A pull-open device, consisting of a valve stem and a handwheel, is fitted to the bottom of the governor. Turning the handwheel to the open position draws the main valve open and allows full steam flow to the turbine. When the main valve is opened with the handwheel, the turbine must be controlled manually. Under all normal operating conditions, the bypass remains closed and the pump discharge pressure is raised or lowered, as necessary, by increasing or decreasing the tension on the adjusting spring.

**CONTROL AND MAIN VALVE.**—If there is leakage in the generator through the control valve or its bushing, steam will flow to the top of the operating piston, opening the main valve, and holding it open, even though there is no tension on the adjusting spring. The main valve must be able to close off completely or else the governor cannot operate properly. The only remedy is to disassemble the governor and stop the steam leakage. In most instances, you must renew the control valve. If the leakage is through the bottom of the bushing and its seat, you must lap the seat. A cast-iron lap is best for this type of work.

Rotate the lap through a small angle of rotation, lift it from the work occasionally, and move it to a new position as the work progresses. This will ensure that the lap will slowly and gradually rotate around the entire seat circle. Do not bear down heavily on the handle of the lap. Replace the compound often, using only clean compound. If the lap should develop a groove or cut, redress the lap. Continue lapping only long enough to remove all damaged areas.

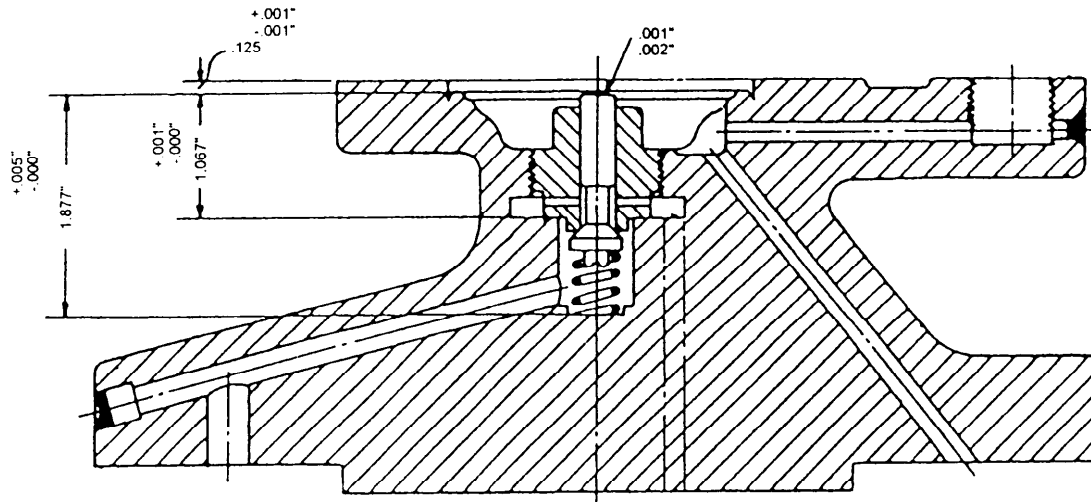


Figure 13-11.—Critical dimensions of the Leslie top cap.

When you install the control valve and its bushing, remember that the joint between the bottom of the bushing and its seat is a metal-to-metal contact. Install the bushing tightly, and when it is all the way down, tap the wrench lightly with a hammer, to ensure a steam-tight joint.

When the controlling valve is installed, you must check the clearance between the top of the valve stem and the diaphragm. It is absolutely mandatory that this clearance be between 0.001 and 0.002 inch (fig. 13-11). If the clearance is less than 0.001 inch, the diaphragm will hold the control valve open, allowing steam to flow to the main valve at any time the throttle valve is open. If the clearance is more than 0.002 inch, the diaphragm will not fully open the control valve. This means the main valve cannot open fully, and the unit cannot be brought up to full speed and capacity.

When the main valve seating area is damaged, it must be lapped in by the same process. ALWAYS lap in the main valve with the piston in the cylinder liner to ensure perfect centering.

If the damage to the seating surfaces is excessive, you must install new parts. Use parts supplied by the manufacturer if they are available.

**TOP CAP.**—If the top flange of the top cap of the governor becomes damaged, you must be extremely careful when you machine it. Consult the manufacturer's technical manual for the correct clearances. (See fig. 13-11.)

All seating surfaces must be square with the axis of the control valve seat threads and must have the smoothest possible finish. Before you start the reassembly, be sure that all ports in the top cap and the diaphragm chamber are free of dirt and other foreign matter. Be sure that the piston rings are free in their

grooves and that the cylinder liner is smooth and free of grooves, pits, and rust.

When installing the cylinder liner, be sure the top of the liner does not extend above the top of the valve body. The piston must work freely in the liner; if there is binding, the governor will not operate satisfactorily. Renew the controlling valve spring and the main valve spring if they are weak, broken, or corroded, or if they have taken a permanent set. Renew all diaphragms if necessary. If you use the old diaphragms, install them in their original position; do not reverse them.

Follow the instructions in the manufacturer's technical manual when you reassemble the governor. All clearances must be as designed if the governor is to operate satisfactorily. Check each moving part carefully to ensure freedom of movement.

When you have reassembled the governor, test it as soon as possible so that you can make any needed corrections.

### Repairing Double-Seated Valves

On a double-seated valve, the extent of damage determines the kind of repairs you can do. Normally, you can lap it or weld-repair it and remachine it to fit the body. The normal seat angles are the same as those in globe valves, and the spotting-in procedure is the same. You can hold most valve disks on a spud or mount them on a mandrel and cut them the same way as a globe valve. In this case as in the others, it is best to consult local quality assurance directives and local procedures when you repair this type of valve. Also, in most cases the blueprints will show ND (no deviations) and must be closely adhered to, as far as type of weld and quality. In all cases, shop LPO's should be able to provide the necessary information.

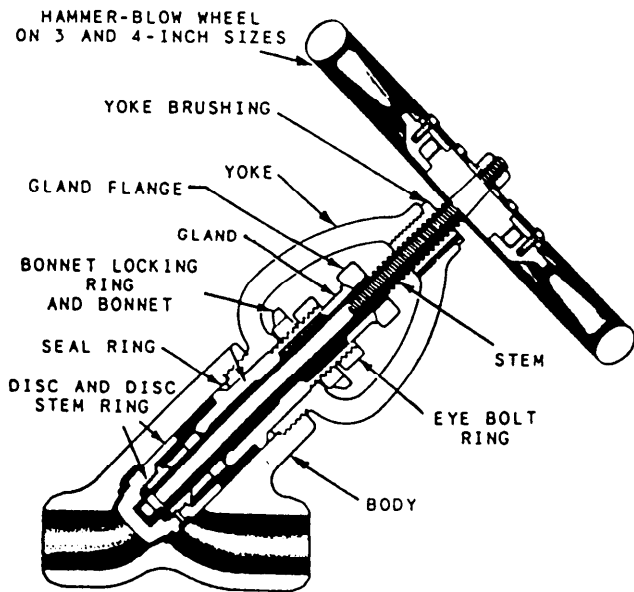


Figure 13-12.—1500-pound pressure seal bonnet globe valve.

### Repairing Duplex Strainer Plug Valves

The most common reason to repair duplex strainers is scored or chipped O-ring grooves or scored or scratched liners. In some cases you may need to

weld-repair the plug cock and machine it back to blueprint specifications. If you need to repair the strainer body, you will usually hone it, and in some cases you will use an oversized O-ring. Consult local type commander and QA procedures for the best method. Check with the shop's leading petty officer before you undertake any repair procedures.

### Repairing Pressure Seal Bonnet Globe Valves

The repairs you may do on pressure seal bonnet globe valves (fig. 13-12) usually are limited to repair of the seat and disk and the manufacture of silver seals. Sometimes you may manufacture parts or be involved in a weld-repair. Always follow your controlled work package carefully.

### REPAIRING PUMPS

*Fireman*, NAVEDTRA 12001, provides a description of the common types and uses of pumps aboard ship. You will do most of your pump repairs on centrifugal pumps, so we'll limit this discussion to that type.

Figure 13-13 shows the internal parts of a centrifugal pump. Look at the arrangement of the impeller,

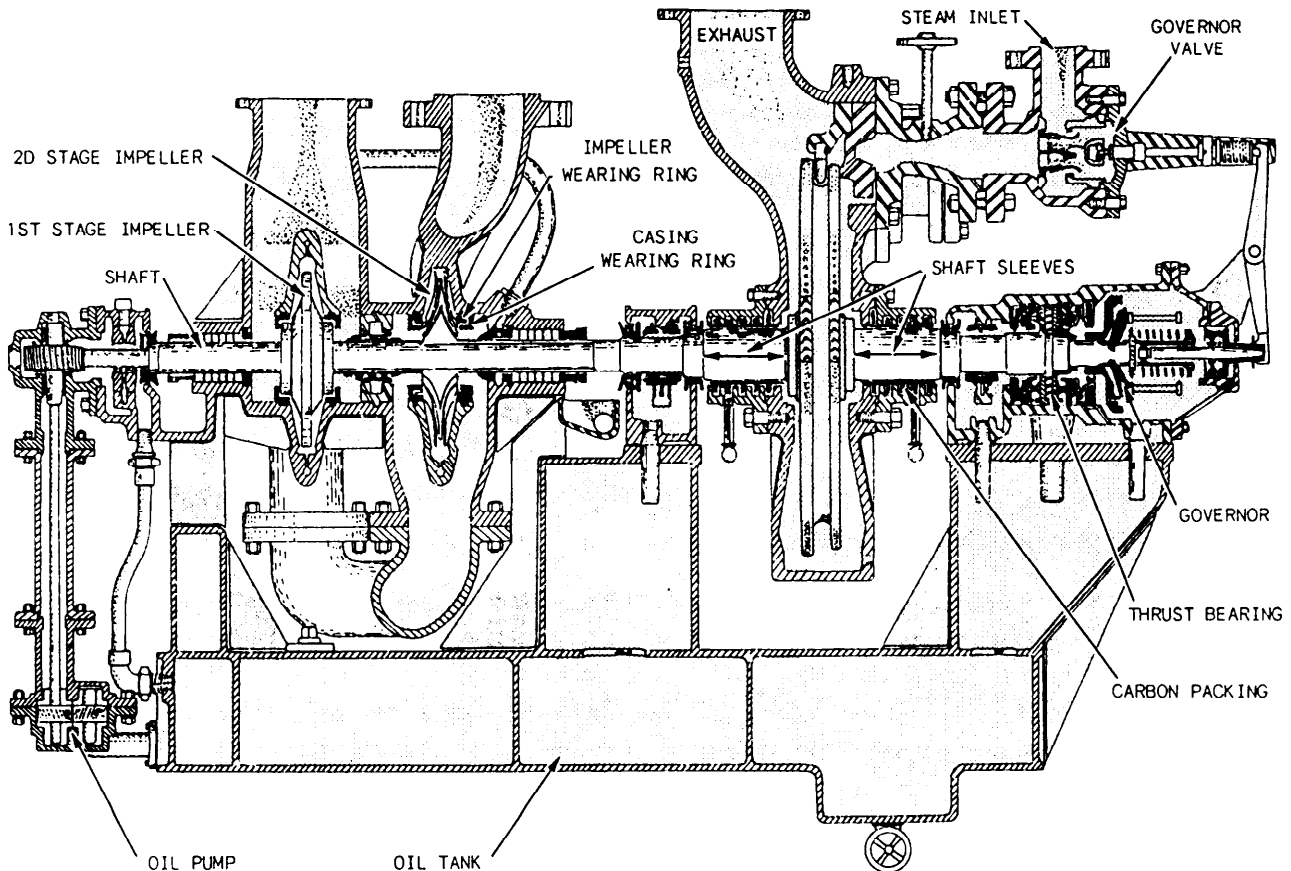


Figure 13-13.—Two-stage main feed pump.

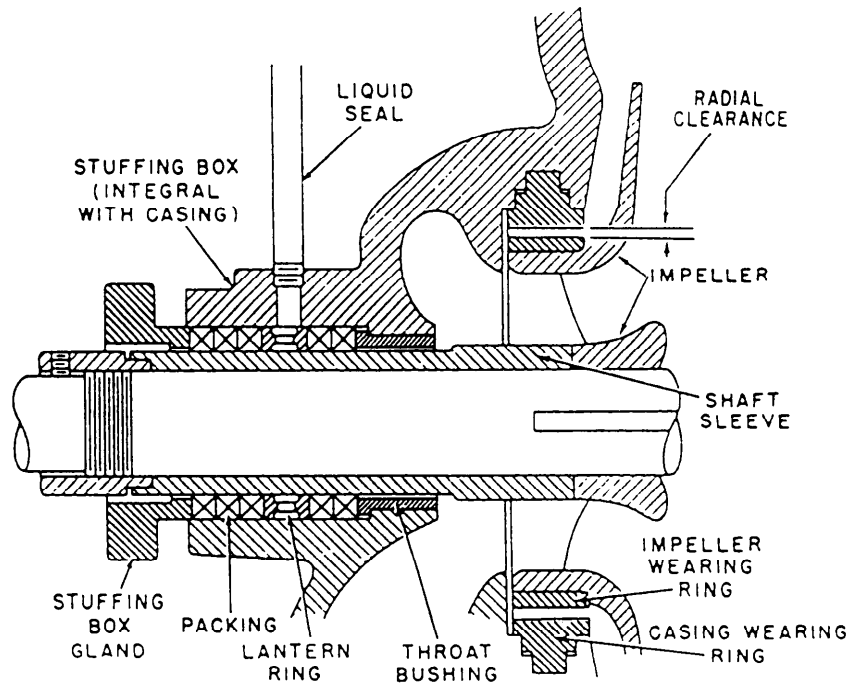


Figure 13-14.—Stuffing box on a centrifugal pump.

casing wearing rings, impeller wearing rings, shaft, and shaft sleeves in particular.

The operation of a centrifugal pump wears away both the area of the shaft that goes through the packing gland or mechanical seal and the casing-impeller sealing areas. They must be renewed from time to time to maintain the efficiency of the pump.

The shaft, casing, and impeller in a centrifugal pump are designed so they can be renewed without replacing them. The shafts have tightly fitted renewable sleeves, while the casing and impeller have renewable surfaces called casing wearing rings and impeller wearing rings. You can see the arrangement clearly in figure 13-14.

When it is necessary to renew these parts, the rotor assembly, consisting of the pump shaft, the impeller and its wearing ring, and the casing rings, is usually brought into the shop. The following paragraphs explain the method you should use to replace these parts.

The repair parts generally are available from the ship's allowance, but you may need to manufacture them. Before you proceed with these repairs, consult the manufacturer's technical manual and the applicable blueprints to get the correct information on vital clearances and other data.

In some pumps, the shaft sleeve is pressed onto the shaft with a hydraulic press, and you must machine off the old sleeve in a lathe before you can install a new one. On centrifugal pumps, the shaft sleeve is a snug slip-on fit, butted up against a shoulder on the shaft and held securely in place with a nut. The centrifugal pump sleeve-shaft-shoulder joint is usually made up with a hard fiber washer. It prevents liquid from leaking through the joint and out of the pump between the sleeve and shaft.

The impeller wearing ring is usually lightly press-fitted to the hub of the impeller and keyed in with headless screws (also called Dutch keyed). To remove the worn ring, withdraw the headless screws or drill them out and then machine the ring off in a lathe.

The amount of diametrical running clearance between the casing rings and the impeller rings affects the efficiency of a centrifugal pump. Too much clearance will let too much liquid leak back from the discharge side to the suction side of the pump. Not enough clearance will cause the pump to "freeze." Before you install a new wearing ring on the impeller, measure the outside diameter of the impeller wearing ring, and the inside diameter of the casing ring. (See fig. 13-15.) If the measurements do not agree with the lit and clearance data you have on hand, ask your

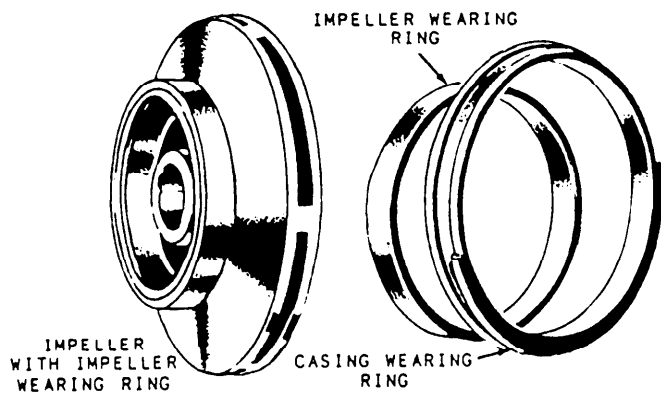


Figure 13-15.—Impeller, impeller wearing ring, and casing wearing ring for a centrifugal pump.

leading petty officer for instructions before you go any further. Sometimes it is necessary to take a light cut on the inside diameter of the impeller ring to get its correct press fit on the impeller hub. The difference between the outside diameter of the impeller wearing ring and the inside diameter of the casing wearing ring is the diametrical running clearance between the rings. If this clearance is too small, correct it by taking a cut on either the outside diameter of the impeller ring or the inside diameter of the casing ring. You also need to check the concentricity of the two rings. If they do not run true, machine their mating surfaces so they do run true. Be sure you keep the specified diametrical clearance.

When a pump like the one shown in figure 13-13 needs repairs, usually only the shaft assembly and casing wearing rings are brought to the shop. To renew the wearing rings and resurface the packing sleeves on this type of pump, take the following steps:

1. Clamp the casing wearing ring on a faceplate and align the circumference of the ring concentrically with the axis of the lathe spindle. (You can hold the casing rings in a 4-jaw chuck, but it may distort the ring.)
2. Take a light cut on the inside diameter of the casing ring to clean up the surface. Do this to all casing rings.
3. Mount the shaft assembly between centers or in a chuck and align its axis with the lathe axis.
4. Machine away the impeller wearing rings. Be careful not to cut into the impeller.

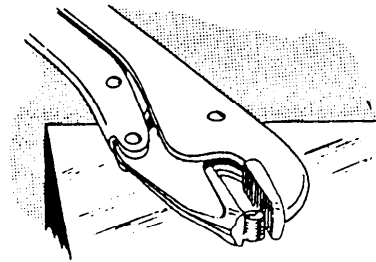


Figure 13-16.—Removing a broken stud with locking pliers.

5. Remove the shaft assembly from the lathe.
6. Make the impeller rings. The size of the inside diameter of the impeller rings should provide a press fit on the impeller. The outside diameter should be slightly larger than the inside diameter of the casing rings.
7. Press the impeller rings on the impeller and lock them in place with headless screws, if the blueprint specifies it.
8. Mount the shaft assembly back in the lathe and machine the diameter of the impeller rings to provide the proper clearance between impeller rings and casing rings. Blueprints and technical manuals list the clearance as either diametrical or radial clearance. Diametrical clearance is the total amount of clearance required. Radial clearance is one-half of the clearance required and must be doubled to get diametrical clearance.

## REMOVING BROKEN BOLTS AND STUDS

When you must remove a broken bolt or stud, flood the part being worked on with penetrating oil or oil of wintergreen. Soak the area for several hours or overnight if you have time. A good soaking may loosen a bolt that will otherwise have to be drilled out.

If enough of the broken piece protrudes, take hold of it with locking pliers, as shown in figure 13-16, and carefully try to ease it out. If you cannot turn the bolt, soak it further with penetrating oil. If the oil doesn't loosen the bolt, jar it with light hammer blows on the top and around the sides. This may loosen the threads so that you can remove the bolt with the pliers.



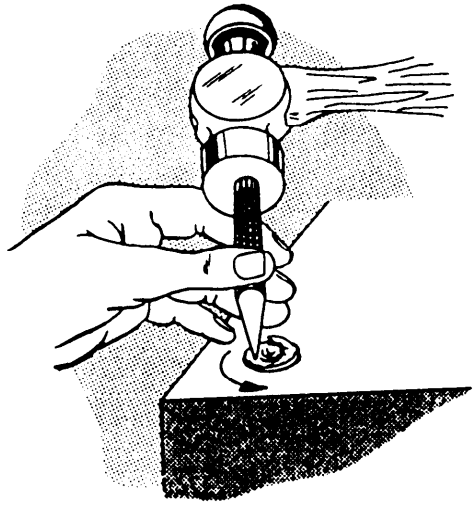


Figure 13-17.—Removing a broken bolt with a prick punch.

If a bolt has been broken off flush with the surface, you may sometimes back it out with light blows on a prick punch or center punch, as shown in figure 13-17.

To drill out a broken bolt and retap the hole, file the bolt smooth, if necessary, and centerpunch it. Then select a twist drill that is a little smaller than the tap-drill size for the particular bolt that has been broken. As shown in figure 13-18, this drill will just about but not quite touch the crests of the threads in the threaded hole or the roots of the threads on the threaded bolt. Carefully start drilling at the center punch mark. Crowd the drill one way or the other as necessary so that the hole will be drilled in the exact center of the bolt.

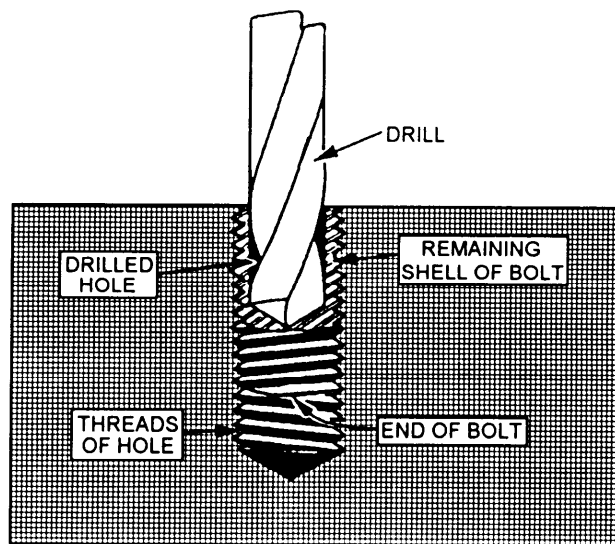


Figure 13-18.—Removing a broken bolt and retapping the hole to the same size.

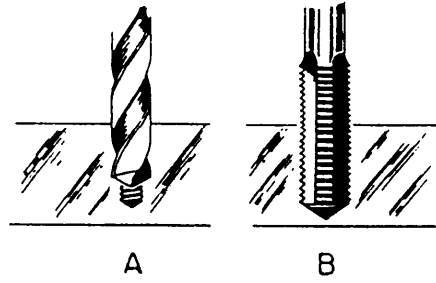


Figure 13-19.—Removing a broken bolt and retapping the hole to a larger size.

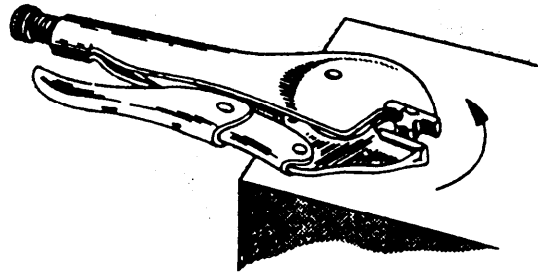


Figure 13-20.—Removing a broken tap with locking pliers.

The drill in figure 13-18 has almost drilled the remaining part of the bolt away and will eventually break through the bottom of the bolt. When this happens, all that will remain of the bolt will be a threaded shell. With a prick punch or other suitable tool, chip out and remove the first two or three threads, if possible, at the top of the shell. Then carefully start a tapered tap into these clean threads and continue

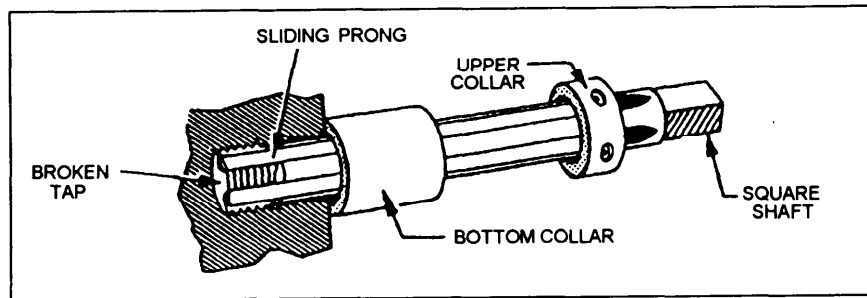


Figure 13-21.—Removing a broken tap with a tap extractor.

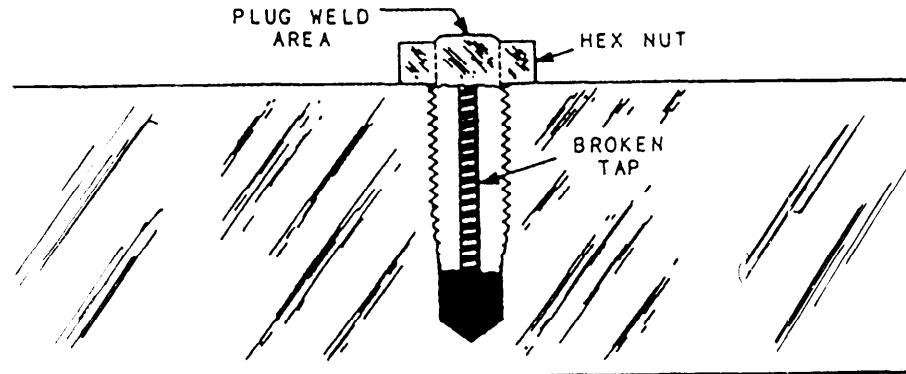


Figure 13-22.—Using a plug weld to remove a broken tap.

tapping until you have cut away the shell and restored the original threads.

In cases where it is not necessary to replace the capscrew or bolt with one of the same size, use a drill larger than the broken bolt to drill out the old bolt, as shown in figure 13-19, view A. Tap the hole first, and then finish it with a bottoming tap as shown in view B. Replace the original capscrew or stud with a larger size. Never do this without the concurrence of your QA office.

### REMOVING A BROKEN TAP FROM A HOLE

To remove a broken tap that protrudes from a hole, generously apply penetrating oil to the tap, working it down through the four flutes into the hole. Then grasp the tap across the flats with locking pliers. Figure 13-20 shows this operation. Carefully ease the tap out of the hole, adding penetrating oil as necessary.

If the tap has broken off at or slightly below the surface of the work, you may be able to remove it with the tap extractor shown in figure 13-21. Again, apply a liberal amount of penetrating oil to the broken tap. Place the tap extractor over the broken tap and lower the upper collar to insert the four sliding prongs down into the four flutes of the tap. Then slide the bottom collar down to the surface of the work so it will hold the prongs tightly against the body of the extractor. Tighten the tap wrench on the square shank of the extractor and carefully work the extractor back and forth to loosen the tap. You may need to remove the extractor and strike a few sharp blows with a small hammer and pin punch to jar the tap loose. Then reinsert the tap remover and carefully try to back the tap out of the hole.

Each size of tap requires its own size of tap extractor. They come in the following sizes: 1/4, 5/16, 3/8, 7/16, 1/2, 9/16, 5/8, 3/4, 7/8 and 1 inch.

When a tap extractor will not remove a broken tap, you may be able to do it with the plug weld method shown in figure 13-22. Place a hex nut over the tap and

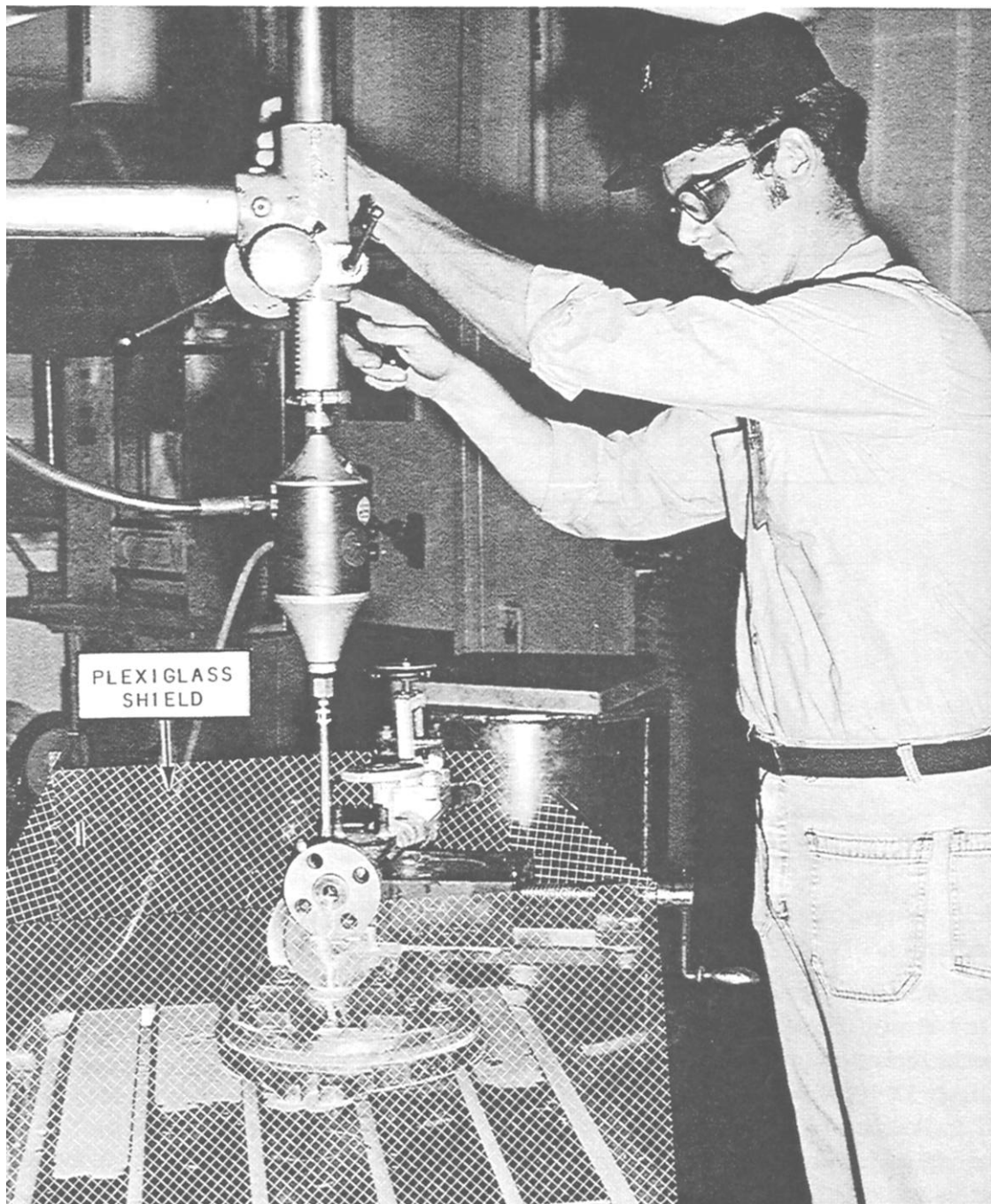


Figure 13-23.—Metal disintegrator removing a broken stud.

28.321

have it welded to the tap. Use a nut with a hole somewhat smaller than the tap diameter to avoid welding the nut and the tap to the job itself. Allow the weld to cool before you try to remove the tap. When the nut, tap, and job have come to room temperature, it often is helpful to quickly heat the

immediate area around the hole with an oxyacetylene torch. This quick heating expands the adjacent metal of the work and allows you to remove the tap more easily. If the heating is too slow, the tap will expand with the metal of the work and there will be no loosening effect.

## METAL DISINTEGRATORS

Sometimes you cannot remove a broken tap or stud with the usual methods we explained earlier in this chapter. In those cases, you may use a metal disintegrator to remove such a piece without damaging the part. This machine uses an electrically charged electrode that vibrates as it is fed into the work and disintegrates a hole through the broken tap or stud. The part to be disintegrated and the mating part that it is screwed into must be made from a material that will conduct electricity. Figure 13-23 shows a disintegrator being used to remove a broken stud.

You can find the specific operating procedure for the metal disintegrator in the operators material furnished by the manufacturer. However, we will explain several steps in the setup for a disintegrating job that are common to most of the models of disintegrators found aboard Navy ships.

First set up the part to be disintegrated. Some disintegrator models have a built-in table with the disintegrating head mounted above it much like a drill press. On a machine such as this, you need only bolt the part securely to the table and be sure the part makes good contact to provide an electrical ground. Align the tap or stud to be removed square with the table so the electrode will follow the center of the hole correctly. If there is misalignment, the electrode may leave the tap or stud and damage the part. Use either a machinist's square laid on the table or a dial indicator mounted on the disintegrating head to help align the part. If the part will not make an electrical ground to the table, or if the model of machine you are using is designed as an attachment to be mounted in a drill press spindle, attach the disintegrator's auxiliary ground cable to the part.

The diameter and length of the part to be removed determines the selection of the electrode. As a general rule, the electrode should be large enough in diameter to equal the smallest diameter of a tap (the distance between the bottom of opposite flutes). If you plan to remove a stud, the electrode must not be so large that a slight misalignment can cause it to burn or damage the part. Use a scribe and a small magnet to remove any of the stud material not disintegrated.

A free-flowing supply of clean coolant is an essential part of the disintegrating operation. The coolant is pumped from a sump to the disintegrating head and then through the electrode, which is hollow, to the exact point of the disintegrating action.

Different machines have different controls that you must set. However, most have a control to start the

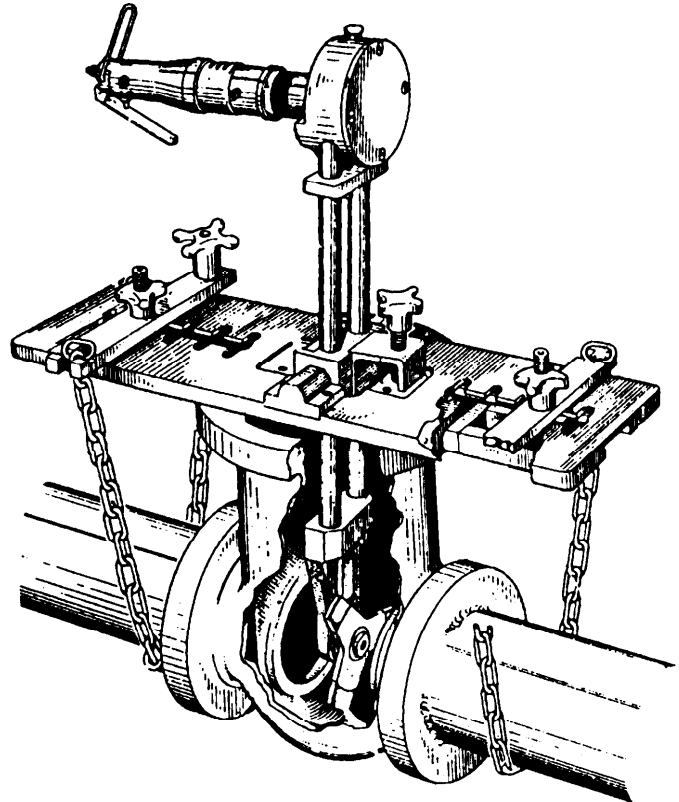


Figure 13-24.—Gate valve reseater.

disintegrating head vibrating and a selector switch for the heat or power setting. The position of this switch depends on the diameter of the electrode being used. Some models have an automatic feed control that regulates the speed that the electrode penetrates the part to be removed. Regardless of whether the feed is automatic or manual, do NOT advance so fast that it stops the disintegrating head and the electrode from vibrating. If this happens, the disintegrating action will stop and the electrode can be bent or broken.

## IN PLACE MACHINING

There are times when a job cannot be brought to the shop and the MR must go and do the job in place. Some examples of in-place machining include the repair of globe and gate valves, the resurfacing of pipe and valve flanges, boring valve inlay areas, and general machine work.

There are a number of machines you can use on these jobs. For example, you can use the gate valve grinder shown in figure 13-24 to reseal gate valves.

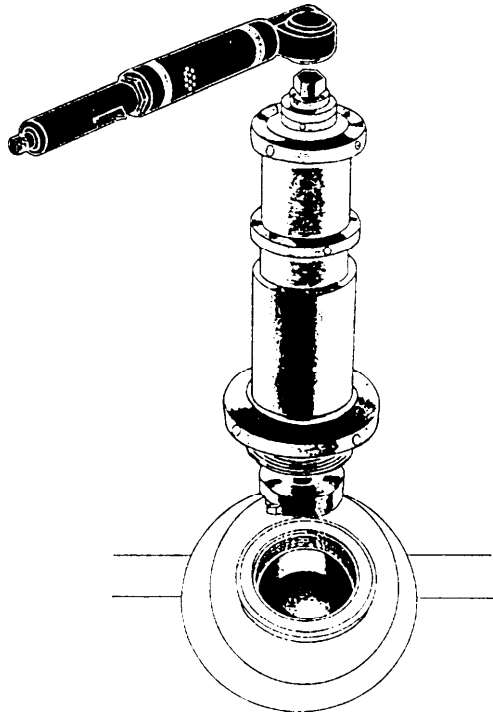


Figure 13-25.—Portable boring bar.

Figure 13-25 shows a portable boring bar. You can use it to bore the inlay area of high-pressure steam valves.

Figure 13-26 shows a Versa-Mil. You can use it to mill, shape, grind, and drill in place. You can mount a feed table to the base of the Versa-Mil that allows you to hand feed the machine. Only your imagination limits the different setups you can make with the Versa-Mil.

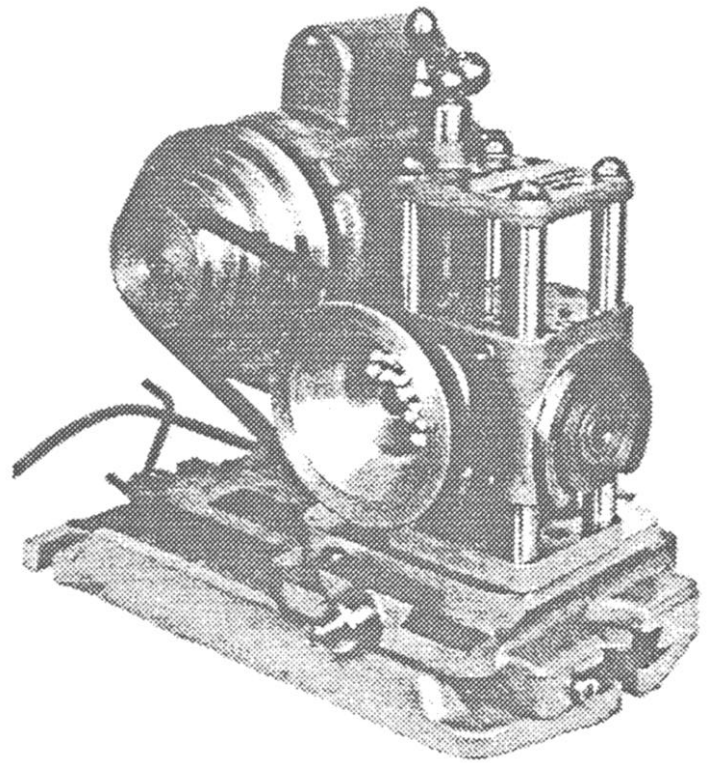


Figure 13-26.—Versa-Mil.

28.472

There are a number of companies that build in-place machining equipment and it is not feasible to cover all of them. We have only given you a brief overview of the types of machines you might use. Refer to your machine operator's manual for specific operating instructions.

## CHAPTER 14

# GEARS AND GEAR CUTTING

### CHAPTER LEARNING OBJECTIVES

*Upon completing this chapter, you should be able to do the following:*

- *Describe the materials used to manufacture gears.*
- *Explain the manufacture of gears, splines, and sprockets.*
- *Explain the process used to set up gear trains.*

This chapter covers the manufacture of spur gears, helical gears, bevel gears, stub tooth gears, worms, worm gears, splines, and sprockets.

Gears have always been a highly essential element in machinery used aboard ships and at naval shore facilities. In today's Navy, the emphasis on speed, power, and compactness in naval machinery has created special problems for the machinist cutting a gear. Today's machinists must be able to turn out a noiseless, practically unbreakable gear that transmits large amounts of power in small spaces. This requires great skill and precision.

This chapter will cover gear cutting practices on a standard milling machine. If you encounter problems when you calculate or cut gears, consult a machinist's handbook for more detailed information.

As with any shop equipment you must observe all posted safety precautions. Review your equipment operators manual for safety precautions. Also read any chapters of *Navy Occupational Safety and Health (NAVOSH) Program Manual for Forces Afloat*, OPNAV Instruction 5100.19B, that apply to the equipment.

### MATERIALS USED FOR GEARS

The choice of material for a particular gear is usually based on the function of the gear. This involves factors such as the speed of operation, the type of stress, the importance of quiet operation, and the need for resistance to corrosion. The easiest way to determine what material to use for a replacement gear is to find out what material was used for the gear you must replace. In most cases, you will have the original gear to go by.

If not, you may have to find the specifications or blueprints for the original gear. In some cases you should consult a machinist's handbook, which prescribes various materials. Do this to be sure the material you are using will hold up under the stresses the gear will encounter.

Gears are made from ferrous, nonferrous, and nonmetallic materials. Steel, for example, is used whenever great strength and toughness are required. Nonferrous metals such as bronze and brass are often used aboard naval ships for gears that must resist saltwater corrosion.

Monel and aluminum may be used for gears, where corrosion resistance is of primary importance. Non-metallic gearing is frequently used where quiet operation is important. Nonmetallic gears are most effective at high-speeds. However, they do not always hold up against the wide fluctuations of load and the high shock loads encountered at low speeds. Gears made of nonmetallic materials have a lower tensile strength than those constructed of metallic materials, but their greater resiliency gives them approximately the same power-transmitting capacity as cast iron.

### SPUR GEARS

A gear is made by cutting a series of equally spaced, specially shaped grooves on the periphery of a wheel (see fig. 14-1).

To calculate the dimensions of a spur gear, you must know the parts of the gear. You also must know the formulas for finding the dimensions of the parts. To cut the gear you must know what cutter to use and how

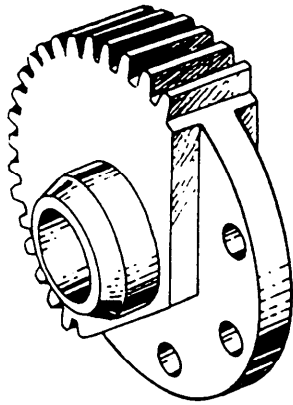


Figure 14-1.—Cutting specially shaped grooves.

to index the blank, so the teeth are equally spaced and have the correct profile.

### SPUR GEAR TERMINOLOGY

The following terms (see fig. 14-2) describe gears and gear teeth. The symbols in parentheses are standard gear nomenclature symbols used and taught at MR schools.

**OUTSIDE CIRCLE (OC):** The circle formed by the tops of the gear teeth

**OUTSIDE DIAMETER (OD):** The diameter to which you will turn the blank or the overall diameter of the gear

**PITCH CIRCLE (PC):** The contact point of mating gears, the basis of all tooth dimensions, or an imaginary circle one addendum distance down the tooth

**PITCH DIAMETER (PD):** The diameter of the pitch circle. In parallel shaft gears, you can determine the pitch diameter directly from the center-to-center distance and the number of teeth.

**ROOT CIRCLE (RC):** The circle formed by the bottoms of the gear teeth

**ROOT DIAMETER (RD):** The distance through the center of the gear from one side of the root circle to the opposite side

**ADDENDUM (ADD):** The height of the part of the tooth that extends outside the pitch circle

**CIRCULAR PITCH (CP):** The distance from a point on one tooth to a corresponding point on the next tooth measured on the pitch circle

**CIRCULAR THICKNESS (CT):** One-half of the circular pitch, or the length of the arc between the two sides of a gear tooth on the pitch circle.

**CLEARANCE (CL):** The space between the top of the tooth of one gear and the bottom of the tooth of its mating gear

**DEDENDUM (DED):** The depth of the tooth inside the pitch circle, or the radial distance between the root circle and the pitch circle

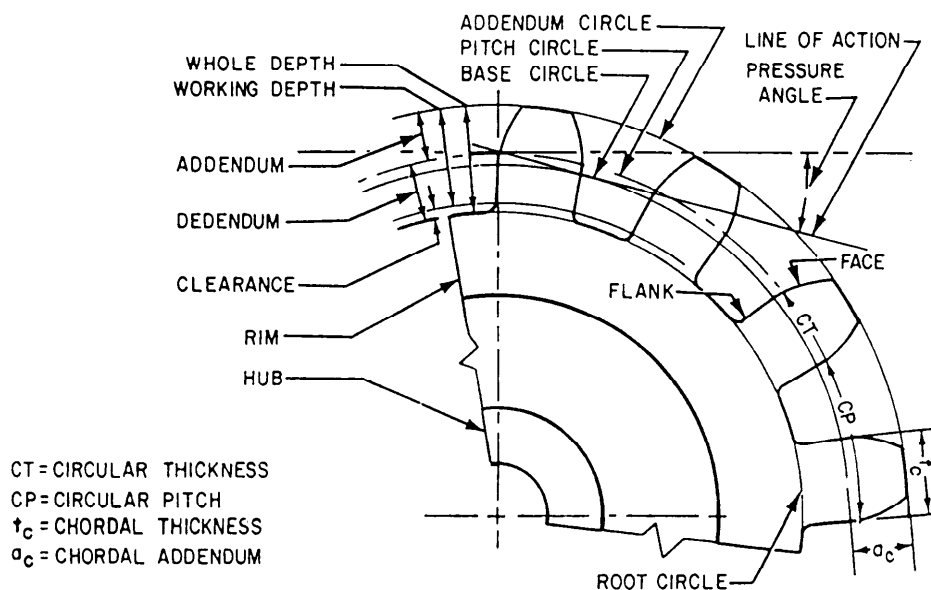


Figure 14-2.—Gear terminology.

WHOLE DEPTH (WD): The radial depth between the circle that bounds the top of the gear teeth and the circle that bounds the bottom of the gear teeth

WORKING DEPTH (WKD): The whole depth minus the clearance, or the depth of engagement of two mating gears; the sum of their addendums

CHORDAL THICKNESS ( $t_c$ ): The thickness of the tooth measured at the pitch circle or the section of the tooth that you measure to see if the gear is cut correctly

CHORDAL ADDENDUM ( $a_c$ ): The distance from the top of a gear tooth to the chordal thickness line at the pitch circle (used to set gear tooth vernier calipers to measure tooth thickness)

DIAMETRICAL PITCH (DP): The most important calculation because it regulates the tooth size, or the number of teeth on the gear divided by the number of inches of pitch diameter

NUMBER OF TEETH (NT): The actual number of teeth of the gear

BACKLASH (B): The difference between the tooth thickness and the tooth space of engaged gear teeth at the pitch circle

The symbols the American Gear Manufacturers Association uses to describe gears and gear teeth are different from those the Navy uses. The following list will familiarize you with both sets of symbols:

	<b>Machinery Repairman</b>	<b>American Gear Manufacturers</b>
<u>Spur Gear Terms</u>	<u>School Abbreviations</u>	<u>Association Abbreviations</u>
Pitch circle	PC	(none)
Pitch diameter	PD	D
Center-to-center distance	C-C	C
Addendum	ADD	a
Dedendum	DED	d
Working depth	WKD	hk
Clearance	CL	C
Whole depth	WD	ht
Root circle	RC	(none)

**Machinery  
Repairman**      **American Gear  
Manufacturers**

<u>Spur Gear Terms</u>	<u>School Abbreviations</u>	<u>Association Abbreviations</u>
Outside diameter	OD	Do
Circular thickness	CT	tc
Circular pitch	CP	P
Diametral pitch	DP	P
Number of teeth	NT	N
Root diameter	RD	DR
Chordal thickness	$t_c$	(none)
Chordal addendum	$a_c$	(none)

**DIAMETRICAL PITCH SYSTEM**

The diametral pitch system was devised to simplify gear calculations and measurements. It is based on the diameter of the pitch circle rather than on the circumference. Since the circumference of a circle is 3.1416 times its diameter, you always must consider this constant when you calculate measurements based on the pitch circumference. In the diametral pitch system, however, the constant is in a sense “built into” the system to simplify computation.

When you use this system, there is no need to calculate circular pitch. Indexing devices based on the diametral pitch system will accurately space the teeth, and the formed cutter associated with the indexing device will form the teeth within the necessary accuracy. This system simplifies all calculations such as center distance between gears and working depth of teeth.

Many formulas are used to calculate the dimensions of gears and gear teeth, but we will only use those needed in this discussion. Appendix III of this manual contains a more complete list of such formulas. Appendix IV contains explanations of how you determine the formulas to calculate the dimensions of gear teeth.

Usually, you can get the outside diameter (OD) of a gear and the number of teeth (NT) from a blueprint or a sample gear. You may then use these two known factors to calculate the necessary data.



For example, use the following procedure to make a gear 3.250 inches in diameter that has 24 teeth:

1. Find the pitch diameter (PD) by using the formula:

$$PD = \frac{(NT) OD}{NT + 2}$$

$$PD = \frac{24 \times 3.250}{24 + 2} = \frac{78}{26} = 3.000 \text{ inches}$$

2. Find the diametral pitch (DP) by using the formula:

$$DP = \frac{NT}{PD}$$

$$DP = \frac{24}{3} = 8$$

3. Find the whole depth of tooth (WD) by using the formula:

$$WD = \frac{2.157}{DP}$$

$$WD = \frac{2.157}{8} = 0.2696 \text{ inch}$$

You can select the cutter to machine the gear teeth as soon as you compute the diametral pitch. Formed gear cutters are made with eight different forms (numbered from 1 to 8) for each diametral pitch. The number of the cutter depends upon the number of teeth the gear will have. The following chart shows which cutter to use to cut various numbers of teeth on a gear.

If, for example, you need a cutter for a gear that has 24 teeth, use a No. 5 cutter since a No. 5 cutter will cut all gears containing from 21 to 25 teeth.

<u>Range of teeth</u>	<u>Number of cutter</u>
135 to a rack	1
55 to 134	2
35 to 54	3
26 to 34	4
21 to 25	5
17 to 20	6
14 to 16	7
12 to 13	8

Most cutters are stamped to show the number of the cutter, the diametral pitch, the range for the number of the cutter, and the depth. Involute gear cutters usually

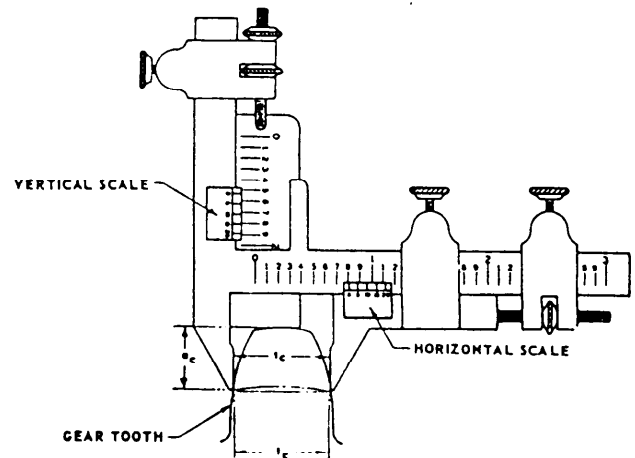


Figure 14-3.—Measuring gear teeth with a vernier caliper.

run from 1 to 48 diametral pitch and 8 cutters to each pitch.

To check the dimensional accuracy of gear teeth, use a gear tooth vernier caliper (see fig. 14-3). The vertical scale is adjusted to the chordal addendum ( $a_c$ ) and the horizontal scale is used to find the chordal thickness ( $t_c$ ). Before you calculate the chordal addendum, you must determine the addendum (ADD) and circular thickness ( $C_t$ ).

To determine the addendum, use the formula:

$$ADD = \frac{PD}{NT}$$

Using the values from the preceding example,

$$ADD = \frac{3.000}{24} = 0.125 \text{ inch}$$

To determine the circular thickness, use the formula:

$$CT = \frac{1.5708}{DP}$$

Using the values from the preceding example,

$$CT = \frac{1.5708}{8} = 0.1964 \text{ inch}$$

The formula used to find the chordal addendum is

$$\begin{aligned} a_c &= ADD + \frac{(CT)^2}{4(PD)} \\ &= 0.125 + \frac{(0.1964)^2}{4 \times 3} \\ &= 0.125 + \frac{(0.0386)}{12} = 0.128 \text{ inch} \end{aligned}$$

The formula to find the chordal tooth thickness is

$$t_c = PD \sin \left( \frac{90^\circ}{NT} \right)$$

For example,

$$t_c = 3 \times \sin \left( \frac{90^\circ}{NT} \right)$$

$$= 3 \times \sin 3^\circ 45''$$

$$= 3 \times 0.0654$$

$$= 3 \times 0.1962 \text{ inch}$$

**(NOTE:** *Mathematics*, Volume II-A, NAVEDTRA 10062, and various machinist's handbooks contain information on trigonometric functions.)

Now set the vertical scale of the gear tooth vernier caliper to 0.128 inch. Adjust the caliper so the jaws touch each side of the tooth as shown in figure 14-3. If the reading on the horizontal scale is 0.1962 inch, the tooth has correct dimensions; if the dimension is greater, the whole depth (WD) is too shallow; if the reading is less, the whole depth (WD) is too deep.

Sometimes you cannot determine the outside diameter of a gear or the number of teeth from available information. However, if you can find a gear dimension and a tooth dimension, you can put these dimensions into one or more of the formulas in Appendix II and calculate the required dimensions.

## MACHINING THE GEAR

Use the following procedures to make a gear with the dimensions given in the preceding example:

1. Select and cut a piece of stock to make the blank. Allow at least 1/8 inch excess material on the diameter and thickness of the blank for cleanup cuts.
2. Mount the stock in a chuck on a lathe. At the center of the blank, face an area slightly larger than the diameter of the required bore.

3. Drill and bore to the required size (within tolerance).
4. Remove the blank from the lathe and press it on a mandrel.
5. Set up the mandrel on the milling machine between the centers of the index head and the footstock. Dial in within tolerance.
7. Select a No. 5 involute gear cutter (8 pitch) and mount and center it.
8. Set the index head to index 24 divisions.
9. Start the milling machine spindle and move the table up until the cutter just touches the gear blank. Set the micrometer collar on the vertical feed handwheel to zero, then hand feed the table up toward the cutter slightly less than the whole depth of the tooth.
10. Cut one tooth groove. Then index the workpiece for one division and take another cut. Check the tooth dimensions with a vernier gear tooth caliper as described previously. Make the required adjustments to provide an accurately "sized" tooth.
11. Continue indexing and cutting until the teeth are cut around the circumference of the workpiece.

When you machine a rack, space the teeth by moving the work table an amount equal to the circular pitch of the gear for each tooth cut. Calculate the circular pitch by dividing 3.1416 by the diametral pitch:

$$CP = \frac{3.1416}{DP}$$

You do not need to make calculations for corrected addendum and chordal pitch to check rack teeth dimensions. On racks the addendum is a straight line dimension and the tooth thickness is one-half the linear pitch.

## HELICAL GEARS

A helix is a line that spirals around a cylindrical object, like a stripe that spirals around a barber pole.

A helical gear is a gear whose teeth spiral around the gear body. Helical gears transmit motion from one shaft to another. The shafts can be either parallel or set

Deleted—No permission  
granted for electronic copy.

**Figure 14-4.—Helical gears.**

at an angle to each other, as long as their axes do not intersect (fig. 14-4).

Helical gears operate more quietly and smoothly than spur gears because of the sliding action of the spiral teeth as they mesh. Also, several teeth make contact at the same time. This multitooth contact makes a helical gear stronger than a comparable spur gear. However, the sliding action of one tooth on another creates friction that could generate excessive heat and wear. Thus, helical gears are usually run in an oil bath.

A helical gear can be either right-handed or left-handed. To determine the hand of a helical gear, simply put the gear on a table with its rotational axis perpendicular to the table top. If the helix moves upward

toward the right, the gear is right-handed. If the helix moves upward to the left, the gear is left-handed.

To mill a helical gear, you need a dividing head, a tailstock, and a lead driving mechanism for the dividing head (fig. 14-5). These cause the gear blank to rotate at a constant rate as the cut advances. This equipment is an integral part of a universal knee and column type of milling machine.

When a helical gear is manufactured correctly, it will mesh with a spur gear of the same diametral pitch (DP), with one gear sitting at an angle to the other. The dimensions of a helical gear would be the same as those of a comparable spur gear if the helical gear's teeth were

Deleted—No permission  
granted for electronic copy.

**Figure 14-5.—A universal horizontal milling machine equipped for helical milling. The closeup shows the workpiece mounted between the dividing head centers. A fluting cutter is mounted on the arbor.**

$$\text{Sec } 19^{\circ}22' = \frac{\text{HYPOTENOUS}}{\text{ADJACENT}}$$

$$\text{Sec } 19^{\circ}22' = \frac{X}{250}$$

$$106 = \frac{X}{250}$$

$$X = 106 \times 250$$

$$X = 265$$

$$265 \times 40 = \text{SIZE OF CIRCLE}$$

$$106 = \text{SIZE OF CIRCLE } 250$$

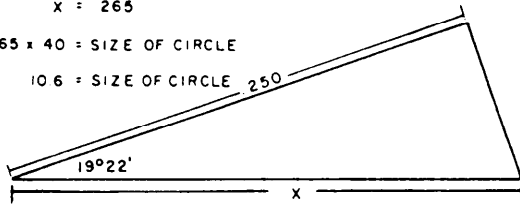


Figure 14-6.—Development of evenly spaced slots with an included angle.

not cut at an angle. One of these differences is shown in the following example:

You will need a 10-inch circular blank to cut 20 one-quarter-inch wide slots spaced one-quarter of an inch apart parallel to the gear's axis of rotation. But you will need a 10.6-inch circular blank to cut the same slots at an angle of  $19^{\circ}22'$  to the axis of rotation (fig. 14-6).

Helical gears are measured at a right angle to the tooth face in the same manner as spur gears with the same diametral pitch.

## DIMENSIONS OF A HELICAL GEAR, REAL AND NORMAL

Every helical gear contains a theoretical spur gear. Any gear element formula used to calculate a spur gear dimension can also be used to determine an equivalent helical gear dimension. However, the helical gear dimension is known as a normal dimension. For example, the number of teeth (NT) on a helical gear is considered a normal dimension. Remember, though, all normal gear elements are calculated dimensions and therefore cannot be measured.

For example:  $\frac{NT}{DP} = \text{Normal pitch diameter (NPD)}$

Although most helical gear dimensions are normal dimensions, a few dimensions are real (measurable) dimensions. Examples of real dimensions are the outside diameter (OD), called the real outside diameter (ROD), and the pitch diameter, called the real pitch diameter (RPD). Two other real dimensions are the lead and the helix angle ( $\angle H$ ).

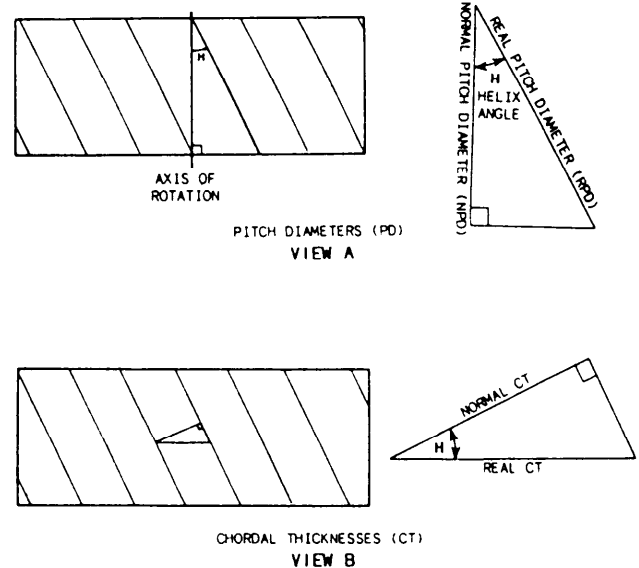


Figure 14-7.—Development of the helix angle.

The lead of a helical gear is the longitudinal distance a point on the gear travels during one complete revolution of the gear. During the gear manufacturing process, lead relates to the travel of the table.

The helix angle is the angle between a plane parallel to the rotational axis of the workpiece and the helix line generated on the workpiece. Use this angle to set the milling machine table to cut the gear. Also use it to establish the relationships between the real dimensions and the normal dimensions on a helical gear.

## Determining the Dimensions of a Helical Gear

The RPD is the easiest helical gear dimension to determine. Simply subtract twice the addendum from the ROD, or

$$RPD = ROD - 2 ADD$$

To determine the other major dimensions, you must relate real and normal dimensions trigonometrically through the helix angle. Then by knowing two of the three components of the trigonometric relationship, you can determine the third component.

Look at figure 14-7, view A, and recall that the helix angle is the angle between the gear's axis of rotation and the helix. In this view, the RPD and the NPD are related through the secant and cosine functions. That is,

$$\text{Secant } H = \frac{RPD}{NPD} \text{ or } \text{Cosine } H = \frac{NPD}{RPD}$$

In figure 14-7, view B, the triangle has been mathematically shifted so we can compare the real chordal thickness (CTR) and the normal chordal

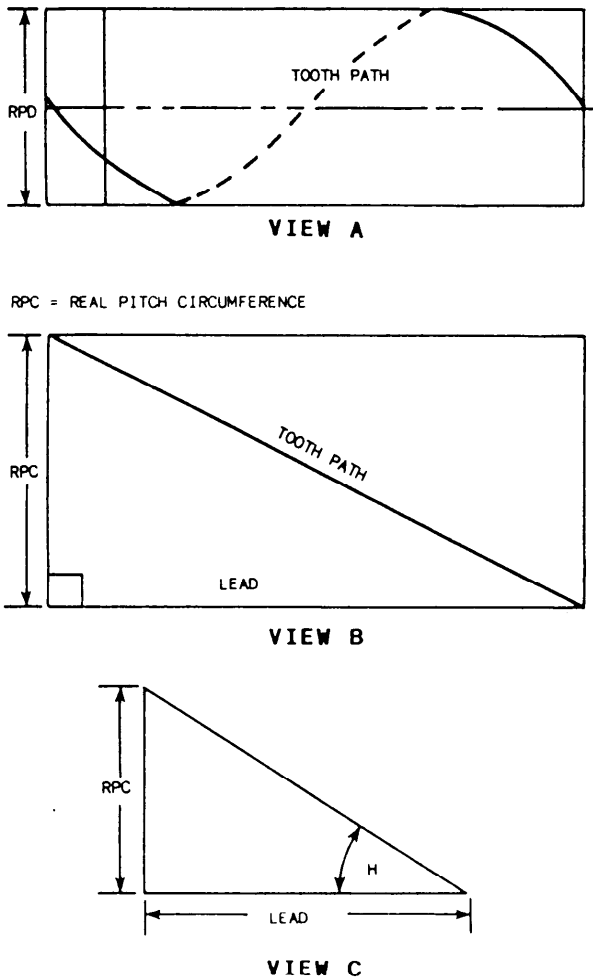


Figure 14-8.—Formulation of a lead triangle and a helix angle.

thickness (CTN). The CTR is the thickness of the tooth measured parallel to the gear's face, while the CTN is measured at a right angle to the face of the tooth. The two dimensions are also related through the secant and cosine functions. That is,

$$\text{Secant } H = \frac{CTR}{CTN} \text{ or } \text{Cosine } H = \frac{CTN}{CTR}$$

If we could open the gear on the pitch diameter (PD), we would have a triangle we could use to solve for the lead (fig. 14-8, view A).

Figure 14-8, view B, shows a triangle; one leg is the real pitch circumference and the other is the lead. Notice that the hypotenuse of the triangle is the tooth path and has no numerical value.

To solve for the lead of a helical gear, when you know the RPD and the helix angle, simply change RPD to RPC (real pitch circumference). To do that, multiply RPD by 3.1416 ( $\pi$ ) (fig. 14-8, view C), then use the formula:

$$\text{Lead} = \text{RPC} \times \text{Cotangent } \angle H.$$

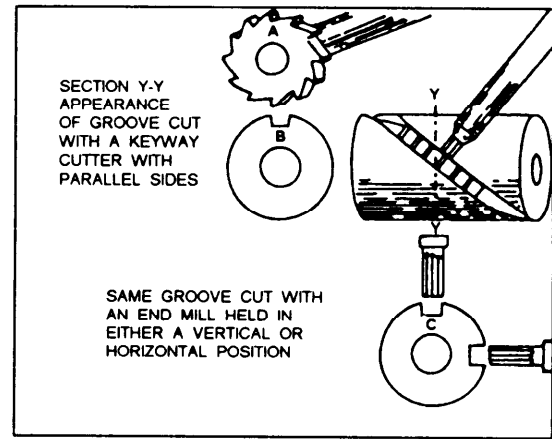


Figure 14-9.—Helix cut with two different cutters.

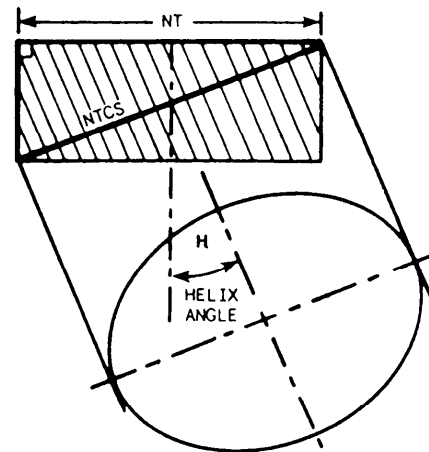


Figure 14-10.—Formation of helical gear cutter selection.

### Selecting a Helical Gear Cutter

When you cut a spur gear, you base selection of the cutter on the gear's DP and on the NT to be cut. To cut a helical gear, you must base cutter selection on the helical gear's DP and on a hypothetical number of teeth set at a right angle to the tooth path. This hypothetical number of teeth takes into account the helix angle and the lead of the helix, and is known as the number of teeth for cutter selection (NTCS). This hypothetical development is based on the fact that the cutter follows an elliptical path as it cuts the teeth (fig. 14-9).

The basic formula to determine the NTCS involves multiplying the actual NT on the helical gear by the cube of the secant of the helix angle, or

$$NTCS = NT \times \text{sec } \angle H^3$$

This formula is taken from the triangle in figure 14-10.

Table 14-1.—"K" Factor Table

Degrees of Helix Angle	K	Degrees of Helix Angle	K	Degrees of Helix Angle	K
1	1.001	22	1.254	43	2.557
2	1.002	23	1.282	44	2.687
3	1.004	24	1.312	45	2.828
4	1.007	25	1.344	46	2.983
5	1.011	26	1.377	47	3.152
6	1.016	27	1.414	48	3.336
7	1.022	28	1.454	49	3.540
8	1.030	29	1.495	50	3.767
9	1.038	30	1.540	51	4.012
10	1.047	31	1.588	52	4.284
11	1.057	32	1.640	53	4.586
12	1.068	33	1.695	54	4.925
13	1.080	34	1.755	55	5.295
14	1.094	35	1.819	56	5.710
15	1.110	36	1.889	57	6.190
16	1.127	37	1.963	58	6.720
17	1.145	38	2.044	59	7.321
18	1.163	39	2.130	60	8.000
19	1.182	40	2.225	61	8.780
20	1.204	41	2.326	62	9.658
21	1.228	42	2.436	63	10.687

Table 14-2.—Corrected Tooth Constant

No. of Teeth	Chordal Thickness	Chordal Addenda	No. of Teeth	Chordal Thickness	Chordal Addenda	No. of Teeth	Chordal Thickness	Chordal Addenda
10	1.56434	1.06156	59	1.57061	1.01046	108	1.57074	1.00570
11	1.56546	1.05598	60	1.57062	1.01029	109	1.57075	1.00565
12	1.56631	1.05133	61	1.57062	1.01011	110	1.57075	1.00560
13	1.56698	1.04739	62	1.57063	1.00994	111	1.57075	1.00556
14	1.56750	1.04401	63	1.57063	1.00978	112	1.57075	1.00551
15	1.56794	1.04109	64	1.57064	1.00963	118	1.57075	1.00546
16	1.56827	1.03852	65	1.57064	1.00947	114	1.57075	1.00541
17	1.56856	1.03625	66	1.57065	1.00933	115	1.57075	1.00537
18	1.56880	1.03425	67	1.57065	1.00920	116	1.57075	1.00533
19	1.56901	1.03244	68	1.57066	1.00907	117	1.57075	1.00529
20	1.56918	1.03083	69	1.57066	1.00893	118	1.57075	1.00524
21	1.56933	1.02936	70	1.57067	1.00880	119	1.57075	1.00519
22	1.56946	1.02803	71	1.57067	1.00867	120	1.57075	1.00515
23	1.56958	1.02681	72	1.57067	1.00855	121	1.57075	1.00511
24	1.56967	1.02569	73	1.57068	1.00843	122	1.57075	1.00507
25	1.56977	1.02466	74	1.57068	1.00832	123	1.57076	1.00503
26	1.56984	1.02371	75	1.57068	1.00821	124	1.57076	1.00499
27	1.56991	1.02284	76	1.57069	1.00810	125	1.57076	1.00495
28	1.56998	1.02202	77	1.57069	1.00799	126	1.57076	1.00491
29	1.57003	1.02127	78	1.57069	1.00789	127	1.57076	1.00487
30	1.57008	1.02055	79	1.57069	1.00780	128	1.57076	1.00483
31	1.57012	1.01990	80	1.57070	1.00772	129	1.57076	1.00479
32	1.57016	1.01926	81	1.57070	1.00762	130	1.57076	1.00475
33	1.57019	1.01869	82	1.57070	1.00752	131	1.57076	1.00472
34	1.57024	1.01813	83	1.57070	1.00743	132	1.57076	1.00469
35	1.57027	1.01762	84	1.57071	1.00734	133	1.57076	1.00466
36	1.57030	1.01714	85	1.57071	1.00725	134	1.57076	1.00462
37	1.57032	1.01667	86	1.57071	1.00716	135	1.57076	1.00457
38	1.57035	1.01623	87	1.57071	1.00708	136	1.57076	1.00454
39	1.57037	1.01582	88	1.57071	1.00700	137	1.57076	1.00451
40	1.57039	1.01542	89	1.57072	1.00693	138	1.57076	1.00447
41	1.57041	1.01504	90	1.57072	1.00686	139	1.57076	1.00444
42	1.57043	1.01469	91	1.57072	1.00679	140	1.57076	1.00441
43	1.57045	1.01434	92	1.57072	1.00672	141	1.57076	1.00439
44	1.57047	1.01402	93	1.57072	1.00665	142	1.57076	1.00435
45	1.57048	1.01370	94	1.57072	1.00658	143	1.57076	1.00432
46	1.57050	1.01341	95	1.57073	1.00651	144	1.57076	1.00429
47	1.57051	1.01311	96	1.57073	1.00644	145	1.57077	1.00425
48	1.57052	1.01285	97	1.57073	1.00637	146	1.57077	1.00422
49	1.57053	1.01258	98	1.57073	1.00630	147	1.57077	1.00419
50	1.57054	1.01233	99	1.57073	1.00623	148	1.57077	1.00416
51	1.57055	1.01209	100	1.57073	1.00617	149	1.57077	1.00413
52	1.57056	1.01187	101	1.57074	1.00611	150	1.57077	1.00411
53	1.57057	1.01165	102	1.57074	1.00605	151	1.57077	1.00409
54	1.57058	1.01143	103	1.57074	1.00599	152	1.57077	1.00407
55	1.57058	1.01121	104	1.57074	1.00593	153	1.57077	1.00405
56	1.57059	1.01102	105	1.57074	1.00587	154	1.57077	1.00402
57	1.57060	1.01083	106	1.57074	1.00581	155	1.57077	1.00400
58	1.57061	1.01064	107	1.57074	1.00575	156	1.57077	1.00397

It can be complicated to compute the NTCS with the formula, so table 14-1 provides the data for a simplified method to cube the secant of the helix angle. To use it, multiply the NT by a factor (K) you obtain from the table.

$$NTCS = NT \times K \text{ (factor)}$$

To determine the constant K, locate on table 14-1 the helix angle you plan to cut. If the angle is other than a whole number, such as 15°6', select the next highest whole number of degrees, in this case 16°. The factor for 15°6' is 1.127.

The following section will show you how to use the numerical value of the NTCS to compute corrected chordal addenda and chordal thicknesses.

### Corrected Chordal Addendum and Chordal Thickness

As in spur gearing, you must determine corrected chordal addenda and chordal thicknesses since you will be measuring circular distances with a gear tooth vernier caliper that was designed to measure only straight distances.

In helical gearing, use the NTCS rather than the actual NT to select the constant needed to determine the chordal addendum (CA) and the chordal thickness (CT). Table 14-2 provides these constants. Remember, the numbers listed in the Number of Teeth column are not actual numbers of teeth, but are NTCS values. After you have determined the chordal addendum and chordal thickness constants, you can calculate the corrected chordal addendum by using the following formula:

$$CADD = \frac{\text{Chordal addendum constant}}{\text{Diametral pitch}} = \frac{CA \text{ constant}}{DP}$$

and the corrected chordal thickness by using this formula:

$$CCT = \frac{\text{Chordal thickness constant}}{\text{Diametral pitch}} = \frac{CT \text{ constant}}{DP}$$

As an example, calculate the corrected chordal addendum and the corrected chordal thickness for a helical gear with a DP of 10, a helix angle of 15°, and 20 teeth.

$$\begin{aligned} NTCS &= NT \times K \\ &= 20 \times 1.11 \text{ (constant from table 14-1)} \\ &= 23 \end{aligned}$$

Table 14-3.—Maximum Backlash Allowance

<u>DP</u>	<u>Backlash</u>
4	.011
5	.009
6	.008
7	.007
8	.006
9	.006
10	.005
12	.005
14	.005

#### A. Maximum Backlash Allowance for Spur and Helical Gear.

<u>DP</u>	<u>Backlash</u>
4	.012
5	.012
6	.008
7	.008
8	.007
10	.007
12	.004
14	.004

#### B. Maximum Backlash Allowance for Bevel Gear.

**NOTE:** If the calculated NTCS is other than a whole number, go to the next highest whole number.

From table 14-2, an NTCS of 23 provides the following:

$$CA \text{ constant} = 1.0268; CT \text{ constant} = 1.56958$$

Therefore,  $CADD = \frac{1.0268}{10} = 0.102680$  and

$$CCT = \frac{1.56958}{10} = 0.156958$$

### Backlash Allowance for Helical Gears

The backlash allowance for helical gears is the same as that for spur gears. Backlash is obtained by decreasing the thickness of the tooth at the pitch line and should be indicated by a chordal dimension. Table 14-3 gives maximum allowable backlash in inches between the teeth of the mating gears.

To determine the proper amount of backlash, multiply the maximum allowable amount of backlash found in table 14-3, part A, by 2 and add the result to the calculated whole depth. In this case the maximum backlash allowance is a constant.



Deleted—No permission  
granted for electronic copy.

**Figure 14-11.—Standard universal dividing head driving mechanism connected to the dividing head, and showing the location of change gears's A, B, C, and D.**

### Center-to-Center Distance

We said earlier in this chapter that the main purpose of gearing is to transmit motion between two or more shafts. In most cases these shafts are in fixed positions with little or no adjustments available. Therefore, it is important for you to know the center-to-center (C-C) distance between the gear and the pinion.

If you know the tooth elements of a helical gear, you can say that when the real pitch radius of the gear ( $RPR_g$ ) is added to the real pitch radius of the pinion ( $RPR_p$ ), you can determine the C-C distance of the two gears (gear and pinion).

The ratio of the NT on the gear and the pinion is equal to the ratio of the PD of the gear and the pinion. This will allow you to solve for the necessary elements of both gear and the pinion by knowing only the C-C distance and the ratio of the gear and the pinion.

### GEAR TRAIN RATIO

When a helix is milled on a workpiece, the workpiece must be made to rotate at the same time it is fed into the revolving cutter. This is done by gearing the dividing head to the milling machine table screw. To achieve a given lead, you must select gears with a ratio that will cause the work to rotate at a given speed while it advances a given distance toward the cutter. This distance will be the lead of the helical gear. The lead of the helix is determined by the size and the placement of the change gears, labeled A, B, C, and D in figure 14-11. Gears X and Y are set up to mill a left-handed helix. You can set a right-handed helix by removing gear Y and reversing gear X.

Before you can determine which gears are required to obtain a given lead, you must know the lead of the milling machine. The lead is the distance the milling

machine table must move to rotate the spindle of the dividing head one revolution. Most milling machines have a table screw of 4 threads per inch with a lead of 0.250 inch (1/4 inch) and a dividing head (index head) with a 40:1 worm-to-spindle ratio. When the index head is connected to the table through a 1:1 ratio, it will cut a lead of 10 inches. Thus, 40 turns of the lead screw are required to make the spindle revolve one complete revolution ( $40 \times 0.250 \text{ inch} = 10 \text{ inches}$ ). Therefore, 10 will be the constant in our gear train ratio formula,

All ratios other than 1:1 require modification of the gear train.

From this formula, we can also say that the

$$\frac{\text{Lead of the machine}}{\text{Lead of the helix to be cut}} = \frac{\text{Product of the driving gears tooth numbers}}{\text{Product of the driven gears tooth numbers}}$$

Example:

Determine the change gears required for a lead of 15 inches. Assume the milling machine has a lead of 10 inches.

$$\frac{\text{Lead of machine}}{\text{Lead of helix desired}} = \frac{10}{15} = \frac{\text{Driving gears tooth numbers product}}{\text{Driven gears tooth numbers product}}$$

If you could use a simple gear train (one driving and one driven gear), a 10-tooth gear on the table screw meshed with a 15-tooth gear on the dividing-head worm shaft would produce the 15-inch lead required. However, gears of 10 and 15 teeth are not available, and the drive system is designed for a compound gear train of four gears. Therefore, the fraction 10/15 must be split into two fractions whose product equals 10/15. Do this by factoring as follows:

$$\frac{10}{15} = \frac{5 \times 2}{5 \times 3} = \frac{\text{Driving gears tooth product}}{\text{Driven gears tooth product}}$$

If gears with 5 and 2 teeth were possible, they would be the driving gears, and gears with 5 and 3 teeth would be the driven gears. But since this is not possible, each of the fractions must be expanded by multiplying both the numerator and the denominator by a number that will result in a product that corresponds to the number of teeth on available gears:

$$\frac{5}{5} \times \frac{8}{8} = \frac{40}{40} \text{ and } \frac{2}{3} \times \frac{12}{12} = \frac{24}{36}$$

or

$$\frac{5 \times 2}{5 \times 3} = \frac{40 \times 24}{40 \times 36} = \frac{\text{Driving gears tooth product}}{\text{Driven gears tooth product}}$$

Thus, gears with 40 and 24 teeth become the driving gears, and gears with 40 and 36 teeth become the driven gears.

These gears would be arranged in the gear train as follows:

Gear A (on the dividing-head worm shaft)

40 teeth (driven)

Gear B (first gear on the idler stud)

24 teeth (driving)

Gear C (second gear on the idler stud)

36 teeth (driven)

Gear D (gear on the table screw)

40 teeth (driving)

The positions of the driving gears may be interchanged without changing their products. The same is true of the driven gears. Thus, several different combinations of driving and driven gears will produce a helix with the same lead.

Before you start to figure your change gear, check your office library for a ready-made table for the selection of gears devised by the Cincinnati Milling Machine Company. These gears have been determined using the formula,  $\frac{\text{lead}}{10}$ . If you have already calculated your lead, match it with the lead in the table and select the gears for that lead.

## MANUFACTURING A HELICAL GEAR

At this point of the chapter, you are ready to manufacture a helical gear. In a case where you must manufacture a helical gear from a sample, you should do the following:

1. Find the DP.
2. Measure the OD. This is also the ROD.
3. Find the ADD.
4. Find the RPD.
5. Find the NT.

6. Find the NPD.
7. Find the  $\angle H$ .
8. Find the RPC.
9. Find the lead.
10. Find the change gear.
11. Find the NTCS.
12. Make sure the cutter has the correct DP and cutter number.
13. Find your corrected chordal addendum and chordal thickness.
14. Find your corrected whole depth (WD).
15. Determine what kind of material the sample gear is to be made of.

Now you are ready to machine your gear.

Use the following hints to manufacture a helical gear:

1. Make all necessary calculations that are needed to compute the dimensions of the gear.
2. Set up the milling machine attachments for machining.
3. Select and mount a gear cutter. Use the formula

$$\text{Sec } \angle H^3 = \frac{NTCS(X)}{NT}$$

4. Swivel the milling machine table to the helix angle for a right-hand helix; face the machine and push the milling machine table with your right hand. For a left-hand helix, push the table with your left hand.

5. Set the milling machine for the proper feeds and speeds.
6. Mount the change gears. Use the gear train ratio formula to determine your change gears.

7. Mount the gear blank for machining.
8. Set up the indexing head for the correct number of divisions.

9. Before cutting the teeth to the proper depth, double check the setup, the alignment, and all calculations.

10. Now you are ready to cut your gear.
11. Remove and deburr the gear.

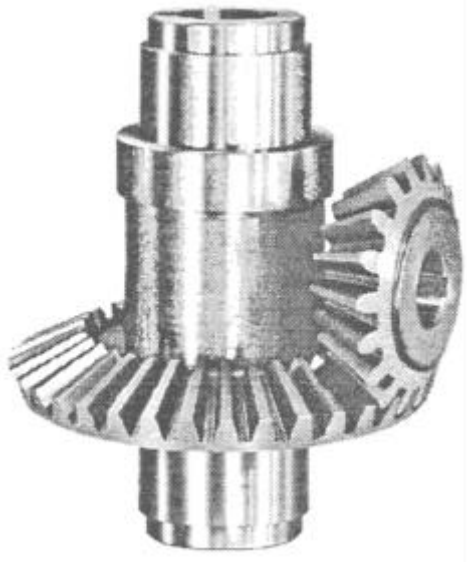
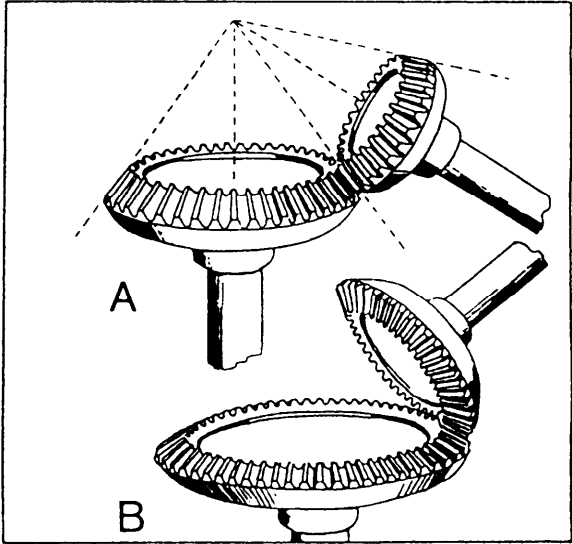


Figure 14-12.—Bevel gear and pinion.



A. With shafts less than 90° apart  
 B. With shafts more than 90° apart

Figure 14-13.—Other forms of bevel gears.

**BEVEL GEARS**

Bevel gears have a conical shape (fig. 14-12) and are used to connect intersecting shafts. Figure 14-13, view A, shows an example of bevel gears with shafts set at less than 90°. View B shows those set at more than 90°. There are several kinds of bevel gear designs. We will discuss the straight-tooth design because it is the most commonly used type in the Navy. The teeth are

straight but the sides are tapered. The center line of the teeth will intersect at a given point.

Bevel gears are usually manufactured on gear-cutting machines. However, you will occasionally have to make one on a universal milling machine.

This section of the chapter deals with the angle nomenclature of a bevel gear as well as the development of the triangles needed to manufacture one.

When two bevel gears whose shaft angles equal  $90^\circ$  are in mesh (fig. 14-14, view A) they form a triangle. It is called the mating gear triangle. The cones (fig. 14-14, view B) that form the basis of the bevel gears are called the pitch cones. These cones are not visible at all on the finished gear, but they are important elements in bevel gear design.

The angle that is formed at the lower left-hand corner of the triangle (fig. 14-14, view C) is called the pitch cone angle of the pinion. The altitude of the triangle is called the pitch diameter of the pinion, and its base is called the pitch diameter of the gear.

The hypotenuse of the triangle is twice the pitch cone radius.

The pitch diameter (gear and pinion), the number of teeth (gear and pinion), and the actual ratio between the gear and the pinion are all in ratio. Therefore, we can use any of these three sets to find the pitch cone angle (PCA).

Example: A 10 diametral pitch (DP) gear with 60 teeth has a pitch diameter (PD) of 6 and a 10 DP pinion with 40 teeth has a PD of 4. Therefore, the ratio of the gear and the pinion is 3:2.

We can determine the PCA by simply substituting the known values into the formula:

$$\tan \angle_{PC} = \frac{NT_g}{NT_p} = \frac{(60)}{(90)}$$

or

$$\frac{PD_g}{PD_p} = \frac{(6)}{(4)} = \frac{3}{2} \text{ ratio}$$

**NOTE:** The pitch cone angle of the pinion ( $PCA_p$ ) is the complement of the pitch cone angle of the gear ( $PCA_g$ ).

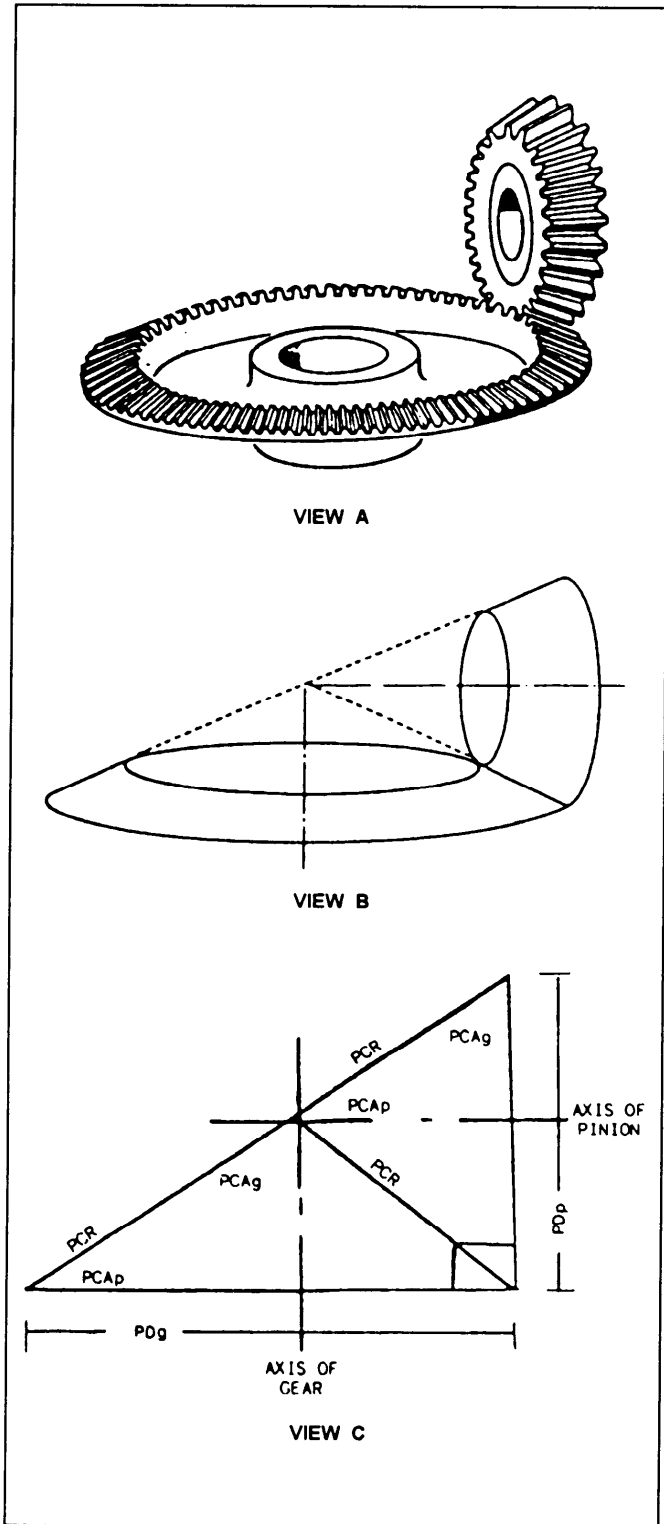
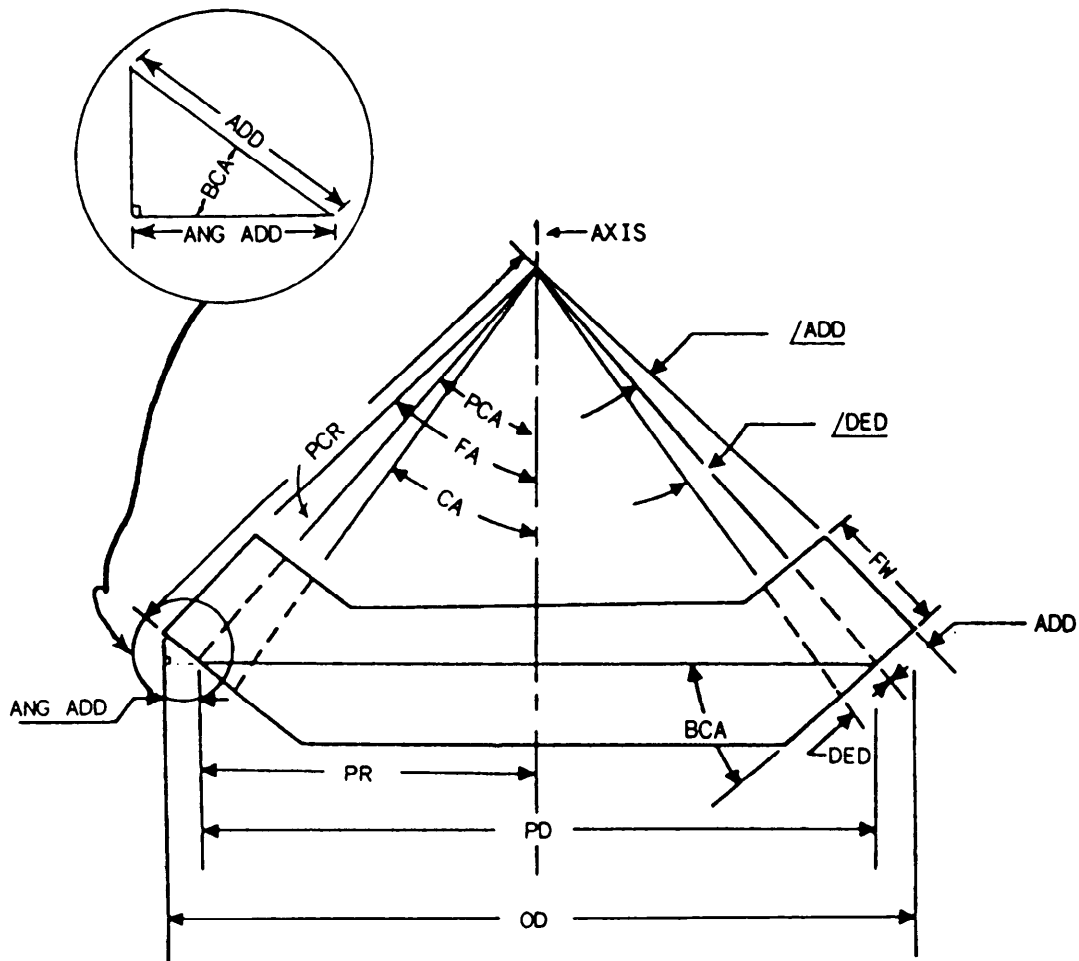


Figure 14-14.—Development of the mating gear triangle.



- |                        |                            |
|------------------------|----------------------------|
| FA - Face angle        | OD - Outside diameter      |
| PCA - Pitch cone angle | ANG ADD - Angular addendum |
| CA - Cutting angle     | FW - Face width            |
| ADD - Addendum angle   | PCR - Pitch cone radius    |
| DED - Dedendum angle   | PR - Pitch radius          |
| BCA - Back cone angle  | ADD - Addendum             |
| PD - Pitch diameter    | DED - Dedendum             |

Figure 14-15.—Parts of a bevel gear.

## BEVEL GEAR NOMENCLATURE

The dimension nomenclature of the bevel gear is the same as that of a spur gear, with the exception of the angular addendum. Refer to figure 14-15.

### 1. Face angle (FA)

- a. This angle is formed by the top edge of the teeth and the axis of the gear.
- b. The gear blank is machined to this angle.
- c. The face angle is obtained by adding one addendum angle ( $\angle ADD$ ) to the pitch cone angle ( $\angle PC$ ).

### 2. Pitch cone angle (PCA or $\angle PC$ )

- a. This angle is formed by a line down one addendum on the tooth and the axis of the gear.
- b. This angle cannot be measured, but it is very important in calculations.

### 3. Cutting angle ( $\angle C$ or CA)

- a. This angle is formed by the bottom of the tooth and the axis of the gear.
- b. The index head is set at this angle when the gear is cut.

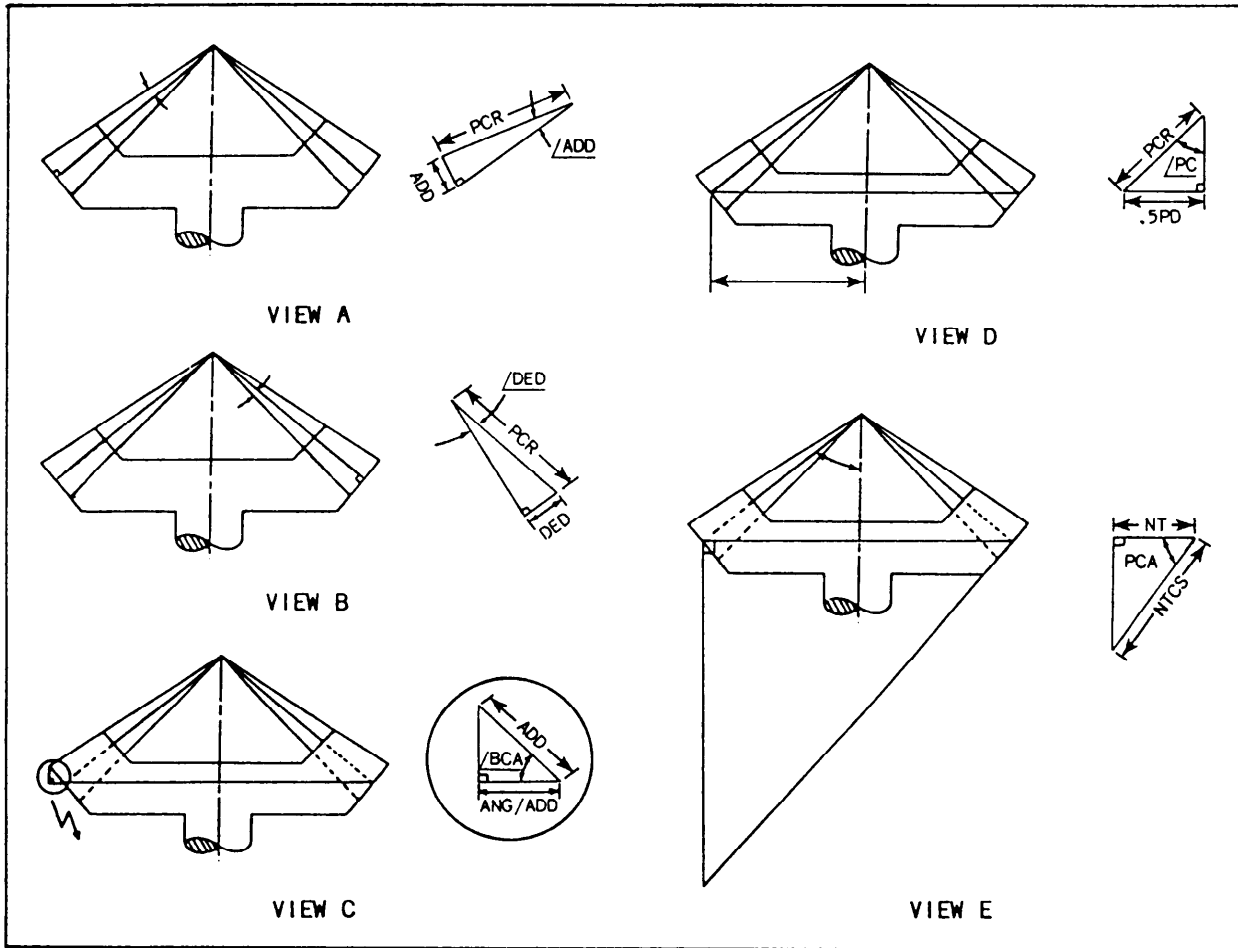


Figure 14-16.—Development of bevel gear formulas.

- c. This angle is obtained by subtracting the dedendum angle ( $\angle DED$ ) from the pitch cone angle ( $\angle PC$ ).

#### 4. Addendum angle ( $\angle ADD$ )

- This angle is formed by the top of the tooth and a line one addendum down on the tooth.
- This angle cannot be measured, but it is used in making calculations for the gear.
- In the triangle shown in figure 14-16, view A, the hypotenuse is the pitch cone radius and the side opposite is the addendum.

$$\text{Therefore, } \cot \angle ADD = \frac{PCR}{ADD}$$

#### 5. Dedendum angle ( $\angle DED$ ) (fig. 14-15)

- This angle is formed by a line addendum down on the tooth and a drawn through the bottom tooth.
- This angle cannot be measured, but used in calculations.
- In the triangle shown in figure 14-16, view B, the side opposite the dedendum angle is the dedendum and the hypotenuse is the pitch cone radius.

$$\text{Therefore, } \cot \angle DED = \frac{PCR}{DED}$$

#### 6. Back cone angle (BCA or $\angle BC$ ) (fig. 14-15).

This angle is formed by the large end of the tooth and the pitch diameter of the gear. It is equal in value to the pitch cone angle (PCA).

7. Pitch diameter (PD)—This is the diameter of the gear blank one addendum down at the large end of the gear.

8. Outside diameter (OD)

- a. This is the maximum diameter of the gear.
- b. The gear blank is machined to this outside diameter.
- c. The outside diameter is obtained by adding the pitch diameter and twice the angular addendum.

9. Angular addendum (ANG ADD)

- a. This is one-half the difference between the pitch diameter and the outside diameter.
- b. In the triangle shown in figure 14-16, view C, the hypotenuse is the addendum and the side adjacent to the angle (BCA) is known as the angular addendum.
- c. To obtain the angular addendum (ANG ADD), simply multiply the addendum of the gear by the cosine of angle BCA.

$$ANG\ ADD = ADD \times \cos \angle BCA$$

10. Tooth dimensions (TD)

- a. All tooth dimensions at the large end are the same as a spur gear of the same DP.
- b. All tooth dimensions at the small end are a percentage of the large end, depending of the face width ratio.

11. Face width (FW) (fig. 14-15)

- a. This is the length of the tooth.
- b. The gear blank is machined to this dimension.

12. Pitch cone radius (PCR)

- a. This is the length of the side of a cone formed by the bevel gear.
- b. This radius is used extensively in calculations.
- c. In the triangle shown in figure 14-16, view D, the hypotenuse is the pitch cone radius and the side opposite the pitch cone angle ( $\angle PC$ ) is equal to one-half the pitch diameter (0.5 PD).

- d. By using our knowledge of trigonometry, we can obtain the PCR by using the cosec of  $\angle PC$  and one-half the pitch diameter.

$$PCR = \operatorname{cosec} \angle PC \times 0.5PD.$$

13. Pitch cone radius small (PCR<sub>s</sub>). This is the difference between the pitch cone radius and the face width.  $PCR_s = PCR - FW$ .

14. Face width ratio (FWR)

- a. This is the ratio of the pitch cone radius and the face width.  $FWR = \frac{PCR}{FW}$ .
- b. The small tooth dimensions are calculated from this ratio.

15. Proportional tooth factor (PTF). This is the ratio between the pitch cone radius small and the pitch cone radius.  $FTF = \frac{PCR_s}{PCR}$ .

16. Small tooth dimensions. Multiply any large tooth dimension by the proportional tooth fraction to find the dimension of the small tooth of the gear or pinion.

17. Number of teeth for cutter selection (NTCS)

- a. In the triangle shown in figure 14-16, view E, the NTCS is the hypotenuse and the side adjacent is the number of teeth of the gear.
- b. The known angle in this case is the pitch cone angle, or the back cone angle.
- c. To obtain the NTCS, simply multiply the secant of  $\angle PC$  by the NT.

$$NTCS = NT \times \operatorname{Sec} \angle PC.$$

- d. The NTCS is taken from the number of teeth on an imaginary spur gear that has a different pitch diameter (PD) than the pitch diameter (PD) of a bevel gear.
- e. When your computation for the NTCS contains a decimal number, round the computation to the next higher whole number.

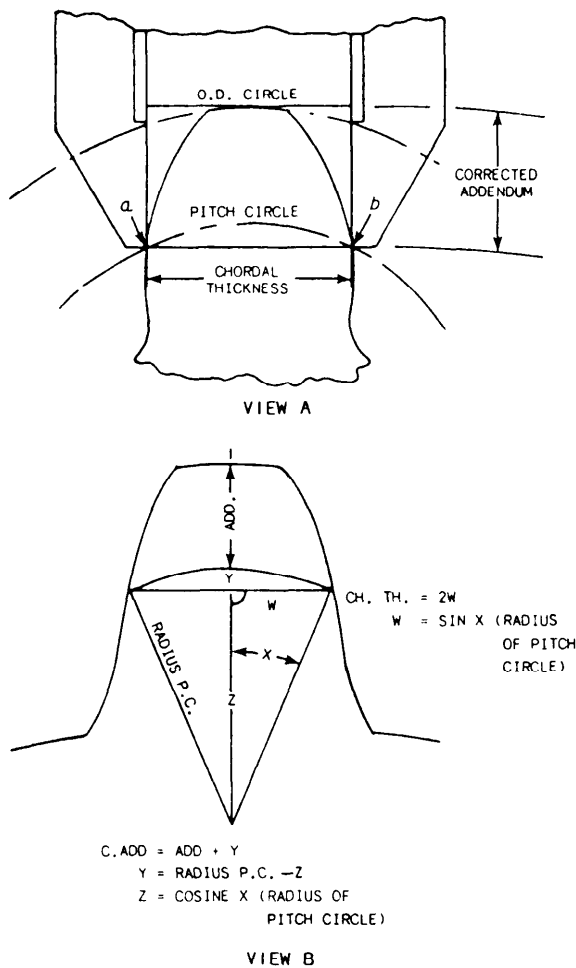


Figure 14-17.—Formulas for calculating chordal thickness.

### Chordal Addendum and Chordal Thickness

Before you can measure a manufactured gear tooth accurately, you must know the chordal addendum and the chordal thickness. These dimensions are used to measure the size of the gear tooth.

Chordal addendum (corrected addendum)  $a_c$ . This is the distance from the top of a gear tooth to the chord across the gear tooth at the pitch circle (fig. 14-17, view A). It is the point at which the chordal thickness is measured.

Chordal thickness of a gear tooth ( $t_c$ ). This is the distance in a straight line (chord) from one side of the tooth to the other side at the points where the pitch circle passes through the gear tooth (fig. 14-17, view A).

Use the following methods to calculate the chordal addendum and the chordal thickness:

You can calculate the dimensions by using the formulas shown in figure 14-17, view B. However, you can also use tables such as table 14-3, part B, to make

bevel gear calculations. Simply substitute the constant into the following formula:

$$\frac{\text{Chordal addendum}}{(a_c) \text{ (large tooth)}} = \frac{\text{Constant} \times \cos \angle PC + 1}{DP}$$

**NOTE:** Obtain the constant from table 14-3, part B.

The procedure used to solve the chordal thickness of the large tooth of a bevel gear is the same as that for a spur gear.

$$\text{Chordal thickness } (t_c) \text{ (large tooth)} = \frac{\text{Constant}}{DP}$$

To determine the chordal addendum (corrected addendum)  $a_c$  small and the chordal thickness of the small tooth, multiply the value of the large tooth by the proportional tooth factor (PTF).

### Backlash Allowance of a Bevel Gear

You learned earlier that backlash is the amount by which the width of a gear tooth space, when two gears are meshed together, exceeds the thickness of the engaging tooth on the pitch circles. You must take these measurements with a device used for that purpose.

Theoretically, when gear teeth are meshed, they should run with little backlash. However, manufacturing tolerances make this impossible. There must be space between the gear teeth for lubrication and for expansion due to temperature changes at high speeds.

Just as with helical gears, bevel gears must have enough freedom between teeth so they will not bind when the gears turn. Table 14-3, part B shows the recommended backlash allowance corresponding to the gear's diametral pitch (DP).

To determine the chordal thickness with backlash at the large end of the tooth, use the following formula:

$$\text{Chordal thickness} = \frac{\text{Constant}}{DP} - \frac{1}{2} \text{ backlash allowance}$$

**NOTE:** Obtain the constant from table 14-3, part B.

To determine the corrected working depth (WD) with backlash at the large end of the tooth, use the following formula:

$$\frac{2.157}{DP} + (2 \times \text{backlash allowance})$$



## SELECTING A BEVEL GEAR CUTTER

To cut bevel gears on the milling machine, you must use special form relieved cutters. These cutters are similar in appearance and size to those used to cut spur gears, but they have thinner teeth. They are made to cut gears with a face width not greater than one-third nor less than one-eighth of the distance from the back of the gear to the apex of the cone.

The contour of the cutter teeth is made for the large end of the gear. The tooth shape at any other section, then, is only an approximation of the current form for that section. However, it is possible to approximate the dimensions and form of the teeth with enough accuracy to meet the repair needs aboard ship.

To get the best results in milling bevel gear teeth, select a cutter, not for the number of teeth in the bevel gear, but for the number of teeth in an imaginary spur gear. This imaginary spur gear has a different diameter than the actual bevel gear.

To determine the number of teeth in the imaginary spur gear, multiply the number of teeth in the actual gear by the secant of the pitch cone angle. That is:

$$NTCS = NT \times \text{Sec } \angle PC$$

Where:

$NTCS$  = number of teeth of the imaginary spur gear

$NT$  = number of teeth in the actual bevel gear

$\angle PC$  = pitch cone angle

Suppose you plan to cut a bevel gear with 30 teeth and a  $45^\circ$  pitch cone angle. Using the NTCS formula, you will find the imaginary spur gear to have 43 teeth.

$$\begin{aligned} NTCS &= NT \times \text{Sec } \angle PC \\ &= 30 \times \text{Sec } 45^\circ \\ &= 30 \times 1.4142 \\ &= 42.4260 \text{ or} \\ &= 43 \end{aligned}$$

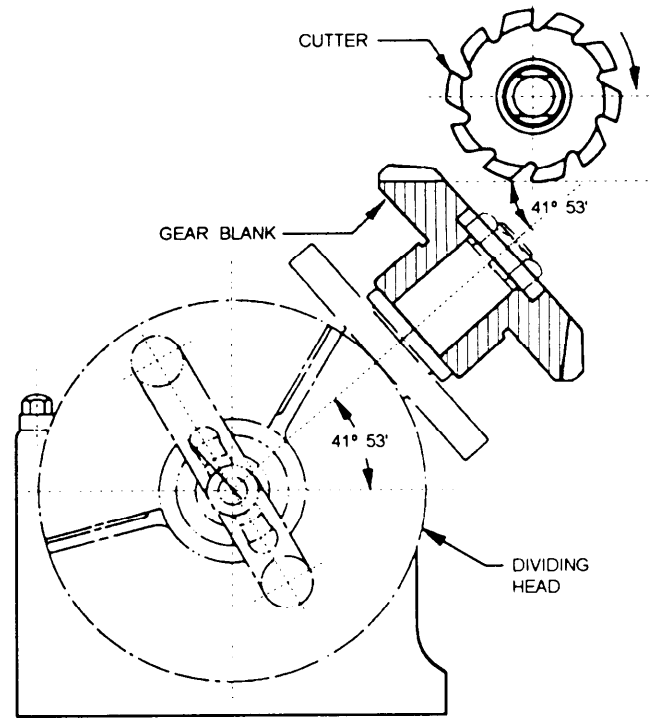


Figure 14-18.—Bevel gear set to the cutting angle by swiveling the dividing head in the vertical plane.

Therefore, by using a standard chart, you can determine the proper cutter for this gear to be a No. 3 cutter with a 6 diametral pitch.

## MILLING THE BEVEL GEAR TEETH

Mount the gear blank in the dividing head with the larger end of the blank toward the dividing head. Set the gear blank to the cutting angle by swiveling the dividing head in the vertical plane (fig. 14-18). To determine the cutting angle, subtract the dedendum angle from the pitch cone angle. The cutting angle is not the same angle as the one to which the gear blank was machined in the lathe.

Milling bevel gear teeth involves three distinct operations. First, gash the teeth into the gear blank, then mill each side of the teeth to the correct tooth thickness.

In the first operation, mount the selected cutter on the milling machine arbor and center the blank on the cutter. Then bring the milling machine table up to cut the whole depth you determined for the large end of the gear. After you cut the first tooth, index the gear blank in the same manner as you would to cut a spur gear, and gash the remaining teeth.

In the second and third operations, mill the sides of the teeth that were formed in the gashing operation.

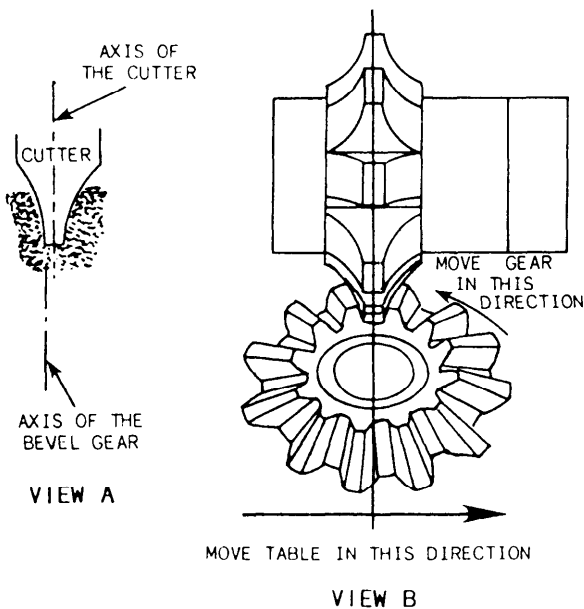


Figure 14-19.—Rolling and offsetting a bevel gear.

When you prepare to cut a bevel gear, remember that the milling machine is the only machine available to you. Therefore, you must take steps like offsetting the cutter (moving the milling machine table a calculated amount) and rolling the gear blank to cut the correct profile on the gear tooth. The following information will help you calculate the amount of offset in inches and the roll of the gear blank in degrees.

### Offsetting The Cutter

To offset the cutter, move it from the axis of the gear blank a calculated distance as shown in figure 14-19, view A. Use the following formula to determine the distance:

$$\text{Offset} = \frac{CTL}{2} - \left( \frac{CTL - CTSC}{2} \times FWR \right)$$

Where:  $CTL$  = tooth thickness, large end

$CTSC$  = tooth thickness, small end

$FWR$  = face width ratio

### Rolling The Gear Blank

After you offset the gear blank, roll it back to the center line of the small end of the tooth by turning the index crank (fig. 14-19, view B). The roll is always in

the opposite direction of the offset. Determine the amount of roll by using the following formula:

$$\text{Roll} = \frac{57.3}{PD} \left[ \frac{CP}{2} - \left( \frac{PCR}{FW} \times CTL - CTSC \right) \right]$$

Where:

57.3 = constant (degrees per radian)

$CTL$  = tooth thickness (cutter), large end

$CTSC$  = tooth thickness (cutter), small end

$CP$  = circular pitch

$PD$  = pitch diameter

$PCR$  = pitch cord radius

$FW$  = width

and the roll is expressed in degrees.

To accomplish the roll, you must know the amount of index crank movement, which you can find with the following formula:

$$NHR = \frac{CR \times NHC}{9^\circ}$$

Where:

$NHR$  = number of holes to roll

$CR$  = calculated roll in degrees

$NHC$  = number of hole circle to index properly

$9^\circ$  (express in degrees—one turn of the index crank)

Use the largest hole circle available when you select your number of hole circles because the largest hole circle has less arc between holes.

After you have milled the bevel gear teeth completely, measure the tooth thickness of the pitch line of both the large and the small ends of the gear. These measurements should be equal to the dimensions you previously determined in your basic calculation. If they are not, check the setup and your calculations to identify your errors.

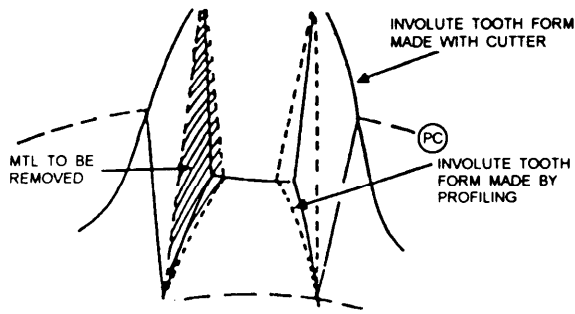


Figure 14-20.—Profiling a bevel gear.

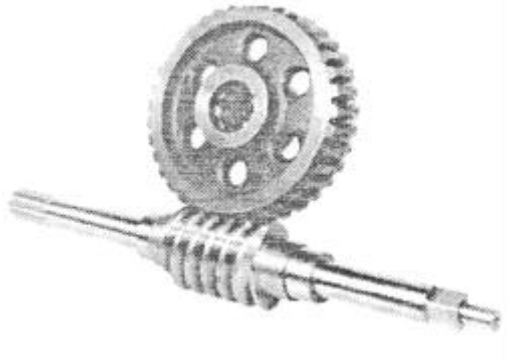


Figure 14-21.—Worm and worm gear.

Remember, you cannot machine a perfect bevel gear in a milling machine. As you learned earlier, you only use part of the cutter's contour when you machine the small end of the tooth. So, to finish the bevel gear teeth properly, you must file the contour as illustrated in figure 14-20. This is known to a Machinery Repairman as profiling the gear.

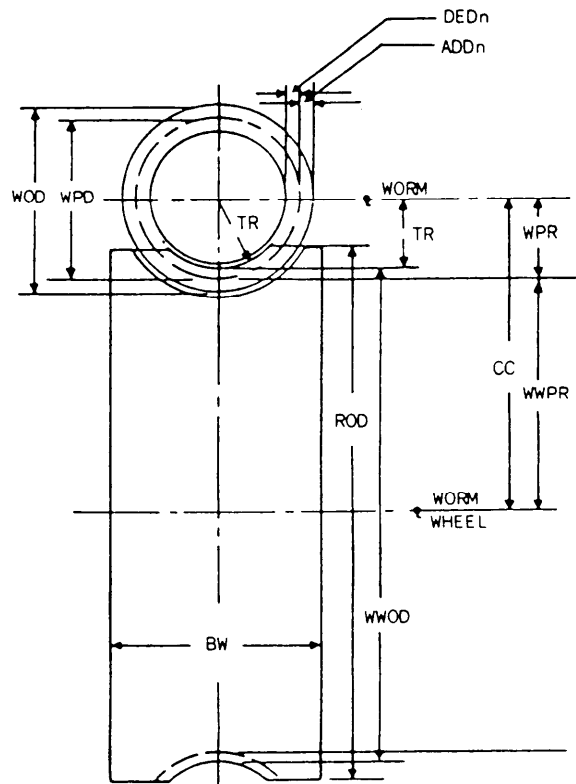
To file a tooth, start at the top of the large end of the tooth and gradually work to the pitch line at the small end.

After you have determined that the gear is properly formed, give the gear a final touch by deburring it.

## WORMS AND WORM GEARS

A worm gear is sometimes called a worm wheel. It has teeth cut at an angle to the axis of rotation and radially in the gear face. The teeth are helical and conform to the helix angle of the teeth on the worm.

Worm gears are used for heavy-duty work where a large reduction of speed is required. They are used extensively in speed reducers.



WOD - Worm outside diameter

WPD - Worm pitch diameter

DEDn - Dedendum

ADDn - Addendum

TR - Throat radius

WPR - Worm pitch radius

CC - Center-to-center distance

ROD - Rim outside diameter

WWOD - Worm wheel outside diameter

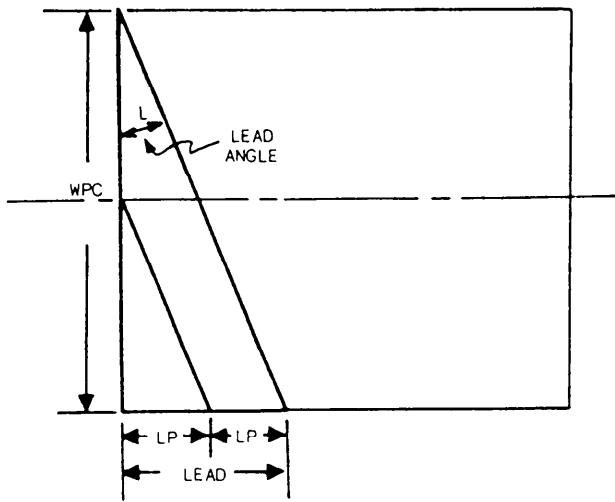
WWPR - Worm wheel pitch radius

BW - Blank width

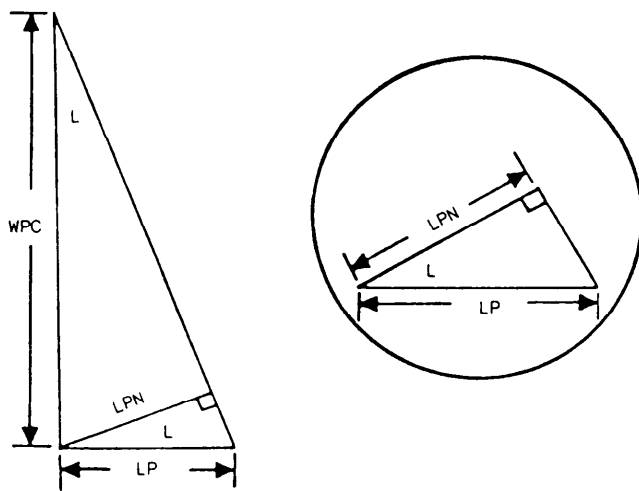
Figure 14-22.—Parts of a worm and worm gear.

A worm, sometimes called a worm thread, resembles an Acme thread. Worms can be either solid or cylinder-type mounted on a shaft. Both are installed perpendicular to the worm gear (fig. 14-21). Worms may have single, double, or triple threads. One revolution of a worm with a single thread turns the circumference of the worm gear an amount equal to the distance between identical points on two adjacent teeth, or one circular pitch, and so on.

This type of gearing is also known as an “endless screw,” where the worm is the driver and the worm gear is driven. Figure 14-22 identifies the parts of a worm and a worm wheel.



VIEW A



VIEW B

Figure 14-23.—Development of lead angle and linear pitch (normal).

## 2. Lead (L)

- a. The distance traveled by a thread during one complete revolution of the worm around its axis.
- b. The lead and the linear pitch are the same on a single-start worm. On a double-start worm, the lead is twice the linear pitch, and on a triple-start worm, the lead is three times the linear pitch.
- c. The number of starts multiplied by the linear pitch equals the lead.

$$\text{No. of } S \times LP = \text{Lead}$$

- d. The lead is needed to determine the proper gear train ratio to set the table travel on the milling machine and to perform work on the lathe machine.

## 3. Lead angle ( $\angle$ )

- a. The angle formed by the thread and a line drawn at a right angle to the axis of the worm.
- b. It can be found by dividing the lead into the worm's pitch circle. The result is the cotangent of the lead angle (fig. 14-23, view A).

$$\text{Therefore: } \text{COT } \angle = \frac{WPC}{\text{Lead}}$$

## WORM AND WORM WHEEL NOMENCLATURE AND FORMULA DEVELOPMENT

You will need the following terms and formulas when you plan and manufacture a worm and a worm wheel:

### 1. Linear pitch (LP)

- a. The distance from a point on one thread to a corresponding point on the next thread.
- b. This distance is measured parallel to the axis of the thread.

### 4. Tooth dimensions

#### a. Linear pitch normal (LPN)

- (1) Measurement of the thread (tooth) at a right angle to its face.
- (2) It can be found by multiplying the linear pitch by the cosine of the lead angle (fig. 14-23, view B).

$$LPN = LP \times \text{COS } \angle$$

- (3) The tooth parts are the same in worm and spur gears.

- b. Use the following formulas to solve for all normal tooth dimensions:

$$\text{Addendum normal} = LPN \times 0.3183$$

$$\text{Clearance normal} = LPN \times 0.0637 \text{ or} \\ ADD_n \times 0.2$$

$$\text{Dedendum normal} = LPN \times 0.382$$

$$\text{Whole depth normal} = LPN \times 0.7$$

$$\text{Circular thickness normal} = LPN \times 0.5$$

**NOTE:** All worm tooth constants are derived from a worm with a 1-inch linear pitch.

#### 5. Length of the worm (LOW)

- a. It is found by using the following formula:

$$LOW = [(NT \times 0.02) + 4.5] \times LP$$

- b. The worm is longer than is required for complete meshing between the worm and the worm wheel.

#### 6. Worm wheel pitch diameter (WWPD)

- a. You learned in spur gearing that for every tooth in the gear there is a circular pitch on the pitch circle, and for every tooth on the gear there is an addendum on the pitch diameter.

- b. By using this theory, we can derive the following formulas:

(1) WWPC D (real)

$$= \frac{NR \times CP \text{ or } (LP)}{\pi}$$

$$= LP \times 0.3183 \times NT$$

(2)  $ADD$  (real) =  $LP \times 0.3183$

#### 7. Throat diameter

- a. It is found by adding the worm wheel pitch diameter and twice the addendum normal.

$$WWPD + 2 ADD_n = \text{Throat diameter}$$

- b. It is measured at the base of the throat radius.

#### 8. Rim diameter

- a. To find the rim diameter for single- and double-start worms, multiply the linear pitch by the constant 0.4775 and add the result of the throat diameter.

$$\text{Rim diameter} = (LP \times 0.4775) + \text{Throat diameter}$$

- b. To find the rim diameter for three or more starts, multiply the linear pitch by the constant 0.3183 and add the result to the throat diameter.

$$\text{Rim diameter} = (LP \times 0.3183) + \text{Throat diameter}$$

#### 9. Throat radius

- a. To find this radius, subtract one addendum (normal) from the pitch radius of the worm.

$$\text{Throat radius} = \text{pitch radius (worm)} - 1 ADD_n$$

- b. This dimension is taken from the worm but is machined on the worm wheel blank.

#### 10. Blank width

- a. To find the blank width for single- and double-start worms, multiply the linear pitch by the constant 2.38 and add the result to the constant 0.250.

$$\text{Blank width} = (LP \times 2.38) + 0.250$$

- b. To find the blank width for three or more starts, multiply the linear pitch by the constant 2.15 and add the result to the constant 0.20.

$$\text{Blank width (for three or more starts)} \\ = LP \times 2.15 + 0.20$$

11. Tooth dimensions. These are the same as those of the worm. The linear pitch and the circular pitch are of equal value.

12. Number of teeth (NT). Multiply the number of starts by the ratio of the worm to the worm wheel.

$$\text{Number of teeth (NT)} = \text{No. of starts} \times \text{ratio of the worm to the worm wheel.}$$

### SELECTING A WORM WHEEL CUTTER

When you machine the throat radius of a worm wheel, select a two- or four-lip end mill with a radius smaller than the calculated throat radius. You need the smaller radius because as you swivel the cutter from its vertical position to a desired angle, the radius being cut increases.

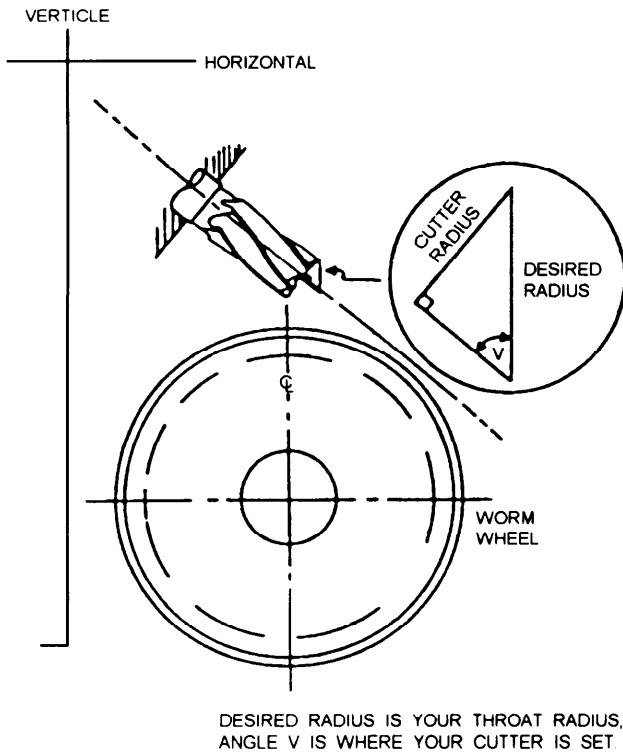


Figure 14-24.—Formation of desired radius.

As you swivel the cutter to a predetermined angle to cut the calculated throat radius, you will form a right triangle (fig. 14-24). Use this triangle to find the radius:

$$\text{Desired radius} = \text{Cutter radius} \times \text{cosec } \angle V$$

Where:

$$\angle V = \text{Angle at which the throat radius is cut.}$$

To determine the depth of cut, subtract the throat diameter from the rim diameter and divide by two.

$$\text{Depth of cut} = \frac{\text{Rim diameter} - \text{Throat diameter}}{2}$$

### CENTER-TO-CENTER DISTANCE (WORM AND WORM WHEEL)

As with other systems of gearing you have studied, worm gearing is designed to transfer motion between two planes at a fixed ratio. The majority of spur and helical gears have adjustments for the center-to-center distance and for backlash. In worm gearing, the center-to-center distance is very important. The worm gearing systems are designed to transfer as much power as possible in the smallest practical space.

This section will give you the information you need to manufacture a worm and a worm wheel using the center-to-center distance and the ratio between the worm (driver) and the worm wheel (driven).

To find the center-to-center distance of a worm and a worm wheel, add the worm pitch radius and the worm wheel pitch radius.

$$C-C = WPR + WWPR, \text{ or}$$

$$C-C = \frac{WPD + WWPD}{2}$$

### WORM WHEEL HOBS

A hob is a cylindrical worm converted into a cutting tool. Hobs resemble worms in appearance and are ideal for cutting a worm wheel. The hob's teeth are cut on the outside of a cylinder following a helical path corresponding to the thread line of a worm. The cutting edges of the hob are formed when flutes are cut into the worm. For small lead angles, flutes are cut parallel to the axis; while for large lead angles ( $6^\circ$  and above), they are cut helically at a right angle to the thread line of the worm.

As a general rule, there should not be a common factor between the number of starts and the number of flutes. Even numbers of starts (6, 8, or 10) should have odd numbers of flutes (7 or 11).

You can usually find the approximate number of gashes (flutes) if you multiply the diameter of the hob by 3 and divide this product by twice the linear pitch.

$$\text{Number of flutes} = \frac{3 \times \text{hob's OD}}{2 \times LP}$$

There are, however, certain modifications you may have to make. The number of gashes (flutes) has a relationship to the number of threads in the hob and to the number of teeth in the worm gear. Try to avoid a common factor between the number of threads and the number of gashes. For example, if the worm is a double-thread worm, the number of gashes should be 7 or 9 rather than 8. If the worm is a triple-thread worm, select 7 or 11 gashes rather than 6 or 9, as both 6 and 9 have a factor in common with 3.

It is also best to avoid having a common factor between the number of threads in the hob and the number of teeth in the worm gear. For example, if the number of teeth is 28, a triple thread will be satisfactory since 3 is not a factor of 28.

Deleted—No permission  
granted for electronic copy.

Figure 14-25.—Milling machine set up for gashing and hobbing of a worm wheel.

The cutter you select to gash the hob should be 1/8 to 1/4 inch thick at the periphery, depending on the pitch of the hob thread. The width of the gash at the periphery of the hob should be about 0.4 times the pitch of the flutes. The depth of the gash should be about 3/16 to 1/4 inch below the root of the thread.

There are three types of hobs:

- Shell. This has a straight bore with a keyway to hold the arbor that drives the hob.
- Straight shank This is the integral part of the shaft. It is used between centers.
- Tapered shank. This has a milling machine taper (Brown and Sharpe). The outside end is supported by either a line or a dead center.

Since the hob is a cutting tool, the top of the tooth on the hob is a dedendum. The bottom of the hob tooth forms the top of the worm wheel tooth and must be given a clearance. Therefore, it also equals a dedendum of the gear you are cutting. The working depth of the hob (cutting portion) is the addendum plus the dedendum of the gear you are cutting.

The nomenclature of the hob is the same as that of the worm; chordal thickness (normal), linear pitch, lead, pressure angle, and pitch diameter. The outside diameter of the hob has two clearances, and both are larger than the worm's outside diameter:

$$WPD + 2 DED$$

Hobs can be bought commercially, or made by a machinist. If you order a hob, furnish drawings or

blueprints of both the worm and the worm wheel and any information such as bore size for the shell-type hob.

### CUTTING WORM WHEEL TEETH ON A MILLING MACHINE

You can cut the teeth of a worm gear on a milling machine, usually in two operations. The first is called gashing the teeth (fig. 14-25, view A). Seat an involute spur-gear cutter of the correct pitch and number according to the number of teeth and pitch of the worm gear. Set the milling machine table at an angle equal to the lead or helix angle of the worm thread. Be sure to center the gear blank under the cutter. To perform the operation, raise the table a distance equal to the whole depth of the tooth. Use the graduated vertical feed dial to get a uniform depth for each tooth. Index each tooth, using the dividing head with a dog clamped to the mandrel to drive the gear blank.

The second operation is called hobbing (fig. 14-25, view B). First, mount the hob on a cutter arbor. Then set the table back to zero, or at a right angle to the machine spindle. Remove the dog so the gear blank can rotate freely. Line up the gear blank so the hob meshes with the gashed slots. When you start the machine, the rotating hob will rotate the gear blank. As the hob and gear blank rotate, raise the table gradually until the teeth are cut to the correct depth. To get the correct center-to-center distance, use the worm that you will use with the worm gear before you remove the worm gear from the milling machine.

## STUB TOOTH GEARS

Stub tooth gears are widely used throughout the automotive industry in transmissions because their great strength enables them to transmit maximum power. Cranes and rock crushers are examples of high-torque equipment that use stub tooth gears. This type of gear has a 20-degree pressure angle and is short and thick. A stub tooth gear compared to other gears has a shorter addendum (ADD). This results in a stronger tooth, but causes the gears to operate with more noise.

Stub tooth gears come in two forms. One form has straight teeth, like spur gears. The other form has teeth similar to those on helical gears. Gears with helically shaped teeth are used when smooth operation is required.

The basic rule for spur, helical, and bevel gears, “for every tooth on the gear, there is a circular pitch (CP) on the pitch circle” also applies to stub tooth gearing systems.

We will discuss two stub tooth gearing systems: the American Standard System and the Fellows Stub Tooth Gears System.

### AMERICAN STANDARD SYSTEM

This system bases tooth dimensions on specific formulas:

1. The tooth depth or whole depth (WD) equals 1.8 divided by the diametral pitch (DP).

$$WD = \frac{1.8}{DP}$$

2. To find the outside diameter (OD), add 1.6 to the number of teeth and then divide by the diametral pitch (DP).

$$OD = \frac{NT + 1.6}{DP}$$

3. To find the addendum (ADD), divide 0.8 by the diametral pitch (DP).

$$ADD = \frac{0.8}{DP}$$

4. To find the clearance (CL), divide 0.2 by the diametral pitch (DP).

$$CL = \frac{0.2}{DP}$$

5. When the addendum (ADD) is added to the clearance (CL) the result is the dedendum (DED).

$$DED = ADD + CL$$

6. All circular measurements of a stub tooth gear, including the number of teeth and the pitch diameter, are the same as those of a spur gear. To find the pitch diameter, divide the number of teeth (NT) by the diametral pitch (DP).

$$PD = \frac{NT}{DP}$$

7. To find the circular pitch (CP), divide ! (3.1416) by the diametral pitch (DP).

$$CP = \frac{3.1416}{DP}$$

8. To find the circular thickness (CT), divide 1.5708 by the diametral pitch (DP).

$$CT = \frac{1.5708}{DP}$$

### FELLOWS STUB TOOTH GEAR SYSTEM

This system was introduced by the Fellows Stub Tooth Gear Company. It uses a 20-degree pressure angle and is based on the use of two diametral pitches (DP). In the formulas we will use, the numerator (DPL) is the circular measurement which consists of the pitch diameter (PD) and the number of teeth (NT). The denominator (DPS) is the radial measurement.

There are eight standard pitches in this system. They are 4/5, 5/7, 6/8, 7/9, 8/10, 9/11, 10/12, and 12/14.

The formulas for the basic dimensions are as follows:

1. *Addendum (ADD)* =  $\frac{1}{DPS}$

2. *Outside diameter (OD)* =  $\frac{NT}{DPL} + \frac{2}{DPS}$

3. *Whole depth (WD)* =  $\frac{2.25}{DPS}$

4. *Clearance (CL)* =  $WD - 2 ADD$

5. *Dedendum (DED)* =  $ADD + CL$

6. *Circular pitch (CP)* =  $\frac{3.1416}{DPL}$

7. *Circular thickness (CT)* =  $\frac{1.5708}{DPL}$

8. *Number of teeth (NT)* =  $DPL \times PD$



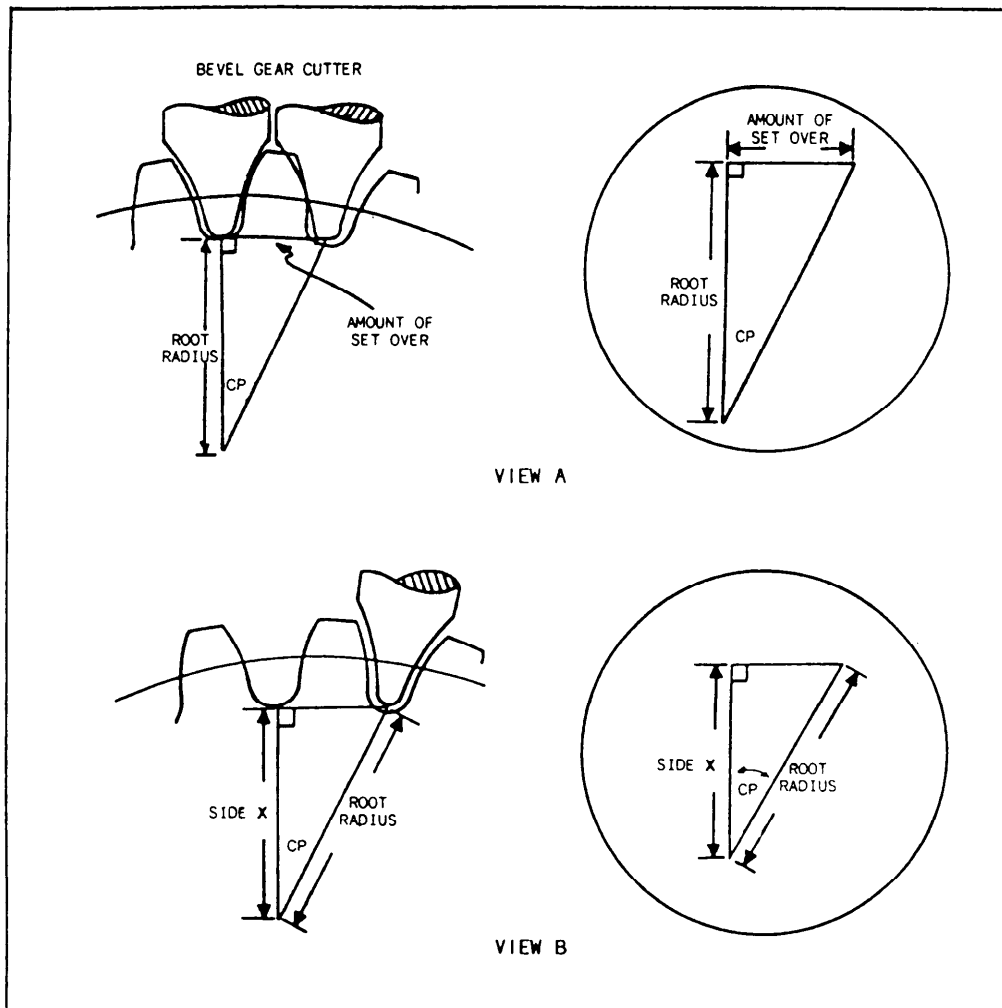


Figure 14-26.—Development of setover and depth increase.

9. Diametral pitch (DP)

$$a. TPL = \frac{NT}{OD - \left(\frac{2}{DPS}\right)}$$

$$b. DPS = \frac{NT}{OD - \left(\frac{NT}{DPL}\right)}$$

### METHOD OF MANUFACTURE

If you buy a stub tooth gear cutter, you can manufacture a straight or helical stub tooth gear by using the procedure you use for spur and helical gears. If you use a fly cutter, use the old gear as a pattern to grind a single-point tool bit to the desired shape.

A properly fitted gear must have a setover and a depth increase. You should calculate these after you

select a cutter. The only way to select a cutter is by sight. Get a large selection of bevel gear cutters, then match one of them to the side of a good tooth.

To find the amount of setover, first establish the circular pitch angle ( $\angle CP$ ). One circular pitch equals  $360^\circ$ . Therefore, you can divide  $360^\circ$  (one circular pitch) by the number of teeth (NT) to find the circular pitch angle ( $\angle CP$ ). You can solve for the amount of setover by using the triangle in figure 14-26, view A.

$$Setover = Root\ radius \times \tan \angle CP$$

Where the root radius is the outside diameter (OD) divided by 2 minus the whole depth (WD).

$$Root\ radius = \frac{OD}{2} - WD$$

To find the amount of depth increase, set up the triangle shown in figure 14-26, view B. In this triangle, side X is equal to the root radius multiplied by the cosine of the circular pitch angle ( $\angle CP$ ).

$$\text{Side } X = \text{Root radius} \times \text{Cos } \angle CP$$

To find the depth increase, subtract side X from the root radius:  $\text{Depth increase} = \text{Root radius} - \text{Side } X$ . The cutting procedure is as follows:

1. Center the cutter on the gear blank.
2. Offset the calculated setover away from the column. The direction of the offset is optional.
3. Move the cutter down to the whole depth of the tooth, plus the calculated amount of depth increase in increments to suit the machine and the setup. Cut the teeth all the way around the blank until one side of the tooth is complete.
4. Move the cutter back to the center line and offset toward the column face the calculated amount of setover. Cut to the full depth of the tooth plus the amount of depth increase. At this time, you are ready to debur your stub tooth gear.

## SPLINES

A splined shaft has a series of parallel keys formed integrally with the shaft. These mate with corresponding grooves cut in a hub or fitting. This is in contrast to a hub or fitting with a series of keys or feathers fitted into slots cut into the shaft. This latter construction weakens the shaft to a considerable degree because of the slots cut into it and, as a consequence, reduces its torque-transmitting capacity.

Splined shafts are generally used in three types of applications: (1) to couple shafts when relatively heavy torques are to be transmitted without slippage; (2) to transmit power to sliding or permanently fixed gears, pulleys, and other rotating members; and (3) to attach parts that may require removal for indexing or a change in angular position.

Splines with straight-sided teeth have been used in many applications. However, the use of splines with involute teeth has increased steadily. Splines with involute teeth are becoming more popular for these reasons: (1) involute spline couplings have greater torque-transmitting capacity than any other type; (2) they can be produced with the same techniques and equipment used to cut gears; and (3) they have a

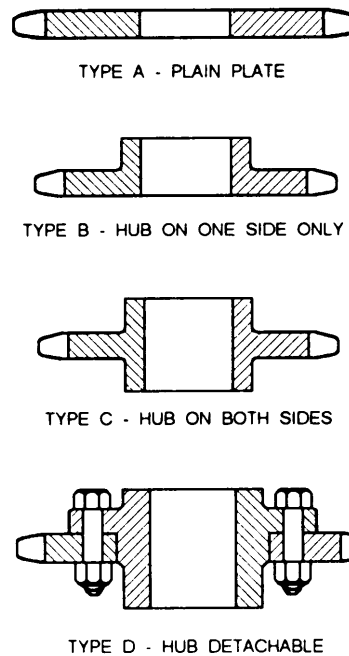


Figure 14-27.—Types of sprockets.

self-centering action under load, even when there is backlash between mating members.

These splines or multiple keys are similar in form to internal and external involute gears. The general practice is to form external splines by hobbing, rolling, or on a gear shaper, and internal splines either by broaching or on a vertical shaper. The internal spline is held to basic dimensions, and the external spline is varied to control the fit. Involute splines have maximum strength at the base; they can be accurately spaced and are self-centering. This equalizes the bearing and stresses, and they can be measured and fitted accurately.

The American National Standard covers involute splines with tooth numbers ranging from 6 to 60 with a 30 or 37.5-degree pressure angle, and from 6 to 100 with a 45-degree pressure angle. When you select the number of teeth for a given spline application, remember these points: (1) There are no advantages in using odd numbers of teeth. (2) The diameters of splines with odd tooth numbers, particularly internal splines, are troublesome to measure with pins since no two spaces are diametrically opposite each other.

## SPROCKETS

Webster's dictionary defines a sprocket wheel as "a wheel with cogs or sprockets to engage with the links of a chain." Most sprockets are one of the four types shown in figure 14-27. The following material briefly

explains the classes and the manufacture of sprocket wheels (called sprockets here). If you want more in-depth information, refer to the current edition of *Machinery's Handbook*.

### **CLASSES OF SPROCKETS**

There are two classes of sprockets; commercial and precision. The choice is a matter of drive application judgment. Commercial sprockets are adequate for the usual moderate to slow speed commercial drive. When you have a combination of extremely high speed and high load, or when the drive involves fixed centers, critical timing, register problems, or close clearance with outside interference, precision sprockets may be more appropriate.

### **MATERIAL FOR SPROCKETS**

Cast iron is commonly used in large sprockets, especially in drives with large speed ratios. It is adequate because the teeth of the larger sprockets are

subject to fewer chain engagements in a given time. For severe service, cast steel or steel plate is preferred.

The smaller sprockets of a drive are usually made of steel. With this material, the body of the sprocket can be heat-treated to produce toughness for shock resistance, and the tooth surfaces can be hardened to resist wear.

Stainless steel or bronze may be used for corrosion resistance; and formica, nylon, or other suitable plastic materials may be used for special applications.

### **MANUFACTURE OF SPROCKETS**

Cast sprockets have cut teeth, and the rim, hub face, and bore are machined. The smaller sprockets are generally cut from steel bar stock and are finished all over. Sprockets are often made from forgings or forged bars, and the finish depends on specifications. Many sprockets are made by welding a steel hub to a steel plate. This process produces a one-piece sprocket of desired proportions and one that can be heat-treated.

## CHAPTER 15

# METALLURGY AND HEAT TREATMENT

### CHAPTER LEARNING OBJECTIVES

*Upon completing this chapter, you should be able to do the following:*

- *Explain the internal structures of metals.*
- *Identify and explain the use of heat-treating equipment.*
- *Explain the principles of heat treating.*
- *Explain the heat treatment of metals.*
- *Identify heat-treating problems.*
- *Identify and explain hardness tests.*

As a Machinery Repairman, you work with many different types of metals and alloys. The more knowledge you have of metals and alloys, the better you will be able to perform your repair and maintenance duties. The information you have already learned about the characteristics of metals and alloys in chapter 3 will help you better understand the theory of metallurgy and heat treatment.

There have been many books written on metallurgy and heat treatment. This chapter will only be an overview. For more detailed information of the theory and of metallurgy and heat treatment, consult a machinist handbook or any textbook on physical metallurgy.

As with any shop equipment you must observe all posted safety precautions. Review your equipment operators manual for safety precautions and any chapters of *Navy Occupational Safety and Health (NAVOSH) Program Manual for Forces Afloat*, OPNAV instruction 5100.19B, which pertain to the equipment you will be operating.

Metallurgy is the art or science of separating metals from their ores, making and compounding alloys, and working or heat-treating metals to give them certain desired shapes or properties. Metallurgy has been broken down into three branches—chemical metallurgy, physical metallurgy, and mechanical metallurgy.

**CHEMICAL METALLURGY** deals with the reduction of metals from their ores and the creation of alloys by changing the chemical structure of the base metals. For example, steel is made from iron, which is produced from iron ore. During this process, coke is used as a fuel, and limestone is used as a fluxing agent.

**PHYSICAL METALLURGY** deals with the nature, structure, and physical properties of metals and alloys. The subject of physical metallurgy includes metallography (study of metals with a microscope), mechanical testing, and heat treatment, which we will discuss later in this chapter.

**MECHANICAL METALLURGY** deals with the working and shaping of metals through operations such as machining, casting, and forging.

### STRUCTURE OF METAL

Throughout your career as a Machinery Repairman, you have become familiar with the physical properties, such as hardness, brittleness, malleability, and ductility, associated with various metals. These properties of metal are directly related to the internal, or atomic, structure of the metals. This section will explain to you how various arrangements of atoms result in these and other properties.

Metals in liquid state have a noncrystalline structural form. The crystals in solid metal are called

**GRAINS** (irregularly shaped crystals developed from the converging lattices). These irregularly shaped crystals are formed as the metal cools and changes from a liquid state to a solid state. This change of state is called **FREEZING** or **SOLIDIFICATION**. As the metal freezes, its atoms lose the energy of motion they had in the metal's liquid state. The slow-moving atoms become attached to one another, usually in one of four predictable patterns, depending on the type and composition of the metal. These patterns are shown in figure 15-1 and will be discussed in greater detail later in this chapter.

## **CRYSTALS AND GRAINS**

The first groups of atoms to form a pattern create what are called **UNIT CELLS**, or **GRAIN NUCLEI**. The unit cell is the basic building block of the metal. Many unit cells connect in the same pattern that makes up the unit cell and forms a **CRYSTAL**. Crystals then connect to form the metal's **CRYSTALLINE STRUCTURE**.

Under ideal conditions, crystals will be perfectly shaped. Under real world conditions, however, crystal shapes are usually distorted. These typically distorted crystals, or grains, form what is known as the **GRAIN STRUCTURE** of the metal.

The surface of a metal does not indicate its internal grain structure. However, when the metal is fractured, structure will show on the fractured surface. The size of the grains depends upon a number of factors, including the nature of the metal, the temperature to which it is heated, the length of time it is held at a specific temperature, and the rate at which it is cooled from a liquid to a solid. In general, the quicker a metal solidifies, the smaller the grains will be.

The line-shaped areas between adjacent grains are known as **GRAIN BOUNDARIES**. A high state of stress exists at the grain boundaries, due to a mismatch of each lattice. When a metal is deformed, the atoms in the structure slide over one another along certain planes called **SLIP PLANES**. Slip planes are the planes of least resistance to an applied force. Metals with large grains have long slip planes, allowing deformation to occur easily. On the other hand, metals with small grains have short slip planes, making deformation difficult. The plane along which a metal separates when subjected to an applied force is called a **CLEAVAGE PLANE**.

**GRAIN SIZE** is determined by the number of grains per square inch in a metal magnified 100 times normal size. The number of grains that form depends upon the

rate of cooling from a molten state to a solid state. If a metal cools rapidly, many grains will form, and the size of the grain will be smaller. The smaller the grain, the shorter the slip planes, and the harder and stronger the metal will be. The opposite will occur if the metal is cooled slowly. Grain size, therefore, directly affects the physical and the mechanical properties of metal and can be changed by various heat treatment methods.

Some grains may be seen with the naked eye. Others can only be seen under magnification. The study of the microscopic structure of metals is called **metallography**. Instruments used to magnify grains are called **METALLURGICAL MICROSCOPES**. These microscopes can magnify grains several hundred times their actual size. Additional magnification can be gained through the use of an **ELECTRON MICROSCOPE**, which can magnify up to many thousand times actual size.

Metallurgical microscopes equipped with devices for photographing the microstructure of metals are known as **METALLOGRAPHIC MICROSCOPES**.

## **SPACE LATTICES**

The arrangement of atoms (the most basic unit of matter) in a crystal can be shown by a graphic illustration called a **SPACE LATTICE**. Each of the four line-dot drawings in figure 15-1 is a space lattice. The dots represent atoms, while the lines make the shape easier to visualize.

The space lattices of most metals can be identified as one of the following four types:

1. Body-centered cubic
2. Face-centered cubic
3. Body-centered tetragonal
4. Hexagonal close-packed

### **Body-Centered Cubic Lattice**

The body-centered cubic lattice (fig. 15-1, view A) contains nine atoms, one at each corner of the cube and one at the center of the cube. In this arrangement, each atom is held in position by the force of the remaining eight atoms.

Metals that have the body-centered cubic arrangement are usually stronger, but harder to work cold, than metals that have a face-centered cubic arrangement (discussed next). Some of the body-centered metals are tungsten, molybdenum (MO), vanadium (V),

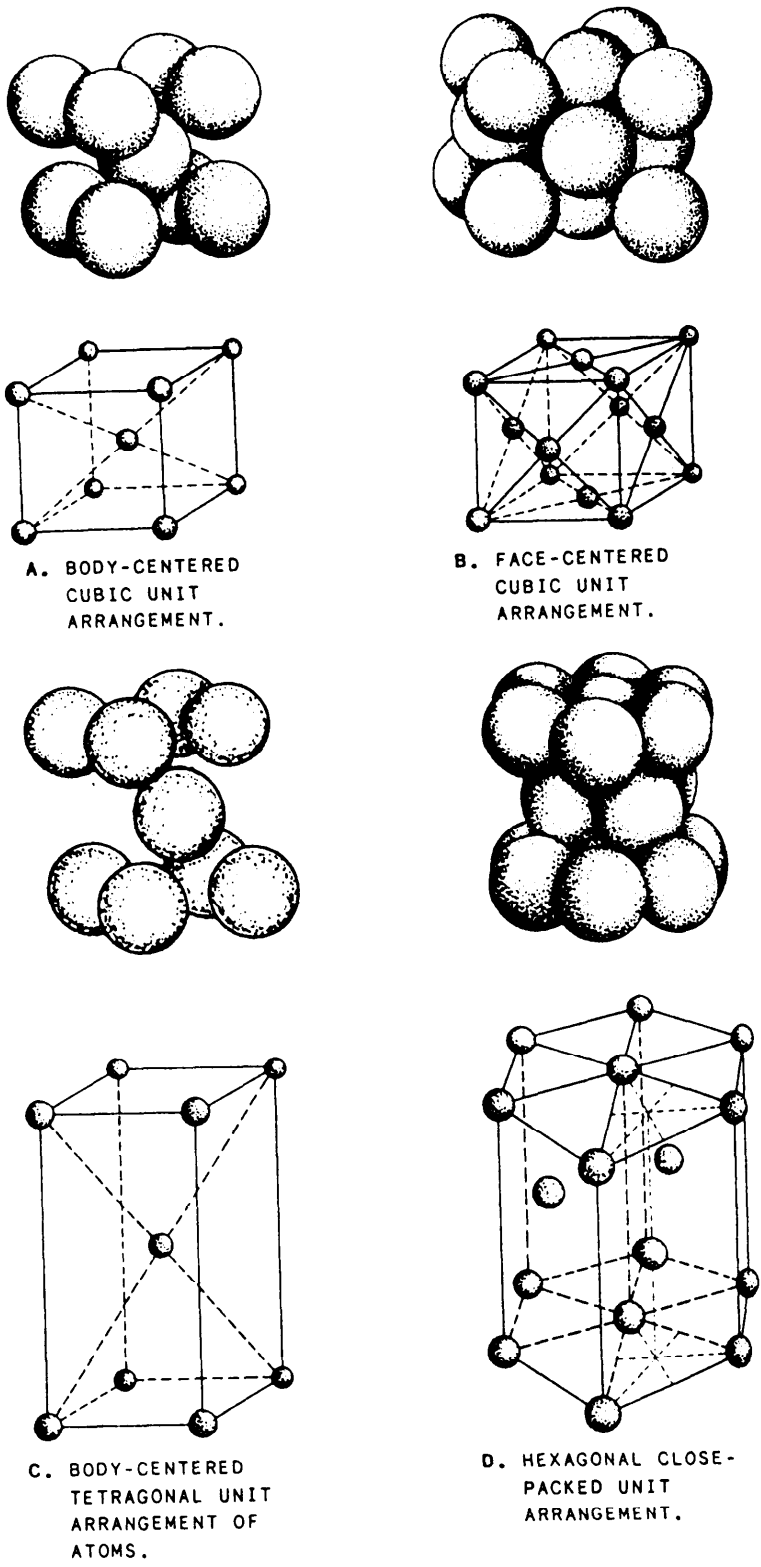


Figure 15-1.—Atom arrangement in a space lattice system.

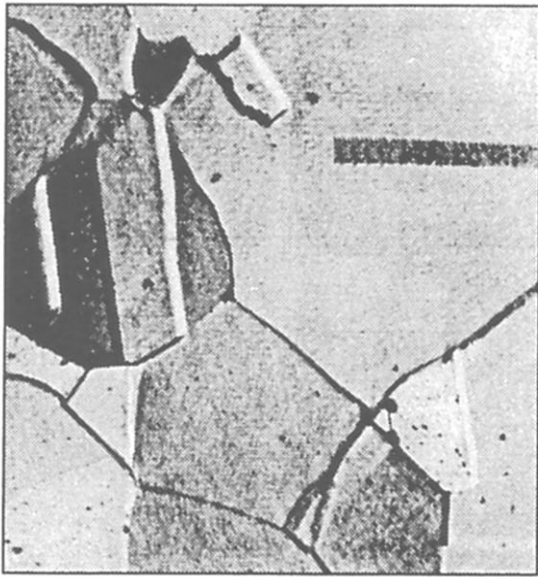


Figure 15-2.—Microscopic structure called austenite magnified 500 times.

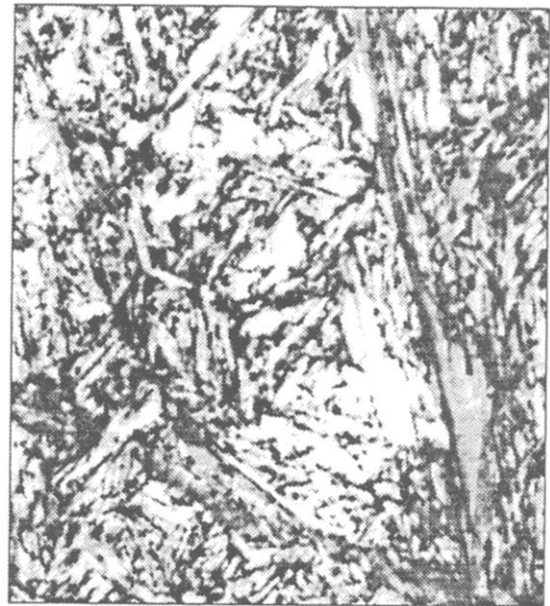


Figure 15-3.—Microscopic structure called martensite magnified 2,500 times.

wolfram(W), columbium, and ferrite (or alpha iron) below its hardening temperature.

### Face-Centered Cubic Lattice

The face-centered cubic lattice (fig. 15-1, view B) contains 14 atoms, one at each corner of the cube and one at the center of each face of the cube. In this arrangement the atoms are more dense (closely packed) than in the body-centered arrangement. Metals that have a face-centered cubic lattice structure include nickel, aluminum, copper, lead, gold, and silver.

When steel is heated to the hardening temperature, the space lattice units in the grain structure transform from the body-centered cubic form to the face-centered cubic form. In this form it is called austenite or gamma iron (fig. 15-2). At the elevated temperature at which austenite forms, the carbon in steel decomposes from its combined state as cementite (iron carbide) to free carbon. The free carbon then dissolves into the solid hot iron to form a solid solution of uniformly dispersed carbon in iron. This form of iron will dissolve up to a maximum of 2 percent carbon. In contrast, the body-centered (alpha) form of iron (ferrite) will dissolve a maximum of about 0.05 percent carbon.

### Body-Centered Tetragonal Lattice

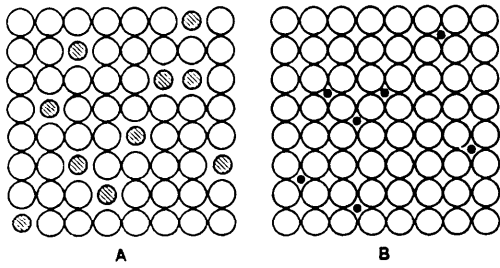
The body-centered tetragonal lattice (fig. 15-1, view C) contains nine atoms and looks like a body-centered cubic lattice stretched in one dimension.

Recall that steel heated to its hardening temperature becomes a face-centered cubic material called austenite. If austenite is quenched at its hardening temperature and cooled rapidly to a temperature of less than 400°F, it will change into MARTENSITE (fig. 15-3) in a body-centered tetragonal arrangement. During the transformation from austenite to martensite, the steel becomes supersaturated with carbon. Because of its extremely high carbon content and the distortion of its structure, martensite is the hardest and most brittle form of steel.

### Hexagonal Close-Packed Lattice

The hexagonal close-packed lattice (fig. 15-1, view D) contains 17 atoms. This structure does not have the high degree of symmetry evident in the cubic structure, and as a result this type of structure is very difficult to deform. Metals that have this structure have little plasticity and are very difficult to work cold. Some examples of this type of metal are cadmium (Cd), cobalt (Co), magnesium (Mg), titanium (Ti), zinc (Zn), and beryllium (Be).

Of the four lattices mentioned, the cubic types are the most important. If you understand the role these structures play in the heat-treating process, you will be able to understand better how desired characteristics are given to various forms of steel. The relationship between atomic structure, carbon content, and



**Figure 15-4.—Space lattices of two forms of solid solution.**  
**A. Atoms of one element replace atoms of another element.**  
**B. Atoms of one element fit between atoms of another element.**

characteristics of the metal will be discussed later in this chapter.

## ALLOTROPY

Some metals may exist in more than one lattice form at a particular temperature. When a metal exists in more than one lattice form it is said to be **ALLOTROPIC** in nature. A change from one lattice structure to another is called an **allotropic change**. The temperature at which allotropic changes take place is called the **TRANSFORMATION TEMPERATURE**. The changes from one form of iron to another are not often instantaneous at a specific temperature. Rather, they generally take place within a range of temperatures called the **TRANSFORMATION TEMPERATURE RANGE**. The temperature of the lower end is called the lower transformation temperature and the temperature of the upper end is called the upper transformation temperature.

## INTERNAL STRUCTURE OF METALS

In alloys (substances composed of two or more metals or of a metal and a nonmetal), the internal structure may be in the form of crystals of pure metals, a solid solution, intermetallic compounds, mechanical mixtures, or some combination of these structures.

In a solid solution, the elements are completely dissolved in each other, with the atoms of one element fitting into and forming parts of the space lattice of the other element. Figure 15-4 illustrates two ways in which solid solutions may exist. The atoms of one element may fit into the spaces between the atoms of another element, as indicated in figure 15-4, view B; or the atoms of one element may replace the atoms of another element in the space lattice, as indicated in figure 15-4, view A.

A solid solution in a metal is similar to many solutions you are familiar with. For example: water dissolves salt. The result is a salty liquid. The taste of the salt and the wetness of the water have not changed. As you see, there has been no change of individual properties. However, you cannot see or distinguish which is water and which is salt. The loss of individual identity is apparent. An example of a familiar solid solution is Monel metal. You know from experience that Monel is tough, and yet soft and plastic; the toughness of nickel and the plasticity of copper have been combined in the form of a metallic solid solution.

The individual elements lose their identity in a solid solution. A polished cross section of a material that consists of only one solid solution shows all grains to be of the same nominal composition.

Ferrite and austenite are two solid solutions that are important constituents of steel. **FERRITE** is the name given to a solid solution of alpha iron and carbon. **AUSTENITE** is the term for a solid solution of gamma iron and carbon. Carbon is only slightly soluble in alpha iron but is quite soluble in gamma iron. Alpha iron at room temperature can hold only about 0.007 percent carbon in solid solution. At a temperature of 2,065°F, gamma iron can hold up to about 2 percent carbon in solid solution.

As an introduction to compounds, consider ordinary table salt. The two poisonous elements, sodium and chlorine, are combined chemically to create a new and different substance, sodium chloride, or table salt. Salt, with its own identity and properties, does not resemble either sodium or chlorine.

Similarly, **INTERMETALLIC COMPOUNDS** are combinations of a metal and some other substance such as carbon or sulfur. Under certain conditions, intermetallic compounds form and a new substance with new properties is created in very much the same manner but on a more complicated basis. Perhaps the most important thing to remember about the intermetallic compounds is the loss of identity and the change in properties of the combining elements. The heat treater quite often uses the change in properties offered by compound formations in metals to create compounds with certain desired properties.

One intermetallic compound of great importance in ferrous alloys is known as **IRON CARBIDE** or **CEMENTITE**. This is an extremely hard and brittle compound that is formed by the combination of iron (a metal) and carbon (a metalloid). The formula for iron carbide, or cementite, is  $Fe_3C$ . This formula shows that three atoms of iron combine with one atom of carbon to produce one molecule of iron carbide, or cementite





Figure 15-5.—Typical structure of low-carbon steel.

The structure of an alloy is described as being a **MECHANICAL MIXTURE** when two or more structural forms are mixed together but are still separately distinguishable. A mechanical mixture of an alloy is comparable—though on a smaller scale—to the mixture of sand and gravel in concrete.

One of the most important mechanical mixtures that occurs in many steels is known as **PEARLITE**. Pearlite, so called because it has a pearly luster when seen under a microscope, is an intimate mechanical mixture of ferrite and cementite in alternate plates or layers. Ferrite is a solid solution, and cementite or iron carbide is an intermetallic compound; in pearlite, the two are closely mixed to form a characteristically layered structure. When the entire structure of the alloy is in the form of pearlite, the composition is referred to as the **EUTECTOID COMPOSITION**. The pearlitic structure is called the **EUTECTOID** or the **EUTECTOID STRUCTURE**.

The internal structure of an alloy may show various combinations of pure metals, solid solutions, intermetallic compounds, and mechanical mixtures. Many of the combinations that are important in steels and other alloys are the result of heating and cooling of the alloy. Figure 15-5 shows, very much enlarged, a typical combination that occurs when plain-carbon steel containing less than 0.83 percent carbon is heated to a certain temperature and then cooled slowly. This combination consists of the solid solution ferrite and the mechanical mixture pearlite, each in crystal form, distributed throughout the alloy. The relative proportions of ferrite and pearlite in this combination depend largely upon the carbon content of the alloy.

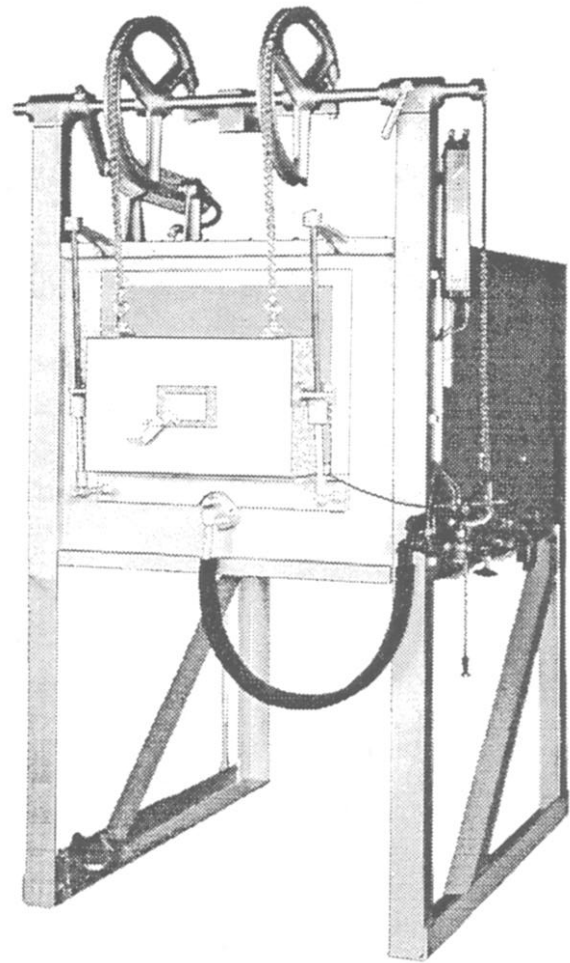


Figure 15-6.—Controlled atmosphere electric furnace used for heat-treating.

## HEAT-TREATING EQUIPMENT

The equipment required for heat-treating consists of furnaces or other heating devices, quenching baths or other cooling devices, temperature controls and indicators, and other controls and indicators required for the proper operation of the equipment or for the control of the process. In addition, heat-treating equipment includes tongs and other devices for handling and holding the work while it is being heated or cooled.

Because heat-treating equipment varies so widely, it is not practical to describe or to give operating instructions for different types in this course. The equipment described here is typical of heat-treating equipment you may be required to use, but it does not include all possible types of equipment. If you are required to heat-treat metals, find out all you can about the equipment that is available before you begin to use it. The instructions furnished by the manufacturer are usually your best—and sometimes only—source of authoritative information on a specific item of heat-treating equipment.

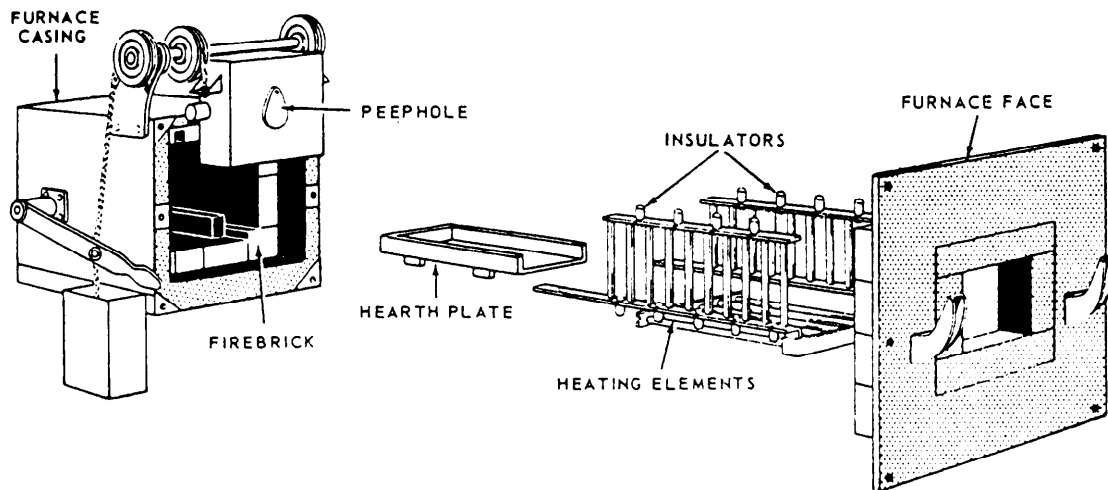


Figure 15-7.—Exploded view of electric furnace used for heat-treating.

## HEATING EQUIPMENT

Equipment designed for the heating of metals includes electric furnaces, fuel-fired furnaces, bath furnaces, and devices for the measurement and control of temperature. Improvised heating devices may include oxyacetylene torches, Hauck burners, forges, and temporary ovens constructed of firebrick and sheet asbestos. We will discuss electric furnaces since they are what most Machinery Repairmen will be using.

The gases that circulate through the furnace heating chamber and surround the metal as it is being heated make up the **FURNACE ATMOSPHERE**. By controlling the composition of the furnace atmosphere, you can produce the type of atmosphere best suited for the heating of a particular type of metal. Furnace atmospheres are generally classified as being oxidizing, reducing, or neutral.

An **OXIDIZING ATMOSPHERE** exists when excess air is circulated through the furnace. Some electric furnaces are designed to operate with an oxidizing atmosphere at all times. An oxidizing atmosphere is indicated by bright, clean walls and a clear, transparent atmosphere in the furnace. Metals heated in an oxidizing atmosphere occasionally develop films of metal oxides (scale) on their surfaces. In some cases, this is undesirable; but in other cases, it is desirable because it tends to prevent further decarburization of the metal. Decarburization is a term used to describe the loss of carbon from the surface of ferrous metals with consequent softening of the material.

A **REDUCING ATMOSPHERE** tends to remove oxygen from the surface of the metal. A reducing atmosphere is often desirable in heat treatment since it tends to prevent oxide formation and other surface deterioration. If decarburization of steel is to be

avoided, however, a neutral atmosphere rather than a reducing or oxidizing atmosphere is used.

A **NEUTRAL ATMOSPHERE** is neither oxidizing nor reducing because it contains no oxygen (oxidizing agent) and no carbon monoxide (reducing agent). In reality, other factors often tend to produce either oxidation or decarburization; therefore, an atmosphere that is described as neutral may not always be totally neutral.

The furnace atmosphere may be the result of the deliberate introduction of a gas or a mixture of gases into the heating chamber. When gases are deliberately introduced into the heating chamber for the purpose of controlling the atmosphere, the furnace is said to have a **CONTROLLED** or **PROTECTIVE ATMOSPHERE**.

## Electric Furnaces

Electric furnaces with a controlled atmosphere are frequently used for heat-treating on repair ships and tenders. Quite often two such units are used on the same ship. One is a relatively low-temperature furnace used for preheating or tempering, and the other is a higher temperature furnace used for hardening. Both types are equipped with control devices for regulating temperature. The high-temperature furnace may also be equipped with rheostats used to increase the rate of heating. A typical electric furnace for shipboard use is shown in figure 15-6. An exploded view of a slightly different type of electric furnace is shown in figure 15-7.

The outer casing of the furnace is usually made of sheet steel. Just inside the casing is a layer of insulating material, such as mica, spun glass, or asbestos. Inside this insulating material is a lining of refractory material, such as firebrick and insulating brick. The refractory lining insulates the furnace, helps maintain the required

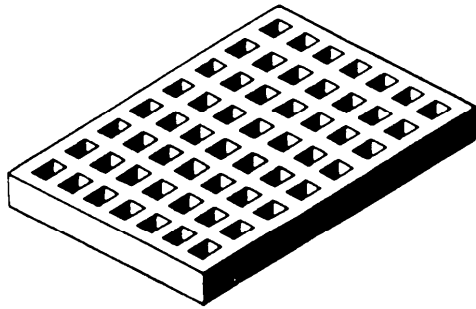


Figure 15-8.—Grid for heat-treating furnace.

high temperatures, and supports the heating elements and the hearth plate.

Hearth plates are placed on the bottom of the heating chamber to support the pieces being heated. Hearth plates must withstand high temperatures without sagging or scaling. They are often made of a special nickel-chromium, heat-resistant alloy. If the furnace is designed for the heat treatment of high-speed steels, the hearth plate may be made of a carbon and silicon.

Grids, usually made of iron-chromium-nickel alloy, keep heavy or long sections of material off the hearth plate. The use of grids ensures more uniform heating of the material and tends to prevent warping. A grid for an electric furnace is shown in figure 15-8.

A special type of electric furnace known as an AIR-CIRCULATING FURNACE is sometimes used for stress-relieving and tempering. Air-circulating furnaces are relatively low-temperature units, usually designed to operate at temperatures ranging from 275° to 1,250°F. Temperature control is both accurate and rapid. The maximum temperature variation is seldom more than plus or minus 5°F, and very rapid changes to a higher or lower temperature are possible.

### Temperature Measurement and Control

The measurement and control of temperature are extremely important in all heat-treating processes. Modern heat-treating furnaces are equipped with various devices for indicating (and in some cases recording) temperatures. Most furnaces are also equipped with temperature controllers.

The most commonly used device for measuring the temperature in a heat-treating furnace is the THERMOELECTRIC PYROMETER. This instrument (fig. 15-9) consists of a thermocouple, an extension lead, and an indicating unit. The indicating unit is calibrated in degrees Fahrenheit or Centigrade.

Some pyrometers merely indicate the temperature; others indicate it and record it. Most electric furnaces are equipped with pyrometers that are controllers as

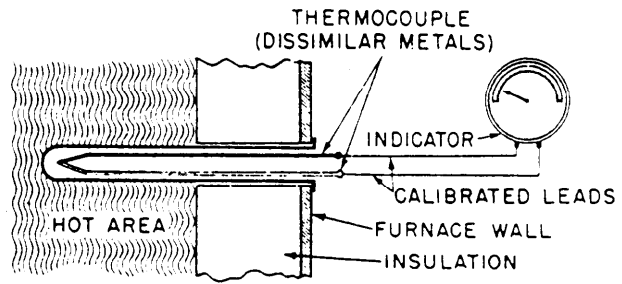


Figure 15-9.—Thermoelectric pyrometer used in heat-treating furnace.

well as measuring devices. This type of instrument can be set to develop and maintain any desired temperature within the limits of the furnace design.

If you are using improvised heat-treating equipment, you will probably not have any accurate way of measuring temperature and will have to improvise methods for determining temperature.

It is possible to estimate the temperature of ferrous metals by noting the color changes that occur when the material is heated. This method is not practical for nonferrous metals since most nonferrous metals melt before they show a color change. At best, the color method of judging temperatures is guesswork. Nonetheless, you should develop some skill in using this technique. It may be the only method you have to estimate temperature when you do not have adequate heat-treating equipment.

The best way to learn to judge the temperature of ferrous metal by color is by heating small samples of clean, polished steel under controlled conditions. This way you can check the color of the sample against the actual temperature. Also, study the color charts that relate color and temperature. Your perception of the colors will be affected by the color and intensity of the light in the furnace or in the room where you are working. Use standard lighting conditions, if possible, when you must estimate the temperature of a metal by observing the color. Charts are available in various handbooks and textbooks on metals. Table 15-1 is a rough guide to the color-temperature relationships of steel.

At temperatures below those given in table 15-1) another type of color determination can be made. If steel is thoroughly cleaned and polished, the surface will appear to change color as the material is heated. An oxide film forms on the polished surface as the steel is heated, and the oxide color corresponds to a certain temperature. Some oxide colors for steel are given in table 15-2.

**Table 15-1.—Relationship Between Color and Temperature of Steel**

<b>Color</b>	<b>Approximate Temperature (°F)</b>
Faint red, visible in darkness . . . . .	750
Faint red, visible in daylight . . . . .	900
Blood red. . . . .	1050
Dark cherry . . . . .	1075
Medium red . . . . .	1250
Cherry or full red . . . . .	1375
Bright red . . . . .	1550
Salmon . . . . .	1650
Grange . . . . .	1725
Lemon . . . . .	1825
Light yellow . . . . .	1975
White. . . . .	2200
Dazzling white . . . . .	2350

**Table 15-2.—Oxide Colors for Steel of Various Temperatures**

<b>Color</b>	<b>Approximate Temperature (°F)</b>
Pale yellow. . . . .	428
Straw . . . . .	446
Golden yellow . . . . .	469
Brown . . . . .	491
Brown dappled with purple . . . . .	509
Purple . . . . .	531
Dark blue . . . . .	550
Bright blue . . . . .	567
Pale blue . . . . .	610

**Table 15-3.—Average Cooling Rates of Some Liquids and Gases Used for Cooling, as Compared with Cooling Rate of Water at 65°F**

Cooling Medium	Cooling Rate, as Compared to Water at 65°F
10-percent brine solution at 65°F . . . . .	1.96
10-percent caustic soda solution . . . . .	1.38
Water at 65°F . . . . .	1.00
Prepared oil . . . . .	0.44
Fuel oil . . . . .	0.36
Cottonseed oil . . . . .	0.36
Neatsfoot oil . . . . .	0.33
Sperm oil . . . . .	0.33
Fish oil . . . . .	0.31
Castor oil . . . . .	0.29
Machine oil . . . . .	0.22
Lard oil . . . . .	0.19
Circulated oil . . . . .	0.032
Still air . . . . .	0.015

Special temperature-indicating crayons or other materials may be available for use in connection with heat treatment. These materials give a much more accurate indication of temperature than can be obtained by merely observing the color of the metal. Temperature-indicating crayons are made of materials that melt rapidly and clearly at specified temperatures. A series of crayons is supplied to cover a wide range of temperatures.

The crayons are easy to use. You select the crayon that is labeled with the temperature you want. As the metal is being heated, stroke the work with the crayon. When the metal is below the temperature rating of the crayon, the crayon will leave a dry or chalky mark on the surface. When the proper temperature is reached or exceeded, the crayon will melt quickly, leaving a liquid smear on the metal. Do not forget that the crayons indicate only the skin or surface temperature of the metal. The interior of the piece may be at quite a

different temperature unless the piece has been soaking for some time.

### COOLING EQUIPMENT

The rate of cooling is controlled by selecting an appropriate cooling medium and cooling procedure. The equipment required for cooling includes the substances used for cooling, a tank or other container to hold the cooling medium, and various kinds of tongs, baskets, and other devices for handling and holding the work.

The rate at which a metal cools depends upon a number of factors. The size, shape, temperature, and composition of the material and the temperature and composition of the cooling medium are the major factors involved. The rate at which a cooling medium can absorb heat is also greatly influenced by circulation. When the cooling medium is agitated, the rate of

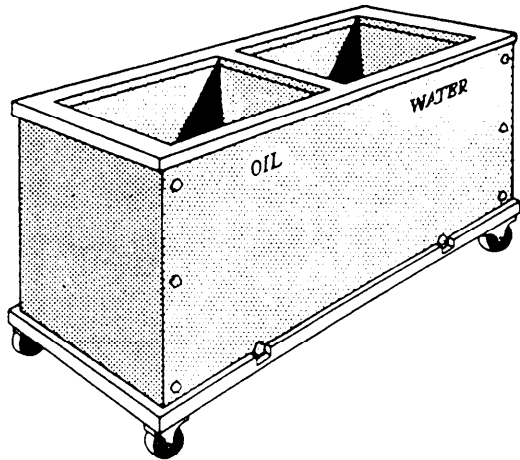


Figure 15-10.—Portable quenching tank for use in heat-treating.

cooling is much faster than when the cooling medium is not in motion. The volume of the cooling medium is also important. As the metal cools, the cooling medium absorbs heat. If the volume is insufficient, the cooling medium will become too hot to cool the work at the required rate. In regular heat-treating shops where the cooling mediums must be used continuously, mechanical cooling systems are used to maintain the cooling medium at the correct temperature.

Liquids, gases, and solids are all used as cooling mediums for heat-treating operations. Table 15-3 shows the relative cooling rates of some commonly used liquids and gases. Solid materials such as lime, sand, ashes, and cast-iron chips are sometimes used when the rate of cooling must be slower than that produced by liquids or gases.

Liquid quenching is accomplished either by **STILL-BATH QUENCHING** or by **FLUSH QUENCHING**. In still-bath quenching the metal is cooled in a tank of still liquid. The only movement of the liquid is that caused by the movement of the hot metal. Flush quenching is used for parts that have recesses or cavities that would not be properly quenched by the still-bath method. In flush quenching, the liquid is sprayed under pressure onto the surface of the piece and into every cavity or recess. This procedure is often used to minimize distortion by providing a relatively uniform quench to all parts of the piece.

Portable quenching tanks of the type shown in figure 15-10 are sometimes used in small shops that do not have permanent, built-in equipment. Portable quenching tanks may have one compartment or several. When more than one quenching medium is to be used, the seal between the compartments must be absolutely

tight to prevent mixing of the mediums. Each compartment is equipped with a drain plug, a screen in the bottom to catch scale and other foreign matter, and a mesh basket to hold the parts being quenched. The mesh basket and the wire screen are suspended in the tank and held in position by clips that fit over the rim of the tank. A portable electric pump may be attached to the rim of the tank to circulate the liquid.

Stationary quenching tanks are usually designed to contain only one liquid. In a stationary quenching tank, the mesh basket that holds the work is usually raised and lowered by air pressure and is controlled by a three-way air valve. The basket can usually be positioned at any level and can be raised above the level of the liquid so the parts can be drained after they have been cooled. Stationary quenching tanks usually have built-in electric pumps to circulate the liquid. **WATER** is often used as a quenching medium for plain-carbon steels and for aluminum and other nonferrous metals. The water must be kept clean by frequent changing. The temperature most often used for water quenching is about 65°F. Normally, the volume of water in the tank should prevent a temperature rise of more than 20°F. When very heavy pieces are being quenched, the temperature rise may exceed 20°F, but it should always be kept as low as possible.

**BRINE** is used for many quenching operations. At any given temperature, brine cannot hold as much dissolved air as fresh water can hold. With brine, therefore, there are fewer air bubbles or gas pockets on the surface of the work. Brine wets the surface more thoroughly and cools the work more rapidly and more uniformly than plain water.

Brine solutions usually contain from 7 to 10 percent salt by weight or 3/4 of a pound of salt for each gallon of water. The correct temperature for a brine quench ranges from 65° to 100°F. Plain-carbon steels and low-alloy steels are often quenched in brine. High-carbon steels and all alloy steels that are uneven in cross section must be quenched very carefully if brine is the cooling medium. Brine cools the material so rapidly that great internal stresses may develop and crack the work. Brine is not used as a quenching medium for nonferrous metals because of its high corrosive effect on these metals.

**OIL** is used to quench high-speed steels and oil-hardened steels. It is also the preferred quenching medium for almost all other steels except where the necessary hardness cannot be obtained by such a relatively slow quench. Although nonferrous metals are not normally quenched in oil, they may be in special

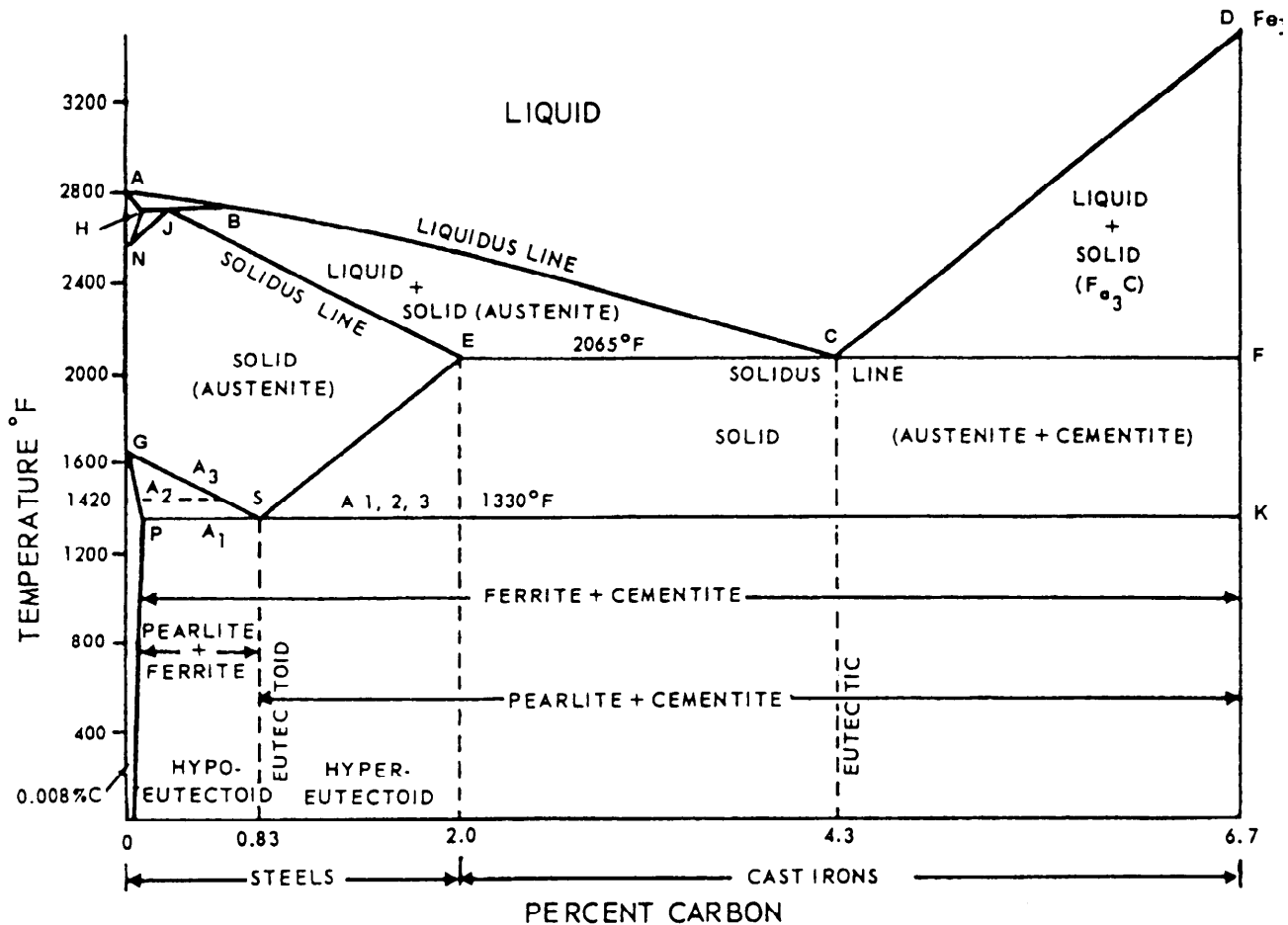


Figure 15-11.—Iron-carbon phase diagram.

cases. A wide variety of quenching oils may be used, including animal oils, fish oils, vegetable oils, and mineral oils. Oils have a slower cooling rate than brine or water but a faster cooling rate than air or solid materials. Quenching oils are usually used in the temperature range of 120° to 150°F.

The chief danger involved in quenching with oil is that a hot metal piece may raise the temperature of the oil to the flash point and cause it to burst into flames. A cover should always be kept near a quenching tank that is used for oil. If the oil flashes into flames, put the cover over the tank immediately to smother the fire.

Some water usually collects in the bottom of the oil tank. The water does no harm if only a small amount is present. If enough water is present that the work extends into the water, the rapid quenching action of the water may cause the piece to crack.

CAUSTIC SODA in water is used for some steels that require rapid quenching. A low-percent caustic soda solution quenches faster than water, but slower than brine. Nonferrous metals are not quenched in caustic soda solutions.

AIR is used for cooling some high-alloy steels and some nonferrous metals. Both still air and circulating air are used. For either method the work pieces are placed on racks or other suitable containers so all parts are uniformly exposed. Air is often circulated by electric fans arranged to provide uniform cooling. Compressed air is sometimes used to concentrate the cooling on particular areas. Compressed air used for this purpose must be entirely free of moisture. Any moisture in the air produces rapid quenching wherever it touches the metal and may cause cracking or hard spots.

MOLTEN LEAD at temperatures ranging from 650° to 1,100°F is often used as a first-stage quench for high-speed steels. A common practice is to quench high-speed steel in molten lead as soon as the work is removed from the furnace and to follow this quench by cooling the part in still air to about 200°F before tempering. Molten lead is not used as a quenching medium for nonferrous metals.

MOLTEN SALT at temperatures ranging from 300° to 1,000°F is sometimes used as a quenching medium

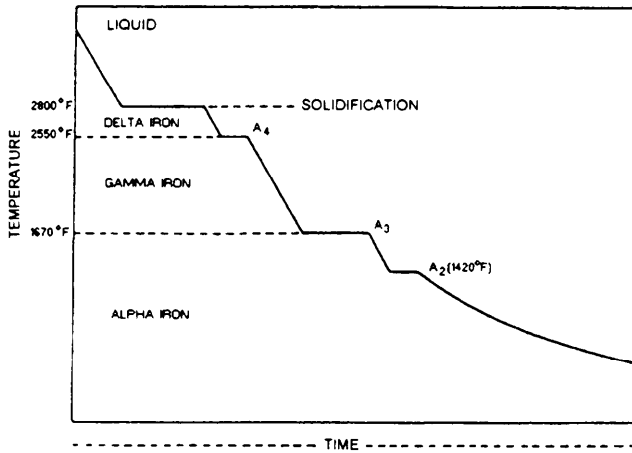


Figure 15-12.—Idealized cooling curve for pure iron.

for steels that tend to crack or distort from more sudden quenches. The final cooling for the temperature of the molten salt bath is accomplished in still air. All traces of the salt must be washed from the steel to prevent corrosion.

**SPECIAL PROTECTIVE ATMOSPHERES** are used for the first-stage cooling of some steels. The protective atmosphere almost entirely eliminates air from around the metal and thus prevents scaling. When the steel has cooled enough so there is no further danger of scaling, the remainder of the cooling is done in still air.

## PRINCIPLES OF HEAT-TREATING FERROUS ALLOYS

As we have seen, the properties of a metal or an alloy are directly related to the metallurgical structure of the material. Since we know that the basic purpose of heat treatment is to **CHANGE** the properties of the materials, let's see how this is done. The following sections deal with basic considerations in heat treatment—equilibrium diagrams, transformation temperatures, and the effects of heating, holding at temperature, and cooling.

### EQUILIBRIUM DIAGRAMS

The relationships among the various metallurgical structures that compose alloys and the temperatures at which these structures exist are shown on existing equilibrium diagrams for all major alloy systems. Figure 15-11 shows a simplified equilibrium diagram (also called a phase diagram) for iron-carbon alloys. This type of diagram gives a good overall view of the effects of temperature on the structures of various

alloys. However, you should note that an equilibrium diagram indicates equilibrium conditions—you might say, ideal conditions of very slow and very uniform heating and cooling. The rate and uniformity of heating and cooling affect the internal structure of alloys and alter the relationship between temperature and internal structure. Therefore, equilibrium diagrams represent theoretical rather than actual conditions.

### TRANSFORMATION TEMPERATURES

If you allow a molten sample of pure iron to cool slowly and measure the temperature of the iron at regular intervals, an idealized (equilibrium) time-temperature plot of the data will appear as shown in figure 15-12. The horizontal discontinuities (temperature arrests) in this curve are caused by physical changes in the iron.

The first arrest at 2,800°F marks the temperature at which the iron freezes. The other arrests (known as transformation temperatures or critical points) mark temperatures at which certain internal changes take place in the solid iron. Some of these temperatures are very important in the heat treatment of steel.

As was mentioned before, the atoms in all solid metals are arranged in a definite geometric pattern. The atoms in iron immediately after freezing are arranged in the body-centered cubic structure. In this crystal structure the unit cell consists of a cube with an iron atom at each of the eight corners and another in the center. Each of the many individual grains (crystals) of which the solid metal is composed is built up of a very large number of these unit cells, all oriented alike in the same grain. This high-temperature iron is known as delta iron.

At 2,550°F (the  $A_4$  point, fig. 15-12), iron undergoes an allotropic transformation; that is, the arrangement of the atoms in the crystal changes. The new crystal structure is face-centered cubic, and the unit cell again consists of a cube with an iron atom at each of the eight corners, but with an iron atom in the center of each of the six faces instead of one in the center of the cube. This form is known as gamma iron. At 1,670°F (the  $A_3$  point), iron undergoes another allotropic transformation and reverts to the body-centered cubic system. This structure, which is basically the same as the structure of delta iron, is stable at all temperatures below the  $A_3$  point and is known as alpha iron. The arrest at 1,420°F (the  $A_2$  point) is not caused by an allotropic change. It marks the temperature at which iron becomes ferromagnetic and is, therefore, termed the magnetic transition. Above this temperature iron is nonmagnetic.



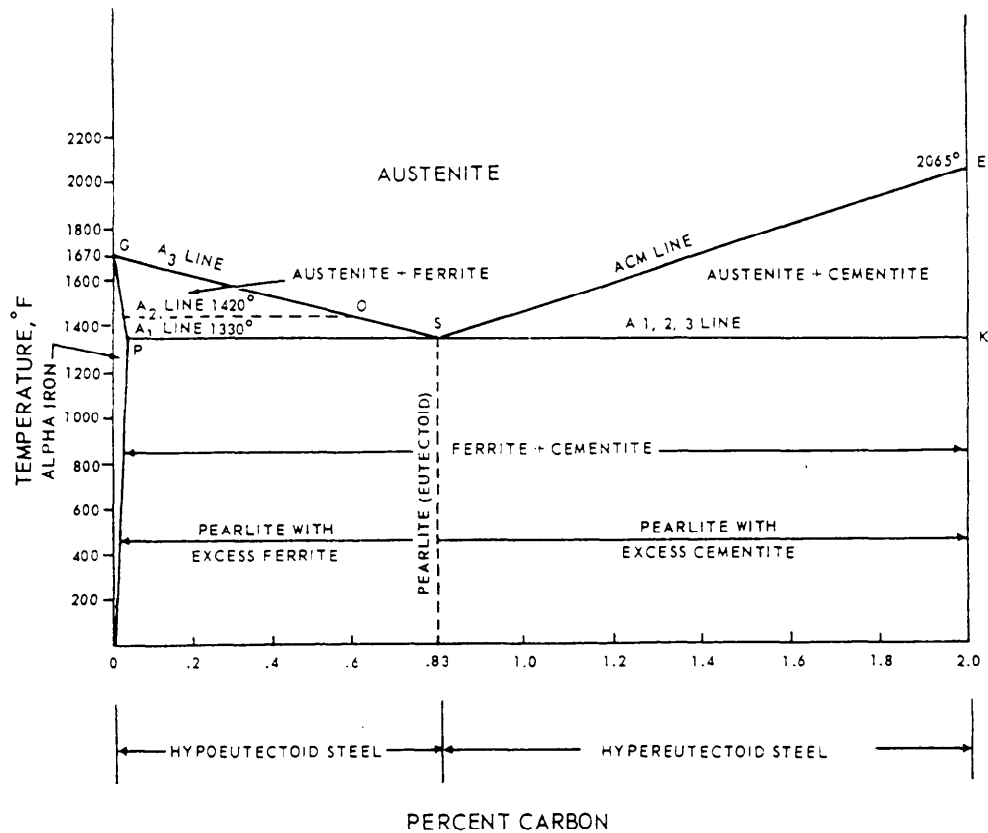


Figure 15-13.—Phase diagram for carbon steels.

These various temperature arrests on cooling are caused by evolutions of heat. On heating, the arrests occur in reverse order and are caused by absorptions of heat. The critical points may be detected also by sudden changes in other physical properties, for instance, expansivity or electrical conductivity.

### IRON-CARBON PHASE DIAGRAM

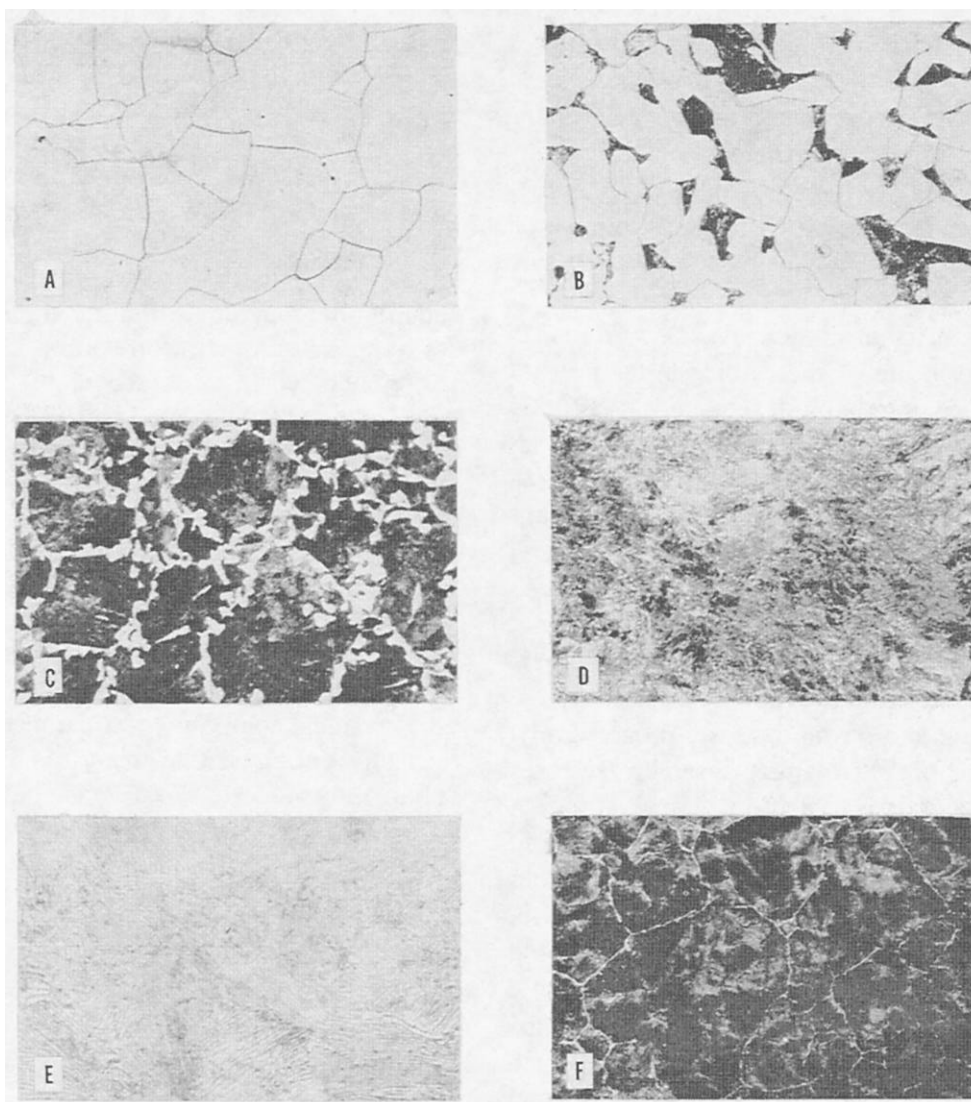
The complete iron-carbon phase diagram represents the relationship between temperatures, compositions, and structures of all phases that may be formed by iron and carbon under an equilibrium condition (very slow cooling). Figure 15-11 illustrates a portion of this diagram for alloys ranging up to 6.7 percent of carbon. The left-hand boundary of the diagram represents pure iron (ferrite), and the right-hand boundary represents the compound iron carbide,  $\text{Fe}_3\text{C}$ , commonly called cementite.

The beginning of freezing (change in state of metal from liquid to solid) of the various iron-carbon alloys is shown by line ABCD (fig. 15-11), termed the LIQUIDUS LINE. The ending of freezing is given by line AHJECF, termed the SOLIDUS LINE. The freezing point of iron is lowered by the addition of carbon (up to 4.3 percent) and the resultant alloys freeze

over a range in temperature instead of at a constant temperature as does the pure metal iron. The alloy containing 4.3 percent carbon, called the eutectic alloy of iron and cementite, freezes at a constant temperature as indicated by point C (fig. 15-11). Eutectic is defined as an alloy or solution having its components in such proportions that the melting point is the lowest possible for this combination of components. Not all alloys are eutectic forming. The formation of a eutectic occurs when a molten alloy or solution of the proper composition freezes. This temperature (in iron) is 2,065°F, considerably below the freezing point of pure iron.

Carbon has an important effect upon the transformation temperatures of iron; it raises the  $A_4$  temperature and lowers the  $A_3$  temperature. This effect on the  $A_3$  temperature is very important in the heat treatment of carbon and alloy structural steels, while the effect on the  $A_4$  temperature is important in the heat treatment of certain high-alloy steels, particularly stainless types.

Solid iron can absorb various amounts of carbon, depending on the crystal structure of the iron and the temperature to which the iron is heated. The body-centered iron (alpha or delta) can absorb very little carbon, whereas the face-centered (gamma) iron can



126.83

Figure 15-14.—Microstructural constituents of slowly cooled carbon steel (all etched with either picral or nital).

absorb a considerable amount as pure austenite, the maximum being about 2 percent at 2,065°F (fig. 15-11, point E). The solid solution of carbon in delta iron is called delta ferrite, and the solid solution of carbon in alpha iron is called alpha ferrite, or, more simply, ferrite.

The physical process by which iron-carbon alloys, especially those containing less than about 0.6 percent of carbon, solidify is rather complicated. All you really need to know, however, is that all iron-carbon alloys containing less than 2 percent of carbon (steel) will, immediately or soon after solidification is complete, consist of single-phase austenite. Cast irons containing greater than 2 percent carbon will consist of two phases immediately after solidification—austenite and cementite. Under some conditions this cementite formed on cooling through the temperature 2,065°F

(ECF in fig. 15-11) will decompose partly or completely into austenite and graphite.

The part of the iron-carbon phase diagram that is concerned with the heat treatment of steel is reproduced on an expanded scale in figure 15-13. Regardless of the carbon content, steel exists as austenite above line GOSE. Steel of 0.83 percent carbon is designated as eutectoid steel, and those with lower or higher carbon as hypoeutectoid and hypereutectoid, respectively.

An eutectoid steel, when cooled at very slow rates from temperatures within the austenitic field, undergoes no change until the temperature reaches 1,330°F (line PSK) (fig. 15-13). At this temperature (known as the  $A_1$  temperature), the austenite transforms completely to a mixture of ferrite and cementite having a typical lamellar structure (fig. 15-14, view E). The mixture is

known as pearlite, and the  $A_1$  temperature is, therefore, frequently referred to as the pearlite point. Since the  $A_1$  transformation involves the transformation of austenite to pearlite (which contains cementite— $Fe_3C$ ), pure iron does not possess an  $A_1$  transformation (fig. 15-13). Theoretically, iron must be alloyed with a minimum of 0.03 percent of carbon before the first minute traces of pearlite can be formed on cooling (fig. 15-13, point P). If the steel is held at a temperature just below  $A_1$  (either during cooling or heating), the carbide in the pearlite tends to coalesce into globules or spheroids; this phenomenon, known as SPHEROIDIZATION, will be discussed later.

A hypoeutectoid steel (less than 0.83 percent carbon), cooled slowly from a temperature above the  $A_3$  temperature, begins to precipitate ferrite when the  $A_3$  line is reached. This ferrite is often called pro-eutectoid, since it forms before the eutectoid temperature is reached. As the temperature drops from the  $A_3$  to the  $A_1$ , the precipitation of ferrite increases progressively, and as the amount of the remaining austenite decreases progressively, its carbon content increases. At the  $A_1$  temperature the remaining austenite reaches eutectoid composition (0.83 percent carbon) and, upon further cooling, transforms completely into pearlite (fig. 15-14, view D). The microstructures of slowly cooled hypoeutectoid steels thus consist of mixtures of ferrite and pearlite (fig. 15-14, views B and C). The lower the carbon content, the higher is the temperature at which ferrite begins to precipitate and the greater is the amount of ferrite in the final structure.

The temperature range between the  $A_1$  and  $A_3$  points is called the transformation range. Theoretically, the critical points in any given steel should occur at about the same temperatures, if the steel is being heated or cooled very slowly. Practically, however, they do not since the  $A_3$  and  $A_1$  points, affected slightly by the rate of heating, are affected tremendously by the rate of cooling. Rapid rates of heating raise these points only slightly, but rapid rates of cooling lower the temperatures of transformation considerably. To differentiate between the critical points on heating and cooling, the small letters *c* (for chauffage, meaning heating) and *r* (for refroidissement, meaning cooling) are added. The terminology of the critical points thus becomes  $Ac_3$ ,  $Ar_3$ ,  $Ac_1$ ,  $Ar_1$ , and so on. The letter *e* is used to designate the occurrence of the points under conditions of extremely slow cooling on the assumption that this represents equilibrium conditions ( $Ae_3$  and  $Ae_{cm}$ ).

## EFFECTS OF HEATING, HOLDING, AND COOLING

We have seen what happens to the structure of an iron-carbon alloy containing 0.83 percent carbon when it is cooled very slowly so all of the transformations occur at the points indicated on the equilibrium diagram. In the same manner, we could use the equilibrium diagram to find the transformation points or ranges for other iron-carbon alloys containing different percentages of carbon.

If we want to change a metal's properties, we have to create a specific grain structure in the metal. We do this primarily by (1) heating the metal at a certain rate to a certain temperature, (2) holding or soaking it at that temperature for a specified time, and (3) cooling it at a specified rate. Thus the three major factors involved in all heat-treating processes are (1) rate of heating, (2) holding time (or soaking time) at the specified temperature, and (3) rate of cooling. A fourth factor—the chemical composition of the material surrounding the alloy during heat treatment—is important in nearly all treating processes.

The rate of heating determines where the changes will occur in the material as it is heated. Increasing the rate of heating raises the temperatures at which the transformations occur. Within certain limits, the faster the material is heated, the higher its transformation temperatures will be. The temperature to which the material is raised and the time it is held at that temperature affect the size of the grains in the final structure. The rate of heating also partially determines whether or not stresses will be set up in the material by the process of heating.

The holding time (or soaking time) at temperature is important for a number of reasons. The holding time must be sufficient to allow all parts of the piece to come to a uniform temperature, except in those cases involving localized hardening of certain areas. If the rate of heating is very slow, uniformity of temperature may be reached with a short holding time. But if the rate of heating is rapid, a longer holding time will probably be required. In any case, holding time must be sufficient to allow the required transformations to take place. As we have seen, the transformations do not occur instantaneously but require a definite time for completion.

The rate of cooling is tremendously important in most heat-treating processes. Increasing the rate of cooling lowers the temperatures at which the transformations occur; and the lower the transformation temperature, the stronger and harder the final product will be. Very rapid cooling does not allow time for the

transformations to be completed in the normal manner, resulting in quite different structures than those obtained by very slow cooling of the same material. Remember this fact about cooling—if you do not cool a metal properly, you will not get the desired results, no matter how carefully you heat and soak the metal. In addition, very rapid cooling can cause internal stresses in your material, which may lead to cracking.

In plain-carbon steel, the properties of the material are largely determined by the form and distribution of the ferrite and the cementite. Most heat treatment of plain-carbon steels consists of heating the material slightly above its transformation temperature, holding it at this temperature until it is completely austenitic, and then cooling it at the rate required to produce a particular kind of structure. Thus austenite, a solid solution of carbon and gamma iron, might be considered the basis from which all plain-carbon steel structures are derived.

As noted before, the very slow cooling of austenite to room temperature produces structures that are combinations of ferrite and cementite. The particular combination depends upon the percentage of carbon in the alloy. With less than about 0.83 percent carbon, the structure is a combination of ferrite and pearlite. With just about 0.83 percent carbon, the structure is entirely pearlitic. With more than 0.83 percent carbon, the structure is a combination of pearlite surrounded by cementite at the grain boundaries as shown in figure 15-14, view F.

If the steel is cooled rapidly, a different structure will result. The austenite will be retained until the material reaches a temperature of about 430°F. At this point the transformation from austenite to a structure called MARTENSITE begins. Martensite is a very hard and highly stressed structure. It is formed at the moment gamma iron changes to alpha iron. Since gamma iron can hold a great deal more carbon in solid solution than alpha iron can, the change from gamma iron to alpha iron causes a sudden dispersion of carbon. Because the transformation from austenite is so rapid, carbon is trapped throughout the structure in this solid solution.

The rate of cooling is controlled by selecting an appropriate quenching medium and cooling procedure. Fresh water, brine, oil, and caustic soda in water are commonly used for rapid quenching. Slower cooling is obtained by air cooling, by packing, and by furnace cooling. Packing consists of burying the heated metal in sand, ashes, or some other substance that is a poor conductor of heat. Furnace cooling consists of shutting off the heat and leaving the piece in the furnace so the metal and the furnace cool together. Ferrous metals are sometimes cooled in baths of molten lead or molten

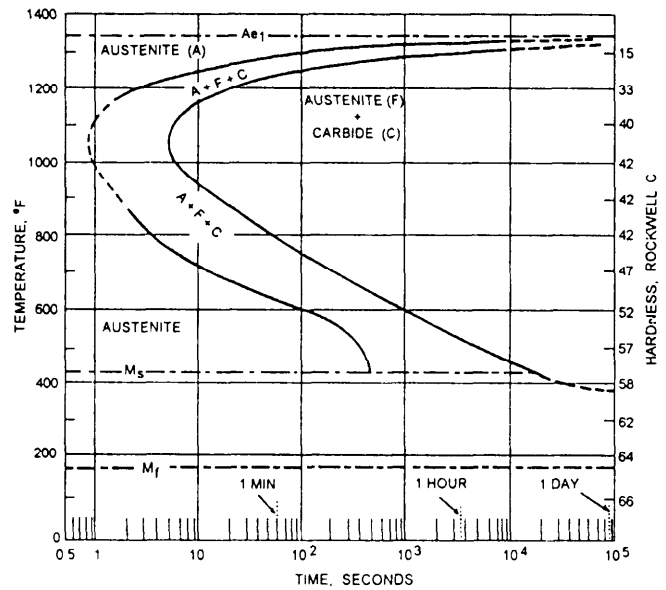


Figure 15-15.—Isothermal transformation diagram (S-curve) for eutectoid carbon steel.

salts. Occasionally, solid materials are used as quenching mediums. In each instance, the quenching medium and the quenching procedure must be selected on the basis of the nature of the material being treated, the size and design of the piece, and the properties that are required in the final product.

### Isothermal Transformation

The course of transformation of austenite when the steel is quenched to and held at various constant elevated temperature levels (isothermal transformation) is shown by a diagram known as the isothermal transformation diagram (I-T diagram). This diagram is also called the Bain S-curve or the TTT diagram, for time, temperature, and transformation. Such a diagram for eutectoid carbon steel is shown in figure 15-15. The I-T diagram of a steel is a map that charts the transformation of austenite as a function of temperature and time and shows approximately how a particular steel will respond to any rate of slow or rapid cooling from the austenite state. The products of this transformation will be discussed below.

**PEARLITE:** Austenite containing 0.83 percent of carbon, cooled quickly to and held at 1,300°F, does not begin to decompose (transform) until after about 15 minutes and does not completely decompose until after about 2 hours (fig. 15-15). Thus, at temperatures just below the critical temperature ( $A_{c1}$ ), austenite is stable for a considerable length of time. The product of the decomposition of austenite at this temperature is coarse pearlite of relatively low hardness. If the austenite is

quickly cooled to and held at a somewhat lower temperature, say 1,200°F, decomposition begins in about 3 seconds and is completed after about 30 seconds, the resultant pearlite being finer and harder than that formed at 1,300°F. At a temperature of about 1,050°F, the austenite decomposes extremely rapidly, with less than 1 second elapsing before the transformation starts and 5 seconds before it is completed. The resultant pearlite is extremely fine and its hardness is relatively high. This region of the S-curve where decomposition of austenite to fine pearlite proceeds so rapidly is called the “nose” of the curve.

**BAINITE:** If the austenite is cooled unchanged to temperatures below the nose of the S-curve (1,050°F), the time required for its decomposition begins to increase. The final product of decomposition now is not pearlite, but a new structure called bainite, possessing unusual toughness with hardness even greater than that of very fine pearlite. Depending on the temperature, a certain interval of time is necessary before austenite starts to transform into either pearlite or bainite. Additional time is necessary before the transformations are completed.

**MARTENSITE:** If the austenite is cooled unchanged to relatively low temperatures (below about 430°F for the eutectoid carbon steel), partial transformation takes place instantaneously; the product of transformation is martensite. Austenite transforms into martensite over a temperature range with the amount that transforms being a function of the temperature. Only minute amounts will transform at about 430°F; practically all of the austenite will be transformed at about 175°F. The beginning of this transformation range is termed the  $M_s$  (martensite start) temperature and the end of the range is termed the  $M_f$  (martensite finish) temperature, as shown in figure 15-15. As long as the temperature is held constant within the  $M_s - M_f$  range, the portion of the austenite that does not transform instantaneously to martensite remains untransformed for a considerable length of time, eventually transforming to bainite.

In ordinary heat treatment of the plain-carbon steels, austenite does not transform into bainite. Transformation of the austenite takes place either above or at the nose of the S-curve, forming pearlite, or in passing through the  $M_s - M_f$  range, forming martensite or both. For austenite to be transformed entirely into martensite, it must be cooled rapidly enough so the temperature of the center of the steel, which cools more slowly, is lowered past the nose of the S-curve in less time than is necessary for transformation to start at this temperature. If this is not done, part of the steel

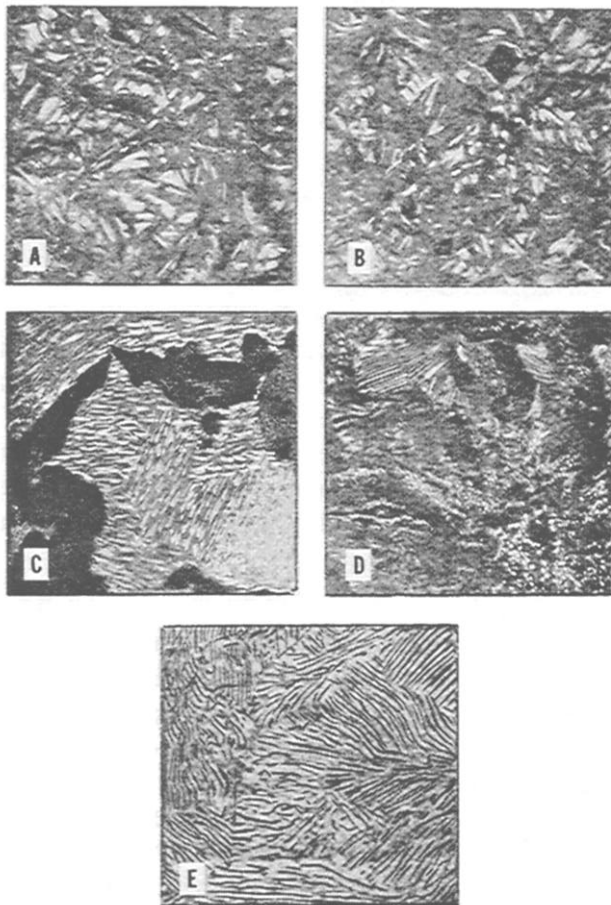
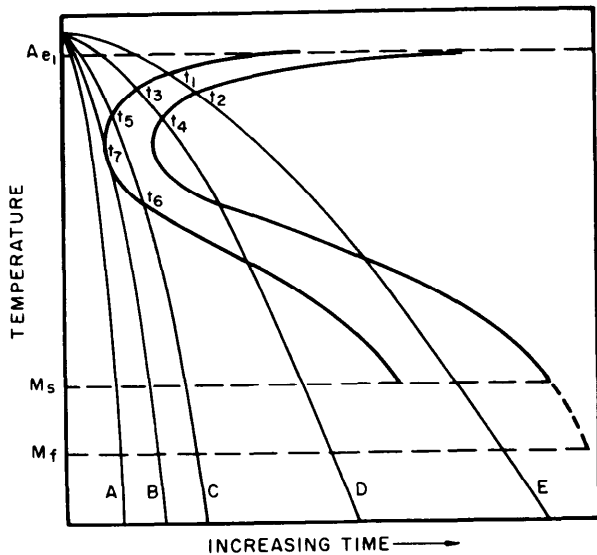
transforms into pearlite at the high temperature and the remainder transforms into martensite at the low temperature ( $M_s - M_f$  temperature range). The resulting material will then transform to a nonuniform structure that is usually not desirable.

### Continuous Cooling

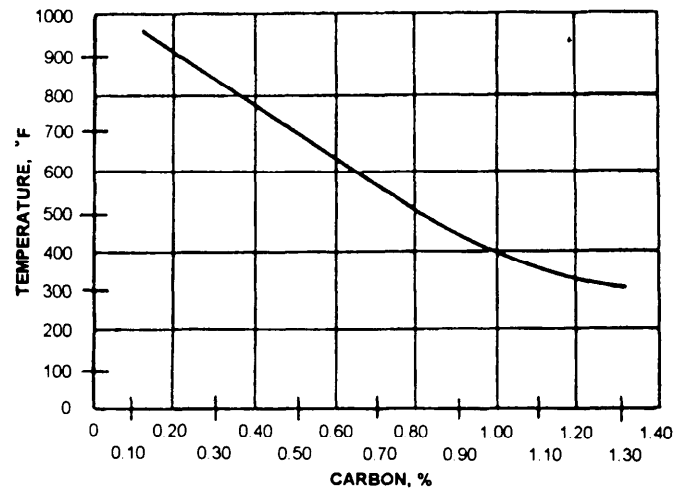
Figure 15-16 represents a theoretical S-curve on which are superimposed five theoretical cooling curves. Curves A to E represent successively slower rates of cooling that would be obtained, for instance, by cooling in (A) iced brine, (B) water, (C) oil, (D) air, and (E) the furnace.

Steel cooled according to curve E begins to transform at temperature  $t_1$  and completes transformation at  $t_2$ ; the final product is coarse pearlite with relatively low hardness. When the steel is cooled according to curve D, transformation begins at  $t_3$  and is complete at  $t_4$ ; the final product is fine pearlite and its hardness is greater than that of the steel cooled according to curve E. When the steel is cooled according to curve C, transformation begins at  $t_5$  and is only partially complete when temperature  $t_6$  is reached. The product of this partial transformation is very fine pearlite. The remainder of the austenite does not decompose until the  $M_s$  temperature is reached. Then it begins to transform to martensite, and completes this transformation at the  $M_f$  temperature. The final structure is then a mixture of fine pearlite and martensite (typical of an improperly quenched steel) with a higher hardness than was obtained with the steel cooled according to curve D. The rate of cooling represented by curve B is just sufficient to intersect the nose of the S-curve. Consequently, only a minute amount of austenite decomposes into fine pearlite at temperature  $t_7$ ; the remainder of the austenite is unchanged until the martensite transformation range is reached. If the steel is cooled at a slightly faster rate, so no transformation takes place at the nose of the S-curve, the steel is completely hardened. This particular rate is termed the critical cooling rate and is defined as the slowest rate at which the steel can be cooled and yet be completely hardened. Since this rate cannot be directly determined, the rate indicated by curve B, producing only a trace of fine pearlite, is frequently used as the critical cooling rate. The hardness of the resultant martensite is equivalent to the maximum that can be obtained. Samples cooled at a faster rate, such as that indicated by curve A, are also completely martensitic but are no harder than the sample cooled according to the critical cooling rate.

The rate at which a steel cools through the temperature in the vicinity of the nose of the S-curve is



**126.85**  
**Figure 15-16.**—Schematic diagram illustrating the relation between the S-curve, continuous cooling curves, and resulting microstructures of eutectoid carbon steels.



**Figure 15-17.**—Influence of carbon on the start of martensite ( $M_s$ ) transformation of high-purity, iron-carbon alloys.

of critical importance. Somewhat slower rates of cooling above and below this temperature range can be tolerated and a completely hardened steel (one that is completely martensite) can be obtained if the cooling through the temperature interval at the nose of the S-curve is sufficiently fast. In practice, however, steels are usually cooled rapidly from the quenching temperature to relatively low temperatures (20° to 250°F) and then tempered immediately to prevent cracking.

Although the discussions of the decomposition of austenite have been limited to a steel of eutectoid composition, other steels behave in a similar manner, at different temperatures and times of reaction. In hypoeutectoid steels, free ferrite plus pearlite are formed if transformation begins above the temperature range at the nose of the S-curve. The amount of free ferrite decreases as the temperature of transforming approaches the nose of the curve. In hypereutectoid steels, free ferrite plus pearlite are formed if transformation occurs above the nose. The time for the start of the transformation at the nose increases as the carbon increases up to the eutectoid composition, and then decreases with further increase in carbon. That is, the nose is shifted to the right on the time axis (fig. 15-15) as the carbon is increased to 0.8 percent and back to the left with further increases in carbon content.

The temperature of formation of bainite is not appreciably affected by carbon content, but the time for its formation increases with the carbon.

Both the  $M_s$  and the  $M_f$  temperatures are lowered significantly by increasing carbon content, as shown for  $M_s$  in figure 15-17. The  $M_f$  temperatures of the plain-carbon steels have not been adequately determined.

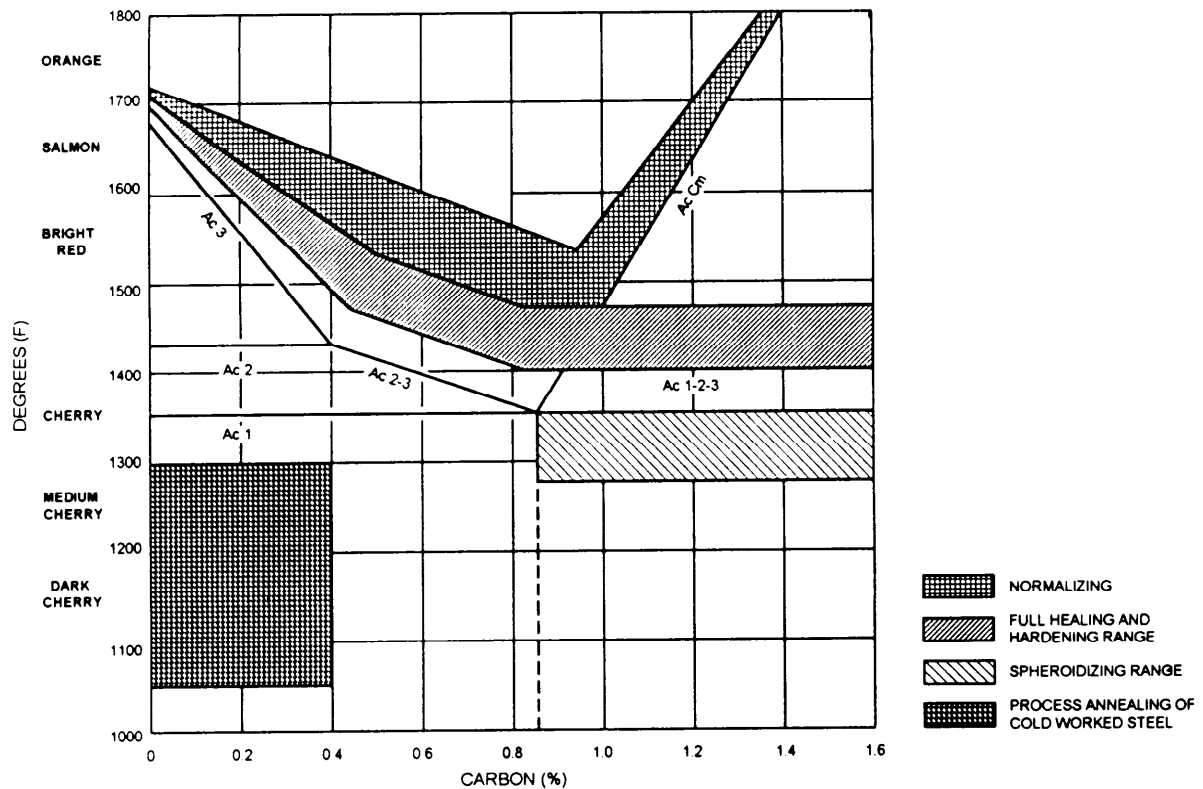


Figure 15-18.—Heat treatment temperature ranges.

Available information indicates that the  $M_f$  of high-carbon steels is actually below room temperature. Slight amounts of austenite are frequently retained in quenched steels, especially in the higher carbon grades, even when they are cooled to room temperature.

### HEAT-TREATING FERROUS METALS

The heat-treating processes most commonly used for ferrous metals are hardening, tempering, annealing, normalizing, spheroidizing, and case hardening. Annealing is the only one of these processes that is also used for nonferrous metals. Some nonferrous metals (including some aluminum alloys and some magnesium alloys) can be hardened by a process generally referred to as precipitation heat treatment. Precipitation hardening is discussed in the section of this chapter on nonferrous metals. Figure 15-18 shows the heat treatment temperature ranges. You should refer to this figure as you study the following information on hardening, normalizing, and spheroidizing temperatures.

### HARDENING

Many tools and pieces of equipment must be hardened before they are used. Cutting tools, chisels,

twist drills, and other tools must be hardened so they can retain their cutting edges. Surfaces of roller bearings, parallel blocks, and armor plate must be hardened to prevent wear and penetration. Hardening is used to increase tensile strength as well as to increase hardness. Since hardening increases the brittleness of the material, most alloys are tempered after being hardened.

Steels are hardened by being heated to a temperature just above the upper transformation temperature, soaked long enough to ensure a completely austenitic structure, and then cooled rapidly. This result is either fine-grained pearlite, bainite, or martensite. If maximum hardness is to be developed, the austenite must be transformed to martensite. Martensite is extremely hard and strong, has great resistance, and has practically no machinability.

Carbon steels are usually quenched in brine or water to ensure rapid cooling. The production of martensite throughout a plain-carbon steel is extremely difficult, requiring that the steel be cooled to below 1,000°F in less than 1 second and that the remainder of the cooling be quite rapid. If more than 1 second is taken for the first part of the cooling (to below 1,000°F), some of the austenite will transform into fine pearlite. Pearlite varies

in hardness, but it is much softer than martensite. If the purpose of the hardening is to develop something less than maximum hardness, the first part of the cooling (to below 1,000°F) must still be accomplished within 1 second; then the remainder of the cooling must be done at a somewhat slower rate.

The rate of quenching alloy steels depends upon the composition of the material. In general, a slower quench is used for hardening alloy steels than is used for hardening plain-carbon steels.

Various quenching mediums are used to produce the desired end results. The more common quenching mediums are oil, water, and brine. When water or brine is used, the temperature of the bath must not rise above 80°F. Generally, 70°F is the best temperature for these quenching mediums. Above 80°F, water loses thermal conductivity.

The plain-carbon steels are generally quenched in water or brine; brine is preferred because it has less tendency to cause steam pockets to form. Steam pockets may cause soft spots or uneven stresses. These steels require a very active agitation or shaking action when quenched. The agitation removes the steam bubbles from the surface of the metal. When the quenched material reaches about 200° to 250°F, or a temperature low enough to dry the material thoroughly without too much sizzle, it can be removed from the water and tempered immediately.

The alloy steels, with the exception of the high-alloy, air-hardening steels, are generally oil quenched. The oil bath should be maintained at a temperature of 120° to 150°F. (This is just below the  $M_f$  line of most low-alloy steels.) At this temperature the heat-treating oils have a lower viscosity, and therefore, a better and more uniform cooling effect. The warm oil also results in a more moderate cooling rate, which lessens the chance of residual stresses and cracking.

Although steels must be heated and soaked so the structure becomes completely austenitic, you should take care to see that they are not overheated and that they are not held too long at temperature. Using too high a temperature or too long a soaking period allows a coarse grain structure to develop.

## TEMPERING

After hardening, most alloys are tempered to reduce brittleness and to relieve some of the high internal stresses developed during hardening. Tempering

always follows, rather than precedes, the hardening process. Tempering is occasionally done after materials have been normalized, but its major use is after hardening.

In some alloy steels tempering may increase hardness when tempered to certain temperature ranges. In most other materials, however, tempering causes an unavoidable loss of some hardness. The amount of hardness removed by tempering depends upon the tempering temperature; the higher the temperature, the softer the material will be.

Tempering is always done at temperatures below the lower transformation point. In this respect, tempering differs from hardening, annealing, and normalizing, which all involve heating the material to temperatures above the upper transformation point.

The temperatures used for tempering are selected on the basis of the properties required in the final product. For example, permanent magnets are tempered at 121°F because they must retain considerable strength and hardness. Case-hardened objects are also tempered at relatively low temperatures (212° to 400°F) because the surface of such objects must remain hard. Many cutting tools are tempered at 430°F or below so they will retain hardness. Battering tools must have great impact resistance and must be able to cut or penetrate metal; therefore, battering tools are tempered between 450° and 600°F even though the higher temperatures mean some sacrifice of hardness to produce impact resistance. Springs are tempered between 600° and 900°F because the property of elasticity is more important in a spring than the property of hardness. Tools made of high-speed steels are tempered at 1,050° to 1,100°F. Note, however, that with high-speed tools the high tempering temperature increases, rather than decreases, hardness. This increase in hardness occurs because high-speed steels retain austenite during quenching; when the hardened steel is tempered, the austenite changes to martensite.

Since tempering uses temperatures below the lower transformation point, the rate of cooling generally has no effect upon the structure of the material. However, some nickel-chromium steels and a few other special steels become brittle if they are heated to the tempering temperature and then allowed to cool slowly. These steels, which are often called temper brittle or blue brittle steels, must be quenched rapidly from the tempering temperature to prevent brittleness. In general, however, steels are cooled



slowly from the tempering temperature by cooling in still air.

Tempering is usually done before the material has completely cooled from the hardening process. The holding time at temperature varies according to the thickness of the material, but the minimum time is about 1 hour. If the part is more than an inch thick, the holding time should be increased by about 1 hour for each additional inch of thickness.

## ANNEALING

ANNEALING is a term used to describe any heat-treatment process that is used for the primary purpose of softening the metal. Two types of annealing processes are commonly used. FULL ANNEALING is done to soften the metal and make it more ductile, and to relieve internal stresses caused by previous treatment such as casting, cold working, or hot working. The operation known as PROCESS ANNEALING or STRESS RELIEF ANNEALING is done to soften the metal somewhat, although not as much as by full annealing, and to relieve internal stresses.

In general, full annealing requires higher temperatures, longer soaking time, and slower cooling than process annealing. In the full annealing of steels, the steel is heated to a temperature that is 25° to 50°F above the upper transformation point. In the process annealing of steels, lower temperatures are generally used. The rate of cooling used for annealing varies greatly, depending upon the metal being annealed and the degree of softening required.

## NORMALIZING

The form of heat treatment known as NORMALIZING is used only for ferrous metals. Normalizing is sometimes used as a preliminary step before full annealing. The chief purposes of normalizing are (1) to relieve internal stresses caused by forging, bending, machining, or other working, or by uneven cooling; and (2) to give a uniform predictable grain structure. Steel that has been normalized is soft and ductile enough for many purposes, but it is harder than steel that has been fully annealed. Normalizing is sometimes followed by tempering, particularly in the case of certain steels that tend to become brittle when normalized.

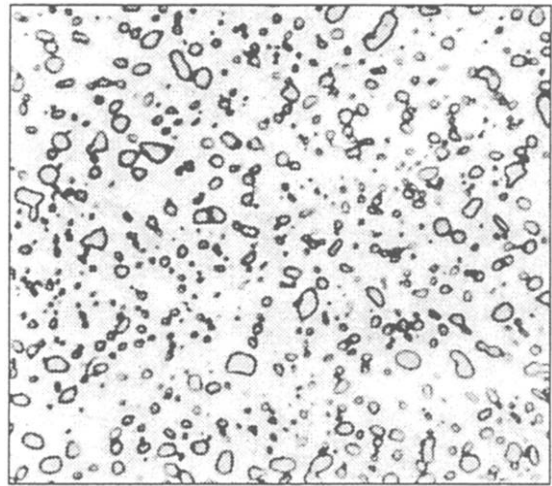


Figure 15-19.—Microscopic structure called spherodite magnified 1,000 times.

In normalizing, the steel is heated to a temperature above the upper transformation point and is cooled in still air.

## SPHEROIDIZING

SPHEROIDIZING is a term used to describe any heating and cooling process that produces a rounded or globular form of iron carbide in the steel. This globular or spheroidal form of iron carbide is developed when fine pearlite is heated to a temperature just below the lower transformation point of the steel, held at this temperature for a long time, and then cooled very slowly. Temperatures, holding time, cooling rates, and other details of the process vary, depending upon the carbon content of the steel and the extent of spheroidizing that is required. In general, the object of spheroidizing is to improve machinability. Spheroidizing is sometimes regarded as being a special annealing process. The typical globular form of spheroidized steel is illustrated in cross section in figure 15-19.

## AUSTEMPERING

AUSTEMPERING is a hardening treatment of metals that involves quenching the metal in a bath of molten salt maintained above the start of the martensite temperature and holding it until transformation is complete. The product formed is called bainite; a tough, hard structure.

There are two distinct advantages of austempering—(1) the high degree of freedom it provides

from distortion and quenching cracks, and (2) normal tempering is not required after the process.

## **MARTEMPERING**

MARTEMPERING is the quenching from the normal austenitizing temperature in a molten salt bath maintained at approximately the start of the martensite temperature. The part is held at this temperature long enough to allow equalization of temperature throughout the piece, but not long enough to allow any transformation to take place. The material being heat-treated is then removed from the hot bath and allowed to air cool through the martensite temperature range, followed by tempering to obtain the desired mechanical properties. This two-step cooling process has the same advantage as austempering—freedom from distortion and quenching cracks.

## **CASE HARDENING**

CASE HARDENING is a process by which a steel can be given a hard, wear-resistant surface while retaining a softer but tougher interior than would be possible if the whole piece were hardened. Steels may be case hardened by carburizing, cyaniding, nitriding, and various other processes.

CARBURIZING is a term applied to several case-hardening processes in which carbon is introduced into the surface layer of the steel. The steel is heated in contact with a substance that has a high carbon content; it is held at a temperature above the upper transformation temperature for a suitable length of time and is then quenched rapidly to produce a hardened outer layer or “case” over a softer, tougher core. As a rough indication, a carburized depth of about 0.030 to 0.050 inch can be obtained in about 4 hours at 1,700°F, depending upon the type of carburizing agent, which may be a solid, liquid, or gas.

Sometimes the steel to be carburized is packed in a substance such as charcoal and is then heated in a furnace. The length of time the piece is left in the furnace determines the depth to which the carbon will be absorbed. For many pieces the procedure is to carburize the material, allow it to cool slowly, reheat it, and then harden it by quenching. Small pieces are sometimes dumped into the quenching medium as soon as they are removed from the carburizing furnace.

Other methods of carburizing use gases or liquids that have a high carbon content. Although these methods also use the principle of increasing the carbon content to harden the outer shell or case of the steel, they use different equipment and different procedures.

CYANIDING can be used to obtain a hard superficial case on low-carbon steels. The process involves the introduction of both carbon and nitrogen into the surface layers of the steel. Steels to be cyanided normally are heated in a molten bath of cyanide-carbonate-chloride salts and then quenched in brine, water, or mineral oil. The temperature of operation is generally within the range of 1,550° to 1,600°F. The depth of the case is a function of time, temperature, and composition of the cyanide bath. The time of immersion is quite short as compared with carburizing, usually varying from 15 minutes to 2 hours. The maximum case depth is rarely more than about 0.020 inch and the average depth is considerably less.

NITRIDING is still another method by which a case or skin of hardened steel can be produced. The piece to be case hardened is put into a furnace and heated to between 950° and 1,200°F and, at the same time, is exposed to ammonia gas. The heat of the furnace causes the ammonia to break down into nitrogen and hydrogen. Some of the nitrogen combines with the elements in the steel to form chemical compounds called nitrides in the outer layer of the steel. These nitrides give the surface its hard, wear-resistant qualities.

## **CARBON TOOL STEELS**

The carbon content of plain-carbon steels ranges from about 0.20 to 1.13 percent. To heat-treat these steels, heat them uniformly to 1,450° to 1,550°F, using the lower end of the temperature range for the higher carbon content. Use brine or water as the quenching medium, and agitate the part vigorously to prevent the accumulation of bubbles on the surface of the metal. Do not remove these steels from the quench until they have reached a temperature of less than 200° to 250°F. To prevent cracking, do not allow the steel to cool below 125°F and follow the cooling immediately with tempering. Tools made from these steels do not have to withstand severe usage or high cutting speeds. Some examples are wrenches, hammers, pliers, knives, simple dies, and low-speed cutting tools.

Table 15-4.—Heat-Treating Temperatures and Quenching Medium for Standard SAE Steels

SAE NO.	NORMALIZING TEMP. (°F)	HARDENING TEMP. (°F)	QUENCH	TEMPERING TEMP. (°F)
1020	1650-1700	1600-1650	water	200
1030	1650-1700	1600-1650	water	200
1040	1600-1650	1500-1550	water	200
1050	1600-1650	1500-1550	water	200*
1060	1550-1600	1450-1550	water or oil	200*#
1070	1550-1600	1450-1550	water or oil	200*#
1080	1550-1600	1450-1500	water or oil	200*#
1090	1550-1600	1450-1500	water or oil	200*#
1345	1600-1700	1450-1500	oil	200*
2345	1600-1700	1450-1500	oil	200#
3140	1600-1650	1455-1550	oil	200"
4130	1600-1650	1550-1600	water	200*
4140	1600-1650	1525-1575	oil	200*
4340	1600-1650	1475-1525	oil	200*
4060	1550-1600	1500-1550	oil	200*
5140	1600-1650	1500-1550	oil	200*
5210	1550-1600	1425-1475	water	200*
6150	1600-1650	1550-1600	oil	200*
8630	1600-1650	1550-1600	water	200*
8640	1600-1650	1525-1575	oil	200*

\*Temper immediately after quenching. Lower temperatures will result in a harder final product.  
 #Use water for maximum hardness. Use oil for toughness and for intricate shapes.  
 Note: Temperature of water quench is 70°F.  
 Temperature of oil quench is 120-150°F.

Table 15-4 will assist you in choosing the proper quenching medium and temperatures for the standard SAE steels.

### ALLOY TOOL STEELS

The number of alloy tool steels is too great to include them all in this text, so we will deal with the type most important to you. You, as a Machinery Repairman, are concerned primarily with the manufacture of taps, dies, reamers, hobs, and form tools. An

all-around tool steel for this purpose is type 01. This steel is listed under QQT-570 and is available in the standard stock system in various shapes and sizes. Type 01 is suitable for all applications except where a high-speed steel is required. It heat treats well and is readily machinable in the spheroidized condition. Type 01 stock replaces the 46S40 class C-5.

Type 01 should be preheated slowly to 1,200°F, then transferred to an oven at 1,450°F and soaked at heat for about 20 minutes per inch of cross section, and then

quenched in warm oil (120° to 140°F). Do not remove the material from the oil bath until you can hold the work comfortably in your hand. This procedure should result in a minimum hardness of 65 Rc. Temper to the desired hardness.

## HEAT-TREATING NONFERROUS METALS

The information in this section deals primarily with the heat-treating of nonferrous alloys. For specific information on a particular composition, consult the *Metals Handbook*, published by the American Society for Metals, or any handbook that deals with heat-treating nonferrous metals.

You can anneal most nonferrous metals by heating them uniformly within a certain temperature range, soaking them within this temperature range, and then cooling them back to room temperature. In most cases, the annealing temperature for most nonferrous metals is the temperature at which recrystallization takes place. For example, aluminum recrystallizes at a temperature of 300°F and copper recrystallizes at 390°F.

The rate at which the metal may be cooled from the annealing temperature depends upon the type of metal. If the metal is pure, or nearly so, or if it remains a solid solution without precipitation when cooled, any method of cooling is usually satisfactory. If, on the other hand, the constituents precipitate during or after cooling, furnace cooling may be necessary for complete annealing to occur.

There are two types of heat treatment of nonferrous alloys—the solution treatment and the precipitation treatment. Some alloys require both treatments. Others require only the solution treatment.

The solution treatment consists of heating the alloy to the temperature at which the principal constituents go into solid solution, soaking the alloy at this temperature to produce a uniform structure, then cooling it at a rate fast enough to retain the solid solution at room temperature. You should remain aware that different alloys have different solution temperatures.

After a nonferrous alloy has been solution treated, it is in a form of supersaturated solid solution. For the alloy to attain maximum hardness and strength, excess hardening constituents that are soluble at room temperature must precipitate from the solid solution. After the precipitation is complete and the alloy has reached its full hardness and strength, it is said to be AGE HARDENED. Alloys that do not precipitate at

room temperature are given the precipitation treatment called artificial aging. Precipitation from aging or artificial aging usually causes an increase in hardness strength and a decrease in ductility.

The following definitions will aid you in understanding some of the terminology used in heat-treating nonferrous alloys:

- Homogenizing—a mill process that uses high temperature for prolonged periods to eliminate or decrease segregation in castings that are to be hot- or cold-worked. This process is usually used for copper alloys.

- Stress equalizing—a low temperature heat treatment used to balance stress in cold-worked material with decreasing mechanical strength properties induced by the cold-working. Nickel and nickel alloys may be subjected to this heat treatment, depending on their chemical composition, the fabrication requirements, and the intended usage of the parts made from the metals.

## HEAT-TREATING PROBLEMS

No matter how carefully you follow instructions for heat-treating, you may occasionally find yourself with a job that just will not turn out right. To some extent you can avoid this problem by knowing in advance something about the many problems encountered in heat-treating metals and alloys. The most common heat-treating problems include (1) design problems, (2) cracking, (3) warping, (4) soft spots, (5) size changes, and (6) spalling, and (7) blistering.

## DESIGN PROBLEMS

Although you are not usually in a position to do much, if anything, about the design of a piece to be heat treated, you should have some knowledge of the effects of design upon heat treatment. Unsatisfactory performance of tools and structural parts is often the result of poor design rather than poor materials, poor fabrication, or incorrect heat treatment. Errors in design cannot be corrected by heat treatment, but you can minimize the problems of heat-treating a poorly designed piece if you know how to compensate for design errors when heat-treating the piece.

When a piece of metal is removed from the heat-treating furnace, its temperature is uniform throughout. Whether or not this piece will cool uniformly depends largely upon the design. Uniform cooling is, of course, a slightly inaccurate term; no piece of metal can cool

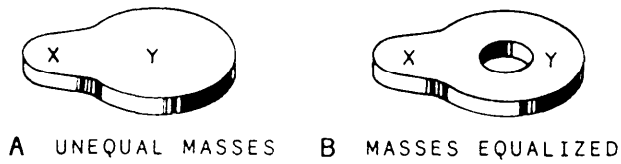


Figure 15-20.—Design of a cam. A. Unequal masses not satisfactory for heat treatment. B. Equalized masses satisfactory for heat treatment.

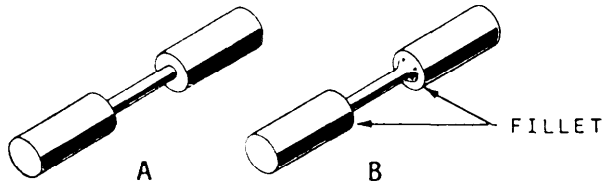


Figure 15-21.—A. Part with unequal masses and sharp corners. B. Use of fillet design to reduce danger of cracking during heat treatment.

with perfect uniformity, since some parts of it must always cool before others. In a well-designed piece, however, the cooling is as uniform as possible for a piece of that particular composition and size.

For example, consider the cooling of a cube of steel. The surfaces of the cube will cool evenly except at the edges and at the corners. At each edge there are two surfaces that dissipate heat at the same time, and at each corner there are three surfaces. Consequently, the corners cool more rapidly than the edges, and the edges cool more rapidly than the surface areas that are not at the edges or corners. If the rate of cooling is extremely rapid, the difference in cooling rate between corners, edges, and other surface areas could be sufficient to cause cracking.

Unequal masses in a single piece are likely to cause trouble when the piece is heat-treated. View A of figure 15-20 shows a cam that might very well become distorted or cracked during heat treatment because the mass of area X is smaller than the mass of area Y. View B of figure 15-20 shows how the masses of the two areas may be equalized, while still keeping the required shape of the cam. The design shown in view B would not be as likely to distort or crack during heat treatment.

The piece shown in view A of figure 15-21 has two design features that would make heat treatment difficult. First, it has unequal masses; and second, it has sharp junctions where the smaller mass joins the larger end portions. A better design for heat treatment is shown

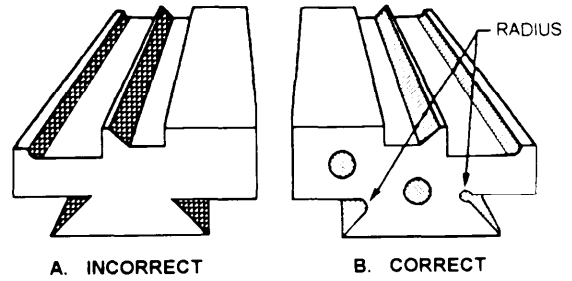


Figure 15-22.—Two designs for undercutting a form tool. A. Poor design. B. Correct design.

in view B of figure 15-21. Although the piece must necessarily have unbalanced masses, the use of a fillet (indicated by an arrow in figure 15-21, view B) at each junction of the smaller and the larger masses would tend to reduce the danger of the piece cracking from heat treatment.

Figure 15-22 shows two designs for undercutting form tools. The design shown in view A does not lend itself to heat treatment because of the combination of heavy and light sections and because of the sharp corners. The design shown in view B corrects both of these errors. The corners have been rounded where possible, and holes have been drilled through the two heaviest sections to make the masses more nearly balanced.

In general, parts that are designed with sharp corners or unequal masses are extremely difficult to heat-treat. When the design cannot be improved, you will have to determine the best way to heat-treat the part to reduce the chances of cracking or distortion.

Even with a poorly designed part, there are two ways in which you can usually reduce the problems of heat-treating. First, you can select the method of cooling that will be safest while still producing the required properties in the metal. For example, flush quenching of some areas might help to solve the problem. And second, you can shield the danger spots by packing them with fire-resistant cloth and sheet steel or other materials to reduce the rate of heating and the rate of cooling in the areas that would otherwise tend to distort or crack. Shielding materials for steel are usually fastened in place with soft iron wire; the wire must have a very low carbon content so it will not become hard and brittle and fall off during the heat treatment. Holes near an outside edge or between an edge and an interior opening are usually packed with asbestos rope.

## **CRACKING**

Cracking during heat treatment may be caused by heating the material unevenly, by heating it to too high a temperature, by soaking it for too long a time, or by quenching it so it cools unevenly. Some steels are given extra preheats to minimize the danger of cracking from uneven heating. Steel that has been overheated or soaked should be allowed to cool in air to room temperature, and then it should be heated to the correct temperature. However, metals and alloys that have been severely overheated cannot be salvaged; they are actually burned, and no amount of subsequent heat treatment can restore them to their original condition.

Uneven cooling is a major cause of cracking, particularly in some steels. Factors that contribute to uneven cooling are poor design, the presence of scale or other material on the surface of the metal, and the presence of gas pockets in various recesses of the part. Scale should usually be removed before the material is quenched. Gas pockets in recesses of the part can be avoided by circulation or agitation of the quenching medium.

Tool steels that have been deformed or worked while cold tend to crack during hardening unless they are fully annealed before the hardening treatment is started. These steels must also be tempered immediately after they are hardened.

## **WARPING**

Any change of shape in the form of a twist or a bend is known as warping. Poor design, uneven heating through the lower temperature range, and uneven cooling are common causes of warping. Preheating tends to minimize the danger of warping from uneven heating. Annealing parts before hardening them will sometimes prevent warping. This is particularly true of parts that are rough machined on one side and smooth ground on the other. Air-hardening steels tends to warp them if they are not protected from drafts while being cooled.

## **SOFT SPOTS**

Soft spots in a hardened piece can usually be traced to the use of the wrong quenching medium, the use of incorrect quenching procedures, the presence of scale on some parts of the surface, or the use of the wrong kind of tongs for handling the material. Soft spots in case-hardened steels are usually caused by packing the pieces so they touch each other.

Soft spots will result when plain water is used as a quenching medium, if the vapor stage of the quench is not broken up. In this stage, air bubbles or air pockets form on the surface of the metal and retard the cooling rate wherever they touch the metal.

## **SIZE CHANGES**

Some permanent change in dimensions may occur during heat treatment. In some cases this change of size is unavoidable. In others it is merely the result of incorrect heat treatment.

Oil-hardened and air-hardened steels tend to shrink during hardening. This size change is normal and cannot be prevented. However, it must be allowed for in the design of any part that must be precisely dimensioned. These steels tend to shrink excessively, more than the normal amount, if they are not heated sufficiently for hardening. They tend to increase in size if they are overheated. Very close control of temperature is necessary for successful heat treatment of these steels.

When metal scales, some of the surface metal is lost. Thus, scaling causes a decrease in size. Scaling can usually be prevented by controlling the furnace atmosphere. If furnaces with controlled atmospheres are not available, a fuels source such as a small block of wood or a small amount of charcoal can be placed in the furnace chamber. This will reduce the oxygen in an electric furnace to about 3%.

Nitrided steels increase in dimension during the nitriding process. This increase in size cannot be prevented, but parts to be nitrided should be machined slightly undersized to allow for the increase.

Steel that has been cold-drawn may undergo a permanent increase in size when it is heated, because cold-drawing leaves the metal highly stressed. The size increase in cold-drawn steel can be avoided by annealing the steel before machining the part to size.

Excessive shrinkage occurs whenever there is a great difference in the cooling rates of the outer and the inner portions of the metal being heat-treated. The flush quenching method should be used to prevent shrinkage of the metal being heat-treated.

## **SPALLING**

Spalling is the surface cracking or flaking of steel. The cracks are usually very shallow, but in severe cases fairly large sections of the surface may peel away.

In carburized steel, spalling is caused by an undesired carbide network which forms of grain boundaries. To prevent in carburized steel, quench the parts immediately upon removing them from the carburized medium if the grains have not increased in size. If there has been an increase in grain size, reheat the metal to its critical temperature of the core and the case. Improper use of grinding wheels and insufficient use of coolant to keep the surface of the metal cool at all times will also cause spalling.

## BLISTERING

Special care must be taken in heat-treating wrought aluminum alloy to prevent blistering. Blistering is caused by overheating and, in some cases, oversoaking. Overheated hardenable aluminum alloys are rendered useless because the eutectic constituent has melted.

## HARDNESS TEST

A number of tests are used to measure the physical properties of metals and to determine whether a metal meets specification requirements. Some of the more common tests are hardness tests, tensile strength tests, shear strength tests, bend tests, fatigue tests, and compression tests. Of primary importance to a Machinery Repairman after heat-treating metal is the hardness test.

Most metals possess some degree of hardness—that is, the ability to resist penetration by another material. Many tests for hardness are used; the simplest is the file hardness test, which will be discussed later in this chapter. While fair estimates of hardness can be made by an experienced worker, more consistent quantitative measurements are obtained with standard hardness testing equipment.

Hardness may be measured by many types of instruments. The most common are the Rockwell and Brinell hardness testers. Other hardness tests include the Vickers, Eberbach, Monotron, Tukon, and Scleroscope. Since there are many tests and the hardness numbers derived are not equivalent, the hardness numbers must be designated according to the test and the scale used in the test. Comparison charts for the various hardness numbers can be found in the current edition of the *Machinery's Handbook*. Since you are more likely to have access to a Rockwell tester than any other, we will discuss this method.

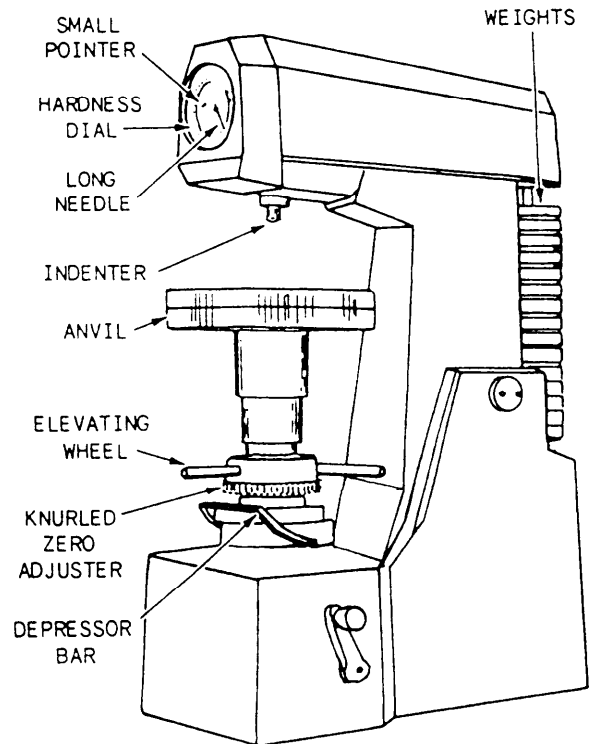


Figure 15-23.—Standard Rockwell hardness testing machine.

## ROCKWELL HARDNESS TEST

Of all the hardness tests, the Rockwell is the one most frequently used. The basic principle of the Rockwell test (like that of the Brinell, Vickers, Eberbach, Tukron, and Monotron tests) is that a hard material will penetrate a softer one. This test operates on the principle of measuring the indentation, in a test piece of metal, made by a ball or cone of a specified size that is being forced against the test piece of metal with specified pressure. In the Rockwell tester, shown in figure 15-23, the hardness number is obtained by measuring the depression made by a hardened steel ball (indenter) or a spheroconical diamond penetrator of a given size under a given pressure.

With the normal Rockwell tester shown, the 120° spheroconical penetrator is used in conjunction with a 150-kilogram (kg) weight to make impressions in hard metals. The hardness number obtained is designated Rockwell C (Rc). For softer metals, the penetrator is a 1/16-inch steel ball used in conjunction with a 100-kg weight. A hardness number obtained under these conditions is designated Rockwell B (Rb).

Figure 15-24 illustrates the principle of indenter hardness tests. Although the conical penetrator is shown, the principle is the same for a ball penetrator.

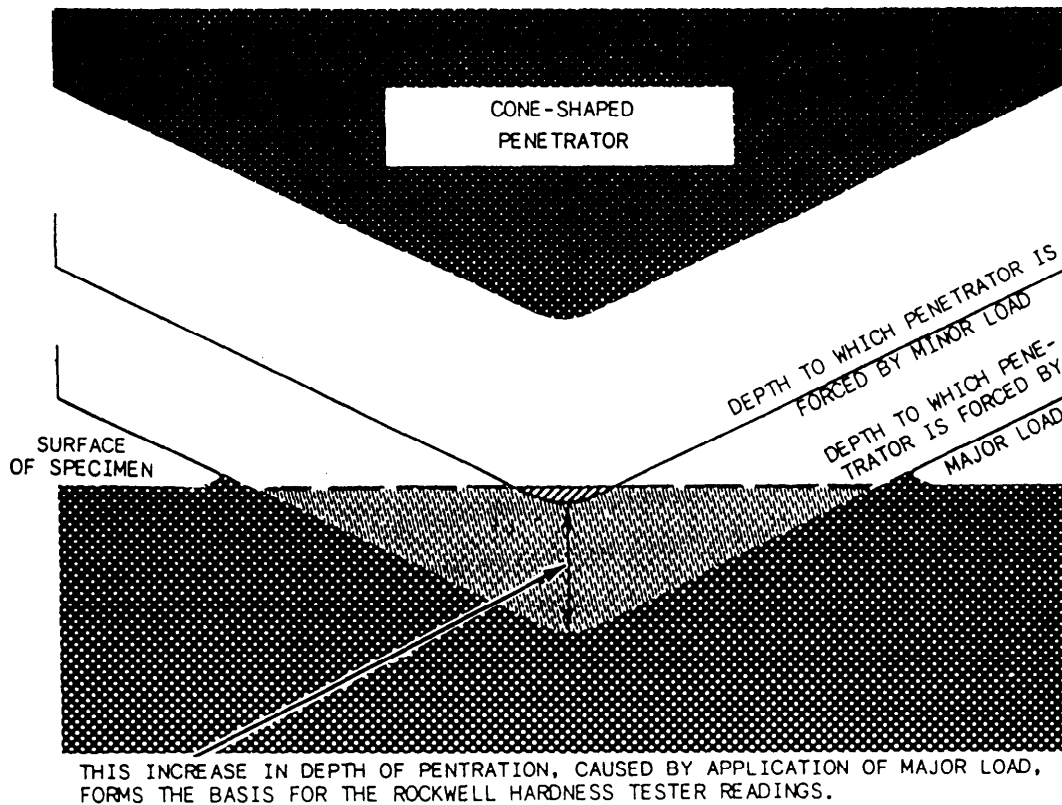


Figure 15-24.—Principle of the Rockwell hardness test.

(The geometry of the indentations will, of course, differ slightly.)

With the Rockwell tester, a deadweight, acting through a series of levers, is used to press the ball or cone into the surface of the metal to be tested. Then, the depth of penetration is measured. The softer the metal being tested, the deeper the penetration will be under a given load. The average depth of penetration on samples of very soft steel is only about 0.008 inch. The hardness is indicated on a dial, calibrated in the Rockwell B and the Rockwell C hardness scales. The harder the metal, the higher the Rockwell number will be. Ferrous metals are usually tested with the spheroconical penetrator, with hardness numbers being read from the Rockwell C scale. The steel ball is used for nonferrous metals, and the results are read on the B scale.

With most indenter-type hardness tests, the metal being tested must be sufficiently thick to avoid bulging or marking the opposite side. The specimen thickness should be at least 10 times the depth of penetration. It is also essential that the surface of the specimen be flat and clean. When hardness tests are necessary on thin material, a superficial Rockwell tester should be used.

The Rockwell superficial tester differs from the normal Rockwell tester in the amount of load applied to perform the test and in the kind of scale used to interpret the results. While the major loads on the normal tester are 100 and 150 kg, the major loads on the superficial tester are 15, 30, and 45 kg. One division on the dial gauge of the normal tester represents a vertical displacement of the indenter of 0.002 millimeter (mm). One division of the dial gauge of the superficial tester represents a vertical displacement of the indenter of 0.001 mm. Hardness scales for the Rockwell superficial tester are the N and T scales. The N scale is used for materials that, if they were thicker, would usually be tested with the normal tester using the C scale. The T scale is comparable to the B scale used with the normal tester. In other respects, the normal and superficial Rockwell testers are much alike.

Once you have prepared your sample for testing, refer to your testers operator manual for step-by-step operating instructions.

### FILE HARDNESS TEST

The simplest method of testing a material's hardness is the file hardness test. This test cannot be



used to make positive identification of metals, but it can be used to get a general idea of the type of metal being tested and to compare the hardness of various metals on hand. Thus, when identification of metals by other means is not possible, you can use a file to determine the relative hardness of various metals. The results of such a test may enable you to select a metal suitable for the job being performed.

The file hardness test is simple to perform. You may hold the metal being tested in your hand and rested on a bench or put it in a vise. Grasp the file with your index finger extended along the file and apply the file slowly but firmly to the surface being tested.

If the material is cut by the file with extreme ease and tends to clog the spaces between the file teeth, it is VERY SOFT. If the material offers some resistance to

the cutting action of the file and tends to clog the file teeth, it is SOFT. If the material offers considerable resistance to the file but can be filed by repeated effort, it is HARD and may or may not have been treated. If the material can be removed only by extreme effort and in small quantities by the file teeth, it is VERY HARD and has probably been heat treated. If the file slides over the material and the file teeth are dulled, the material is EXTREMELY HARD and has been heat-treated.

The file test is not a scientific method. It should not be used when positive identification of metal is necessary or when an accurate measurement of hardness is required. Tests already described should be used for positive identification of metals. Special machines, such as the Rockwell and Brinell testers, should be used when it is necessary to determine accurately the hardness of the material.

## APPENDIX I

# GLOSSARY

**AISI**—American Iron and Steel Institute.

**ABRASIVE**—A hard, tough substance that has many sharp edges.

**ALLOWANCE**—The difference between maximum size limits of mating parts.

**ALLOYING**—The procedure of adding elements other than those usually comprising a metal or alloy to change its characteristics and properties.

**ALLOYING ELEMENTS**—Elements added to nonferrous and ferrous metals and alloys to change their characteristics and properties.

**ANNEALING**—The softening of metal by heating and slow cooling.

**ARBOR**—The principal axis member, or spindle, of a machine by which a motion of revolution is transmitted.

**ASTM**—American Society for Testing Metals.

**BABBITT**—A lead base alloy used for bearings.

**BEND ALLOWANCE**—An additional amount of metal used in a bend in metal fabrication.

**BENCH MOLDING**—The process of making small molds on a bench.

**BEVEL**—A term for a plane having any angle other than 90° to a given reference plane.

**BINARY ALLOY**—An alloy of two metals.

**BISECT**—To divide into two equal parts.

**BLOWHOLE**—A hole in a casting caused by trapped air or gases.

**BOND**—Appropriate substance used to hold grains together in grinding wheels.

**BORING BAR**—A tool used for boring, counter-boring, re-boring, facing, grooving, and so forth, where true alignment is of primary importance.

**BRINELL**—A type of hardness test.

**BRITTLENESS**—The property of a material that causes it to break or snap suddenly with little or no prior sign of deformation.

**BRONZE**—A nonferrous alloy composed of copper and tin and sometimes other elements.

**CALIBRATION**—The procedure required to adjust an instrument or device to produce a standardized output with a given input.

**CARBON**—An alloying element.

**CASTING**—A metal object made by pouring melted metal into a mold.

**CHAMFER**—A bevel surface formed by cutting away the angle of one or two intersecting faces of a piece of material.

**CONTOUR**—The outline of a figure or body.

**DRIFT PIN**—A conical-shaped pin gradually tapered from a blunt point to a diameter larger than the hole diameter.

**DUCTILITY**—The ability to be molded or shaped without breaking.

**EXTRACTOR**—Tool used in removal of broken taps.

**FABRICATE**—To shape, assemble, and secure in place component parts to form a complete device.

**FALSE CHUCK**—Sometimes applied to the facing material used in rechucking a piece of work in the lathe.

**FATIGUE**—The tendency of a material to break under repeated strain.

**FILE FINISH**—Finishing a metal surface with a file.

**FILLET**—A concave internal corner in a metal component.

**FINISH ALLOWANCE**—An amount of stock left on the surface of a casting to allow for machine finishing.

**FINISH MARKS**—Marks used to indicate the degree of smoothness of finish to be achieved on surfaces to be machined.

**GRAIN**—The cutting particles of a grinding wheel.

**HARDNESS**—The ability of a material to resist penetration.

**HONING**—Finishing machine operation using stones vice a tool bit or cutting tool.

**INVOLUTE**—Usually referred to as a cutter used in gearing.

**KNOOP**—Trade name used in hardness testing.

**MANDREL**—Tool used to mount work usually done in a lathe or milling machine.

**NORMALIZING**—Heating iron-base alloys to approximately 100°F above the critical temperature range followed by cooling to below that range in still air at room temperature.

**PERPENDICULAR**—A straight line that meets another straight line at a 90 degree angle. Also a vertical line extending through the outline of the hull ends and the designer's waterline.

**PIG IRON**—Cast iron as it comes from the blast furnace in which it was produced from iron ore.

**PINHOLE**—Small hole under the surface of the casting.

**PLAN**—A drawing prepared for use in building a ship.

**PLASTICITY**—The property that enables a material to be excessively and permanently deformed without breaking.

**PREHEATING**—The application of heat to the base metal before it is welded or cut.

**PUNCH, PRICK**—A small punch used to transfer the holes from the template to the plate. Also called a **CENTER PUNCH**.

**QUENCHING**—Rapid cooling of steels at different rates.

**REAMING**—Enlarging a hole by revolving in it a cylindrical, slightly tapered tool with cutting edges running along its sides.

**RECHUCKING**—Reversing of a piece of work on a faceplate so that the surface that was against the faceplate may be turned to shape.

**REFERENCE PLANE**—On a drawing, the normal plane from which all information is referenced.

**RPM**—Revolutions per minute.

**SCALE**—The ratio between the measurement used on a drawing and the measurement of the object it represents. A measuring device such as a ruler, having special graduations.

**SECTOR**—A figure bounded by two radii and the included arc of a circle, ellipse, or other central curve.

**SPOT FACING**—Turning a circular bearing surface about a hole. It does not affect a pattern.

**STANDARD CASING**—The half of a split casing that is bolted to the foundation, as opposed to the half, or cover, which can be removed with minimum disturbance to other elements of the equipment.

**STRAIGHTEDGE**—Relatively long piece of material whose working edge is a true plane.

**STRENGTH**—The ability of a material to resist strain.

**STRESS RELIEVING**—Heat treatment to remove stresses or casting strains.

**STUD**—(1) A light vertical structure member, usually of wood or light structural steel, used as part of a wall and for supporting moderate loads. (2) A bolt threaded on both ends, one end of which is screwed into a hole drilled and tapped in the work, and used where a through bolt cannot be fitted.

**SYNTHETIC MATERIAL**—A complex chemical compound that is artificially formed by the combining of two or more simpler compounds or elements.

**TEMPER**—To relieve internal stress by heat treating.

**TEMPLATE**—A pattern used to reproduce parts.

**TOLERANCE**—An allowable variation in the dimensions of a machined part.

**VICKERS**—A scale or test used in metal hardness testing.

**VITRIFIED BOND**—A man-made bond used in grinding wheels.

**WAVINESS**—Used as a term in the testing finish machining of parts.

**ZINC**—An alloy used widely in die casting.

## APPENDIX II

# TABULAR INFORMATION OF BENEFIT TO A MACHINERY REPAIRMAN

Table AII-1.—Decimal Equivalents of Fractions (inch)

frac- tions	# 64ths	# 32ds	# 16ths	# 8ths	# 4ths	decimal equiv.	frac- tions	# 64ths	# 32ds	# 16ths	# 8ths	# 4ths	decimal equiv.
$\frac{1}{64}$	1					0.015625	$\frac{33}{64}$	33					0.515625
$\frac{1}{32}$	2	1				0.03125	$\frac{17}{32}$	34	17				0.53125
$\frac{3}{64}$	3					0.046875	$\frac{35}{64}$	35					0.546875
$\frac{1}{16}$	4	2	1			0.0625	$\frac{9}{16}$	36	18	9			0.5625
$\frac{5}{64}$	5					0.078125	$\frac{37}{64}$	37					0.578125
$\frac{3}{32}$	6	3				0.09375	$\frac{19}{32}$	38	19				0.59375
$\frac{7}{64}$	7					0.109375	$\frac{39}{64}$	39					0.609375
$\frac{1}{8}$	8	4	2	1		0.125	$\frac{5}{8}$	40	20	10	5		0.625
$\frac{9}{64}$	9					0.140625	$\frac{41}{64}$	41					0.640625
$\frac{5}{32}$	10	5				0.15625	$\frac{21}{32}$	42	21				0.65625
$\frac{11}{64}$	11					0.171875	$\frac{43}{64}$	43					0.671875
$\frac{3}{16}$	12	6	3			0.1875	$\frac{11}{16}$	44	22	11			0.6875
$\frac{13}{64}$	13					0.203125	$\frac{45}{64}$	45					0.703125
$\frac{7}{32}$	14	7				0.21875	$\frac{23}{32}$	46	23				0.71875
$\frac{15}{64}$	15					0.234375	$\frac{47}{64}$	47					0.734375
$\frac{1}{4}$	16	8	4	2	1	0.250	$\frac{3}{4}$	48	24	12	6	3	0.750
$\frac{17}{64}$	17					0.265625	$\frac{49}{64}$	49					0.765625
$\frac{9}{32}$	18	9				0.28125	$\frac{25}{32}$	50	25				0.78125
$\frac{19}{64}$	19					0.296875	$\frac{51}{64}$	51					0.796875
$\frac{5}{16}$	20	10	5			0.3125	$\frac{13}{16}$	52	26	13			0.8125
$\frac{21}{64}$	21					0.328125	$\frac{53}{64}$	53					0.828125
$\frac{11}{32}$	22	11				0.34375	$\frac{27}{32}$	54	27				0.84375
$\frac{23}{64}$	23					0.359375	$\frac{55}{64}$	55					0.859375
$\frac{3}{8}$	24	12	6	3		0.375	$\frac{7}{8}$	56	28	14	7		0.875
$\frac{25}{64}$	25					0.390625	$\frac{57}{64}$	57					0.890625
$\frac{13}{32}$	26	13				0.40625	$\frac{29}{32}$	58	29				0.90625
$\frac{27}{64}$	27					0.421875	$\frac{59}{64}$	59					0.921875
$\frac{7}{16}$	28	14	7			0.4375	$\frac{15}{16}$	60	30	15			0.9375
$\frac{29}{64}$	29					0.453125	$\frac{61}{64}$	61					0.953125
$\frac{15}{32}$	30	15				0.46875	$\frac{31}{32}$	62	31				0.96875
$\frac{31}{64}$	31					0.484375	$\frac{63}{64}$	63					0.984375
$\frac{1}{2}$	32	16	8	4	2	0.500	1 inch	64	32	16	8	4	1.000

Table AII-2.—Decimal Equivalents of Millimeters

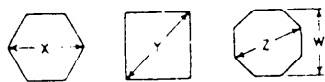
mm	inches	mm	inches	mm	inches	mm	inches	mm	inches
0.1	0.00394	3.5	0.13779	6.9	0.27165	10.3	0.40551	13.8	0.54330
0.2	0.00787	3.6	0.14173	7.0	0.27559	10.4	0.40944	13.9	0.54724
0.3	0.01181	3.7	0.14566	7.1	0.27952	10.5	0.41388	14.0	0.55118
0.4	0.01575	3.8	0.14960	7.2	0.28346	10.6	0.41732	14.1	0.55511
0.5	0.01968	3.9	0.15354	7.3	0.28740	10.7	0.42125	14.2	0.55905
0.6	0.02362	4.0	0.15748	7.4	0.29133	10.8	0.42519	14.3	0.56299
0.7	0.02756	4.1	0.16141	7.5	0.29527	10.9	0.42913	14.4	0.56692
0.8	0.03149	4.2	0.16535	7.6	0.29921	11.0	0.43307	14.5	0.57086
0.9	0.03543	4.3	0.16929	7.7	0.30314	11.1	0.43700	14.6	0.57480
1.0	0.03937	4.4	0.17322	7.8	0.30708	11.2	0.44094	14.7	0.57873
1.1	0.04330	4.5	0.17716	7.9	0.31102	11.3	0.44488	14.8	0.58267
1.2	0.04724	4.6	0.18110	8.0	0.31496	11.4	0.44881	14.9	0.58661
1.3	0.05118	4.7	0.18503	8.1	0.31889	11.5	0.45275	15.0	0.59055
1.4	0.05512	4.8	0.18897	8.2	0.32283	11.6	0.45669	15.5	0.61023
1.5	0.05905	4.9	0.19291	8.3	0.32677	11.7	0.46062	16.0	0.62992
1.6	0.06299	5.0	0.19685	8.4	0.33070	11.8	0.46456	16.5	0.64960
1.7	0.06692	5.1	0.20078	8.5	0.33464	11.9	0.46850	17.0	0.66929
1.8	0.07086	5.2	0.20472	8.6	0.33858	12.0	0.47244	17.5	0.68897
1.9	0.07480	5.3	0.20866	8.7	0.34251	12.1	0.47637	18.0	0.70866
2.0	0.07874	5.4	0.21259	8.8	0.34645	12.2	0.48031	18.5	0.72834
2.1	0.08267	5.5	0.21653	8.9	0.35039	12.3	0.48425	19.0	0.74803
2.2	0.08661	5.6	0.22047	9.0	0.35433	12.4	0.48818	19.5	0.76771
2.3	0.09055	5.7	0.22440	9.1	0.35826	12.5	0.49212	20.0	0.78740
2.4	0.09448	5.8	0.22834	9.2	0.36220	12.6	0.49606	20.5	0.80708
2.5	0.09842	5.9	0.23228	9.3	0.36614	12.7	0.49999	21.0	0.82677
2.6	0.10236	6.0	0.23622	9.4	0.37007	12.8	0.50393	21.5	0.84645
2.7	0.10629	6.1	0.24015	9.5	0.37401	12.9	0.50787	22.0	0.86614
2.8	0.11023	6.2	0.24409	9.6	0.37795	13.0	0.51181	22.5	0.88582
2.9	0.11417	6.3	0.24803	9.7	0.38188	13.1	0.51574	23.0	0.90551
3.0	0.11811	6.4	0.25196	9.8	0.38582	13.2	0.51968	23.5	0.92519
3.1	0.12204	6.5	0.25590	9.9	0.38976	13.3	0.52362	24.0	0.94488
3.2	0.12598	6.6	0.25984	10.0	0.39370	13.4	0.52755	24.5	0.96456
3.3	0.12992	6.7	0.26377	10.1	0.39763	13.5	0.53149	25.0	0.98425
3.4	0.13385	6.8	0.26771	10.2	0.40157	13.6	0.53543	25.5	1.00393
				10.3	0.40551	13.7	0.53936	26.0	1.02362

Table AII-3.—Dividing a Circle into Parts

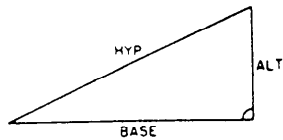
To find the length of the chord for dividing the circumference of a circle into a required number of equal parts, multiply the factor in the table by the diameter.

no. of spaces	chord length	no. of spaces	chord length	no. of spaces	chord length
3	0.866	21	0.149	39	0.0805
4	0.7071	22	0.1423	40	0.0785
5	0.5878	23	0.1362	41	0.0765
6	0.5	24	0.1305	42	0.0747
7	0.4339	25	0.1253	43	0.073
8	0.3827	26	0.1205	44	0.0713
9	0.342	27	0.1161	45	0.0698
10	0.309	28	0.112	46	0.0682
11	0.2818	29	0.1081	47	0.0668
12	0.2584	30	0.1045	48	0.0654
13	0.2393	31	0.1012	49	0.0641
14	0.2224	32	0.098	50	0.0628
15	0.2079	33	0.0951	51	0.0616
16	0.1951	34	0.0932	52	0.0604
17	0.1837	35	0.0896	53	0.0592
18	0.1736	36	0.0872	54	0.0581
19	0.1645	37	0.0848	55	0.0571
20	0.1564	38	0.0826		

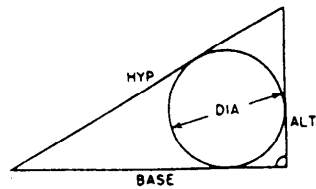
Table AII-4.—Formulas for Dimension, Area, and Volume



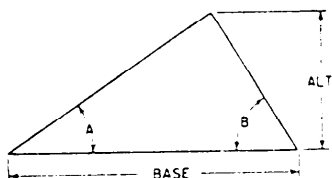
W = WIDTH  
 $X = 1.1547 W$   
 $Y = 1.4142 W$   
 $Z = 1.0824 W$



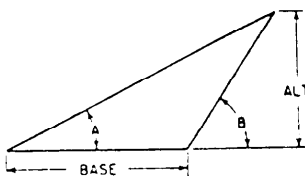
$HYP = \sqrt{BASE^2 + ALT^2}$   
 $BASE = \sqrt{HYP^2 - ALT^2}$   
 $ALT = \sqrt{HYP^2 - BASE^2}$



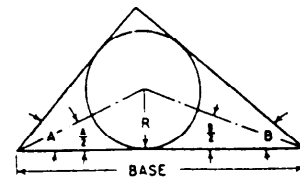
$DIA = BASE + ALT - HYP$



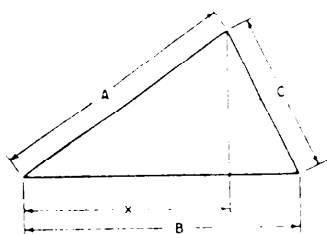
$ALT = \frac{BASE}{\cot A + \cot B}$



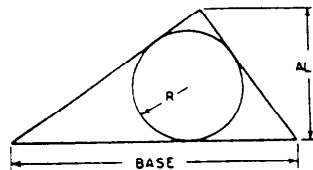
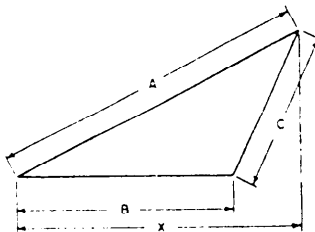
$ALT = \frac{BASE}{\cot A - \cot B}$



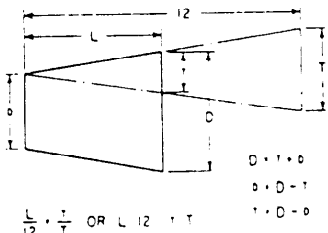
$RAD = \frac{BASE}{\cot \frac{A}{2} + \cot \frac{B}{2}}$



$x = \frac{A^2 + B^2 - C^2}{2B}$

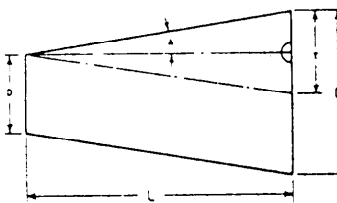


$R = \frac{BASE \times ALT}{PERIMETER}$

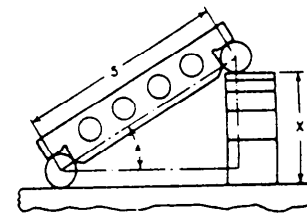


$\frac{L}{12} = \frac{T}{Y}$  OR  $L = 12 \frac{T}{Y}$

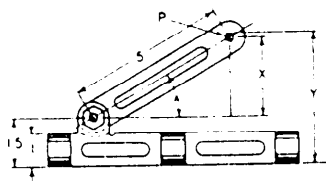
$D = T + d$   
 $d = D - T$   
 $T = D - d$



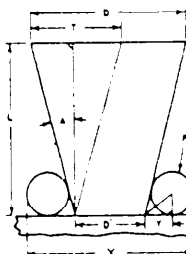
$T = D - d$        $TAN \angle A = \frac{T}{2L}$



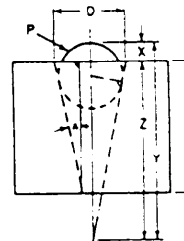
$X = S \times \text{SINE OF } \angle A$



$A = \text{INCLUDED } \angle$        $P = \text{PLUG SIZE}$   
 $X = S \times \text{SINE INC } \angle$        $Y = X + 15 = \frac{P}{2}$



$P = \text{PLUG SIZE}$   
 $T = \text{TAPER PER FT}$   
 $\frac{T}{24} = TAN \angle A$   
 $Y = 2(L \times TAN \angle A)$   
 $d = D - T$   
 $Y = \frac{P}{2} \times \cot \frac{90 - A}{2}$   
 $X = d + 2T + P$



$TAN \angle A = \frac{T}{24}$   
 $Y = \left(\frac{P}{2} \text{ CSC } \angle A\right) + \frac{P}{2}$   
 $Z = \frac{D}{2} \cot \angle A$   
 $X = Y - Z$

Table AII-4.—Formulas for Dimension, Area, and Volume—Continued

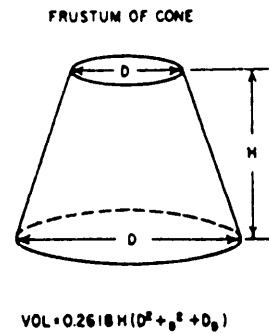
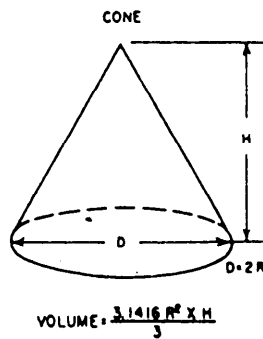
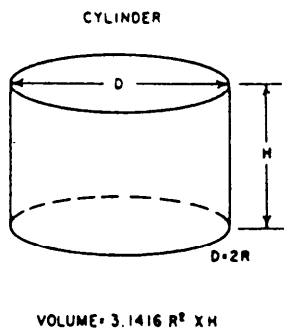
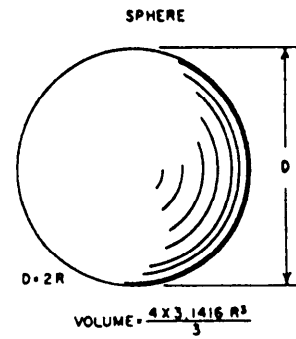
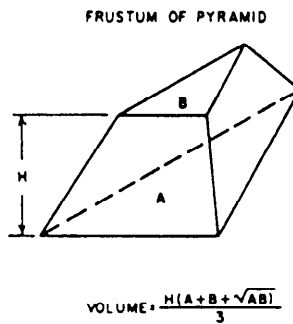
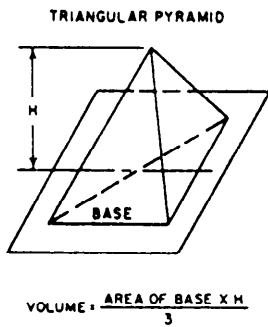
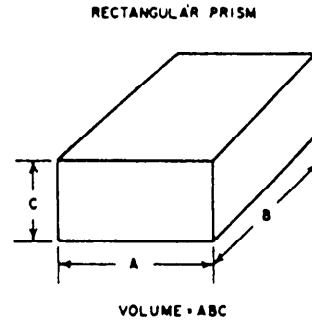
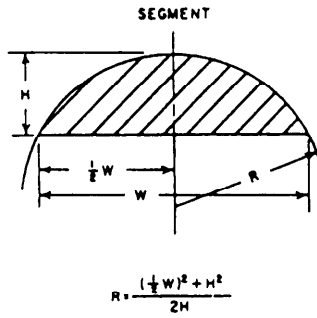
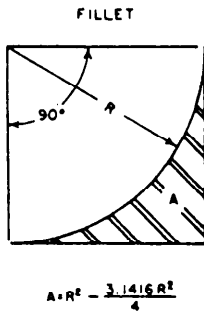
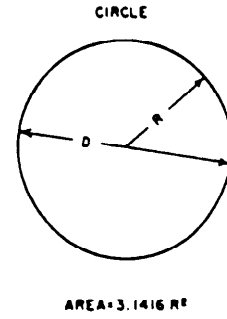
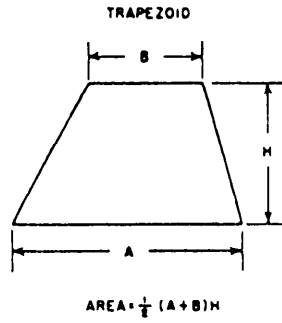
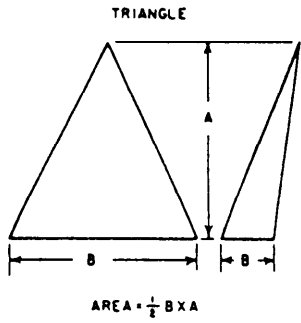




Table AII-5.—Number, Letter and Fractional Identification of Drill Sizes (Letter drills are larger than number drills; they begin where number drills end.)

no. & letter drills	fractional drills	decimal equiv.	no. & letter drills	fractional drills	decimal equiv.	no. & letter drills	fractional drills	decimal equiv.	no. & letter drills	fractional drills	decimal equiv.
80	...	.0135	42	...	.0935		$1\frac{3}{64}$	.2031		$1\frac{3}{32}$	.4062
79	...	.0145		$\frac{3}{32}$	.0937	6	...	.2040	Z	...	.4130
	$\frac{1}{64}$	.0156	41	...	.0960	5	...	.2055		$2\frac{7}{64}$	.4219
78	...	.0160	40	...	.0980	4	...	.2090		$\frac{7}{16}$	.4375
77	...	.0180	39	...	.0995	3	...	.2130		$2\frac{9}{64}$	.4531
76	...	.0200	38	...	.1015		$\frac{7}{32}$	.2187		$1\frac{5}{32}$	.4687
75	...	.0210	37	...	.1040	2	...	.2210		$3\frac{1}{64}$	.4844
74	...	.0225	36	...	.1065	1	...	.2280		$\frac{1}{2}$	.5000
73	...	.0240		$\frac{7}{64}$	.1094	A	...	.2340			
72	...	.0250	35	...	.1100		$1\frac{5}{64}$	.2344		$3\frac{3}{64}$	.5156
71	...	.0260	34	...	.1110	B	...	.2380		$1\frac{7}{32}$	.5312
70	...	.0280	33	...	.1130	C	...	.2420		$3\frac{5}{64}$	.5469
69	...	.0292	32	...	.1160	D	...	.2460		$\frac{9}{16}$	.5625
68	...	.0310	31	...	.1200	E	$\frac{1}{4}$	.2500		$3\frac{7}{64}$	.5781
	$\frac{1}{32}$	.0312		$\frac{1}{8}$	.1250	F	...	.2570		$1\frac{9}{32}$	.5937
67	...	.0320	30	...	.1285	G	...	.2610		$3\frac{9}{64}$	.6094
66	...	.0330	29	...	.1360		$1\frac{7}{64}$	.2656		$\frac{5}{8}$	.6250
65	...	.0350	28	...	.1405	H	...	.2660		$4\frac{1}{64}$	.6406
64	...	.0360		$\frac{9}{64}$	.1406	I	...	.2720		$2\frac{1}{32}$	.6562
63	...	.0370	27	...	.1440	J	...	.2770		$4\frac{3}{64}$	.6719
62	...	.0380	26	...	.1470	K	...	.2810		$1\frac{1}{16}$	.6875
61	...	.0390	25	...	.1495		$\frac{9}{32}$	.2812		$4\frac{5}{64}$	.7031
60	...	.0400	24	...	.1520	L	...	.2900		$2\frac{3}{32}$	.7187
59	...	.0410	23	...	.1540	M	...	.2950		$4\frac{7}{64}$	.7344
58	...	.0420		$\frac{5}{32}$	.1562		$1\frac{9}{64}$	.2969		$\frac{3}{4}$	.7500
57	...	.0430	22	...	.1570	N	...	.3020			
56	...	.0465	21	...	.1590		$\frac{5}{16}$	.3125		$4\frac{9}{64}$	.7656
	$\frac{3}{64}$	.0469	20	...	.1610	O	...	.3160		$2\frac{5}{32}$	.7812
55	...	.0520	19	...	.1660	P	...	.3230		$5\frac{1}{64}$	.7969
54	...	.0550	18	...	.1695		$2\frac{1}{64}$	.3281		$1\frac{3}{16}$	.8125
53	...	.0595		$1\frac{1}{64}$	.1719	Q	...	.3320		$5\frac{3}{64}$	.8281
	$\frac{1}{16}$	.0625	17	...	.1720	R	...	.3390		$2\frac{7}{32}$	.8437
52	...	.0635	16	...	.1770		$1\frac{1}{32}$	.3437		$5\frac{5}{64}$	.8594
51	...	.0670	15	...	.1800	S	...	.3480		$\frac{7}{8}$	.8750
50	...	.0700	14	...	.1820	T	...	.3580			
49	...	.0730	13	...	.1850		$2\frac{3}{64}$	.3594		$5\frac{7}{64}$	.8906
48	...	.0760		$\frac{3}{16}$	.1875	U	...	.3680		$2\frac{9}{32}$	.9062
	$\frac{5}{64}$	.0781	12	...	.1890		$\frac{3}{8}$	.3750		$5\frac{9}{64}$	.9219
47	...	.0785	11	...	.1910	V	...	.3770		$1\frac{5}{16}$	.9375
46	...	.0810	10	...	.1935	W	...	.3860		$6\frac{1}{64}$	.9531
45	...	.0820	9	...	.1960		$2\frac{5}{64}$	.3906		$3\frac{1}{32}$	.9687
44	...	.0860	8	...	.1990	X	...	.3970		$6\frac{3}{64}$	.9844
43	...	.0890	7	...	.2010	Y	...	.4040		1	1.0000

Table AII-6.—Units of Weight, Volume, and Temperature

**AVOIRDUPOIS WEIGHT**

- 16 drams or 437.5 grains = 1 ounce
- 16 ounces or 7,000 grains = 1 pound
- 2,000 pounds = 1 net or short ton
- 2,240 pounds = 1 gross or long ton
- 2,204.6 pounds = 1 metric ton

**BOARD MEASURE**

One board foot measure is a piece of wood 12 inches square by 1 inch thick, or 144 cubic inches. A piece of wood 2 by 4, 12 feet long contains 8 feet board measure.

**DRY MEASURE**

- 2 pints = 1 quart
- 8 quarts = 1 peck
- 4 pecks = 1 bushel
- 1 standard U.S. bushel = 1.2445 cubic feet
- 1 British imperial bushel = 1.2837 cubic feet

**LIQUID MEASURE**

- 4 gills = 1 pint
- 2 pints = 1 quart
- 4 quarts = 1 gallon
- 1 U.S. gallon = 231 cubic inches
- 1 British imperial gallon = 1.2 U.S. gallons
- 7.48 U.S. gallons = 1 cubic foot

**LONG MEASURE**

- 12 inches = 1 foot
- 3 feet = 1 yard
- 1,760 yards = 1 mile
- 5,280 feet = 1 mile
- 16.5 feet = 1 rod

**PAPER MEASURE**

- 24 sheets = 1 quire
- 20 quires = 1 ream
- 2 reams = 1 bundle
- 5 bundles = 1 bale

**SHIPPING MEASURE**

- 1 U.S. shipping ton = 40 cubic feet
- 1 U.S. shipping ton = 32.143 U.S. bushels
- 1 U.S. shipping ton = 31.16 imperial bushels
- 1 British shipping ton = 42 cubic feet
- 1 British shipping ton = 33.75 U.S. bushels
- 1 British shipping ton = 32.718 imperial bushels

**SQUARE MEASURE**

- 144 square inches = 1 square foot
- 9 square feet = 1 square yard
- 30.25 square yards = 1 square rod
- 160 square rods = 1 acre
- 640 acres = 1 square mile

**TEMPERATURE**

- Freezing, Fahrenheit scale = 32 degrees
- Freezing, celcius scale = 0 degrees
- Boiling, Fahrenheit scale = 212 degrees
- Boiling, celcius scale = 100 degrees

If any degree on the celcius scale, either above or below zero, be multiplied by 1.8, the result will, in either case, be the number of degrees above or below 32 degrees Fahrenheit.

**TROY WEIGHT**

- 24 grains = 1 pennyweight
- 20 pennyweights = 1 ounce
- 12 ounces = 1 pound

**WEIGHT OF WATER**

- 1 cubic centimeter = 1 gram or 0.035 ounce
- 1 cubic inch = 0.5787 ounce
- 1 cubic foot = 62.48 pounds
- 1 U.S. gallon = 8.355 pounds
- 1 British imperial gallon = 10 pounds
- 32 cubic feet = 1 net ton (2,000 pounds)
- 35.84 cubic feet = 1 long ton (2,240 pounds)
- 1 net ton = 240 U.S. gallons
- 1 long ton = 268 U.S. gallons

**ENGLISH-METRIC EQUIVALENTS**

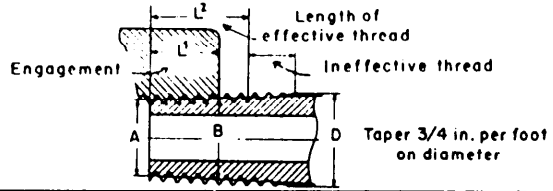
- 1 inch = 2.54 centimeters
- 1 centimeter = 0.3937 inch
- 1 meter = 39.37 inches
- 1 kilometer = 0.62 mile
- 1 quart = 0.946 liter
- 1 U.S. gallon = 3.785 liters
- 1 British gallon = 4.543 liters
- 1 liter = 1.06 quarts
- 1 pound = 0.454 kilogram
- 1 kilogram = 2.205 pounds
- 1 watt = 44.24 foot-pounds per minute
- 1 horsepower = 33,000 foot-pounds per minute
- 1 kilowatt = 1.34 horsepower

Table AII-7.—Screw Thread and Tap Drill Sizes (American National)

screw size	threads per inch		dimensions, inches				tap drill 75% full thread		body drill	decimal equiv.
	NC coarse thread	NF fine thread	major diameter	pitch diameter	single depth of thread	minor diameter	tap drill	decimal equiv.		
0		80	0.060	0.0519	0.00812	0.0438	3/64	0.0469	52	0.0635
1	64		0.073	0.0629	0.01015	0.0527	53	0.0595	47	0.0785
1		72	0.073	0.0640	0.00902	0.0550	53	0.0595	47	0.0785
2	56		0.086	0.0744	0.01160	0.0628	50	0.0700	42	0.0935
2		64	0.086	0.0759	0.01015	0.0657	50	0.0700	42	0.0935
3	48		0.099	0.0855	0.01353	0.0719	47	0.0785	37	0.1040
3		56	0.099	0.0874	0.01160	0.0758	45	0.0820	37	0.1040
4	40		0.112	0.0958	0.01624	0.0795	43	0.0890	31	0.1200
4		48	0.112	0.0985	0.01353	0.0849	42	0.0935	31	0.1200
5	40		0.125	0.1088	0.01624	0.0925	38	0.1015	29	0.1360
5		44	0.125	0.1102	0.01476	0.0955	37	0.1040	29	0.1360
6	32		0.138	0.1177	0.02030	0.0974	36	0.1065	27	0.1440
6		40	0.138	0.1218	0.01624	0.1055	33	0.1130	27	0.1440
8	32		0.164	0.1437	0.02030	0.1234	29	0.1360	18	0.1695
8		36	0.164	0.1460	0.01804	0.1279	29	0.1360	18	0.1695
10	24		0.190	0.1629	0.02706	0.1359	25	0.1495	9	0.1960
10		32	0.190	0.1697	0.02030	0.1494	21	0.1590	9	0.1960
12	24		0.216	0.1889	0.02706	0.1619	16	0.1770	2	0.2210
12		28	0.216	0.1928	0.02320	0.1696	14	0.1820	2	0.2210
1/4	20		0.2500	0.2175	0.03248	0.1850	7	0.2010		
1/4		28	0.2500	0.2268	0.02320	0.2036	3	0.2130		
5/16	18		0.3125	0.2764	0.03608	0.2403	F	0.2570		
5/16		24	0.3125	0.2854	0.02706	0.2584	1	0.2720		
3/8	16		0.3750	0.3344	0.04059	0.2938	5/16	0.3125		
3/8		24	0.3750	0.3479	0.02706	0.3209	Q	0.3320		
7/16	14		0.4375	0.3911	0.04639	0.3447	U	0.3680		
7/16		20	0.4375	0.4050	0.03248	0.3725	29/64	0.3906		
1/2	13		0.5000	0.4500	0.04996	0.4001	27/64	0.4219		
1/2		20	0.5000	0.4675	0.03248	0.4350	29/64	0.4531		
9/16	12		0.5625	0.5084	0.05413	0.4542	31/64	0.4844		
9/16		18	0.5625	0.5264	0.03608	0.4903	33/64	0.5156		
5/8	11		0.6250	0.5660	0.05905	0.5069	17/32	0.5313		
5/8		18	0.6250	0.5889	0.03608	0.5528	37/64	0.5781		
3/4	10		0.7500	0.6850	0.06495	0.6201	21/32	0.6562		
3/4		16	0.7500	0.7094	0.04059	0.6688	11/16	0.6875		
7/8	9		0.8750	0.8028	0.07217	0.7307	49/64	0.7656		
7/8		14	0.8750	0.8286	0.04639	0.7822	13/16	0.8125		
1	8		1.0000	0.9188	0.08119	0.8376	1/4	0.8750		
1		14	1.0000	0.9536	0.04639	0.9072	15/16	0.9375		
1 1/8	7		1.1250	1.0322	0.09279	0.9394	63/64	0.9844		
1 1/8		12	1.1250	1.0709	0.05413	1.0167	17/64	1.0469		
1 1/4	7		1.2500	1.1572	0.09279	1.0644	17/64	1.1094		
1 1/4		12	1.2500	1.1959	0.05413	1.1417	111/64	1.1719		
1 3/8	6		1.3750	1.2667	0.10825	1.1585	17/32	1.2188		
1 3/8		12	1.3750	1.3209	0.05413	1.2667	119/64	1.2969		
1 1/2	6		1.5000	1.3917	0.10825	1.2835	111/32	1.3438		
1 1/2		12	1.5000	1.4459	0.05413	1.3917	127/64	1.4219		
1 3/4	5		1.7500	1.6201	0.12990	1.4902	17/16	1.5625		
2	4 1/2		2.0000	1.8557	0.14434	1.7113	125/32	1.7813		

Table AII-8.—American National Pipe Thread

A = Pitch diameter of thread at end of pipe  
 B = Pitch diameter of thread at gauging notch  
 D = Outside diameter of pipe  
 L<sup>1</sup> = Normal engagement by hand between external and internal thread



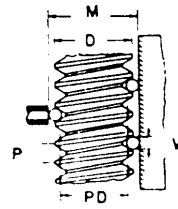
Size Inches	Threads per Inch	Pitch Diameter		Length		Pipe O.D. D Inches	Depth of Thread Inches	Tap Drills for Pipe Threads	
		A Inches	B Inches	L2 Inches	L1 Inches			Minor Diameter Small End of Pipe	Size Drill
1/8	27	.36351	.37476	.2639	.180	.405	.02963	.3339	R
1/4	18	.47739	.48989	.4018	.200	.540	.04444	.4329	3/16
3/8	18	.61201	.62701	.4078	.240	.675	.04444	.5676	1/4
1/2	14	.75843	.77843	.5337	.320	.840	.05714	.7013	5/16
3/4	14	.96768	.98887	.5457	.339	1.050	.05714	.9105	3/8
1	11 1/2	1.21363	1.23863	.6828	.400	1.315	.06957	1.1441	1 1/16
1 1/4	11 1/2	1.55713	1.58338	.7068	.420	1.660	.06957	1.4876	1 1/2
1 1/2	11 1/2	1.79609	1.82234	.7235	.420	1.900	.06957	1.7265	1 3/4
2	11 1/2	2.26902	2.29627	.7565	.436	2.375	.06957	2.1995	2 1/16
2 1/2	8	2.71953	2.76216	1.1375	.682	2.875	.10000	2.6195	2 3/8
3	8	3.34062	3.38850	1.2000	.766	3.500	.10000	3.2406	3 1/4
3 1/2	8	3.83750	3.88881	1.2500	.821	4.000	.10000	3.7375	3 3/4
4	8	4.33438	4.38712	1.3000	.844	4.500	.10000	4.2344	4 1/4

**Table AII-9.—3-Wire Method of Measuring American National Standard Threads**

$$M = D - (1.5166 \times P) + (3 \times W)$$

$$PD - M + \frac{.86603}{\text{No. of thds. per inch}} (3 \times W)$$

To Check Angle  $\frac{M_1 - M_2}{W_1 - W_2}$

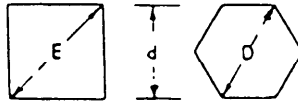


M = Measurement over best size wire.  
 M<sub>1</sub> = Measurement over maximum size wire.  
 M<sub>2</sub> = Measurement over minimum size wire.  
 D = Outside Diameter of Thread.  
 P.D. = Pitch Diameter.  
 W = Diameter Best size wire.  
 W<sub>1</sub> = Diameter maximum size wire.  
 W<sub>2</sub> = Diameter minimum size wire.

0.57735 X pitch  
 0.90 X pitch  
 0.56 X pitch

No. Thds. per inch	Pitch Thds. per inch	Best Wire Size .57735 x Pitch	Maximum Wire Size	Minimum Wire Size
4	.250000	.144337	.225000	.140000
4 ½	.222222	.128300	.200000	.124444
5	.200000	.115470	.180000	.112000
5 ½	.181818	.104969	.163636	.101818
6	.166666	.096224	.149999	.093333
7	.142857	.082478	.128571	.080000
7 ½	.133333	.076979	.120000	.074666
8	.125000	.072168	.112500	.070000
9	.111111	.064149	.100000	.062222
10	.100000	.057735	.090000	.056000
11	.090999	.052486	.081818	.050909
11 ½	.086956	.050204	.078260	.048695
12	.083333	.048112	.075000	.046666
13	.076923	.044411	.069231	.043077
14	.071428	.041239	.064285	.040000
16	.062500	.036084	.056250	.035000
18	.055555	.032074	.050000	.031111
20	.050000	.028867	.045000	.028000
22	.046454	.026242	.040909	.025454
24	.041666	.024055	.037499	.023333
26	.038461	.022205	.034615	.021538
27	.037037	.024383	.033333	.022543
28	.03514	.020620	.032143	.020000
30	.033333	.019244	.030000	.018666
32	.031250	.018042	.028125	.017500
36	.027777	.016037	.024999	.015555
40	.025000	.014433	.022500	.014000
44	.022727	.013121	.020454	.014727
48	.020833	.012027	.018750	.011666
50	.020000	.011547	.018000	.011200
56	.017857	.010309	.016071	.010000

Table AII-10.—Diagonals of Squares and Hexagons



$$E = 1.4142 d$$

$$D = 1.1547 d$$

d	D	E	d	D	E	d	D	E
1/4	0.2886	0.3535	1 1/4	1.4434	1.7677	2 5/16	2.6702	3.2703
3/32	0.3247	0.3977	1 9/32	1.4794	1.8119	2 3/8	2.7424	3.3587
1/8	0.3608	0.4419	1 1/8	1.5155	1.8561	2 7/16	2.8145	3.4471
1 1/32	0.3968	0.4861	1 1 1/32	1.5516	1.9003	2 1/2	2.8867	3.5355
3/8	0.4329	0.5303	1 3/8	1.5877	1.9445	2 9/16	2.9583	3.6239
1 1/32	0.4690	0.5745	1 1 1/32	1.6238	1.9887	2 5/8	3.0311	3.7123
7/16	0.5051	0.6187	1 7/16	1.6598	2.0329	2 1 1/16	3.1032	3.8007
1 5/32	0.5412	0.6629	1 5/32	1.6959	2.0771	2 3/4	3.1754	3.8891
1/2	0.5773	0.7071	1 1/2	1.7320	2.1213	2 1 3/16	3.2476	3.9794
1 7/32	0.6133	0.7513	1 7/32	1.7681	2.1655	2 7/8	3.3197	4.0658
9/16	0.6494	0.7955	1 9/16	1.8042	2.2097	2 1 5/16	3.3919	4.1542
1 9/32	0.6855	0.8397	1 9/32	1.8403	2.2539	3	3.4641	4.2426
5/8	0.7216	0.8839	1 5/8	1.8764	2.2981	3 1/16	3.5362	4.3310
2 1/32	0.7576	0.9281	1 2 1/32	1.9124	2.3423	3 1/8	3.6084	4.4194
1 1/16	0.7937	0.9723	1 1 1/16	1.9485	2.3865	3 1/8	3.6806	4.5078
2 3/32	0.8298	1.0164	1 2 3/32	1.9846	2.4306	3 1/4	3.7527	4.5962
3/4	0.8659	1.0606	1 3/4	2.0207	2.4708	3 5/16	3.8249	4.6846
2 5/32	0.9020	1.1048	1 2 5/32	2.0568	2.5190	3 3/8	3.8971	4.7729
1 3/16	0.9380	1.1490	1 1 3/16	2.0929	2.5632	3 7/16	3.9692	4.8613
2 7/32	0.9741	1.1932	1 2 7/32	2.1289	2.6074	3 1/2	4.0414	4.9497
7/8	1.0102	1.2374	1 7/8	2.1650	2.6516	3 9/16	4.1136	5.0381
2 9/32	1.0463	1.2816	1 2 9/32	2.2011	2.6958	3 5/8	4.1857	5.1265
1 5/16	1.0824	1.3258	1 5/16	2.2372	2.7400	3 1 1/16	4.2579	5.2149
3 1/32	1.1184	1.3700	1 3 1/32	2.2733	2.7842	3 3/4	4.3301	5.3033
1	1.1547	1.4142	2	2.3094	2.8284	3 1 3/16	4.4023	5.3917
1 1/32	1.1907	1.4584	2 1/32	2.3453	2.8726	3 7/8	4.4744	5.4801
1 1/16	1.2268	1.5026	2 1/16	2.3815	2.9168	3 1 5/16	4.5466	5.5684
1 3/32	1.2629	1.5468	2 3/32	2.4176	2.9610	4	4.6188	5.6568
1 1/8	1.2990	1.5910	2 1/8	2.4537	3.0052	4 1/8	4.6910	5.7452
1 5/32	1.3351	1.6352	2 5/32	2.4898	3.0494	4 1/4	4.7632	5.8336
1 3/16	1.3712	1.6793	2 3/16	2.5259	3.0936	4 3/8	4.8354	5.9220
1 7/32	1.4073	1.7235	2 1/4	2.5620	3.1378	4 1/2	4.9076	6.0104

**Table AII-11.—Circles**

Circumference of a circle = diameter  $\times$  3.1416

Diameter of a circle = circumference  $\times$  .31831

Area of a circle = the square of the diameter  $\times$  0.7854

Surface of a ball (sphere) = the square of the diameter  $\times$  3.1416

Side of a square inscribed in a circle = diameter  $\times$  0.70711

Diameter of a circle to circumscribe a square = one side  $\times$  1.4142

Cubic inches (volume) in a ball = cube of the diameter  $\times$  0.5236

When doubled, the diameter of a pipe increases its capacity four times

Radius of a circle  $\times$  6.283185 = circumference

Square of the circumference of a circle  $\times$  0.07958 = area

1/2 circumference of a circle  $\times$  1/2 its diameter = area

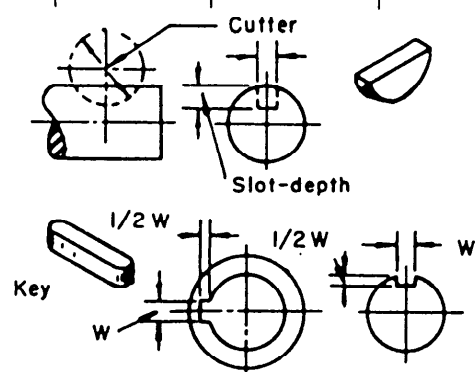
Circumference of a circle  $\times$  .159155 = radius

Square root of the area of a circle  $\times$  0.56419 = radius

Square root of the area of a circle  $\times$  1.12838 = diameter

Table AII-12.—Keyway Dimensions

shaft dia	square keyways	Woodruff keyways*			
		key	thickness	cutter dia	slot depth
0.500	$\frac{1}{8} \times \frac{1}{16}$	404	0.1250	0.500	0.1405
0.562	$\frac{1}{8} \times \frac{1}{16}$	404	0.1250	0.500	0.1405
0.625	$\frac{5}{32} \times \frac{5}{64}$	505	0.1562	0.625	0.1669
0.688	$\frac{3}{16} \times \frac{3}{32}$	606	0.1875	0.750	0.2193
0.750	$\frac{3}{16} \times \frac{3}{32}$	606	0.1875	0.750	0.2193
0.812	$\frac{3}{16} \times \frac{3}{32}$	606	0.1875	0.750	0.2193
0.875	$\frac{7}{32} \times \frac{7}{64}$	607	0.1875	0.875	0.2763
0.938	$\frac{1}{4} \times \frac{1}{8}$	807	0.2500	0.875	0.2500
1.000	$\frac{1}{4} \times \frac{1}{8}$	808	0.2500	1.000	0.3130
1.125	$\frac{5}{16} \times \frac{5}{32}$	1009	0.3125	1.125	0.3228
1.250	$\frac{5}{16} \times \frac{5}{32}$	1010	0.3125	1.250	0.3858
1.375	$\frac{3}{8} \times \frac{3}{16}$	1210	0.3750	1.250	0.3595
1.500	$\frac{3}{8} \times \frac{3}{16}$	1212	0.3750	1.500	0.4535
1.625	$\frac{3}{8} \times \frac{3}{16}$	1212	0.3750	1.500	0.4535
1.750	$\frac{7}{16} \times \frac{7}{32}$				
1.875	$\frac{1}{2} \times \frac{1}{4}$				
2.000	$\frac{1}{2} \times \frac{1}{4}$				
2.250	$\frac{5}{8} \times \frac{5}{16}$				
2.500	$\frac{5}{8} \times \frac{5}{16}$				
2.750	$\frac{3}{4} \times \frac{3}{8}$				
3.000	$\frac{3}{4} \times \frac{3}{8}$				
3.250	$\frac{3}{4} \times \frac{3}{8}$				
3.500	$\frac{3}{8} \times \frac{7}{16}$				
4.000	$1 \times \frac{1}{2}$				

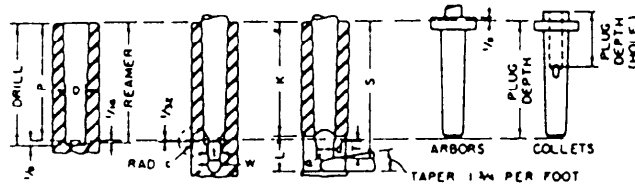


\*The depth of a Woodruff keyway is measured from the edge of the slot.



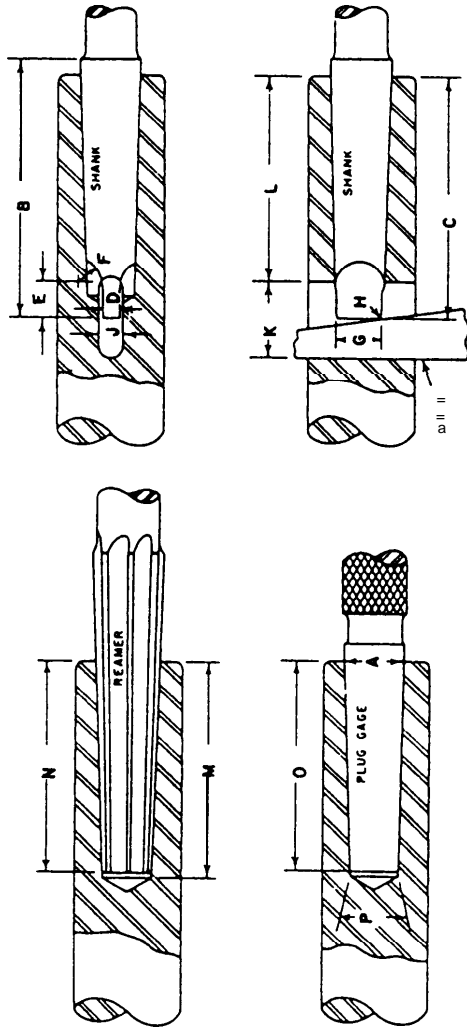


Table AII-14.—Taper in Inches (Brown and Sharpe)



taper no.	taper per foot	plug dia. at small end, D	plug depth (P)			keyway from end of spindle, K	shank depth, S	keyway length, L	keyway width, W	arbor tongue length, T	arbor tongue dia., d	arbor tongue thickness, t	tongue circle radius, c	tongue radius, a	limit for tongue to project through test tool
			B & S stand.	for mill mach.	misc.										
1	0.50200	0.20000	1/16			1/16	1 1/16	1/2	0.135	1/16	0.170	1/2	1/16	0.030	0.003
2	0.50200	0.25000	1/16			1 1/16	1 1/2	1/2	0.166	1/8	0.220	3/32	1/16	0.030	0.003
3	0.50200	0.31250	1/2		1 1/4	1 1/32	1 1/8	3/8	0.197	1/16	0.282	1/16	1/16	0.040	0.003
						1 1/32	2 1/8	1/2	0.197	1/16	0.282	1/16	1/16	0.040	0.003
4	0.50240	0.35000	1 1/16	1 1/4		1 1/4	1 1/32	1 1/16	0.228	1 1/32	0.320	1/32	1/16	0.050	0.003
						1 1/4	2 1/32	1 1/16	0.228	1 1/32	0.320	1/32	1/16	0.050	0.003
5	0.50160	0.45000	2 1/4	1 3/4	2	1 1/16	2 1/16	1/2	0.260	1/2	0.420	1/2	1/16	0.060	0.003
						2 1/16	2 1/16	1/2	0.260	1/2	0.420	1/2	1/16	0.060	0.003
6	0.50329	0.50000	2 1/4			2 1/4	2 1/8	1/2	0.291	1/16	0.460	3/32	1/16	0.060	0.005
7	0.50147	0.60000	2 3/4	3	2 1/2	2 1/32	3 1/32	1 1/16	0.322	1 1/32	0.560	1/16	1/2	0.070	0.005
						2 1/32	3 1/32	1 1/16	0.322	1 1/32	0.560	1/16	1/2	0.070	0.005
8	0.50100	0.75000	3 1/8			3 1/4	4 1/8	1	0.353	1/2	0.710	1 1/32	1/2	0.080	0.005
9	0.50085	0.90010	4 1/4	4		3 1/2	4 1/2	1 1/8	0.385	1/16	0.860	3/8	1/16	0.100	0.005
10	0.51612	1.04485	5	5 1/16		4 1/32	5 1/32	1 1/16	0.447	2 1/32	1.010	1/16	1/16	0.110	0.005
						5 1/32	6 1/32	1 1/16	0.447	2 1/32	1.010	1/16	1/16	0.110	0.005
11	0.50100	1.24995	5 1/16	6 1/4		5 1/32	6 1/32	1 1/16	0.447	2 1/32	1.210	1/16	1/2	0.130	0.005
						6 1/32	7 1/32	1 1/16	0.447	2 1/32	1.210	1/16	1/2	0.130	0.005
12	0.49973	1.50010	7 1/4	7 1/4	6 1/4	6 1/16	7 1/16	1 1/2	0.510	1/2	1.460	1/2	1/2	0.150	0.005
13	0.50020	1.75005	7 3/4			7 1/16	8 1/16	1 1/2	0.510	1/2	1.710	1/2	1/2	0.170	0.010
14	0.50000	2.00000	8 1/4	8 1/4		8 1/32	9 1/32	1 1/16	0.572	2 1/32	1.960	1/16	1/2	0.190	0.010
15	0.50000	2.25000	8 3/4			8 1/32	9 1/32	1 1/16	0.572	2 1/32	2.210	1/16	1/2	0.210	0.010
16	0.50000	2.50000	9 1/4			9	10 1/4	1 1/2	0.635	1 1/16	2.450	1/2	1	0.230	0.010
17	0.50000	2.75000	9 3/4												
18	0.50000	3.00000	10 1/4												

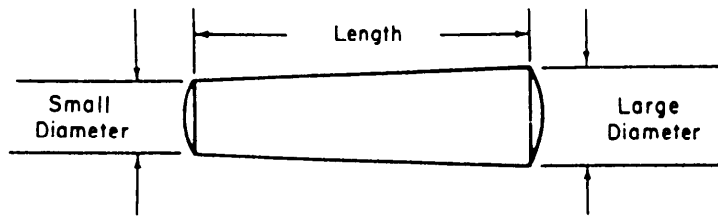
ANSI-A11-15.1 Standard Tapers (Morse)



aper no.	diameter		shank		reamed hole depth, N	drilled hole depth, M	stan. plug depth, O	tang				tang slot			end of socket to tang slot, L	taper per inch	taper per foot	drift no.
	plug at small end, P	gage line, A	whole length, B	depth, C				thick-ness, D	length, E	radius, F	dia, G	radius, H	width, J	length, K				
0	0.252	0.356	2 <sup>11</sup> / <sub>32</sub>	2 <sup>1</sup> / <sub>32</sub>	2 <sup>1</sup> / <sub>32</sub>	2 <sup>1</sup> / <sub>16</sub>	2	3 <sup>1</sup> / <sub>32</sub>	3 <sup>1</sup> / <sub>16</sub>	1 <sup>1</sup> / <sub>4</sub>	3 <sup>1</sup> / <sub>4</sub>	3 <sup>1</sup> / <sub>4</sub>	0.166	3 <sup>1</sup> / <sub>16</sub>	1 <sup>1</sup> / <sub>16</sub>	0.052000	0.62400	0
1	0.369	0.475	2 <sup>7</sup> / <sub>16</sub>	2 <sup>1</sup> / <sub>16</sub>	2 <sup>1</sup> / <sub>16</sub>	2 <sup>1</sup> / <sub>16</sub>	2 <sup>1</sup> / <sub>4</sub>	3 <sup>1</sup> / <sub>16</sub>	3 <sup>1</sup> / <sub>16</sub>	3 <sup>1</sup> / <sub>4</sub>	3 <sup>1</sup> / <sub>4</sub>	0.213	3 <sup>1</sup> / <sub>4</sub>	2 <sup>1</sup> / <sub>16</sub>	2 <sup>1</sup> / <sub>16</sub>	0.049802	0.59858	1
2	0.572	0.700	3 <sup>1</sup> / <sub>4</sub>	2 <sup>1</sup> / <sub>16</sub>	2 <sup>1</sup> / <sub>16</sub>	2 <sup>1</sup> / <sub>16</sub>	2 <sup>7</sup> / <sub>16</sub>	3 <sup>1</sup> / <sub>16</sub>	3 <sup>1</sup> / <sub>16</sub>	3 <sup>1</sup> / <sub>4</sub>	3 <sup>1</sup> / <sub>4</sub>	0.250	3 <sup>1</sup> / <sub>4</sub>	2 <sup>1</sup> / <sub>16</sub>	2 <sup>1</sup> / <sub>16</sub>	0.049551	0.59941	2
3	0.778	0.938	3 <sup>1</sup> / <sub>4</sub>	3 <sup>1</sup> / <sub>16</sub>	3 <sup>1</sup> / <sub>16</sub>	3 <sup>1</sup> / <sub>16</sub>	3 <sup>1</sup> / <sub>16</sub>	3 <sup>1</sup> / <sub>16</sub>	3 <sup>1</sup> / <sub>16</sub>	3 <sup>1</sup> / <sub>4</sub>	3 <sup>1</sup> / <sub>4</sub>	0.312	3 <sup>1</sup> / <sub>4</sub>	3 <sup>1</sup> / <sub>16</sub>	3 <sup>1</sup> / <sub>16</sub>	0.050196	0.60235	3
4	1.020	1.231	4 <sup>1</sup> / <sub>4</sub>	4 <sup>1</sup> / <sub>16</sub>	4 <sup>1</sup> / <sub>16</sub>	4 <sup>1</sup> / <sub>16</sub>	4 <sup>1</sup> / <sub>16</sub>	4 <sup>1</sup> / <sub>16</sub>	3 <sup>1</sup> / <sub>16</sub>	3 <sup>1</sup> / <sub>2</sub>	3 <sup>1</sup> / <sub>2</sub>	0.469	3 <sup>1</sup> / <sub>2</sub>	3 <sup>1</sup> / <sub>16</sub>	3 <sup>1</sup> / <sub>16</sub>	0.051938	0.62326	4
5	1.475	1.748	5 <sup>1</sup> / <sub>4</sub>	5 <sup>1</sup> / <sub>16</sub>	5 <sup>1</sup> / <sub>16</sub>	5 <sup>1</sup> / <sub>16</sub>	5 <sup>1</sup> / <sub>16</sub>	5 <sup>1</sup> / <sub>16</sub>	3 <sup>1</sup> / <sub>16</sub>	3 <sup>1</sup> / <sub>2</sub>	3 <sup>1</sup> / <sub>2</sub>	0.625	3 <sup>1</sup> / <sub>2</sub>	4 <sup>1</sup> / <sub>16</sub>	4 <sup>1</sup> / <sub>16</sub>	0.052626	0.63151	5
6	2.116	2.494	6 <sup>1</sup> / <sub>4</sub>	8 <sup>1</sup> / <sub>16</sub>	7 <sup>1</sup> / <sub>32</sub>	7 <sup>1</sup> / <sub>32</sub>	7 <sup>1</sup> / <sub>4</sub>	7 <sup>1</sup> / <sub>4</sub>	3 <sup>1</sup> / <sub>16</sub>	3 <sup>1</sup> / <sub>2</sub>	3 <sup>1</sup> / <sub>2</sub>	0.750	3 <sup>1</sup> / <sub>2</sub>	7	7	0.052137	0.62565	5*
7	2.750	3.270	11 <sup>1</sup> / <sub>2</sub>	11 <sup>1</sup> / <sub>16</sub>	10 <sup>1</sup> / <sub>32</sub>	10 <sup>1</sup> / <sub>32</sub>	10	1.125	1 <sup>1</sup> / <sub>16</sub>	2 <sup>1</sup> / <sub>16</sub>	2 <sup>1</sup> / <sub>16</sub>	1.135	2 <sup>1</sup> / <sub>16</sub>	9 <sup>1</sup> / <sub>2</sub>	9 <sup>1</sup> / <sub>2</sub>	0.052000	0.62400	5*

\* Dimensions agree essentially with those of the American Standard on Machine Tapers  
 † The No. 5 drift will also eject No. 6 taper shank tools

Table AII-16.—Drill Sizes for Taper Pins



Drill size should be approximately 0.005 smaller than small diameter

Taper = 1/4 in. per foot

$$\text{Small diameter} = \text{large diameter} - \text{length} \times 0.02083$$

NUMBER	7/0	6/0	5/0	4/0	3/0	2/0	0	1	2	3	4	5	6	7	8	9	10	11			
<b>DIAMETER AT LARGE</b>																					
END	0.0625	0.070	0.084	0.100	0.125	0.141	0.156	0.172	0.193	0.219	0.250	0.289	0.341	0.400	0.482	0.591	0.707	0.857	1/4		
<b>LENGTH</b>																					
	<b>DIAMETER OF SMALL END OF PIN AND DRILL SIZE</b>																	<b>LENGTH</b>			
1/4	0.0573	0.0720																		1/4	
	34	50																			3/8
1/2	0.0547	0.0702	0.0862																		1/2
	56	51	45																		
3/4	0.0521	0.0676	0.0836	0.0986	0.1146	0.1306	0.1458	0.1616													
	58	52	46	41	34	30	1/4	1/2													
1	0.0495	0.0650	0.0810	0.0960	0.1120	0.1280	0.1430	0.1580													
	56	52	1/2	1/2	1/2	1/2	1/2	23													
1 1/4	0.0489	0.0624	0.0784	0.0934	0.1094	0.1254	0.1404	0.1564	0.1774	0.2034	0.2344										
	56	53	48	43	36	31	29	24	1 1/4	8	1										
1 1/2		0.0598	0.0758	0.0908	0.1068	0.1228	0.1378	0.1538	0.1748	0.2008	0.2318										
		54	49	43	37	31	29	25	18	9	1										
1 3/4		0.0572	0.0732	0.0882	0.1042	0.1202	0.1352	0.1512	0.1722	0.1982	0.2292	0.2602	0.3202								
		54	50	44	38	32	30	26	19	10	2	0	0								
2				0.0856	0.1016	0.1176	0.1326	0.1486	0.1696	0.1956	0.2266	0.2656	0.3176								
				45	39	33	30	27	19	11	2	0	1/4								
2 1/4				0.0830	0.0990	0.1150	0.1300	0.1460	0.1670	0.1930	0.2240	0.2630	0.3150	0.3830							
				46	41	33	1/4	1/4	20	1/4	1/2	F	M	1/4							
2 1/2				0.0984	0.1124	0.1274	0.1434	0.1644	0.1904	0.2214	0.2604	0.3124	0.3804								
				1/2	1/4	1/4	1/4	20	1/4	3	F	M	1/4								
2 3/4				0.0938	0.1098	0.1248	0.1408	0.1618	0.1878	0.2188	0.2578	0.3098	0.3778	0.4608							
				43	36	31	28	1/2	14	3	1/4	M	U	1 1/4							
3				0.1045	0.1195	0.1355	0.1565	0.1825	0.2135	0.2525	0.3045	0.3725	0.4555								
				38	32	30	24	18	4	D	1 1/4	U	1 1/4								
3 1/4				0.0993	0.1143	0.1303	0.1513	0.1773	0.2203	0.2473	0.2893	0.3673	0.4803	0.6404							
				41	34	1/4	26	1 1/4	1 1/4	C	M	1 1/4	1/4	1 1/4							
3 1/2							0.1251	0.1461	0.1721	0.2031	0.2421	0.2941	0.3621	0.4451	0.5442						
							31	27	18	8	B	L	T	1/4	1 1/4						
3 3/4							0.1199	0.1409	0.1669	0.1979	0.2369	0.2889	0.3569	0.4399	0.5390	0.6540					
							32	29	20	10	1 1/4	1/2	S	1 1/4	1 1/4	1 1/4					
4							0.1357	0.1617	0.1927	0.2317	0.2837	0.3517	0.4347	0.5338	0.6488						
							38	1/2	1/4	1	J	1 1/4	1 1/4	1 1/4	1 1/4						

Table AII-16.—Drill Sizes for Taper Pins—Continued

NUMBER	7/0	6/0	5/0	4/0	3/0	2/0	0	1	2	3	4	5	6	7	8	9	10	11											
DIAMETER AT LARGE																													
END	0.0625	0.078	0.094	0.109	0.125	0.141	0.156	0.172	0.193	0.219	0.250	0.289	0.341	0.409	0.492	0.591	0.707	0.857	3/4										
LENGTH	DIAMETER OF SMALL END OF PIN AND DRILL SIZE																		LENGTH										
3																			3										
																			30	24	14	2	1	R	27/64	23/64	3/8	25/32	
3 1/4																			0.1823	0.2213	0.2733	0.3413	0.4243	0.5233	0.6383	0.7823	3/4		
																			16	1/32	17/64	Q	Z	23/64	3/8	25/32			
3 1/2																			0.1771	0.2161	0.2681	0.3361	0.4191	0.5181	0.6331	0.7871	3/4		
																			11/64	3	G	Q	13/32	1/2	3/8	25/32			
3 3/4																			0.2629	0.3309	0.4139	0.5129	0.6279	0.7819	3/4				
																			F	21/64	13/32	1/2	23/64	49/64					
4																			0.2577	0.3257	0.4087	0.5077	0.6227	0.7767	4				
																			3/8	P	Y	1/2	23/64	49/64					
4 1/4																			0.3205	0.4035	0.5025	0.6175	0.7715	4 1/4					
																			O	X	21/64	23/64	49/64						
4 1/2																			0.3153	0.3983	0.4973	0.6123	0.7663	4 1/2					
																			1/16	23/64	21/64	13/32	3/8						
4 3/4																			0.3931	0.4921	0.6071	0.7611	4 3/4						
																			W	21/64	13/32	3/8							
5																			0.3879	0.4869	0.6019	0.7559	5						
																			3/8	13/32	13/32	3/8							
5 1/4																			0.4817	0.5967	0.7507	5 1/4							
																			13/32	27/64	47/64								
5 1/2																			0.4765	0.5915	0.7455	5 1/2							
																			13/32	27/64	47/64								
5 3/4																			0.4713	0.5863	0.7403	5 3/4							
																			27/64	27/64	47/64								
6																			0.4660	0.5810	0.7350	6							
																			27/64	3/16	23/32								
6 1/4																			0.5750	0.7290	6 1/4								
																			3/16	23/32									
6 1/2																			0.5706	0.7246	6 1/2								
																			3/16	23/32									
6 3/4																			0.5654	0.7194	6 3/4								
																			21/64	49/64									
7																			0.5602	0.7142	7								
																			21/64	49/64									
7 1/4																			0.7090	7 1/4									
																			49/64										
7 1/2																			0.7038	7 1/2									
																			11/16										

## APPENDIX III

# FORMULAS FOR SPUR GEARING

Having	To Get	Rule	Formula
Diametral pitch	Circular pitch	Divide 3.1416 by the diametral pitch.	$CP = \frac{3.1416}{DP}$
Pitch diameter and number of teeth	Circular pitch	Divide the pitch diameter by the product of 0.3183 and the number of teeth.	$PD = \frac{OD}{0.3183 NT}$
Outside diameter and number of teeth	Circular pitch	Divide the outside diameter by the product of 0.3183 and the number of teeth plus 2.	$CP = \frac{OD}{0.3183 NT + 2}$
Number of teeth and circular pitch	Pitch diameter	The product of the number of teeth, the circular pitch, and 0.3183.	$PD = 0.3183 CP NT$
Number of teeth and outside diameter	Pitch diameter	Divide the product of the number of teeth and the outside diameter by the number of teeth plus 2.	$PD = \frac{NT OD}{NT + 2}$
Outside diameter and circular pitch	Pitch diameter	Subtract from the outside diameter the product of the circular pitch and 0.6366.	$PD = OD - 0.6366 CP$
Addendum and number of teeth	Pitch diameter	Multiply the number of teeth by the addendum.	$PD = NT ADD$
Number of teeth and circular pitch	Outside diameter	The product of the number of teeth plus 2, the circular pitch, and 0.3183.	$OD = (NT + 2) 0.3183 CP$
Pitch diameter and circular pitch	Outside diameter	Add to the pitch diameter the product of the circular pitch and 0.6366.	$OD = PD + 0.6366 CP$
Number of teeth and addendum	Outside diameter	Multiply the addendum by the number of teeth plus 2.	$OD = (NT + 2) ADD$
Pitch diameter and circular pitch	Number of teeth	Divide the product of the pitch diameter and 3.1416 by the circular pitch.	$NT = \frac{3.1416 PD}{CP}$
Circular pitch	Chordal thickness	One-half the circular pitch.	$(t_c) = \frac{CP}{2}$

Having	To Get	Rule	Formula
Circular pitch	Addendum	Multiply the circular pitch by 0.3183.	$ADD = 0.3183 CP$
Circular pitch	Working depth	Multiply the circular pitch by 0.6366.	$WKD = 0.6366 CP$
Circular pitch	Whole depth	Multiply the circular pitch by 0.6866.	$WD = 0.6866 CP$
Circular pitch	Clearance	Multiply the circular pitch by 0.05.	$CL = 0.05 CP$
Circular pitch	Diametral pitch	Divide 3.1416 by the circular pitch.	$DP = \frac{3.1416}{CP}$
Pitch diameter and number of teeth	Diametral pitch	Divide the number of teeth by the pitch diameter.	$DP = \frac{NT}{PD}$
Pitch diameter of gear pinion	Center distance	Add pitch diameter of gear ( $PD_g$ ) to pitch diameter of pinion ( $PD_p$ ) and divide by 2.	$C = \frac{PD_g + PD_p}{2}$
Outside diameter and number of teeth	Diametral pitch	Divide the number of teeth plus 2 by the outside diameter.	$DP = \frac{NT + 2}{OD}$
Number of teeth and diametral pitch	Pitch diameter	Divide the number of teeth by the diametral pitch.	$PD = \frac{NT}{DP}$
Outside diameter and diametral pitch	Pitch diameter	Subtract from the outside diameter the quotient of 2 divided by the diametral pitch.	$PD = OD - \frac{2}{DP}$
Number of teeth and diametral pitch	Outside diameter	Divide the number of teeth plus 2 by the diametral pitch.	$OD = \frac{NT + 2}{DP}$
Pitch diameter and diametral pitch	Outside diameter	Add to the pitch diameter the quotient of 2 divided by the diametral pitch.	$OD = PD + \frac{2}{DP}$
Pitch diameter and number of teeth	Outside diameter	Divide the number of teeth plus 2 by the quotient of the number of teeth divided by pitch diameter.	$OD = NT + 2 + \frac{NT}{PD}$
Pitch diameter and diametral pitch	Number of teeth	Multiply the pitch diameter by the diametral pitch.	$NT = PD DP$

Having	To Get	Rule	Formula
Outside diameter and the diametral pitch	Number of teeth	Multiply the outside diameter by the diametral pitch and subtract 2.	$NT = OD DP - 2$
Diametral pitch	Chordal thickness	Divide 1.5708 by the diametral pitch.	$t_c = \frac{1.5708}{DP}$
Diametral pitch	Addendum	Divide 1 by the diametral pitch.	$ADD = \frac{1}{DP}$
Diametral pitch	Working depth	Divide 2 by the diametral pitch.	$WKD = \frac{2}{DP}$
Diametral pitch	Whole depth	Divide 2.157 by the diametral pitch.	$WD = \frac{2.157}{DP}$
Diametral pitch	Clearance	Divide 0.157 by the diametral pitch.	$CL = \frac{0.157}{DP}$





## APPENDIX IV

# DERIVATION OF FORMULAS FOR DIAMETRAL PITCH SYSTEM

1. TOOTH ELEMENTS based on a No. 1 diametral pitch gear (fig. AIV-1)

a. Addendum (ADD)—.000

(1) The distance from the top of the tooth to the pitch line.

b. Circular Pitch (CP)—3.1416

(1) The length of an arc equal to the circumference of a 1-inch circle, covers one tooth and one space on the pitch circle.

(2) Measure the circular pitch on the pitch line. If you could draw a circle inside the tooth using the 1-inch addendum as the diameter, the circumference of the circle would be 3.1416. Using your imagination, break the circle at one point on the circumference, imagining the circumference is a string. Lay the imaginary string on the pitch line at one side of the tooth. Stretch the other end as far as possible on the pitch line; it will stretch to a corresponding point on the next adjacent tooth on the pitch line.

c. Circular Thickness (CT)—1.5708

(1) One-half of the circular pitch, measured at the pitch line.

d. Clearance (CL)—0.15708

(1) One-tenth of the chordal thickness; move decimal one place to the left.

e. Dedendum (DED)—1.15708

(1) The sum of an addendum plus a clearance.

(2)  $1.000 - \text{ADD}$

$$\frac{0.1570}{-}$$

$$1.1570 - \text{DED}$$

f. Working Depth (WKD)—2.000

(1) The sum of two addendums.

(2)  $1.000 - \text{ADD}$

$$\frac{+1.000}{-} - \text{ADD}$$

$$2.000 - \text{WKD}$$

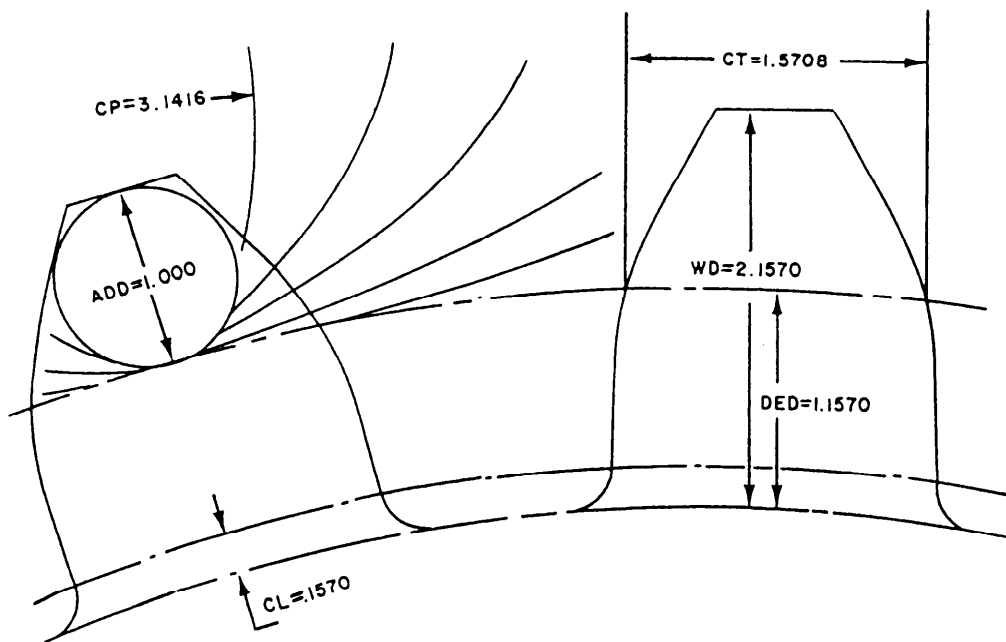


Figure AIV-1.—Tooth elements on a No. 1 diametral pitch gear.

g. Whole Depth (WD)–2.15708

(1) The sum of an addendum and a dedendum.

$$\begin{aligned} (2) & 1.0000 - \text{ADD} \\ & + 1.1570 - \text{DED} \\ & 2.1570 - \text{WD} \end{aligned}$$

h. Diametral Pitch (DP)

(1) The ratio of the number of teeth per inch of pitch diameter.

$$(2) \frac{NT}{PD} = DP$$

i. Chordal Addendum– $a_c$

(1) The distance from the top of a gear tooth to a chord subtending (extending under) the intersections of the tooth thickness arc and the sides of the tooth.

$$(2) a_c = \text{ADD} + \frac{(CT)^2}{4(PD)}$$

j. Chordal Thickness– $t_c$

(1) The thickness of the tooth, measured at the pitch circle.

$$t_c = PD \sin \frac{90^\circ}{N}$$

2. GEAR ELEMENTS

a. Number of Teeth (NT)

(1) Connecting link between the tooth elements and gear elements.

(2) Number of teeth in the gear

$$(3) \frac{PD}{ADD} = NT$$

b. Pitch Diameter (PD)

(1) Diameter of the pitch circle.

(2) For every tooth in the gear there is an addendum on the pitch diameter.

$$(3) ADD \times NT = PD$$

c. Outside Diameter (OD).

(1) The diameter of the gear.

(2) Since there is an addendum on the pitch diameter for each tooth, the two elements are directly related. Therefore, the outside diameter is simply the pitch diameter plus two addendums, or simulated teeth. The formulas read:

$$(a) ADD \times NT = PD$$

$$(b) ADD \times (NT + 2) = OD$$

$$(c) PD + 2ADD = OD$$

d. Linear Pitch (LP)

(1) The linear pitch is the same as the circular pitch except that it is the lineal measurement of pitch on a gear rack

$$(2) CP = LP$$

(3) Figure AIV-2 illustrates linear pitch.

3. GEAR AND TOOTH ELEMENT RELATIONSHIP

<u>TOOTH</u>	<u>GEAR</u>
a. ADD	a. PD
b. DED	b. OD
c. CP	c. $a_c$
d. CT	d. $t_c$
e. WD	
f. CL	
g. DP	

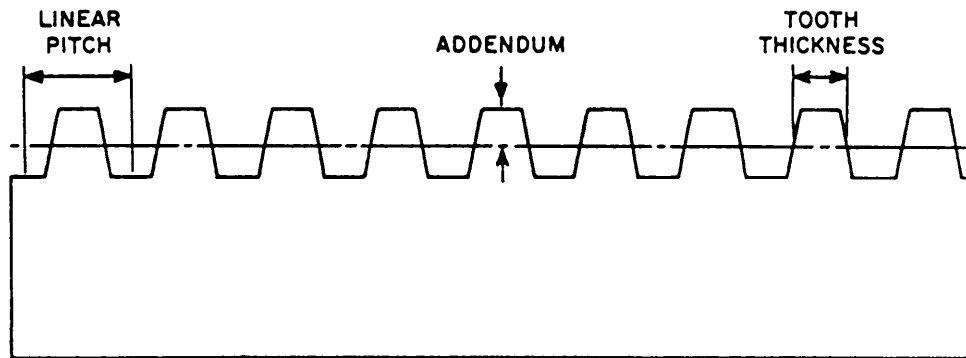


Figure AIV-2.–Linear pitch.

(1) NT is the connecting link between tooth elements and gear elements.

(2) To completely calculate a gear, one tooth and one gear element must be known.

(3) For every tooth in the gear there is a circular pitch on the pitch circle.

(4) For every tooth in the gear there is an addendum on the pitch diameter.

### FORMULAS

$$1. ADD = \frac{1.000}{DP}$$

$$2. CP = \frac{3.1416}{DP}$$

$$3. CT = \frac{1.5708}{DP}$$

$$4. CL = \frac{0.15708}{DP}$$

$$5. DED = \frac{1.15708}{DP}$$

$$6. WKD = \frac{2.000}{DP}$$

$$7. WD = \frac{2.15708}{DP}$$

$$8. DP = \frac{NT}{PD} \text{ or transpose any other formula with DP involved.}$$

$$9. NT = \frac{PD}{ADD}$$

$$10. PD = ADD \times NT$$

$$11. OD = ADD \times (NT + 2)$$



## APPENDIX V

# REFERENCES USED TO DEVELOP THE TRAMAN

### Chapter 1

Kibbe, Richard R., et al., *Machine Tool Practices*, 3d ed., John Wiley and Sons, New York, 1987, Sec. C.

Walker, John R., *Machining Fundamentals*, Goodheart-Wilcox Company, Inc., South Holland, Ill., 1989, Chap. 4.

### Chapter 2

Anderson, James, and Tatro, Earl E., *Shop Theory*, 6th ed., McGraw-Hill Book Company, New York, 1974, Chap. 19.

Kibbe, Richard R., et al., *Machine Tool Practices*, 3d ed., John Wiley and Sons, New York, 1987, Sets. C, E, and F.

McCarthy, Willard J., and Repp, Victor E., Ed.D., *Machine Tool Technology*, Bennett and McKnight, Encino, Calif., 1984, Sec. 3.

Walker, John R., *Machining Fundamentals*, Goodheart-Wilcox Company, Inc., South Holland, Ill., 1989, Chap. 4.

### Chapter 3

Kibbe, Richard R., et al., *Machine Tool Practices*, 3d ed., John Wiley and Sons, New York, 1987, Sec. D.

*Structural Repair*, NAVSEA 59100-AB-GTP-010, Naval Sea Systems Command, Washington, D.C., 1982.

Walker, John R., *Machining Fundamentals*, Goodheart-Wilcox Company, Inc., South Holland, Ill., 1989, Chap. 21.

### Chapter 4

*DoAll Power Saw Instruction Manual*, DoAll Company, Des Plaines, Ill., 1971.

Kibbe, Richard R., et al., *Machine Tool Practices*, 3d ed., John Wiley and Sons, New York, 1987, Sets. G and H.

McCarthy, Willard J., and Repp, Victor E., Ed.D., *Machine Tool Technology*, Bennett and McKnight, Encino, Calif., 1984, Sec. 8.

### Chapter 5

*How to Run a Lathe*, Rev. ed. 56, South Bend Lathe, South Bend, Ind., 1966.

Kibbe, Richard R., et al., *Machine Tool Practices*, 3d ed., John Wiley and Sons, New York, 1987, Sec. F.

Walker, John R., *Machining Fundamentals*, Goodheart-Wilcox Company, Inc., South Holland, Ill., 1989, Chap. 13.

## **Chapter 6**

*How to Run a Lathe*, Rev. ed. 56, South Bend Lathe, South Bend, Ind., 1966.

McCarthy, Willard J., and Repp, Victor E., Ed.D, *Machine Tool Technology*, Bennett and McKnight, Encino, Calif., 1984, Sets. 4 and 9.

Oberg, Erik, et al., *Machinery's Handbook*, 23d ed., Industrial Press Inc., New York, 1988, pp. 1475-1648.

## **Chapter 7**

Kibbe, Richard R., et al., *Machine Tool Practices*, 3d ed., John Wiley and Sons, New York, 1987, Sets. J through L.

Walker, John R., *Machining Fundamentals*, Goodheart-Wilcox Company, Inc., South Holland, Ill., 1989, Chap. 12.

## **Chapter 8**

*Equipment Manual for Lathe, Turret, Vertical*, NAVSEA 0991-LP-125-7010, Naval Sea Systems Command, Washington, D.C. 1968.

Moltrecht, K. H., *Machine Shop Practice*, Vol. 2, Industrial Press Inc., New York, 1981, Chap. 10.

## **Chapter 9**

*Model ITF-V, Operating Instructions*, New Hermes Inc., Decater, Ga.

Moltrecht, K. H., *Machine Shop Practice* Vol. 2, Industrial Press Inc., New York, 1981, Chaps. 1 through 3.

## **Chapter 10**

Kibbe, Richard R., et al., *Machine Tool Practices*, 3d ed., John Wiley and Sons, New York, 1987, Sec. N.

Moltrecht, K. H., *Machine Shop Practice*, Vol. 2, Industrial Press Inc., New York, 1981, Chap. 14.

## **Chapter 11**

Seames, Warren S., *Computer Numerical Control: Concepts and Programming*, 2d ed., Delmar Publishers Inc., Albany, N.Y., 1990.

Thyer, G. E., *Computer Numerical Control of Machine Tools*, 2d ed., Butterworth-Heinemann LID, Oxford, England, 1991.

## **Chapter 12**

*Brush Electroplating on Marine Machinery*, MIL-STD-2197 (SH), Naval Sea Systems Command, Washington, D.C., 1989.

*Process Instruction for Thermal Spray Procedures for Machinery Repair*, 24-1583-Rev. B, Shore Intermediate Maintenance Activity, San Diego, Calif., 1991.

*Thermal Spray Processes for Naval Ship Machinery Applications*, MIL-STD-1687A (SH), Naval Sea Systems Command, Washington, D.C., 1987.

### **Chapter 13**

*Maintenance Manual for Valves, Traps, and Orifices (non-nuclear)*, S9253-AD-MMM-010, Naval Sea Systems Command, Washington, D.C., 1990.

*Technical Manual for Description and Repair of Centrifugal Pumps*, S6225-AP-MMI-0101, Naval Sea Systems Command, Washington, D.C., 1990.

*Vera-Mil Operation and Service Manual*, NAVSEA 0392-LP-072-4000, Naval Sea Systems Command, Washington, D.C., 1985.

### **Chapter 14**

McCarthy, Willard J., and Repp, Victor E., Ed.D., *Machine Tool Technology*, Bennett and McKnight, Encino, Calif., 1984, Sec. 10.

Oberg, Erik, et al., *Machinery's Handbook*, 23d ed., Industrial Press Inc., New York, 1988, pp. 1765-2038.

### **Chapter 15**

*Heat Treatment and Properties of Iron and Steel*, NBS Monograph 88, National Bureau of Standards, Washington, D.C., 1966.

Johnson, Carl G., and Weeks, William R., *Metallurgy*, 5th ed., American Technical Publishers, Inc., Alsip, Ill., 1977.





# INDEX

## A

- Adjustable gauges, 1-7
  - adjustable parallel, 1-14
  - cutter clearance gauge, 1-14
  - dial bore gauge, 1-12
  - dial indicator, 1-9
  - dial vernier caliper, 1-11
  - gear tooth vernier, 1 - 14
  - internal groove gauge, 1- 12
  - micrometers, 1-7
  - surface gauge, 1-16
  - universal bevel, 1-12
  - universal vernier bevel protractor, 1-12
  - vernier caliper, 1-9
  - vernier height gauge, 1-10

## Alloy steels, 3-4

- chromium, 3-4
- molybdenum, 3-4
- nickel, 3-4
- tungsten, 3-4
- vanadium, 3-4

## B

### Bench and pedestal grinders, 5-3

### Bevel gears, 14-14

- milling teeth, 14-20
- nomenclature, 14-16
- selecting cutters, 14-20

## C

### Carbide tool grinder, 5-7

### Care and maintenance of measuring instruments, 1-20

- dials, 1-22
- micrometers, 1-21
- vernier gauges, 1-22

### Cemented carbide, 5-9

- brazed-on tips, 5-9
- grades, 5-10
- insert shapes, 5-11
- insert sizes, 5-12
- operating conditions, 5-9
- toolholder and boring bar styles, 5-12
- toolholder and carbide insert identification, 5-12

### Chip breaker grinder, 5-8

### Computer numerical control, 11-1

- computer-aided design/computer-aided manufacturing, 11-5
- machines, 11-2
- machine safety, 11-1
- numerical control systems, 11-5
- setting the machine origin, 11-9
- tooling, 11-5

### Computer numerical control machines, 11-2

- CNC lathe, 11-3
- CNC vertical spindle milling, 11-3

### Computer numerical control systems, 11-5

- Cartesian coordinate systems, 11-8
- positioning systems, 11-9
- servomechanisms, 11-8
- types of systems, 11-7

### Contact electroplating, 12-7

- applications, 12-9
- electroplating equipment, 12-8
- operator qualification, 12-9
- plating procedures, 12-10
- quality assurance, 12-10

### Continuous feed cutoff saw, 4-11

- band selection and installation, 4-11
- operation, 4-12

Control of tools, 1-4  
    controlled equipage, 1-6  
    methods, 1-4

Copper alloys, 3-4  
    aluminum bronze, 3-5  
    brass, 3-5  
    bronze, 3-5  
    copper-nickel, 3-5  
    gunmetal, 3-5

Cutting tool materials, 5-8  
    cast alloys, 5-8  
    cemented carbide, 5-9  
    ceramic, 5-12  
    high-speed steel, 5-8

Cutting tool terminology, 5-13  
    angle of keenness, 5-14  
    back rake, 5-14  
    end cutting edge, 5-14  
    nose, 5-14  
    side cutting edge, 5-14  
    side rake, 5-14  
    side relief, 5-14

Cylindrical grinder, 10-8  
    operation, 10-9  
    sliding table, 10-8  
    wheelhead, 10-9

## D

Derivation of formulas for diametral pitch system,  
    A-IV

Drilling angular holes, 4-23  
    equipment, 4-23  
    operation, 4-24

Drilling machines and drills, 4-14  
    operations, 4-18  
    radial drill press, 4-16  
    twist drill, 4-17  
    upright drill presses, 4-15

## E

Engine lathe attachments and accessories, 6-11  
    carriage stop, 6-18  
    center rest, 6-6  
    centers, 6-15  
    chucks, 6-13  
    dogs, 6-16  
    follower rest, 6-17  
    grinding attachment, 6-8  
    milling attachment, 6-19  
    taper attachment, 6-17  
    thread dial indicator, 6-18  
    toolholders, 6-12  
    tool post, 6-11  
    tracing attachment, 6-20

Engine lathe components, 6-1

    apron, 6-14  
    bed and ways, 6-6  
    carriage, 6-13  
    compound rest, 6-22  
    feed rod, 6-17  
    headstock, 6-8  
    lead screw, 6-18  
    quick-change gear mechanism, 6-19  
    tailstock, 6-10

Engine lathe operations, 6-33

    boring, 6-38  
    chatter, 6-34  
    coolants, 6-34  
    cutting speeds and feeds, 6-33  
    drilling and reaming, 6-38  
    facing, 6-35  
    knurling, 6-39  
    parting and grooving, 6-37  
    planning the job, 6-33  
    setting up the tool post grinder, 6-40  
    tapers, 6-42  
    turning, 6-35

- Engine lathes, 6-1
  - attachments and accessories, 6-11
  - components, 6-1
  - operations, 6-33
  - other types of engine lathes, 6-20
  - screw threads, 6-46
  - setup, 6-20
- Engine lathe setup, 6-20
  - aligning and leveling, 6-21
  - methods of holding the work, 6-25
  - preparing the centers, 6-23
  - safety, 6-20
  - setting the toolholder and cutting tool, 6-24
- F**
- Filing, 2-18
  - crossfiling, 2-18
  - drawfiling, 2-18
  - using the file card and brush, 2-19
- Fixed gauges, 1-16
  - graduated gauges, 1-16
  - nongraduated gauges, 1-18
- Formulas for spur gearing, A-III
- G**
- Gears and gear cutting, 14-1
  - bevel gears, 14-14
  - helical gears, 14-5
  - materials used for gears, 14-1
  - splines, 14-29
  - sprockets, 14-29
  - spur gears, 14-1
  - stub tooth gears, 14-27
  - worms and worm gears, 14-22
- Glossary, A-I
- Graduated gauges, 1-16
  - acme thread tool gauge, 1-17
  - center gauge, 1-18
  - feeler gauge, 1-18
  - radius gauge, 1-18
  - rules, 1-16
  - scales, 1 - 17
- Grain depth of cut, 10-1
- Grinding handtools, 5-19
- Grinding safety, 5-1
- Grinding speeds, feeds, and coolants, 10-3
  - coolants, 10-4
  - depth of cut, 10-4
  - traverse (work speed), 10-3
  - wheel speed, 10-3
- Grinding wheel balancing, 10-4
- Grinding wheels, 5-2
  - care and storage, 5-7
  - diamond wheels, 5-5
  - installation, 5-5
  - markings and composition, 5-2
  - selection and use, 5-5
  - sizes and shapes, 5-2
  - truing and dressing, 5-6
- Ground single-point, high-speed cutting tools, 5-13
  - cutting tool terminology, 5-13
  - grinding high-speed engine lathe cutting tools, 5-17
  - ground-in chip breakers, 5-15
  - shapes of high-speed engine lathe cutting tools, 5-15
- H**
- Hacksaws, power, 4-4
  - blade selection, 4-6
  - coolant, 4-7
  - feeds and speeds, 4-8
  - operation, 4-10
- Hardness test, 15-28
  - file test, 15-29
  - Rockwell test, 15-28

- Heat-treating equipment, 15-6
  - cooling equipment, 15-10
  - heating equipment, 15-7
- Heat-treating ferrous metals, 15-20
  - alloy tool steels, 15-24
  - annealing, 15-22
  - austempering, 15-22
  - carbon tool steels, 15-23
  - case hardening, 15-23
  - hardening, 15-20
  - martempering, 15-23
  - normalizing, 15-22
  - spheroidizing, 15-22
  - tempering, 15-21
- Heat-treating nonferrous metals, 15-25
- Heat-treating problems, 15-25
  - blistering, 15-28
  - cracking, 15-27
  - design problems, 15-25
  - size changes, 15-27
  - soft spots, 15-27
  - spalling, 15-27
  - warping, 15-27
- Helical gears, 14-5
  - dimensions, real and normal, 14-8
  - gear train ratio, 14-12
  - manufacturing, 14-13
- Honing equipment, 10-20
  - honing hints, 10-21
  - portable equipment, 10-20
  - stationary honing machine, 10-21
  - stone selection, 10-21
- Horizontal boring mill, 8-6
  - combination boring and facing head, 8-7
  - operations, 8-8
  - right-angle milling attachment, 8-8
- Horizontal shaper components, 9-1
  - crossrail assembly, 9-2
  - drive assembly, 9-1
  - main frame assembly, 9-1
  - table feed mechanism, 9-3
  - toolhead assembly, 9-4
- Horizontal shaper operations, 9-5
  - shaping a rectangular block, 9-7
  - shaping angular surfaces, 9-8
  - shaping internal keyways, 9-9
  - shaping irregular surfaces, 9-10
  - shaping keyways in shafts, 9-8
  - speeds and feeds, 9-6
- Horizontal shapers, 9-1
  - components, 9-1
  - operations, 9-5
  - vises and toolholders, 9-4
- Hydraulic and arbor presses, 2-19
- I**
- Identification of metals, 3-11
  - acid test, 3-14
  - spark test, 3-11
- L**
- Layout and benchwork, 2-1
  - filing, 2-18
  - hydraulic and arbor presses, 2-19
  - layout methods, 2-8
  - limits of accuracy, 2-1
  - oxyacetylene equipment, 2-22
  - reading surface finish quality, 2-5
  - scraping and bluing, 2-17
  - screw thread inserts, 2-20
  - surface characteristics of metal, 2-3
- Layout limits of accuracy, 2-1
  - allowance, 2-2
  - tolerance, 2-2

Layout methods, 2-8  
    forming angular lines, 2-9  
    geometric construction of layout lines, 2-13  
    laying out circles and irregular lines, 2-10  
    laying out valve flange boltholes, 2-14  
    lines square or parallel to edges, 2-8  
    using the sine bar, 2-12  
    using the surface plate, 2-11

## M

Measuring instruments, 1-6

    adjustable gauges, 1-7  
    fixed gauges, 1-16

Metal buildup, 12-1

    contact electroplating, 12-7  
    thermal spray systems, 12-1

Metal, designations and markings, 3-6

    ferrous metal designations, 3-6  
    nonferrous metal designations, 3-8  
    standard markings, 3-9

Metallurgy and heat treatment, 15-1

    hardness test, 15-28  
    heat-treating ferrous metals, 15-20  
    heat-treating nonferrous metals, 15-25  
    heat-treating problems, 15-25  
    heat-treating equipment, 15-6  
    principles of heat-treating ferrous alloys, 15-13  
    structure of metal, 15-1

Metals, 3-1

    designations and markings, 3-6  
    identification, 3-11  
    properties, 3-1  
    types, 3-3

Metals and plastics, 3-1

    metals, 3-1  
    plastics, 3-14

Micrometers, 1-7

    ball, 1-8  
    blade, 1-8  
    depth, 1-8  
    groove, 1-8  
    inside, 1-7  
    outside, 1-7  
    thread, 1-8

Milling machine arbors, 7-27

    cutter adapter, 7-29  
    fly cutter, 7-28  
    screw, 7-29  
    screw slotting cutter, 7-28  
    shell end, 7-28  
    spring collet chuck, 7-30  
    standard, 7-27  
    stub, 7-28  
    taper adapter, 7-29

Milling machine attachments, 7-47

    high-speed universal, 7-48  
    rear milling, 7-48  
    universal, 7-47  
    vertical, 7-48

Milling machine components, 7-3

Milling machine cutters, 7-18

    angle, 7-21  
    concave and convex, 7-25  
    corner rounding, 7-25  
    end mill, 7-22  
    face mill, 7-24  
    fly, 7-26  
    gear, 7-25  
    gear hob, 7-26  
    half-side milling, 7-20  
    metal slitting saw, 7-20  
    plain milling, 7-18  
    screw slotting, 7-20  
    side milling, 7-20  
    side milling (interlocking), 7-20  
    sprocket wheel, 7-26  
    T-slot, 7-24  
    woodruff key seat, 7-25

Milling machine cutter selection, 7-26

Milling machine feeds, speeds, and coolants, 7-48

- coolants, 7-52
- feeds, 7-51
- speeds, 7-48

Milling machine indexing, 7-11

- adjusting sector arms, 7-17
- angular, 7-13
- compound, 7-14
- differential, 7-15
- direct, 7-11
- plain, 7-11
- wide-range divider, 7-15

Milling machine operations, 7-30

- angular milling, 7-34
- drilling, reaming, and boring, 7-45
- face milling, 7-32
- fly cutting, 7-45
- plain milling, 7-30
- slotting, parting, and milling keyseats, 7-40

Milling machine workholding devices, 7-7

- circular milling attachment, 7-8
- indexing equipment, 7-8
- right angle plate, 7-7
- toolmaker's knee, 7-7
- vises, 7-7

MR/civilian job descriptions, 1-1

**N**

Nickel alloys, 3-5

- K-monel, 3-5
- nickel-copper, 3-5

Nongraduated gauges, 1-18

- gauge blocks, 1-20
- machinist's square, 1-19
- parallel blocks, 1-19
- ring and plug gauges, 1-20
- sine bar, 1-19
- straightedges, 1-18
- thread and measuring wires, 1-20

Numerical control systems, 11-5

**O**

Oxyacetylene equipment, 2-22

- adjusting the flame, 2-24
- backfire and flashback, 2-26
- extinguishing the flame, 2-25
- safety, 2-25
- setting up, 2-24

**P**

Pantographs, 9-14

- attachments, 9-20
- cutter speeds, 9-17
- engraving a dial face, 9-22
- engraving a graduated collar, 9-22
- grinding cutters, 9-17
- major components, 9-16
- setting copy, 9-16
- setting the pantagraph, 9-16
- using a circular copy plate, 9-22

Plain-carbon steel, 3-3

- high-carbon steel, 3-4
- low-carbon steel, 3-4
- medium-carbon steel, 3-4

Planer operations, 9-13

- feeds, 9-13
- holding the work, 9-14
- rail elevation, 9-13
- table speeds, 9-13

Planers, 9-11

- major components, 9-12
- operations, 9-13

Plastics, 3-14

- characteristics, 3-15
- lathe operations, 3-18
- machining operations, 3-15
- major groups, 3-15

- Stub tooth gears, 14-27
  - American standard system, 14-27
  - Fellows stub-tooth gear system, 14-27
  - method of manufacture, 14-28
- Surface characteristics of metal, 2-3
- Surface grinder, 10-5
  - cross traverse table, 10-5
  - operation, 10-7
  - sliding table, 10-6
  - wheelhead, 10-6
  - workholding devices, 10-6
- T**
- Thermal spray systems, 12-1
  - applications, 12-1
  - applying the coating, 12-6
  - preparing surfaces, 12-4
  - qualification of personnel, 12-2
  - quality assurance, 12-7
  - surface finishing, 12-6
  - types of thermal spray, 12-2
- Thermal spray; preparing surfaces, 12-4
  - cleaning, 12-4
  - surface roughening, 12-5
  - undercutting, 12-5
- Tool and cutter grinder, 10-10
  - cutter sharpening, 10-11
  - cutter sharpening setups, 10-14
- Toolrooms and tools, 1-1
  - care and maintenance of measuring instruments, 1-20
  - control, 1-4
  - inspection, 1-4
  - measuring instruments, 1-6
  - organization, 1-2
  - safety, 1-2
- U**
- Upright drill presses, 4-37
  - general-purpose drill press (round column), 4-38
  - heavy-duty drill press (box column), 4-39
  - sensitive drill press, 4-16
- V**
- Vertical shapers, 9-11
- Vertical turret lathe, 8-1
  - taper turning, 8-4
  - tooling, 8-3
- W**
- Worms and worm gears, 14-22
  - center-to-center distance, 14-25
  - cutting teeth on a milling machine, 14-26
  - formula development, 14-23
  - hobs, 14-25
  - selecting a cutter, 14-24
  - worm and worm wheel nomenclature, 14-23



- Power saws, 4-1
  - continuous feed cutoff saw, 4-3
  - hacksaw, 4-1
  - metal-cutting bandsaw, 4-4
- Precision grinding machines, 10-1
  - cylindrical grinder, 10-8
  - grain depth of cut, 10-1
  - honing equipment, 10-20
  - speeds, feeds, and coolants, 10-3
  - surface grinder, 10-5
  - tool and cutter grinder, 10-10
  - wheel balancing, 10-4
- Principles of heat-treating ferrous alloys, 15-13
  - effects of heating, holding, and cooling, 15-16
  - equilibrium diagrams, 15-13
  - iron-carbon phase diagram, 15-14
  - transformation temperatures, 15-13
- R**
- Reading surface finish quality, 2-5
  - interference microscope inspection, 2-6
  - profilometer, 2-6
  - surface analyzer, 2-8
  - touch comparison, 2-6
  - visual inspection, 2-5
- References used to develop the TRAMAN, A-V
- Repair job preparation, 13-1
  - calibration, 13-1
  - planned maintenance system, 13-2
  - planning work, 13-2
  - quality assurance, 13-1
- Repair jobs, 13-2
  - broken bolts and studs, 13-15
  - broken taps, 13-17
  - in-place machining, 13-19
  - pumps, 13-13
  - shafts, 13-2
  - valves, 13-4
- Repair work, 13-1
  - job preparation, 13-1
  - repair jobs, 13-2
- S**
- Scope of MR rating, 1-1
- Scraping and bluing, 2-17
- Screw thread inserts, 2-20
- Screw threads, 6-46
  - classes of threads, 6-52
  - cutting on a lathe, 6-54
  - left-hand screw threads, 6-58
  - measuring threads, 6-52
  - multiple screw threads, 6-58
  - other forms of threads, 6-50
  - threads on tapered work, 6-60
  - V-form threads, 6-48
- Shaper and planer tools, 5-18
- Shapers, 9-1
  - horizontal shapers, 9-1
  - vertical shapers, 9-11
- Sharpening twist drills, 5-21
  - sharpening to drill brass, 5-23
  - thinning the web, 5-23
- Sprockets, 14-29
  - classes, 14-30
  - manufacture, 14-30
  - material, 14-30
- Spur gears, 14-1
  - diametral pitch system, 14-3
  - machining, 14-5
  - terminology, 14-2
- Structure of metal, 15-1
  - allotropy, 15-5
  - crystals and grains, 15-2
  - internal structure, 15-5
  - space lattices, 15-2



