

# INTERNAL GRINDER

FOR 9", 10-K, 10",  
13", 14½", 16", 16/24" AND 17"

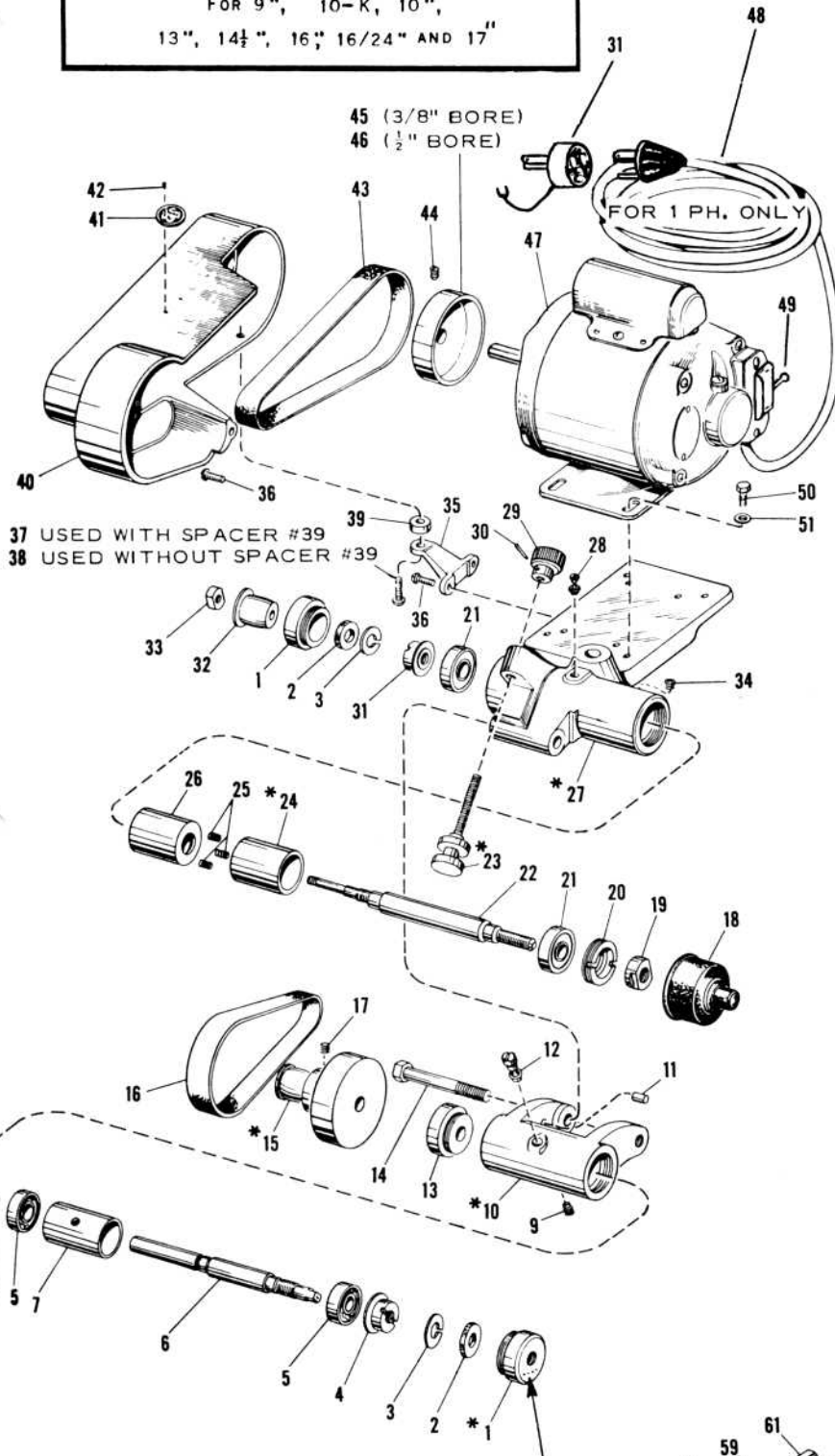

37 USED WITH SPACER #39  
38 USED WITHOUT SPACER #39

45 (3/8" BORE)  
46 (½" BORE)

UNIT CODE NUMBER  
STAMPED HERE

ITEM NO.	PART NAME	PART NO.
1	RETAINER CAP (2-3)	*AS2411NH1
2	FELT	PT2421NH1
3	SPLIT WASHER	PT2422NH1
4	RETAINER NUT	PT2410NH1
5	BALL BEARING	PT2450NH1
6	JACKSHAFT SPINDLE	PT2430NH2
7	JACKSHAFT SPACER	PT2424NH1
8	RETAINING RING	PT2444NH1
9	SET SCREW	121 X 5
10	JACKSHAFT HOUSING (9-11-12)	*AS2429NH2
11	STRAIGHT PIN	PT1825-1
12	OILER	PT2679-1
13	RETAINER CAP	PT2443NH1
14	CAP SCREW	115 X 248
15	JACKSHAFT PULLEY (17)	*AS2419NH2
16	BELT	PT2438NH1
17	SET SCREW	120 X 903
18	SPINDLE NOSE PROTECTOR	PT2449NH1
19	RETAINER NUT	PT2406NH1
20	RETAINER SEAL	PT2407NH1
21	BEARING	PT2437NH1
22	SPINDLE	PT2401NH1
23	BELT ADJ. SCREW (29-30)	*AS2432NH1
24	SPACER - FRONT (25)	*AS2408NH1
25	COIL SPRING	162 X 54
26	SPACER - REAR	PT2409NH1
27	FRAME (28-34)	*AS2400NH2
28	OILER	PT2679-1
29	BELT TIGHTNER ADJ. KNOB	PT2433NH1
30	PIN	160 X 25
31	Adapter	PT6883
32	SPINDLE PULLEY	PT2412NH1
33	LOCK NUT	PT2415NH1
34	SET SCREW	121 X 5
35	BRACKET	PT2470NH1
36	SCREW	101 X 308
37	SCREW	101 X 312
38	SCREW	101 X 308
39	SPACER	PT2471NH1
40	BELT GUARD (41-42)	*AS2431NH1
41	INSIGNIA PLATE	PT3300
42	DRIVE SCREW	130 X 100
43	BELT	PT2439NH1
44	SCREW	122 X 505
45	MOTOR PULLEY	*AS2472NH1
46	MOTOR PULLEY (44)	*AS2414NH1
47	MOTOR - SPECIFY	
48	CORD SET (FOR 1 PH. ONLY)	PT1104-2
49	SWITCH (FOR 1 PH. ONLY)	SE4679
50	CAP SCREW	112 X 8
51	WASHER	PT1679-1
52	END WRENCH	PT2458-2
53	CHUCK (54)	*AS2403NH2
54	CHUCK NUT	PT2402NH2
55	ARBOR (56-57)	*AS2425NH1
56	WASHER	PT2442NH1
57	NUT	138 X 24
58	ARBOR (56-57)	*AS2426NH1
59	ARBOR (57-60)	*AS2427NH1
60	WASHER	PT2404NH1
61	ARBOR (57-60)	*AS2428NH1
62	GRINDING WHEEL	CE2925
63	GRINDING WHEEL	CE2926

\*AVAILABLE ONLY AS SUB-ASSEMBLY. PARTS INCLUDED ARE INDICATED BY THE ITEM NUMBERS APPEARING IN PARENTHESIS AFTER PART NAME.

SERIAL NUMBER OF LATHE AND UNIT CODE NUMBER "MUST" ACCOMPANY ORDER.

## CLAMP BOLT ASSEMBLY

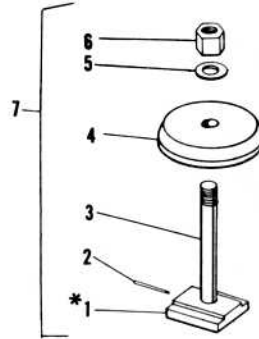

ITEM NO.	PART NAME	9" AND 10K	10"	13"	14 1/2"	16" & 16/24"	17"
		PART NO.	PART NO.	PART NO.	PART NO.	PART NO.	PART NO.
1	CLAMP (2-3)	*AS1577NK1	*AS1577R1	*AS1577T1	*AS1577F1	*AS1577H1	*AS1577H1
2	PIN	160 X 19	160 X 19	160 X 19	160 X 21	160 X 21	160 X 21
3	CLAMP STUD	PT1585NR1	PT1585NR1	PT1585T1	PT1585F1	PT1585H1	PT1585H1
4	RAISING BLOCK	-----	-----	PT1586T1	PT1586F1	PT1586H1	PT1586GJ1
5	WASHER	161 X 22	161 X 22	161 X 22	161 X 22	161 X 22	161 X 22
6	CLAMPING NUT	PT283NK1	PT283NK1	PT283NK1	PT283NK1	PT283NK1	PT283NK1
7	CLAMP BOLT EQUIPMENT (1-4-5-6)	CE307NK	CE307R	CE307T	CE307F	CE307H	CE307GJ

## INSTRUCTION

The South Bend internal grinder attachment mounts on the compound rest top. Adjust the belt to proper tension with belt adjusting screw item 23. The grinder spindle and the jackshaft spindle run on high speed ball bearings which require no adjustment.

## LUBRICATION - GRINDER

Remove oil screws periodically, items 12 and 18, and add a few drops of spindle bearing oil at both points. Use SBL CE1600 oil or equal.

## LUBRICATION - MOTOR (1 PHASE)

Motors having ball bearings are packed with grease sufficient for about two years of normal service. At the end of that time, the bearings should be cleaned thoroughly of the old grease and repacked about one-third full with General Electric ball-bearing grease.